



Kangaroo
Hoppers



15FT Round
Kids Trampoline
Installation Guide

Video
Tutorial

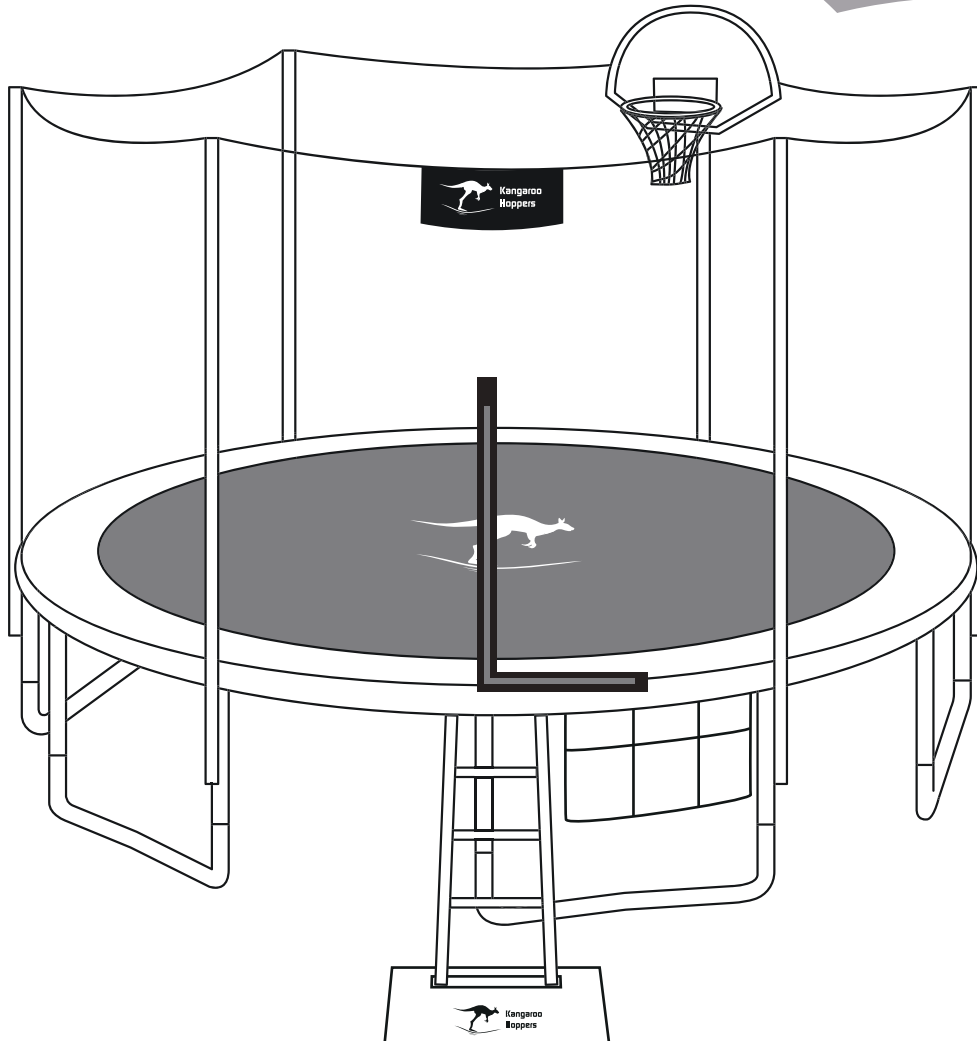

15FT Round Kids Trampoline

⚠️ WARNING

- THE MAXIMUM WEIGHT OF THE USER SHALL NOT EXCEED 375 LBS (170 KG).
- NOT RECOMMENDED FOR CHILDREN UNDER 6 YEARS OF AGE.
- PROPERLY STORE THE PRODUCT AWAY DURING HEAVY WINDS.
- SAVE THIS MANUAL FOR FUTURE REFERENCE.

***NOTICE:** Read these materials prior to assembling and using this trampoline with trampoline enclosure, and make sure that you have mature knowledgeable supervision.

RECEIVING BOXES IN DETAIL

PRIOR TO ASSEMBLY:

Please note that all accessories will be divided into **THREE BOXES** for delivery. Please confirm that you have received the following **THREE BOXES** before installation, and confirm that all the accessories in each box are not missing.

Box A					
NO.	Part	Q' ty	NO.	Part	Q' ty
2	Vertical Tube A	6 pcs	6	Ladder	1 pc
7	Safety Net	1 pc	9	Lower Support Pole	6 pcs
17	T-Socket	12 pcs	18	Gloves	2 pcs

Box B					
NO.	Part	Q' ty	NO.	Part	Q' ty
1	Frame Rail	5 pcs	8	Foam Pad	1 pc
11	Upper Support Pole	6 pcs			

Box C					
NO.	Part	Q' ty	NO.	Part	Q' ty
1	Frame Rail	7 pcs	3	Leg Tube	6 pcs
4	Vertical Tube B	6 pcs	5	Jumping Mat	1 pc
10	Spring	108 pcs	15	Basketball Hoop Set	1 pc
19	Ladder Mat	1 pc	20	Shoes Storage Bag	1 pc
	Screw Set	1 pc		Manual	1 pc

*Please note, the numbers of the Part Identification Chart will be used in the installation process. If any parts are missing, please immediately contact us at support@kangaroojumpers.com.

TABLE OF CONTENTS

Prefaces:

Introduction	1
Kindly Reminder	1

Precautions :

User Instructions and Rules	2
Weather Conditions	3
Trampoline Location	4

Trampoline Assembly Instructions:

Part List for 15 Feet Trampoline	5
Step 1 - Trampoline Frame Assembly	6
Step 2 - Trampoline Mat Assembly	7
Step 3 - Trampoline Poles Assembly	8
Step 4 - Trampoline Pad And Net Assembly	9
Step 5 - Trampoline Ladder Assembly	10
Step 6 - Basketball Hoop Assembly	11
Step 7 - Trampoline Hoop Assembly	12
How to Inspect the Trampoline for Safe Use	14

PREFACES

⚠ WARNING READ THESE MATERIALS PRIOR TO ASSEMBLING AND USING THIS TRAMPOLINE. FAILURE TO DO SO CAN RESULT IN SERIOUS INJURY OR DEATH.

INTRODUCTION:

Thank you for purchasing a Kangaroo Hoppers product! Your Kangaroo Hoppers Trampoline is made of quality materials to provide you and your family with many years of enjoyment and exercise. Enjoy your Kangaroo Hoppers Trampoline! Our website: kangarohoppers.com.

It is very important that the owners and users of this trampoline have adequate knowledge of techniques and rules for safe use. Restrict access to any unauthorized users without your consent. Children must be supervised at all times by a knowledgeable and mature adult while using the trampoline. Take precautions to prevent access to the trampoline by children when there is no adult supervision.

Please also ensure proper placement of this product to avoid injuries. The best surface to place your product is over flat dirt or grass, with no obstructions beneath or around the product. The product must not be used in windy conditions as wind can cause unexpected movement of the product. The product must be properly stored away or disassembled completely during severe windy conditions.

If you have questions after reading this manual, please email us at support@kangarohoppers.com for customer care. The trained customer service will provide immediate assistance within 24 hours.

KINDLY REMINDER:

The owner and supervisors of the trampoline are responsible to make all users aware of practices specified in the Use Instructions. The trampoline enclosure is only to be used as an enclosure for a trampoline of a size for which the enclosure is designed.

All trampolines require maintenance at some point. Springs may need to be replaced, rail pieces may become bent, stitching in the mat and frame pads may rot out. Proper care and maintenance help to prolong the life of the trampoline and reduce the possibility of injury.



DO NOT attempt or allow somersaults. This will increase your chances of landing on your head or neck and can cause serious injuries, such as paralysis or death.



NOT RECOMMEND children under 6 years of age.
DO NOT use if you are over 375 lbs (170 kg).

Use trampoline and trampoline enclosure only with mature, knowledgeable supervision.



DO NOT attempt to jump over the barrier.



DO NOT intentionally rebound off the barrier.
DO NOT hang from, kick, cut or climb on the barrier.



DO NOT dunk with the basketball hoop.
DO NOT hand on the rim.

PREFACES

NOTE: Read all instructions in this manual carefully before assembling or using this product. Keep this manual in a safe place for future reference.

- Do not attempt or allow somersaults. Landing on the head or neck can cause serious injury, paralysis, or death, even when landing in the middle of the bed.
- Do not use the trampoline as a springboard to other objects. Avoid bouncing when tired. Keep turns short.
- Do not attempt to jump over the barrier. Do not attempt to crawl under the barrier. Do not intentionally rebound off the barrier. Do not hang from, kick, cut, or climb on the barrier.
- Climb on and off the trampoline. It is a dangerous practice to jump from the trampoline to the floor or ground when dismounting or to jump onto the trampoline when mounting.
- Flex knees as feet come in contact with trampoline bed to stop bounce. Learn it before attempting others.
- Always start your jump at the center of trampoline mat.
- While keeping the head upright, focus your eyes around the trampoline to help control the bounce.
- Learn fundamental bounces and body positions thoroughly before trying more advanced skills. A variety of trampoline activities can be carried out by performing the basic fundamentals in various series and combinations, performing one fundamental after another, with or without feet bounces between them.
- Avoid bouncing too high. Stay low until bounce control and repeated landing in the center of the trampoline can be accomplished. Control is more important than height.
- Keep objects away which could interfere with the performer. Maintain a clear area around the trampoline.
- Wear clothing free of drawstrings, hooks, loops, or anything that could get caught in the barrier.
- Do not allow more than one person on the trampoline. Use by more than one person at the same time can result in serious injuries.
- Trampolines over 20 inches (51 cm) tall are not recommended for use by children under 6 years of age.
- Do not use the trampoline while under the influence of alcohol or drugs.
- If a trampoline ladder is used, the supervisor should remove it from the trampoline when leaving the area to prevent unsupervised access by children under 6 years of age.
- For additional information concerning the trampoline equipment, contact the manufacturer.
- For information concerning skill training, contact a certified trampoline instructor.

PRECAUTIONS:

A trampoline can become airborne when exposed to sustained wind or gusting wind conditions, which result in serious injury, paralysis, or death, and property damage. To reduce risks, disassemble trampoline and enclosure, store them until weather conditions improve. Anchoring a trampoline frame may prevent the trampoline from moving as a result of the wind, but even anchored trampolines can become airborne or damaged. Consult a qualified contractor to determine what type of anchor works best in your location.

WEATHER CONDITIONS:

1. Cold Weather Protection

The Kangaroo Hoppers Trampoline System is designed for year-round outdoor use. However, in climates of cold weather where snow and ice are common, we recommend the trampoline mat, springs, frame pad, and net be removed and stored in a dry area out of the sun. To remove these parts, simply complete the instructions for installing them in reverse order.



2. Ice and Snow

Left unattended in snow and ice, your trampoline mat will accumulate weight in the middle, causing damage to your springs. This type of damage is not covered by warranty. Use extreme care in removing any ice and snow that may have accumulated on the mat before removing the mat for storage. Do not use a sharp object - such as a shovel, hoe, or garden rake - to remove ice or snow as this may damage the mat. This type of damage is not covered by warranty. We suggest using a high-pressure water hose and spraying upward from underneath the trampoline, starting at the mats lowest point. Another option is to pour hot water on the ice and snow to melt it away.

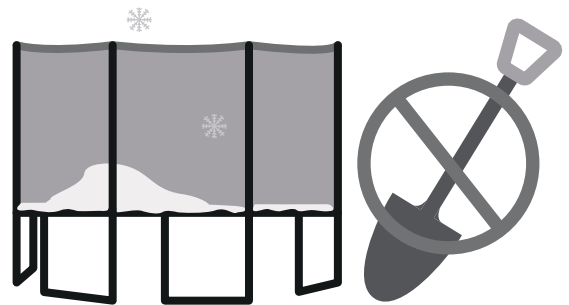

3. Windy Conditions

It is possible for the trampoline to be blown about by a high wind. If you live in an area where there are winds strong enough to move the product, you may use a Kangaroo Hoppers Trampoline Anchor Kit to tie down your trampoline (The diagram shows the Kangaroo Hoppers Trampoline Anchor Kit). If you anticipate severe winds, the trampoline should be moved to a sheltered location or completely disassembled.

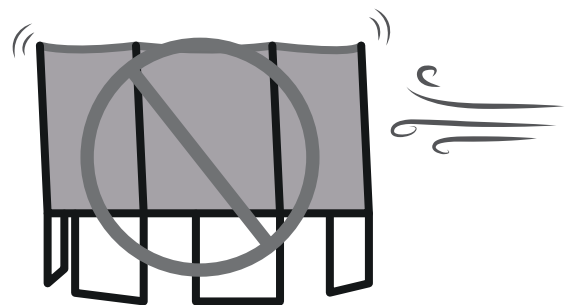

TRAMPOLINE LOCATION:

1. Place the trampoline on a flat surface. Make sure that the trampoline is stable so that the wind or jumps do not cause any displacement on the surface.
2. Maintain a clearance of at least 6 meters (20 feet) directly above the trampoline to prevent accidental collisions, e.g. with tree branches that can cause injury.
3. Maintain at least 3 meters (10 feet) of free space around the trampoline. There should be no objects in this area that could cause injury if someone falls off the trampoline. Place the trampoline away from walls, fences, and buildings.
4. Remove all objects under the trampoline before use.

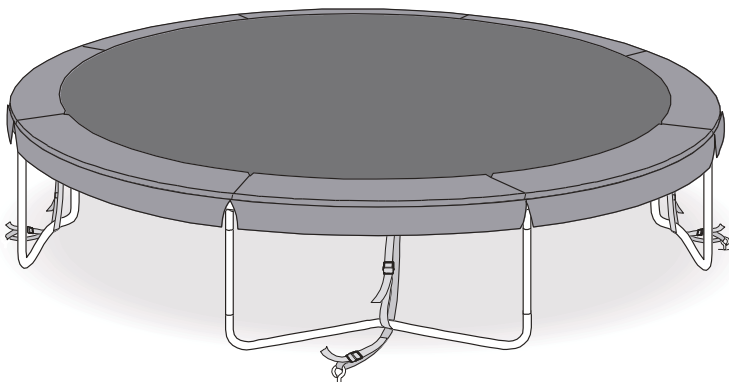
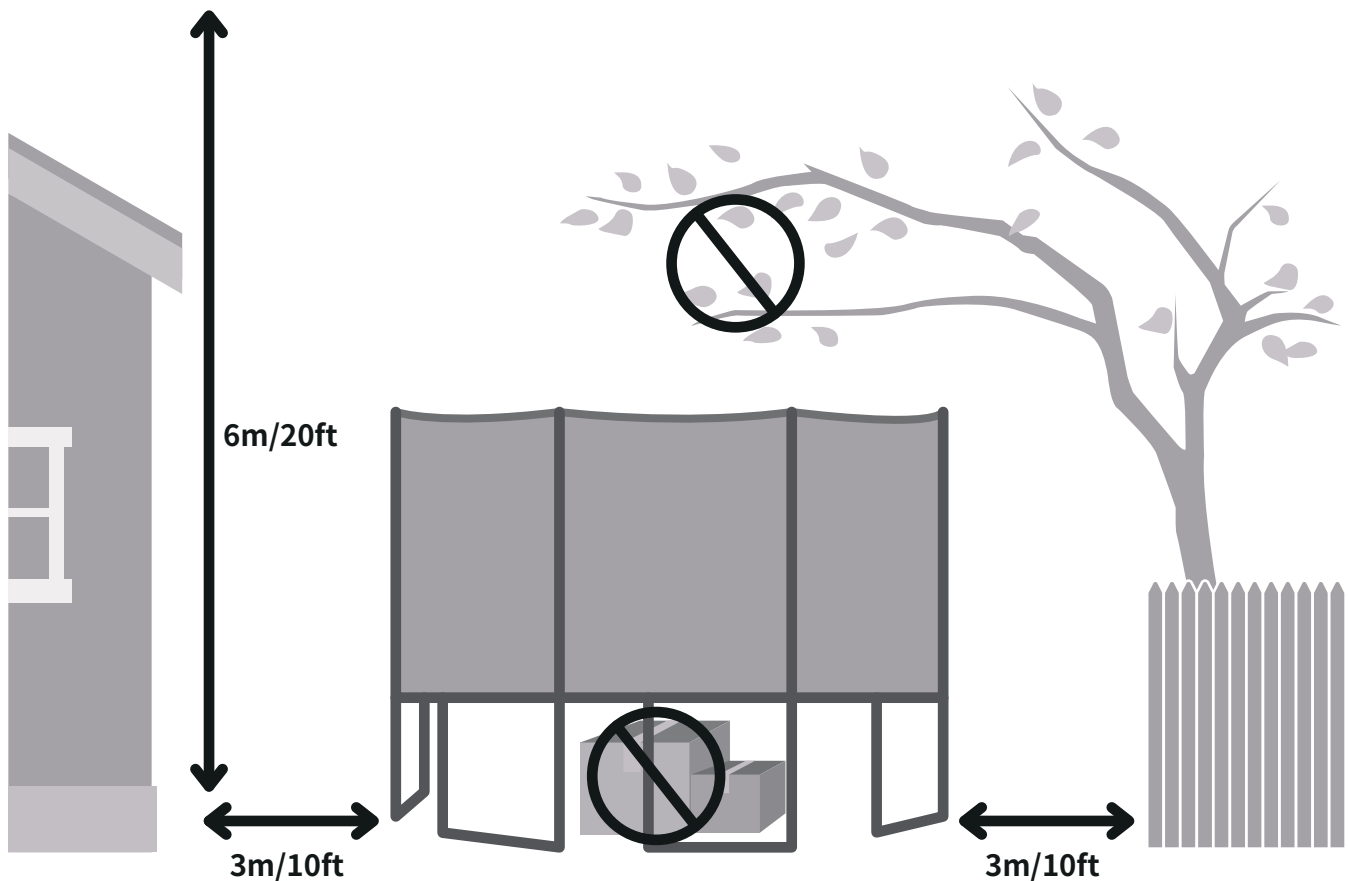

NOTE: You can use a Kangaroo Hoppers Trampoline Anchor Kit to tie down your trampoline. The anchor kit can be found in our Accessories Section on Amazon or official website.











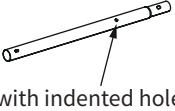

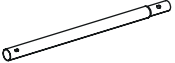

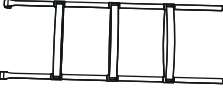
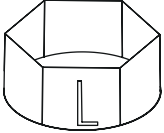
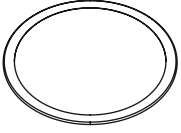
ASSEMBLY AND ADJUSTMENT

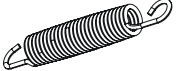
TWO PEOPLE ARE NEEDED TO ASSEMBLE THE TRAMPOLINE AND ENCLOSURE. ALWAYS WEAR GOGGLES AND GLOVES.

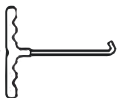
BEFORE YOU BEGIN:

Review all steps before beginning assembly and read all precautions before using it. Before you begin assembling your Kangaroo Hoppers Trampoline, make sure the trampoline and trampoline enclosure is in a proper location. If you are missing any parts, please email us at support@kangaroojumpers.com.

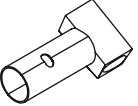
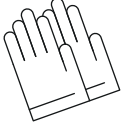
PARTS LIST

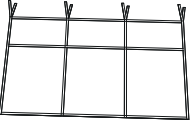
NO.	Part SKU	Q'ty	Diagram	NO.	Part SKU	Q'ty	Diagram
1	Frame Rail 101401000206002	12 pcs		2	Vertical Tube A 101401000205002	6 pcs	 with indented hole
3	Leg Tube 101401000207005	6 pcs		4	Vertical Tube B 101401000207006	6 pcs	
5	Jumping Mat 20205000090	1 pc		6	Ladder (Including Tool Set) 101401000205003	1 set	
7	Safety Net 20205000286	1 pc		8	Foam Pad 20205000296	1 pc	
9	Lower Support Pole 101401000205001	6 pcs		10	Spring 20409001156	108 pcs	
11	Upper Support Pole 101401000206001	6 pcs		12	T-Hook 30301001790	2 pcs	
13	Long Screw Set 30101000888	12 pcs		14	L-Wrench 30101000620	1 pc	
15	Basketball Hoop Set 101401000207004	1 box		16	Support Plug 20204000908	12 pcs	
17	T-Socket 101401000205004	12 pcs		18	Gloves 30401000008	2 pair	
19	Ladder Mat 20219000398	1 pc		20	Shoes Storage Bag 20219000395	1 pc	

ASSEMBLY AND ADJUSTMENT

STEP 1 TRAMPOLINE FRAME ASSEMBLY (Two People Are Required)

NO.	Part	Q'ty	NO.	Part	Q'ty
1	Frame Rail	12 pcs	2	Vertical Tube A	6 pcs
3	Leg Tube	6 pcs	4	Vertical Tube B	6 pcs
17	T-Socket	12 pcs			

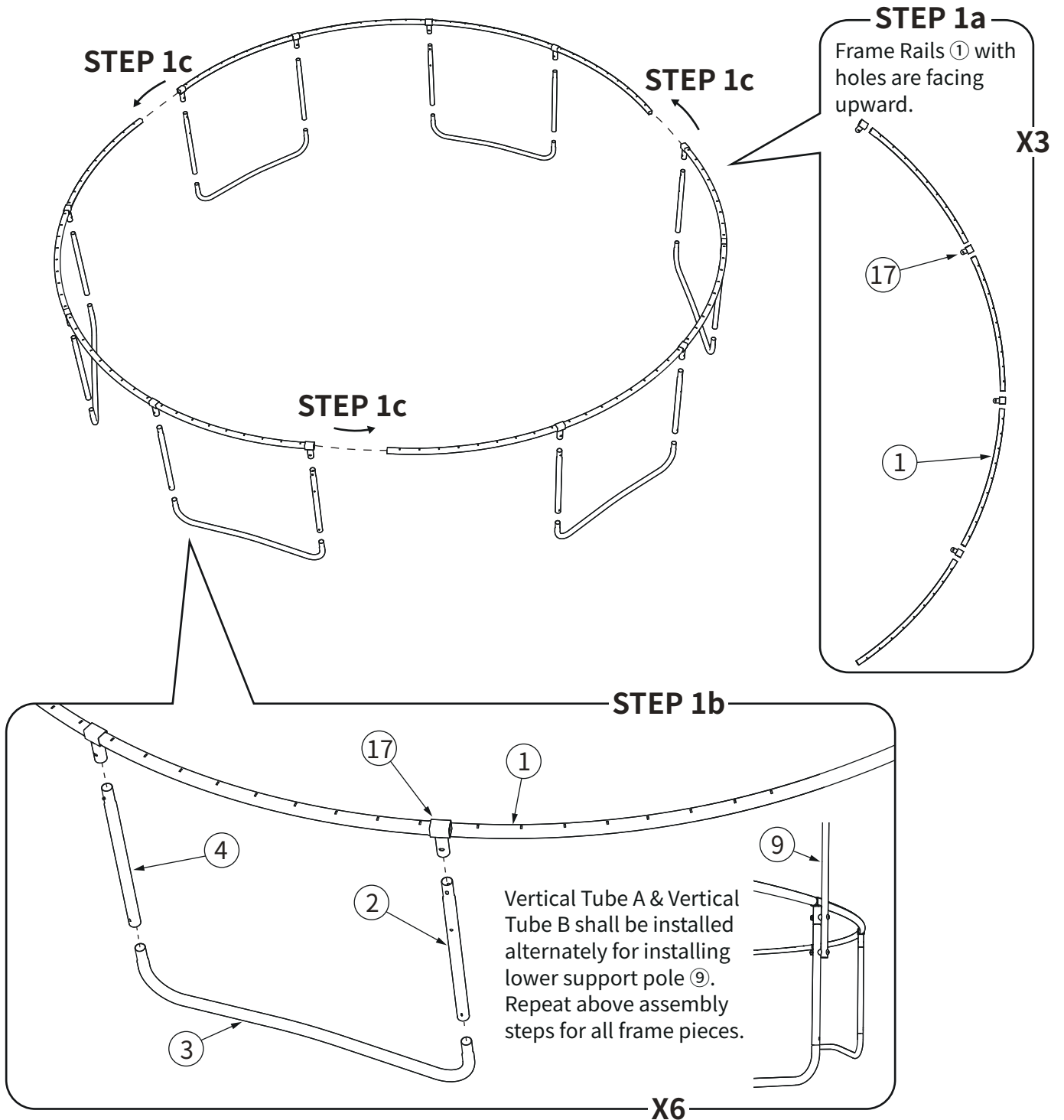

ASSEMBLY AND ADJUSTMENT

STEP 2 TRAMPOLINE MAT ASSEMBLY (Two People Are Required)

NO.	Part	Q'ty	NO.	Part	Q'ty
5	Jumping Mat	1 pc	10	Spring	108 pcs
12	T-Hook	2 pcs			

Note: Use the T-hook (12) to pull spring out from the mat.

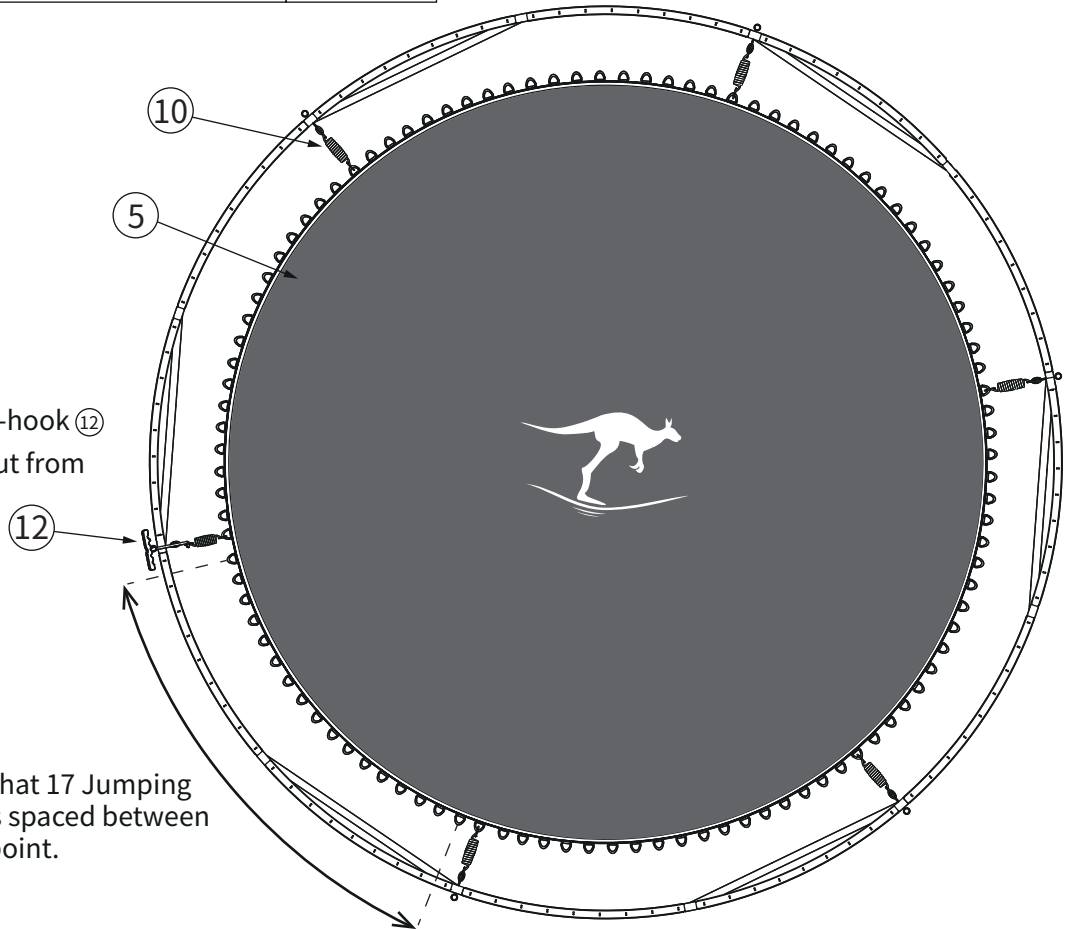

Make sure that 17 Jumping Mat V-Rings spaced between each start point.

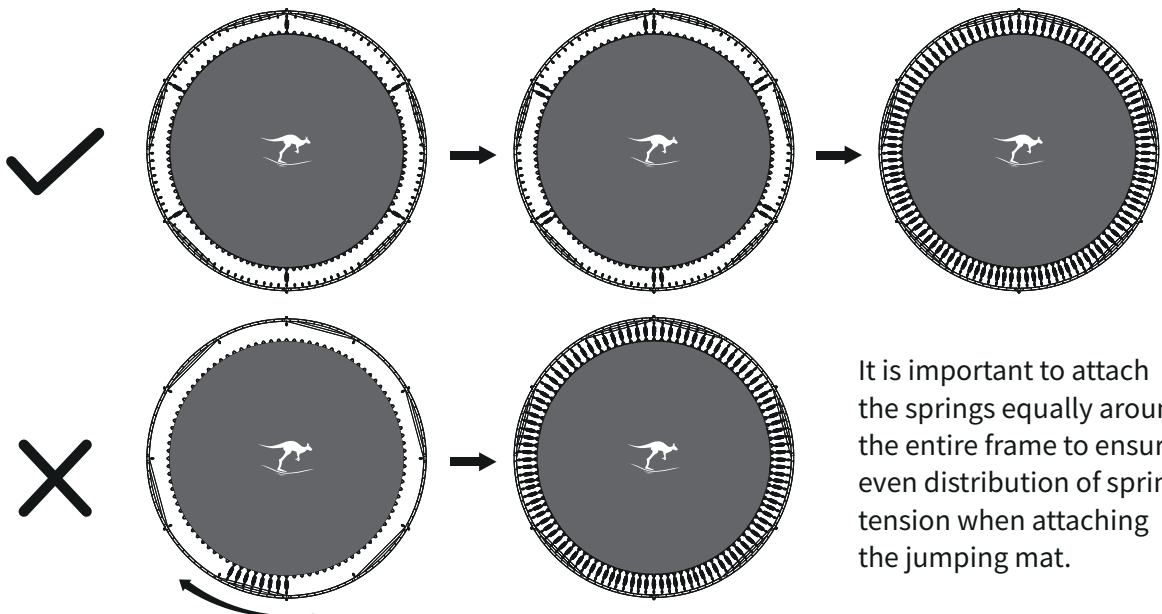

It is important to attach the springs equally around the entire frame to ensure even distribution of spring tension when attaching the jumping mat.

ASSEMBLY AND ADJUSTMENT

STEP 3 TRAMPOLINE POLES ASSEMBLY (Two People Are Required)

NO.	Part	Q'ty	NO.	Part	Q'ty
7	Safety Net	1 pc	9	Lower Support Pole	6 pcs
11	Upper Support Pole	6 pcs	13	Long Screw Set	12 pcs
16	Support Plug	12 pcs			

STEP 3b

Insert the Upper Support Pole ⑪ Safety Net ⑦ one by one.

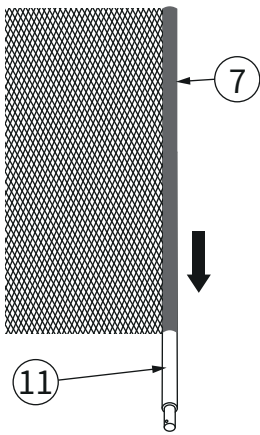

*All the support poles are covered with the blue foam.

X6

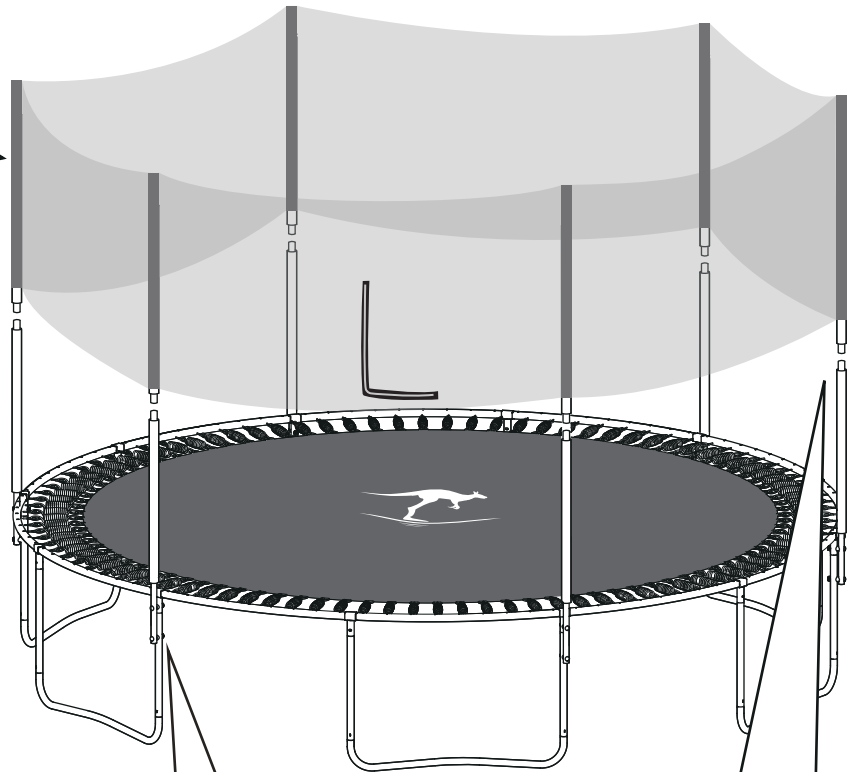

STEP 3a

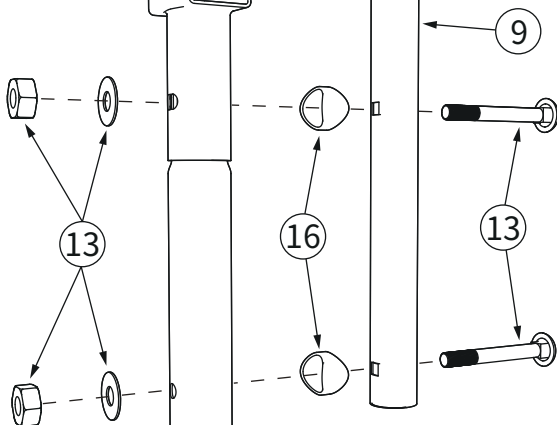

X6

STEP 3c

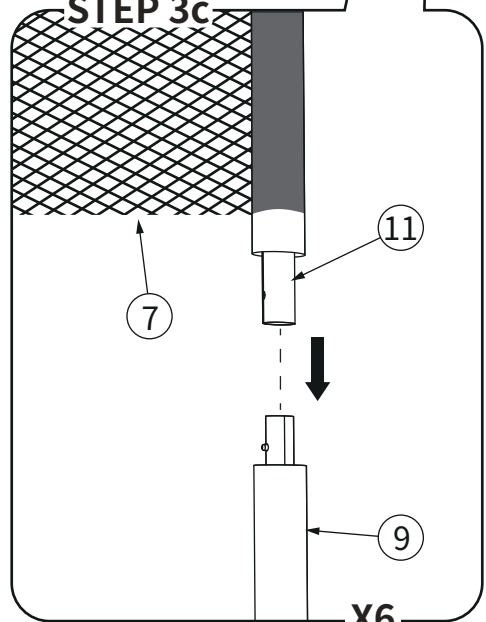

X6

ASSEMBLY AND ADJUSTMENT

STEP 4 TRAMPOLINE PAD AND NET ASSEMBLY (Two People Are Required)

NO.	Part	Q'ty
8	Foam Pad	1 pc

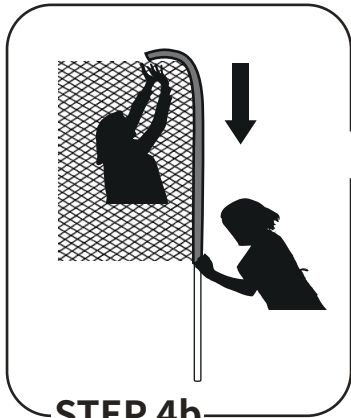

STEP 4b

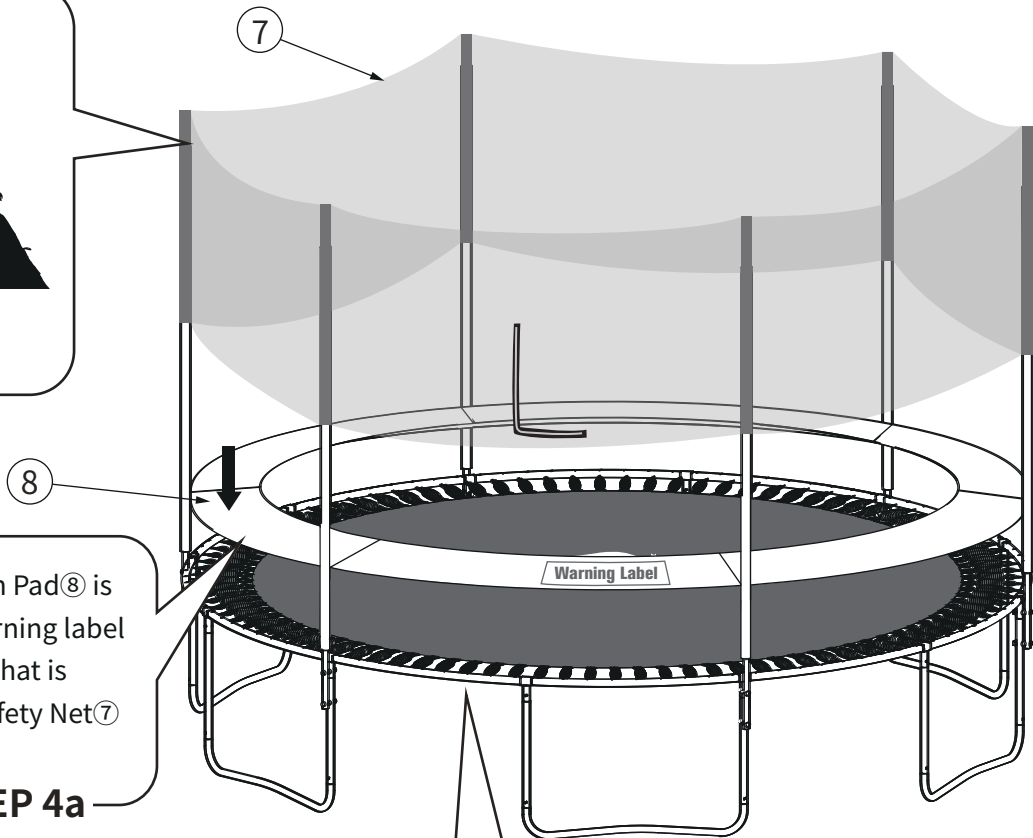

Make sure the Foam Pad[®] 8 is placed with the warning label beside a leg frame that is aligned with the Safety Net[®] 7 entrance.

STEP 4a

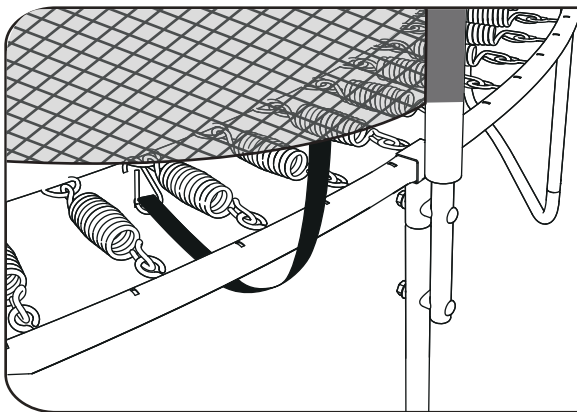





Locate the plastic straps which are sewn to the underside of the Foam Pad[®] 8, and connect the Foam Pad[®] 8 to the main frame by tying it.

STEP 4c

ASSEMBLY AND ADJUSTMENT

STEP 5 TRAMPOLINE LADDER ASSEMBLY



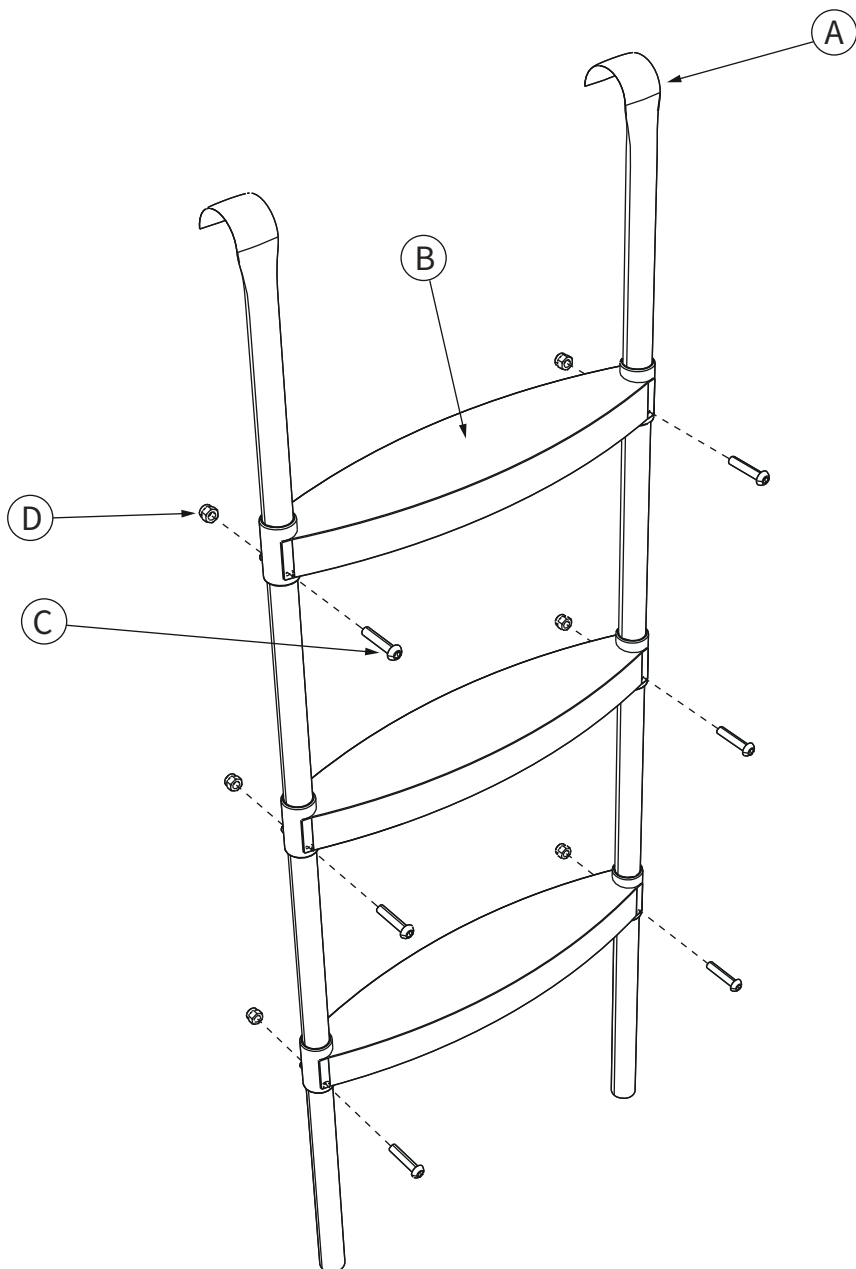

NO.	Part	Q'ty	Diagram
A	Supports	2 pcs	
C	M6 Bolt	6 pcs	
E	Allen Key	1 pc	



NO.	Part	Q'ty	Diagram
B	Ladder Spreader	3 pcs	
D	M6 Nut	6 pcs	



ASSEMBLY AND ADJUSTMENT

STEP 6 BASKETBALL HOOP ASSEMBLY



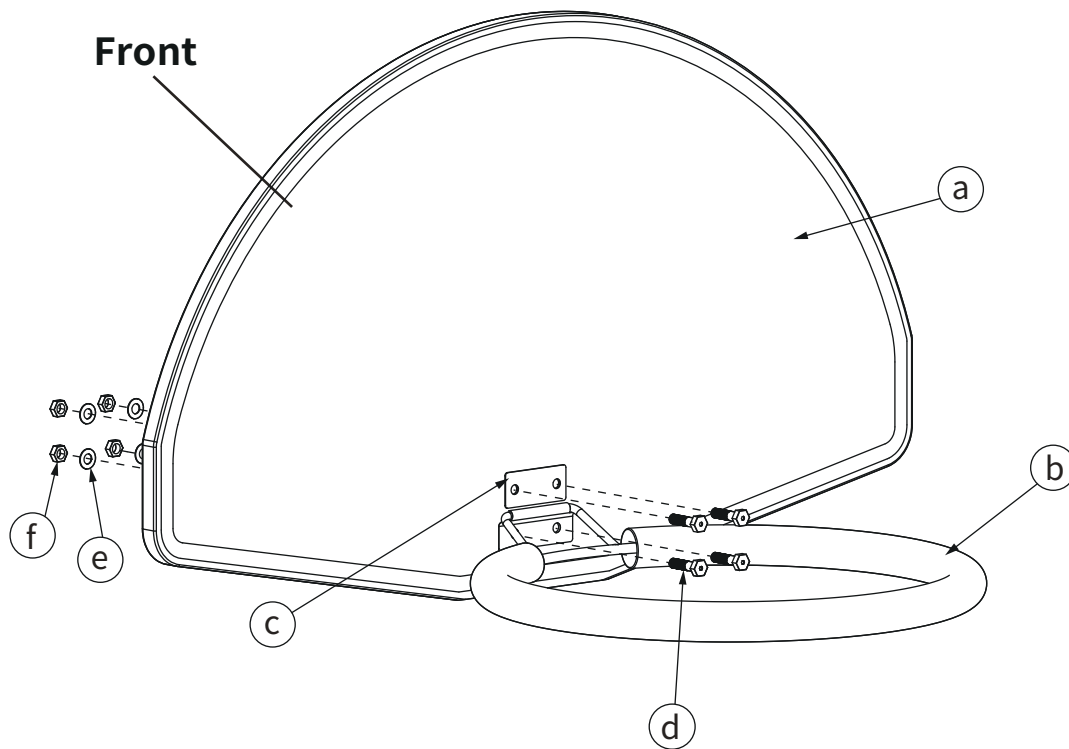

NO.	Part	Q'ty	Diagram
a	Backboard	1 pc	
c	Connection Plate	1 pc	
e	M6 Washer	4 pcs	
g	M6 Wrench	2 pcs	



NO.	Part	Q'ty	Diagram
b	Ring	1 pc	
d	M6 Bolt	4 pcs	
f	M6 Nut	4 pcs	



ASSEMBLY AND ADJUSTMENT

STEP 7 TRAMPOLINE HOOP ASSEMBLY (Two People Are Required)

NO.	Part	Q'ty	Diagram
h	Net	1 pc	
j	Bracket	2 pcs	
l	M8 Washer	4 pcs	
n	M8 Wrench	1 pc	

NO.	Part	Q'ty	Diagram
i	Flat Plate	1 pc	
k	M8 Bolt	4 pcs	
m	M8 Nut	4 pcs	

After assembling the basketball hoop, connect it to the trampoline pole. Because of the structure of the top rod, use a pair of scissors to cut small holes in the net webbing at points A, B, C & D as shown (this should not affect the integrity of your net). Hole A and B should be approximately 2 inches (5 cm) below the top of your net (or at the desired height). The distance between A & B and C & D should be 3.2 inches (8 cm) and between A & C and B & D 2.4 inches (6 cm).

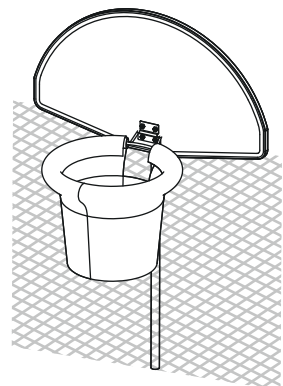
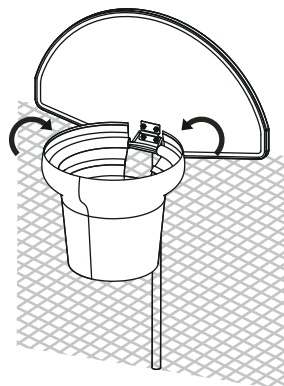
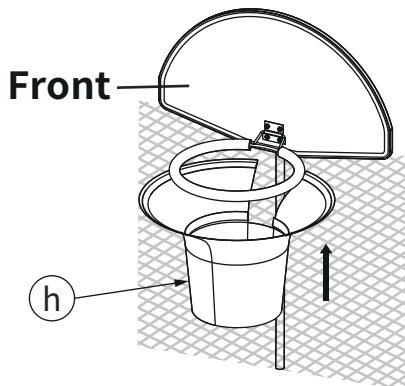
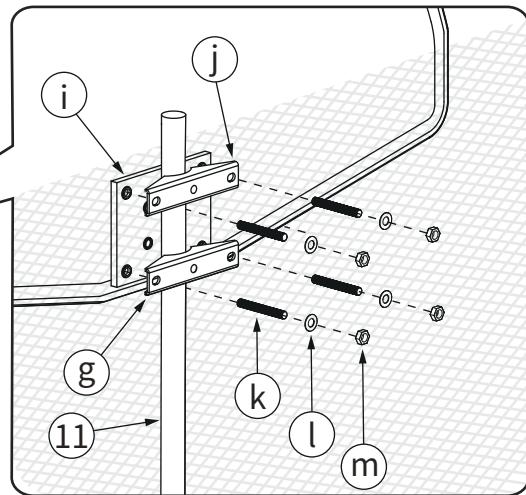
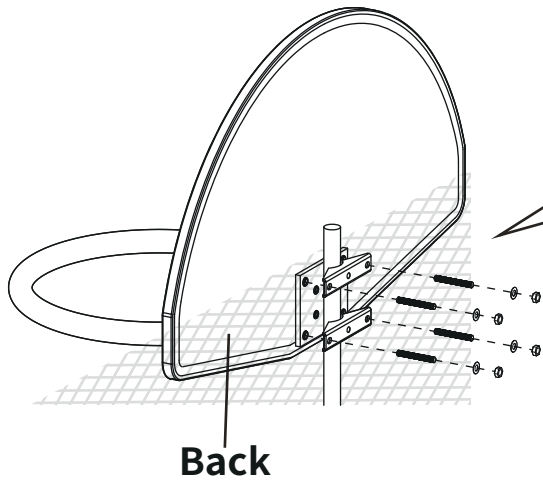
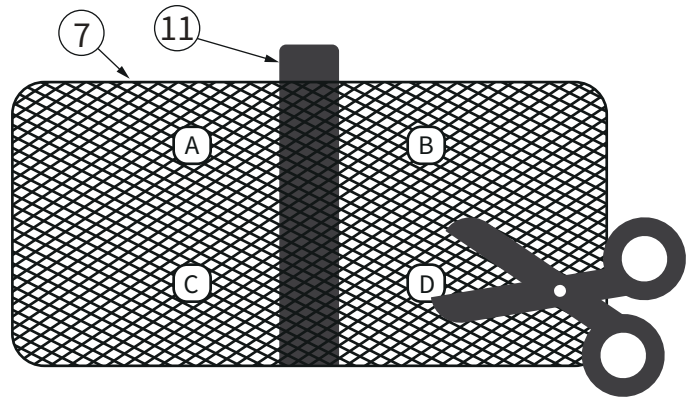

Congratulations!

You have made your own trampoline! Remember to read the next page carefully, then you can have fun with your families!

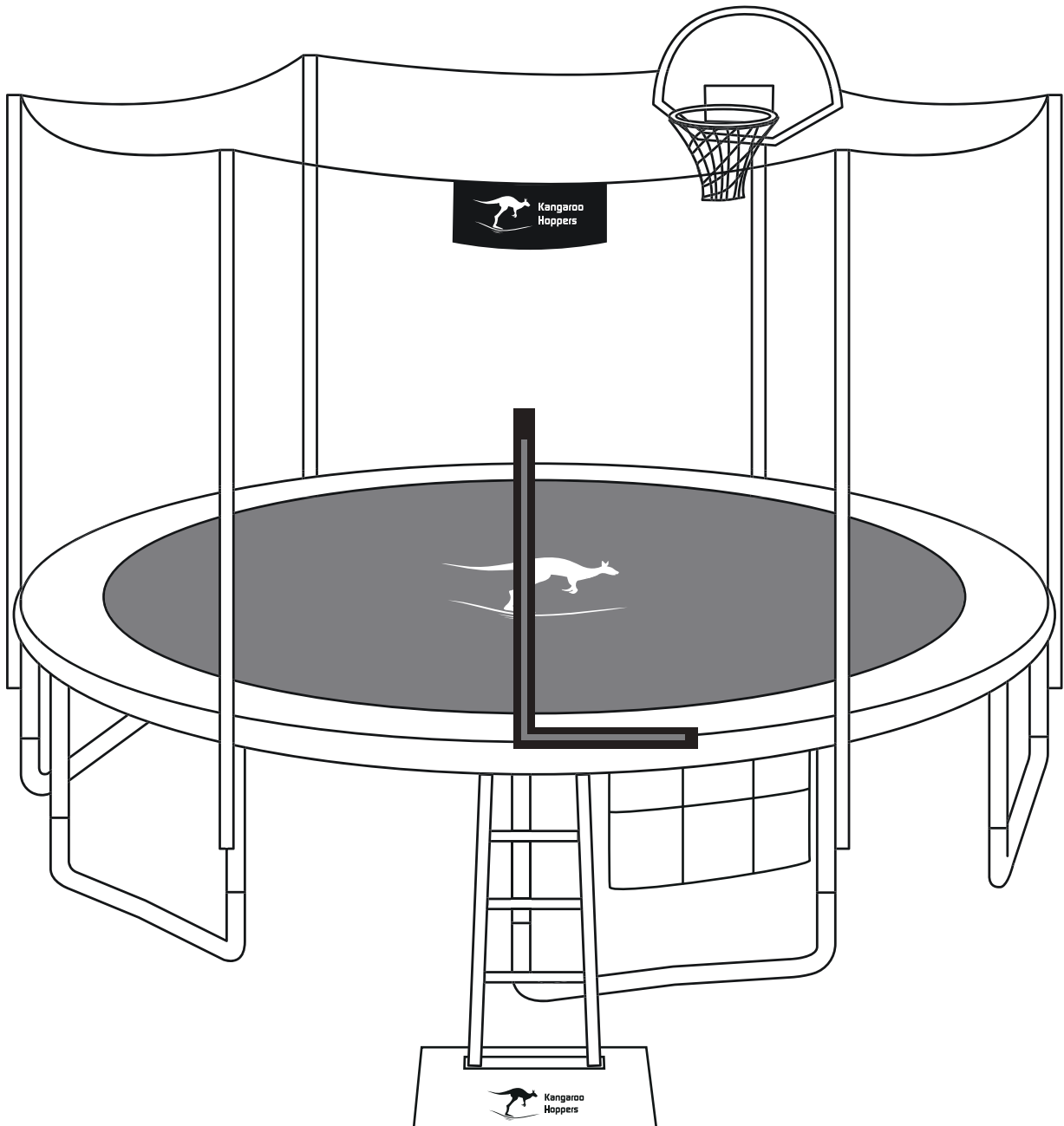

HOW TO INSPECT THE TRAMPOLINE FOR SAFE USE

1. Inspection on Trampoline

Inspect the trampoline before each use and replace any worn, defective, or missing parts. The following conditions could represent potential hazards:

- Missing, improperly positioned, or insecurely attached frame padding.
- Puncture, frays, tears, or holes worn in the bed or frame padding.
- Deterioration in the stitching or fabric of the bed or frame padding.
- Ruptured springs.
- A bent or broken frame.
- A sagging bed.
- Sharp protrusions on the frame or suspension system.

2. Inspection on Safety Enclosure

Inspect the trampoline enclosure before each use and replace any worn, defective, or missing parts. The following conditions could represent potential hazards:

- Missing, improperly positioned, or insecurely attached barrier or enclosure support system (frame) padding and pole caps.
- Puncture, frays, tears, or holes worn in the barrier or support system (frame) padding.
- Deterioration in the stitching or fabric of the barrier or support system (frame) padding.
- Bent or broken support system (frame).
- A sagging barrier.
- Sharp protrusions on the support system (frame) or suspension system.

3. Inspection on Trampoline Mat

Periodically inspect the trampoline for worn out or rotten stitching around the trampoline mat (bed). Stitching may fail due to excessive use or exposure to extreme weather. In most cases, evidence of deterioration will make itself known in the form of:

- Broken stitching around the edge of the mat.
- Rotten or frayed fabric at the v-ring straps.

NOTE: The “bed” mentioned above and elsewhere in this manual, refers to the jumping surface (generally referred to as the “mat”). The “frame” mentioned refers to the rail assembly pieces of the trampoline.

CAUTION: If any deterioration is found, all bouncing must cease and the trampoline must be disassembled or otherwise protected against use until the condition is remedied. The mat should be replaced with the appropriate Kangaroo Hoppers part. Remember, the only thing between the jumper and the ground is the mat. If a deteriorated mat is not inspected properly, further jumping could cause the mat to pull away from the straps in a large area and the jumper may land on the ground, which could cause serious injury.

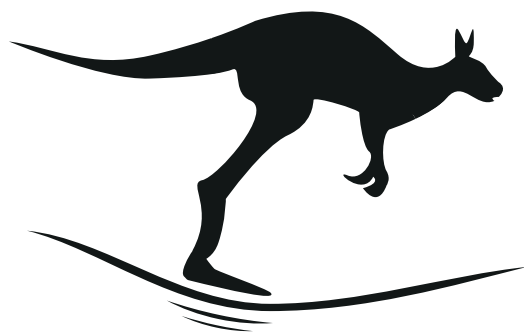

Kangaroo Hoppers



Kangaroo Hoppers



kangaroojumpers.official



Kangaroo jumpers



www.kangaroojumpers.com