



SHOCKSTOP PRO ENDURANCE SUSPENSION SEATPOST

Thanks for choosing the Redshift Sports ShockStop Suspension Seatpost!

The seatpost provides tunable suspension to increase comfort and performance during your ride. This seatpost is different than other seatposts, so please read these instructions and warnings completely before installing or using the seatpost.

Check out instructional videos and additional resources at www.redshiftsports.com/fa



If you are unfamiliar with bike maintenance or seatpost installation, or if you lack the required tools, please visit your local bike shop or contact Redshift Sports customer service for assistance (support@redshiftsports.com). Improper installation or use may void the product's warranty.

COMPATIBILITY:

This seatpost is designed for bicycle frames with a circular seat tube. It is important to check that your seat tube matches the diameter of your seatpost. The seatpost may be used with larger diameter seat tubes by using the correct diameter seatpost shim. In order to reduce stresses on the post and frame, only use seatpost shims of at least 100 mm (4 in.) in length. Using the seatpost in a different diameter seat tube without an appropriate shim may cause damage or failure of the seatpost or bicycle frame.

PARTS IDENTIFICATION:

#	QTY	PART NAME
1	1	Seatpost & Linkage
2	1	Lower Saddle Clamp
3	1	Upper Saddle Clamp
4	2	Saddle Clamp Nuts
5	2	Saddle Clamp Bolts
6	1	Fender
7	1	Preload Adjustment Plug
8	1	Spring Spacer*
9	1	Softest Elastomer
10	1	Inner Coil Spring (Optional)
11	1	Outer Coil Spring
12	1	Firmest Elastomer

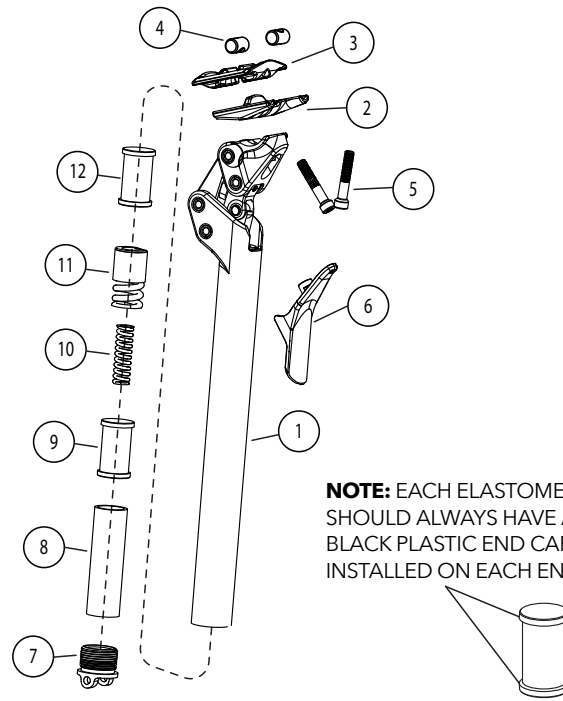

NOTE: EACH ELASTOMER SHOULD ALWAYS HAVE A BLACK PLASTIC END CAP INSTALLED ON EACH END

*350mm seatpost length shown. 280mm seatpost does not have the spacer.

ADJUSTING PRELOAD:

The Shockstop seatpost is fully adjustable to fit you and your riding preference. Different elastomers can be used to make large adjustments to the stiffness, and then fine-tuning can be accomplished by adjusting the preload plug located at the bottom of the seatpost.

A preload adjustment of at least "1" is the softest setting. Turning the preload plug further into the seatpost will increase the stiffness and firm up the suspension. This can be done by hand, or if necessary, a 4mm hex wrench can be inserted through the side holes in the plug to provide additional leverage. The firmest setting is with the preload plug turned all the way in (it does not need to be tight).

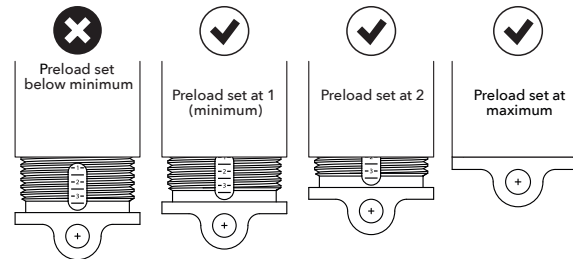

WARNING! DO NOT SET THE PRELOAD ADJUSTMENT BELOW THE "1" MARK. DOING SO CAN CAUSE INTERNAL PARTS TO LOOSEN OR FALL OUT WHILE RIDING.

As a starting point, make sure the spring stack is configured correctly based on your weight or preference (refer to the table below), and dial the preload to a minimum of the "2.5" position. Adjust the preload as needed from this starting point. Even a half turn of the preload plug can make a noticeable difference in ride feel, so make small adjustments to find your preferred setting.

NOTE:

- You may need to **increase** the preload slightly after the first few rides as the spring stack "settles in".
- If there is any "play" or "free movement" at the top of the suspension travel, you may need to adjust the preload past "1" before the spring stack is fully engaged.

SETUP RECOMMENDATIONS:

The ShockStop PRO Endurance comes preinstalled with a red (medium) elastomer, inner coil and outer coil, and a green (soft) elastomer. An additional red (medium) elastomer is included in the package. The chart shown below is a good starting point, but different riders may prefer stiffer or softer settings than the chart recommends. Riding position and terrain can also dramatically affect the required preload setting, so don't be afraid to experiment with different settings to find your best ride!

RIDER WEIGHT	TOP POSITION	MIDDLE POSITION	BOTTOM POSITION
<135 lb <61 kg	Red	Outer Coil Spring	Green
135-175 lb 61-79 kg	Red	Outer + Inner Coil Spring	Green
<175-242 lb <79-110 kg	Red	Outer + Inner Coil Spring	Red

242 lb (110 kg) is the max rider weight. Additional configurations possible. See www.redshiftsports.com for full details.

CHANGING ELASTOMERS:

NOTE: THE SPRING STACK ORDER IS IMPORTANT. THE FIRMEST ELASTOMER MUST BE INSTALLED IN THE TOP POSITION, THE COIL SPRING(S) IN THE MIDDLE POSITION, AND THE SOFTEST ELASTOMER AT THE BOTTOM.

WARNING! FAILURE TO INSTALL THE COIL SPRING(S) IN THE MIDDLE POSITION WILL RESULT IN MALFUNCTION OR DAMAGE TO THE SEATPOST.

SPRING STACK ORDER

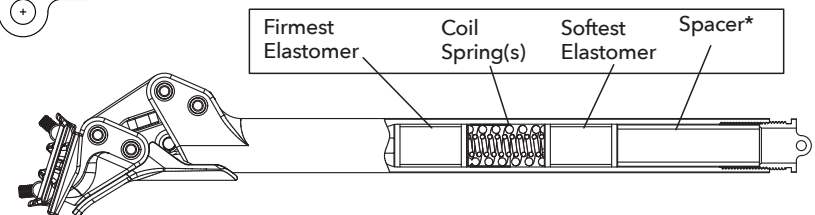

*350 mm seatpost length shown. 280mm seatpost does not have the spacer.

CHANGING ELASTOMERS:

1. Remove seatpost from frame.
2. Turn the seatpost upside-down and completely unscrew the preload plug. This can be done by hand or by inserting a 4 mm hex wrench through the side holes in the plug to provide additional leverage.
3. Tilt seatpost to slide internal components out of the bottom of the seatpost.

NOTE: THE TOP ELASTOMER MAY NOT FALL OUT ON ITS OWN. IF YOU NEED TO REMOVE IT, YOU CAN TAP THE END OF THE SEATPOST ON A WOODEN SURFACE, OR USE A RUBBER Mallet TO DISLodge IF NEEDED.

4. Turn the seatpost upside-down and move the suspension linkages to the "topped out" position.
5. Reinstall the internal components, noting the order shown in figure "Spring Stack Order". The protective material around the outer spring should be oriented towards the top of the seatpost. If the inner coil is installed, make sure it seats inside the outer coil. When fully installed, the spacer (350mm length) or lower elastomer endcap (280mm length) should sit a few millimeters inset from the bottom of the seatpost.
6. Seat the linkage against the bushing as shown below.

⚠ WARNING! MAKER SURE THE LINKAGE IS PROPERLY SEATED AGAINST THE BUSHING BEFORE PROCEEDING TO STEP 7.

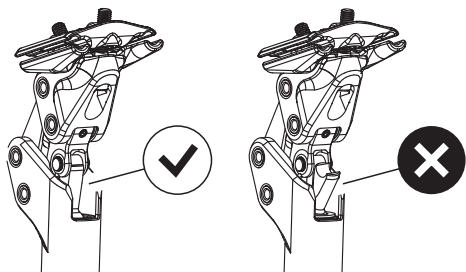

7. Re-install preload plug and adjust as-needed for desired suspension firmness.

WARRANTY

We stand behind the products we sell and want you to have an amazing experience with your Redshift components. Warranty details and return instructions for all Redshift products can be found at www.redshiftsports.com/warranty.

INSTALLING THE SEATPOST

⚠ STOP! THE SHOCKSTOP SEATPOST MUST BE SET UP WITH THE APPROPRIATE PRELOAD ADJUSTMENT AND/OR SPRING COMBINATION BEFORE INSTALLING. SEE "SETUP RECOMMENDATION" AND "SETTING PRELOAD" SECTIONS FIRST!

1. Prior to removing your existing post, you may wish to measure and record the existing height, fore-aft position, and tilt angle of your saddle for future reference.
2. Remove your existing seatpost and saddle. Clean the inside of the bicycle's seat tube and ensure that the inside of the seat tube is free of burrs and sharp edges. Apply a thin layer of grease to the inside of the seat tube. DO NOT grease seat tubes of carbon frames unless specified by the frame manufacturer.
3. Insert the seatpost into your bicycle seat tube to the approximate desired height. Do not twist the seatpost during insertion. Ensure that the seatpost is inserted far enough into the seat tube that the minimum insertion line on the seatpost is not visible above the frame's seatpost clamp.
4. Tighten the bicycle's seatpost clamp bolt according to the bicycle manufacturer's torque specification.
5. Use a 4 mm hex wrench to loosen the saddle clamp bolts until the threads are barely engaged in the nuts. Install the saddle between the upper and lower clamp. Some saddle rail shapes may require the bolts to be fully unthreaded from the nuts to install the saddle.

NOTE: POSITION LOWER CLAMP WITH LONGER RAIL SUPPORTS TOWARD THE BACK OF THE SADDLE

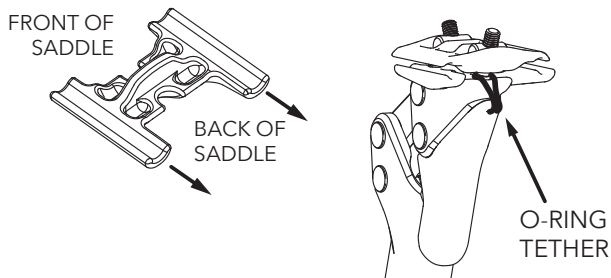

6. If installing the seatpost fender, completely remove rear saddle clamp bolt from the nut, loop fender o-ring around bolt under the upper saddle clamp, and reinstall bolt as shown in the picture.
7. Use a 4 mm hex wrench to lightly tighten the front and rear clamp bolts to hold the saddle in place. Make sure that the hex wrench is inserted completely into the hex hole in the bolt heads to avoid damaging or stripping the bolt.
8. Position the saddle in the desired fore-aft position within the saddle clamp.
9. Use a 4 mm hex wrench to adjust the saddle angle by tightening or loosening the front or rear saddle clamp bolts. Once the desired saddle angle is achieved, alternately tighten both bolts in quarter turn increments, using a torque wrench for the front bolt and a standard hex wrench for the rear bolt. Stop tightening both bolts once the front bolt reaches 6 N-m of torque. Do not exceed 9 Nm.

⚠ WARNING! ADJUSTING THE SADDLE CLAMP TILT BEYOND ITS RANGE MAY DAMAGE THE SEATPOST: WHEN TIGHTENING THE REAR BOLT TILTING REARWARD, THE UPPER SADDLE CLAMP MUST NOT BE IN CONTACT WITH THE REAR PORTION OF THE LINKAGE MECHANISM. WHEN TIGHTENING THE FRONT BOLT TILTING FORWARD, THERE MUST BE A GAP OF AT LEAST 2 MM BETWEEN THE UPPER SADDLE CLAMP AND THE UPPER LINKAGE.

⚠ WARNING! DO NOT OVER TIGHTEN SADDLE CLAMP BOLTS! OVERTIGHTENING MAY LEAD TO SEATPOST FAILURE, POTENTIALLY CAUSING SERIOUS INJURY OR DEATH. ALWAYS USE A TORQUE WRENCH WHEN ADJUSTING SADDLE CLAMP BOLTS.

11. Install fender against rear linkage by placing the fender magnet on the front saddle clamp bolt.
12. Adjust saddle height if necessary.

MAINTENANCE:

The ShockStop Seatpost is designed to run quietly and smoothly with minimal maintenance. If you encounter any issues with your seatpost, please visit www.redshiftsports.com/faq for instructional videos and troubleshooting help, or contact us at support@redshiftsports.com.

NOTE: DO NOT USE GREASE OR ANY LUBRICATION ON PIVOT BUSHINGS. THEY ARE DESIGNED TO RUN DRY AND WILL PERFORM BETTER AND LAST LONGER WITH NO LUBRICANT.

⚠ WARNING

- Failure to follow these instructions and warnings may result in malfunction or breakage of this component, possibly causing serious injury or death.
- Always use a torque wrench when installing or adjusting fasteners, and always tighten to Redshift torque specifications (or the bike manufacturer's torque specification). Periodically check all fasteners for tightness using a torque wrench, since fasteners can loosen under the influence of road vibration.
- This seatpost is designed for use in a circular seat tube. It may be used with larger seat tube diameters by using an appropriate diameter shim at least 100mm (4 in.) in length.
- Do not raise the post beyond the minimum insertion line.
- For metal-framed bicycles, ensure that the post and the inside of the seat tube are covered with a thin layer of bicycle grease prior to installation. Failure to do so may cause the post to seize inside the bicycle frame.

- Periodically clean and inspect all surfaces of this component for hairline cracks or signs of damage. If you find any cracks or damage, immediately cease using the part and contact Redshift Sports customer service.
- Intended Use: ASTM F2043 Class 2 - For on and off-road riding and drops less than 15cm (6"). It is NOT intended for extreme off-road use or jumping.
- Excessive "bottom-out" of the suspension seatpost (i.e. riding with insufficient preload) can cause damage or result in breakage of the component.
- Seatpost is not compatible with rear luggage racks which clamp directly to the seatpost tube.
- Never place your hands or fingers near the seatpost linkages while riding. Doing so may cause pinching or crushing injuries.
- Seatpost is not compatible with rear-mounted child carriers.