

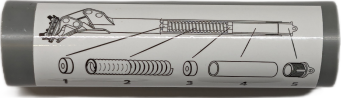

# Di2 Installation Instructions for 27.2mm ShockStop Seatpost

Thank you for purchasing the ShockStop Suspension Seatpost Di2 Battery Mounting Kit. This kit is only compatible with **27.2mm x 350mm** length ShockStop seatposts. **If you purchased your seatpost prior to Oct. 2023, please note the alternate instruction at the bottom of the page marked with \* in step 1.** If you have any questions, please reach out to support@redshiftsports.com.

**1** Remove preload plug and solid spring spacer from seatpost. Turn seatpost upside-down and install spring endcap below spring(s) as depicted on the hollow spring spacer\*



hollow spring spacer



o-rings
spring endcap

**2** Install 1 o-ring on the top groove of the battery



Ensure there is a light coat of grease on the o-ring (pro tip: you can use some grease from the seatpost spring if needed)

**3** Slide the battery into the hollow spring spacer until it is just below the top of the spacer. You may have to wiggle the battery and o-ring to get it started.



**4** Slide the second o-ring onto the battery until it touches the bottom of the spacer

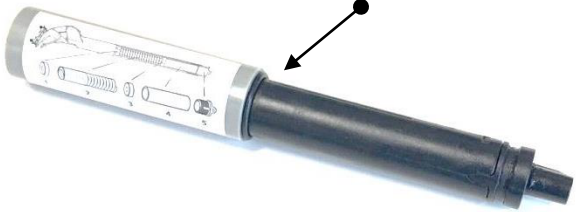

**5** Install the spacer and battery into seatpost



**6** Lightly grease the inside face of the preload plug and reinstall. Set desired preload.



\*For seatposts purchased before Oct. 2023, simply remove the preinstalled hollow spring spacer from the seatpost and proceed to step 2.

Note: The Di2 battery will protrude from the end of the seatpost as shown. It should be snug inside the seatpost but will move if pulled.

**⚠ WARNING**

Failure to follow these instructions and/or improper installation or use may result in malfunction or breakage of the battery and/or seatpost.