

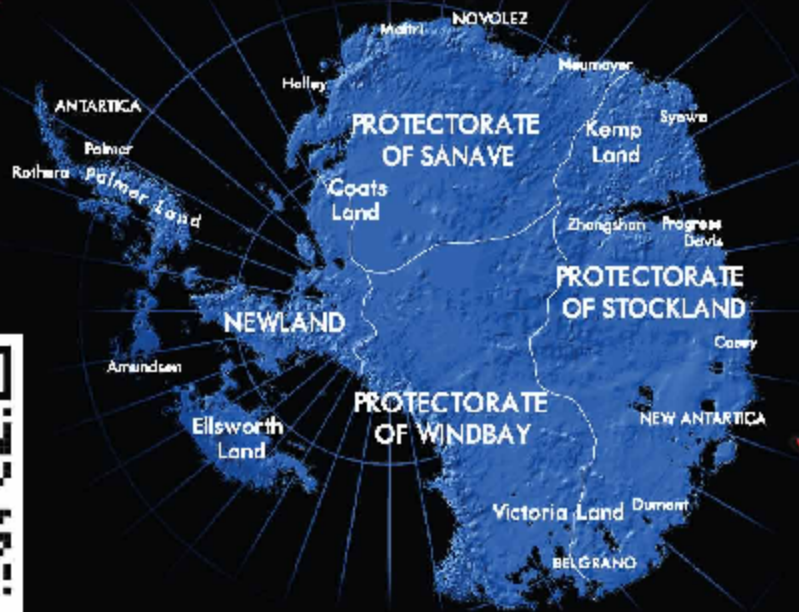

ANTARTICA

A TALE BY SAB



ANTARTICA – A TALE BY SAB

Year ZERO: TOTAL DESTRUCTION

In the 21st century, a nuclear war triggered by a group of cyber terrorists, caused the immediate destruction of a large part of the world's population.

The nuclear winter and the radioactive fallout drastically reduced the survivors and mankind found itself on the verge of extinction. Only a few well-organized groups of people survived in the southern hemisphere south of the 40th parallel.

Year 0-300: DARK CENTURIES

During the first three centuries, most of the planet was burned and became inhabitable. The widespread global fires generated large quantities of toxic gases that released nitrogen monoxide into the atmosphere depleting the ozone layer.

Global warming was certain and inevitable.

Mankind found itself facing dark centuries, during which most of the technological advances civilization had achieved were lost; cultural knowledge and law and order were non-existent, even the most basic human rights were violated.

Year 300-400: A NEW OPPORTUNITY

As the polar ice caps started to melt, the human race found new hope.

The new climatic conditions of the Antarctic continent allowed for the growth of countless of settlements.

In the year 397, the city of Antarctica was proclaimed the capital of Newland and became the most important cultural, economic and commercial center on planet Earth.

Year 400-500: A NEW POLITICAL SYSTEM

The Antarctic continent was completely colonized by the state of Newland, which established a federation of three dependent states or protectorates: Sanave, Windbay and Stockland, with their own respective capitals of Novolez, Belgrano and New Antarctica.

Thanks to its favorable geographical location, the Stockland protectorate had such an economic growth that, around the year 450, New Antarctica, its capital became extremely important to the federal capital, Antarctica.

Year 512: THE REVOLUTION: HISTORY REPEATS ITSELF

The desire for freedom coupled with discontent due to the high taxation imposed on the protectorates by the state of Newland led to independence movements, which resulted in a declaration of independence of the Stockland protectorate on October 4th, 512. As tensions rose, a battle of independence was inevitable and on June 21st, 513, the Battle of Kemp, a violent air battle between the rebel legion of New Antarctica and the elite army of Newland took place.

The arms race had begun.

ANTARTICA

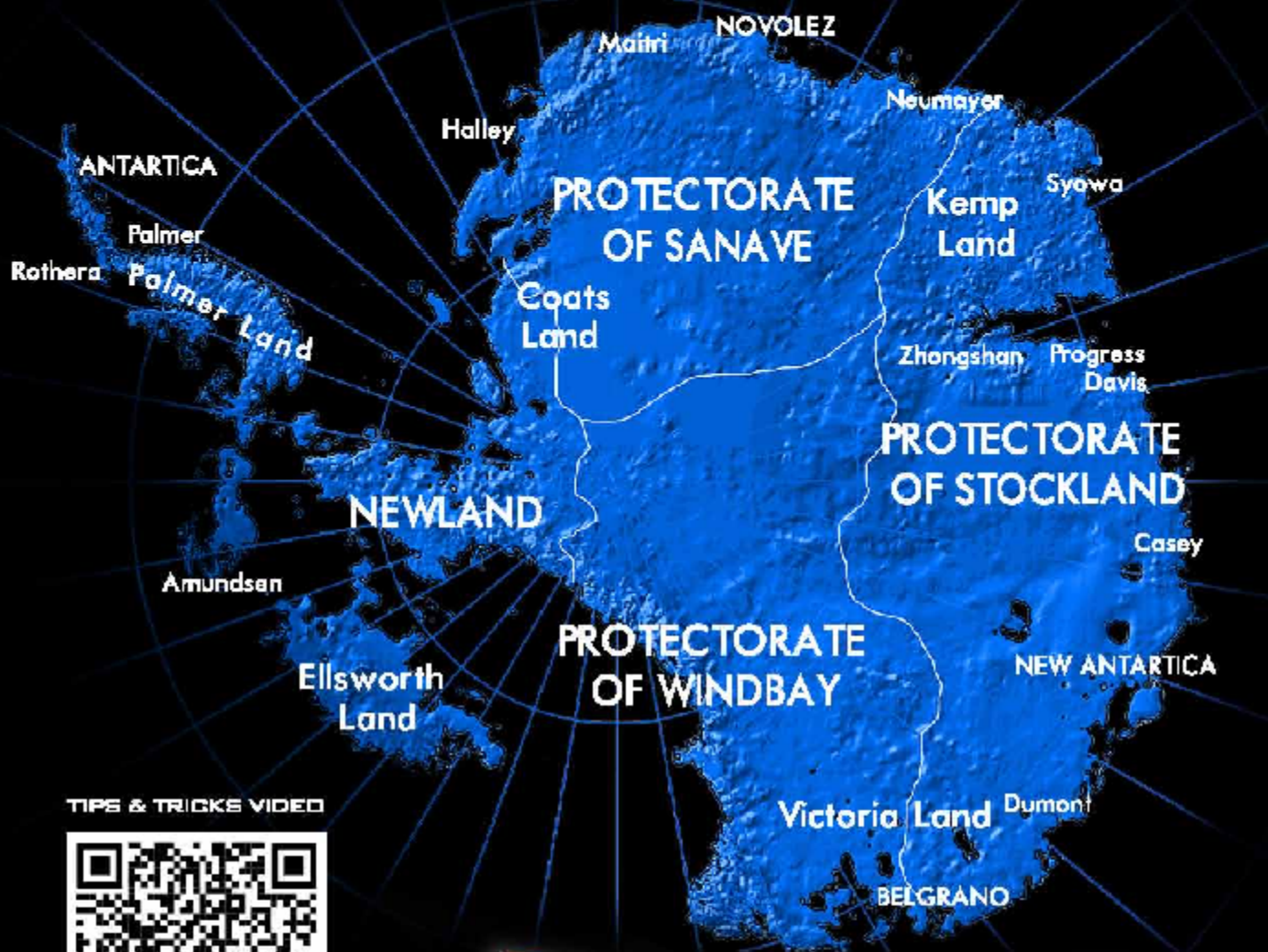

TIPS & TRICKS VIDEO



SAB AVIO WEBSITE



TORTUGA MANUAL
Release 1.2 - August 2018

SAB AVIO
www.sabavio.com
support@sabitaly.com



NAME: KR84 TORTUGA

VERSION: Robodrone

ROLE: Reconnaissance and attack

MANUFACTURER: Kruger Industries

Please read this user manual carefully, it contains instructions for the correct assembly of the model.
Please refer to the web site www.sabavio.com for updates and other important information.

VERY IMPORTANT

In the Manual bag you will find a product card with your serial number. Please take a moment to register your kit online via our website:

www.sabavio.com

It is extremely important that you take a moment to register your airplane with us. This is the only way to ensure that you are properly informed about changes to your kit, such as upgrades, retrofits and other important developments. SAB Avio cannot be held responsible for issues arising with your model and will not provide support unless you register your serial number.

Thank you for your purchase, we hope you enjoy your new Tortuga!

SAB Avio Team

SPECIFICATIONS

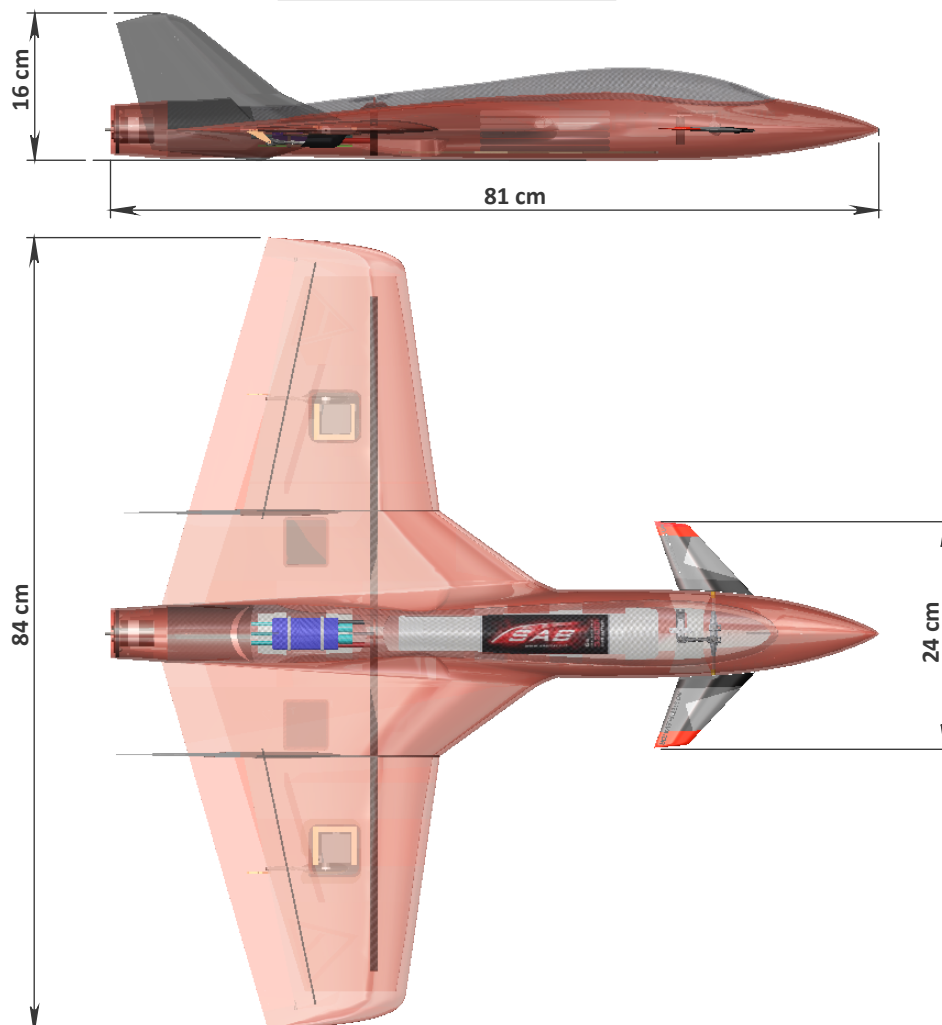

This is the semi-scale 1/8 model of the KR84 Tortuga ROBO DRONE Version that fought in the Kemp battle of 513

Wing Span	: 84 cm	Set up suggested:
Wing Area	: 2400 cm ²	6S -- 2600/3200 mAh
Maximum Length	: 81 cm	2200 kV motor inrunner, 28-36mm
RTF Weight	: 1.5 Kg	120A ESC
Maximum Total Weight	: 1.7 Kg	Max Motor Size
		*36mm diameter electric motor, 150 grams
		Battery Compartment: 55x45x200 mm

IMPORTANT NOTES

- *This radio controlled airplane is not a toy.
- *This radio controlled airplane can be very dangerous.
- *This radio controlled airplane is a technically complex device which has to be built and handled very carefully.
- *This radio controlled airplane must be built following these instructions. This manual provides the necessary information to correctly assemble the model. It is necessary to carefully follow all the instructions.
- *Inexperienced pilots must be monitored by expert pilots.
- *All operators must wear safety glasses and take appropriate safety precautions.
- *A radio controlled airplane must only be used in open spaces without obstacles, and far enough from people to minimize the possibility of accidents or of injury to property or persons.
- *A radio controlled airplane can behave in an unexpected manner, causing loss of control of the model, making it very dangerous.
- *Lack of care with assembly or maintenance can result in an unreliable and dangerous model.

***Neither SAB Avio nor its agents have any control over the assembly, maintenance and use of this product. Therefore, no responsibility can be traced back to the manufacturer. You hereby agree to release SAB Avio from any responsibility or liability arising from the use of this product.**

SAFETY GUIDELINES

- *Fly only in areas dedicated to the use of model.
- *Follow all control procedures for the radio frequency system.
- *It is necessary that you know your radio system well. Check all functions of the transmitter before every flight.
- *The propeller of the model rotate at a very high speed; be aware of the danger they pose and the damage they may cause.
- *Never fly in the vicinity of other people.

DAMAGE LIMITS

SAB AVIO SHALL NOT BE LIABLE FOR SPECIAL, INDIRECT OR CONSEQUENTIAL DAMAGES, LOSS OF PROFITS OR PRODUCTION OR COMMERCIAL LOSS IN ANY WAY CONNECTED WITH THE PRODUCT, WHETHER SUCH CLAIM IS BASED IN CONTRACT, WARRANTY, NEGLIGENCE, OR STRICT LIABILITY. Further, in no event shall the liability of SAB Avio exceed the individual price of the Product on which liability is asserted. As SAB Avio has no control over use, setup, final assembly, modification or misuse, no liability shall be assumed nor accepted for any resulting damage or injury. By the act of use, setup or assembly the user accepts all resulting liability. If you as the Purchaser or user are not prepared to accept the liability associated with the use of this Product, you are advised to return this Product immediately in new and unused condition to the place of purchase.

LIMITED WARRANTY.

SAB Avio reserves the right to change or modify this warranty without notice and disclaims all other warranties, express or implied.
(a) This warranty is limited to the original Purchaser (“Purchaser”) and is not transferable. REPLACEMENT AS PROVIDED UNDER THIS WARRANTY IS THE EXCLUSIVE REMEDY OF THE PURCHASER This warranty covers only those Products purchased from an authorized SAB Avio dealer. Third party transactions are not covered by this warranty. Proof of purchase is required for warranty claims.
(b) Limitations- SAB AVIO MAKES NO WARRANTY OR REPRESENTATION, EXPRESS OR IMPLIED, ABOUT NONINFRINGEMENT, MERCHANTABILITY OR FITNESS FOR A PARTICULAR PURPOSE OF THE PRODUCT. THE PURCHASER ACKNOWLEDGES THAT THEY ALONE HAVE DETERMINED THAT THE PRODUCT WILL SUITABLY MEET THE REQUIREMENTS OF THE PURCHASER’S INTENDED USE.
(c) Purchaser Remedy- SAB Avio’s sole obligation hereunder shall be that SAB Avio will, at its option, replace any Product determined by SAB Avio to be defective In the event of a defect, this is the Purchaser’s exclusive remedy. Replacement decisions are at the sole discretion of SAB Avio. This warranty does not cover cosmetic damage or damage due to acts of God, accident, misuse, abuse, negligence, commercial use, or modification of or to any part of the Product. This warranty does not cover damage due to improper installation, operation, maintenance or attempted repair by anyone

NOTES FOR ASSEMBLY

Please refer to this manual for assembly instructions for this model. Follow the order of assembly indicated. The instructions are divided into chapters, which are structured in a way that each step is based on the work done in the previous step. Changing the order of assembly may result in additional or unnecessary steps.
 Use thread lockers and retaining compounds as indicated. In general, each bolt or screw that engages with a metal part requires thread lock. It is necessary to pay attention to the symbols listed below:



Sand and fit where necessary



Mill



Use Thread Locker Medium Strength (SAB HA116-S)



Use CA Glue



Use Epoxy Glue



Bag xx Indicates that for this assembly phase you need materials that are in bag xx.

Inside the box

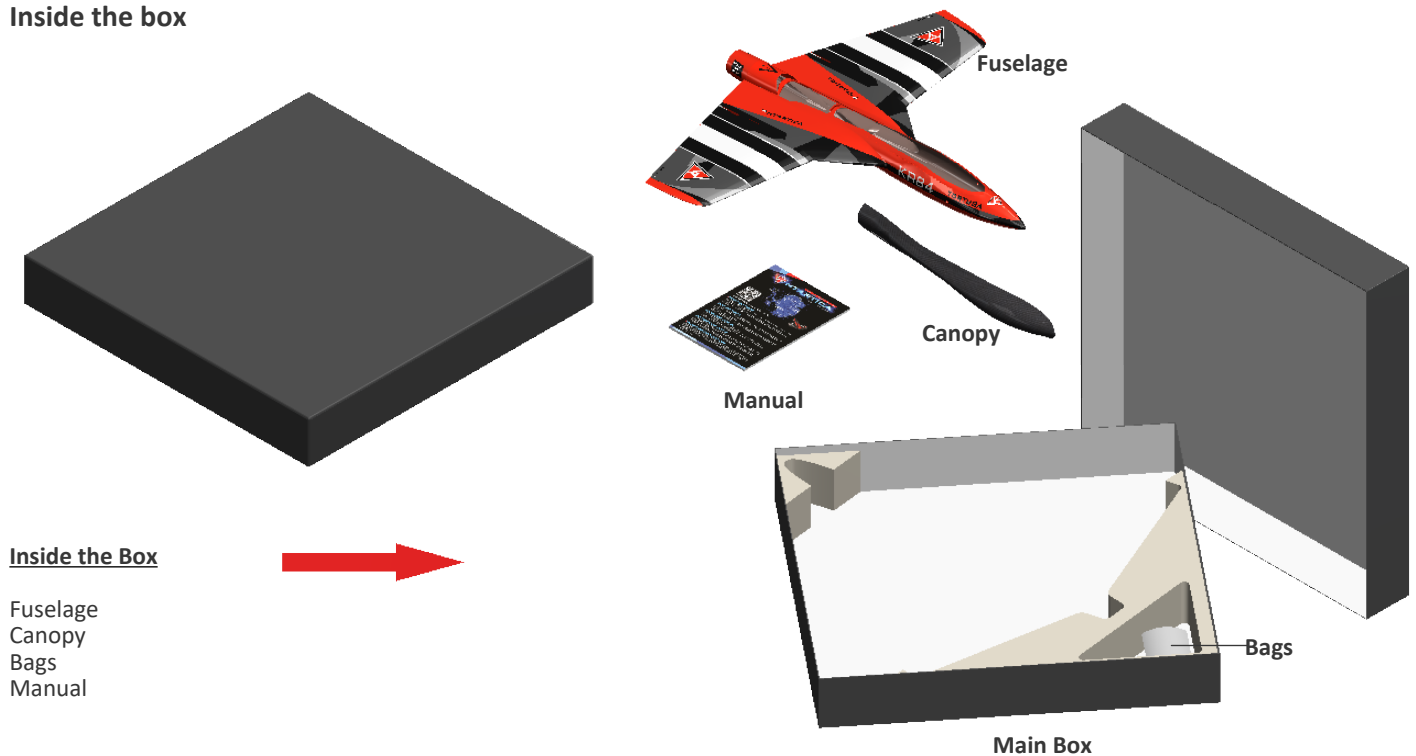

Inside the Box

Fuselage
Canopy
Bags
Manual

The assembly process is described in the following chapters. Each chapter provides you with the bag number you will need for that chapter. The information is printed in a red box in the upper right corner of the page at the beginning of every chapter.

ADDITIONAL COMPONENTS REQUIRED

Electric Motor: Maximum diameter 40mm.
Speed Controller (ESC): Suitable for own configuration.
Batteries.
4/6 channel radio control system
Radio power system.
1 Canard servo (Micro servo size 23mm).
2 Wing servos, maximum thickness 10mm.
3 Servo Extension Cords, if necessary.
1 Propeller adaptor.
1 Propeller.

TOOLS AND ADHESIVES

Drill with drill bits 2, 3, 4mm.
Small milling cutter for drill.
Generic pliers.
Hexagonal driver, size 1.5, 2, 2.5, 3 mm.
Cyano-acrylate glue.
Epoxy glue.
Medium threadlocker (eg. Loctite 243).
Soldering equipment (for electric wiring).

Motor Mount Assembly

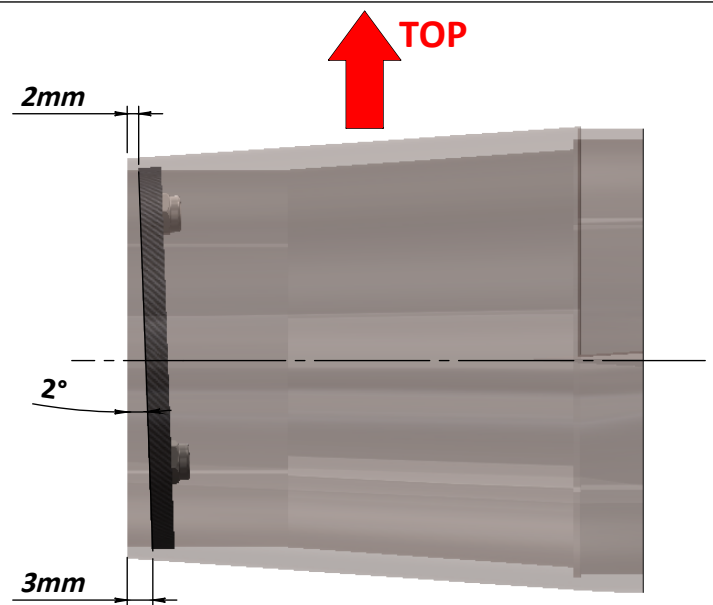
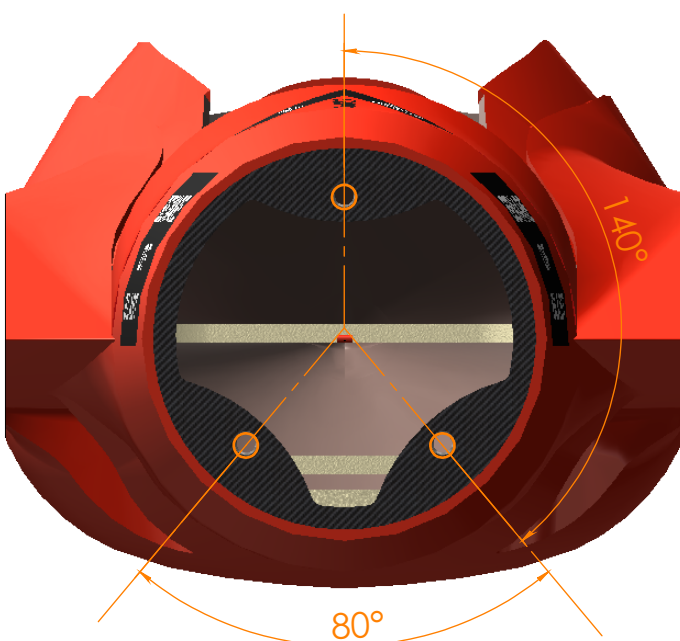
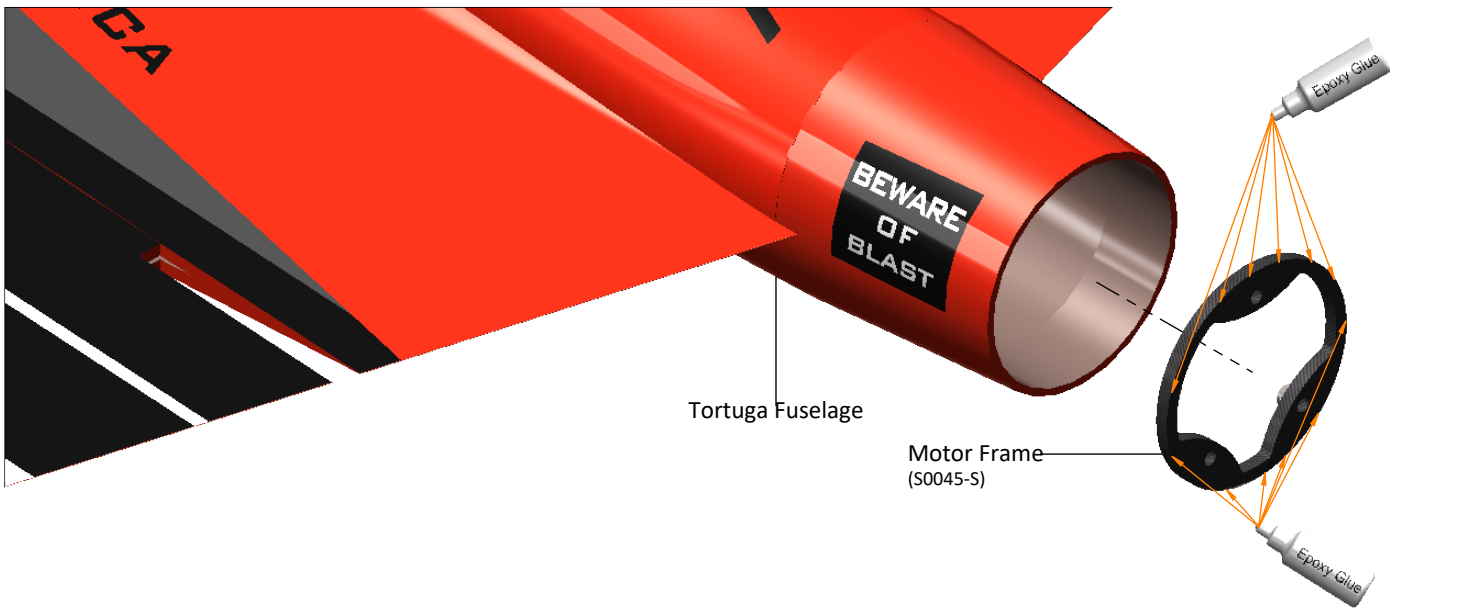
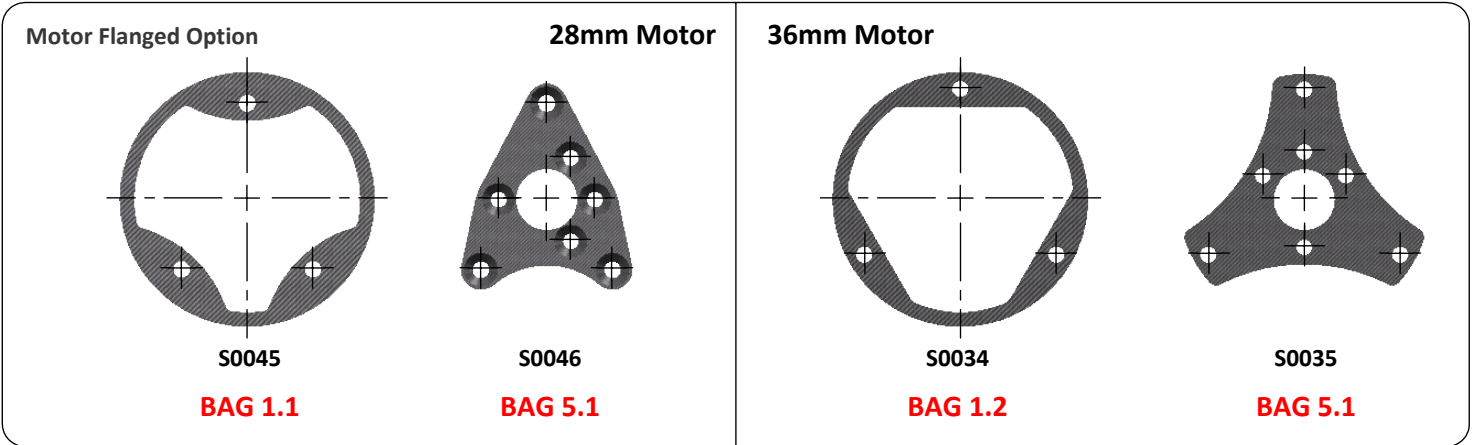

Incline about 2° the motor mount. It is possible to set the right inclination of motor shaft just adding washers between Motor Frame and Motor Mount.

Canard Mechanics Assembly

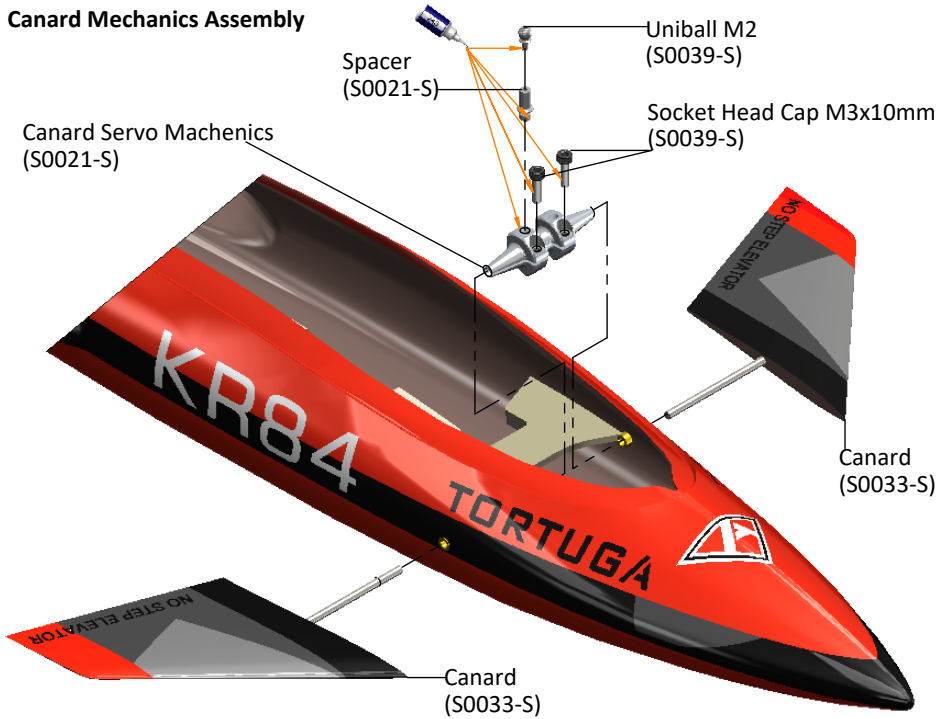

Servo Rod Assembly (S0039-S)

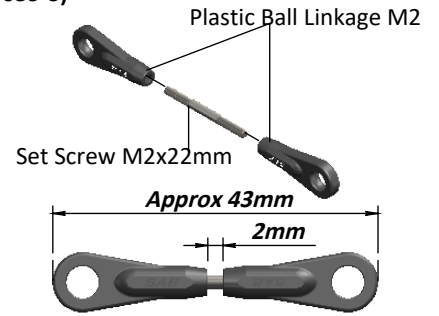

Canard Servo Assembly
Micro servo size : 23mm

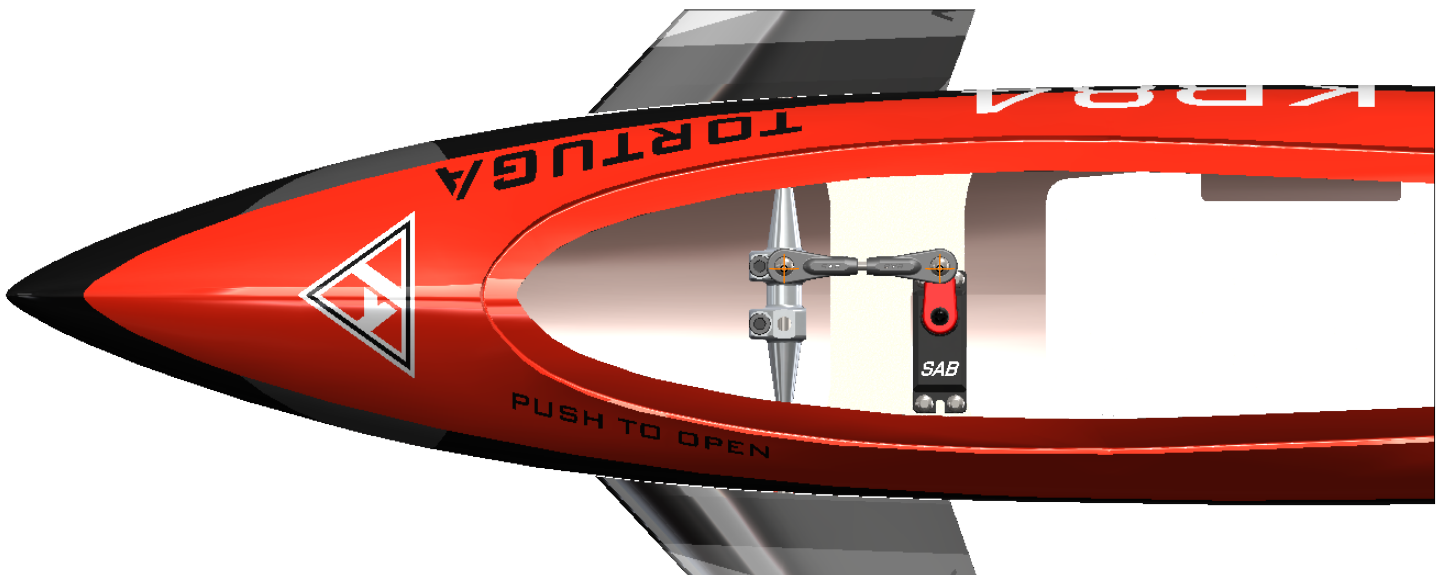
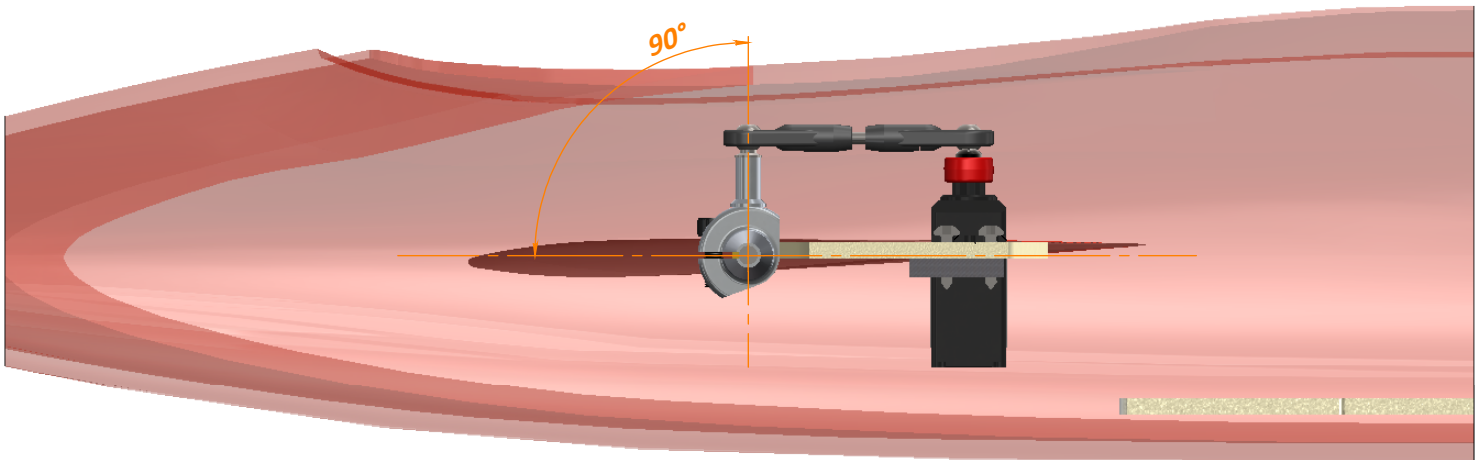
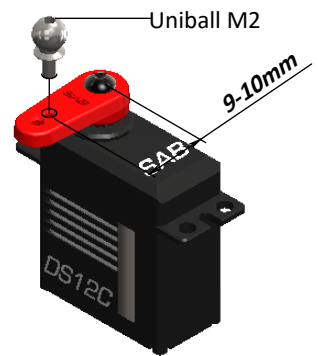

Aileron Servo Linkage Assembly (S0039-S) ...x2



Aileron Servo Mount Assembly ...x2

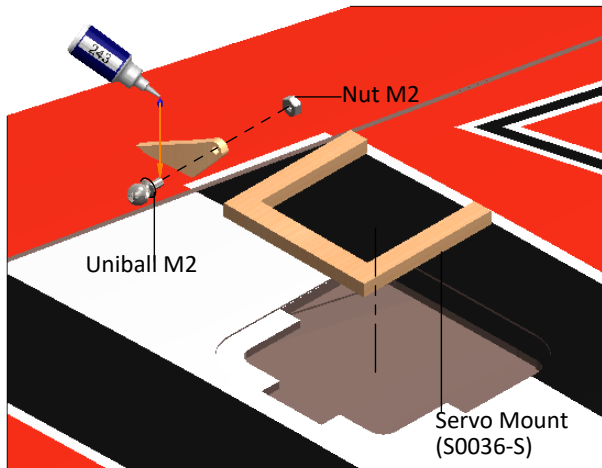

Note: Use epoxy to glue in the servo mount. Check the suggested position in according to the size of your servo.

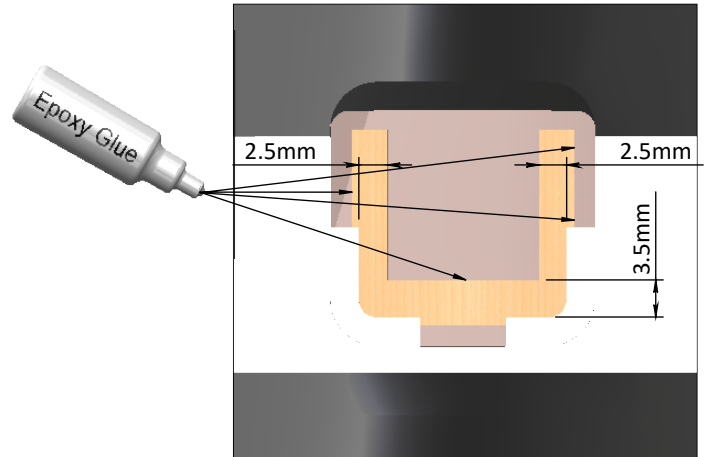

Aileron Servo Assembly ...x2

Aileron Servo Wing Servo 30x30x10

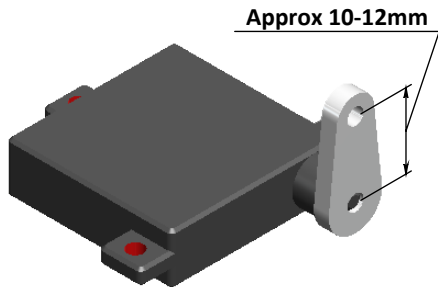

Aileron Servo Linkage Assembly

Socket Self Tapping Screw M2.9x6.5mm.

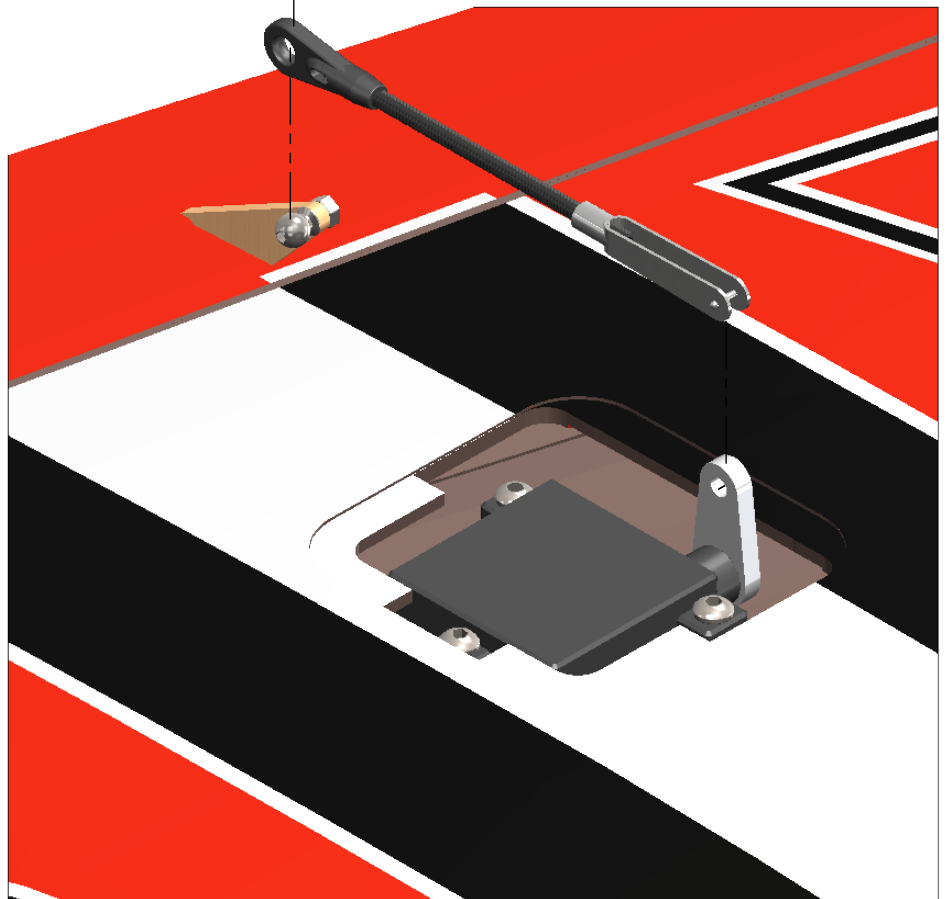
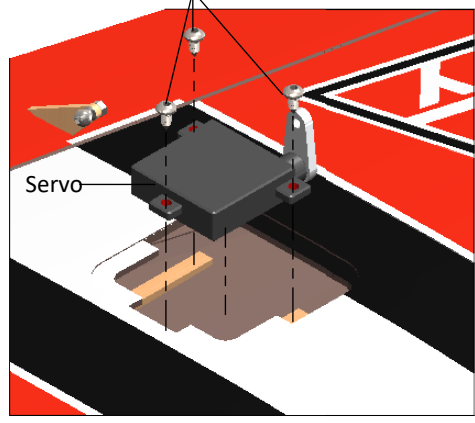

Aileron Servo Cover Positioning

Aileron Servo Cover (S0037-S)

Cover Stick (HC525-S)

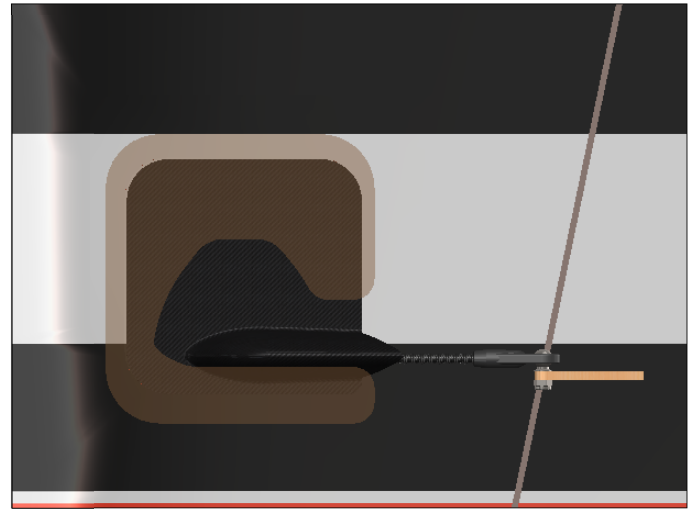
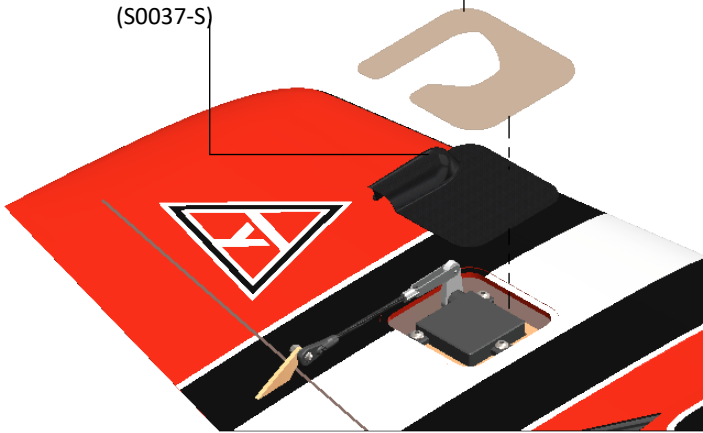

Rudder Positioning

Rigid Vertical Rudder (S0031-S)

NOTE:

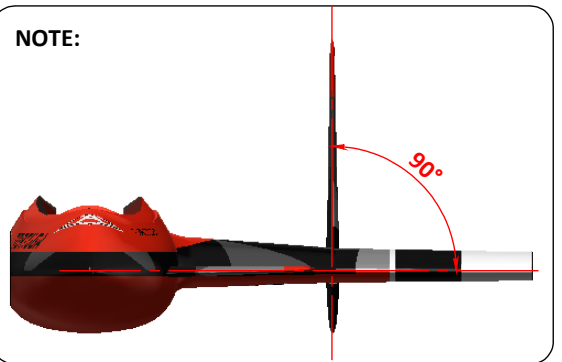

Suggest: To avoid dirtying the joining area, it is recommended to protect it with paper tape during the gluing operation.

It is also recommended to use sandpaper to prepare the surface in the gluing area.

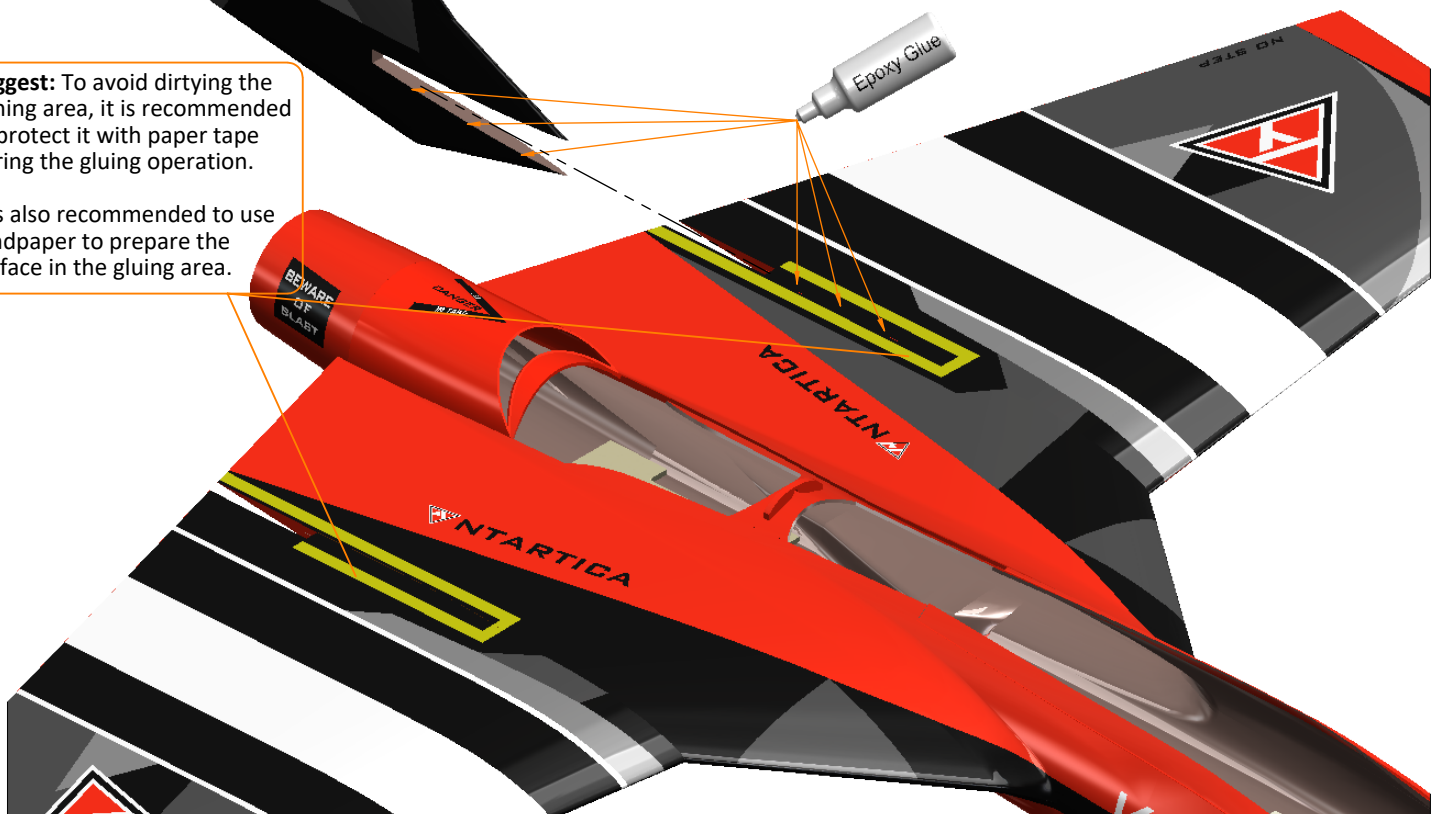

Motor Installation

Find better holes for motor coupling.
Drill if necessary to facilitate installation.

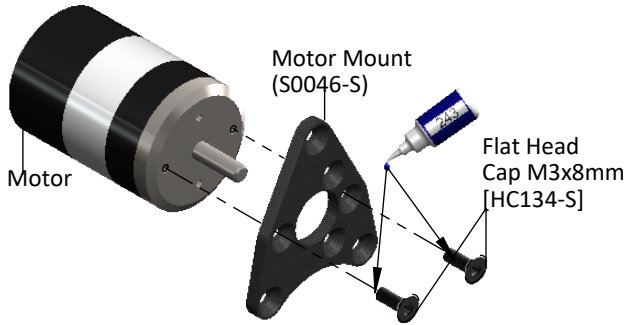

WARNING ⚠️
Before assembling the screws to the motor, check if the length of the M3x8 screws is compatible with the motor. If they are too long they can damage the motor inside and therefore, screws must be cut off.
NOTE: It is recommended to use an aluminum heatsink for the motor.

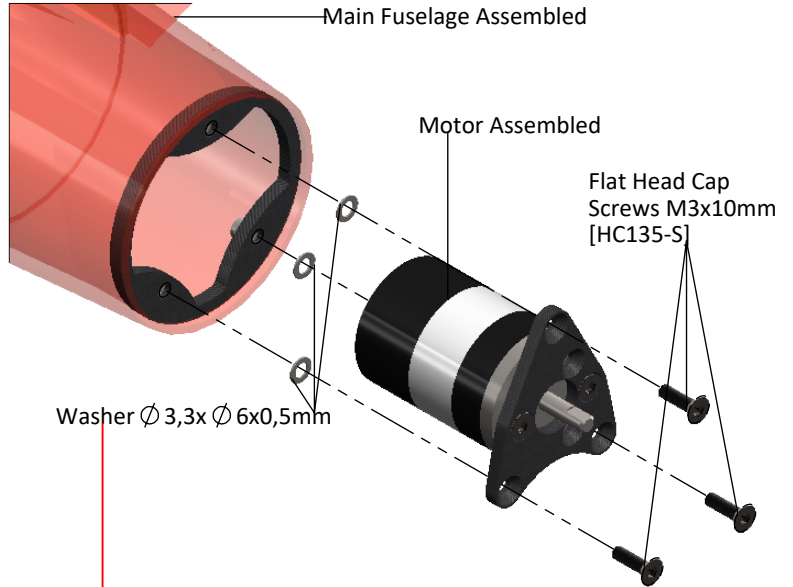

NOTE: USE shim to adjust motor angle if necessary

ESC frame Positioning

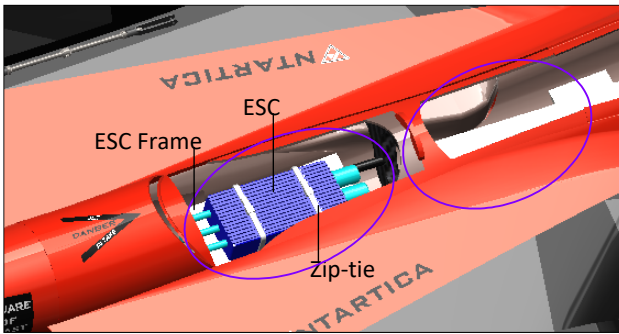

The ESC can be installed in the 2 positions shown. In according with your setup choose the best position to get a correct CG. Use Zip-tie to keep ESC in position.

Hook for Launch

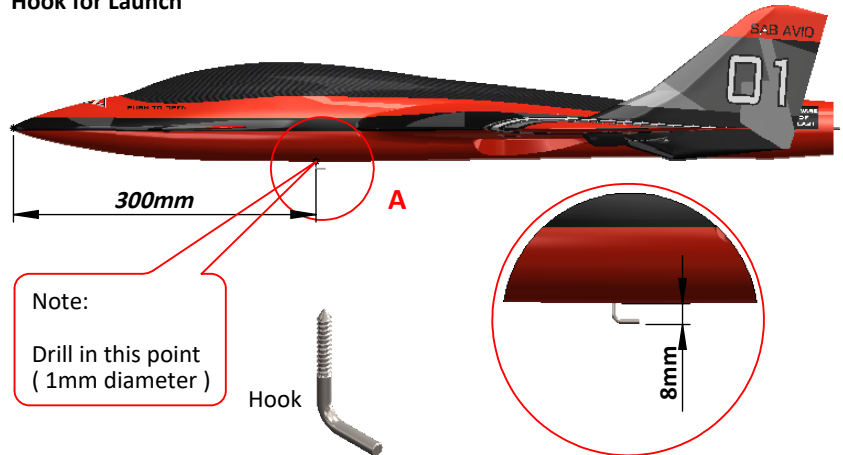

Canopy springs positioning

NOTE: To define the end-movement of the canopy, cut the plastic tube to the optimal length (about 28 mm), verifying the perfect positioning. Add a small drop of CA glue to keep tube in position.

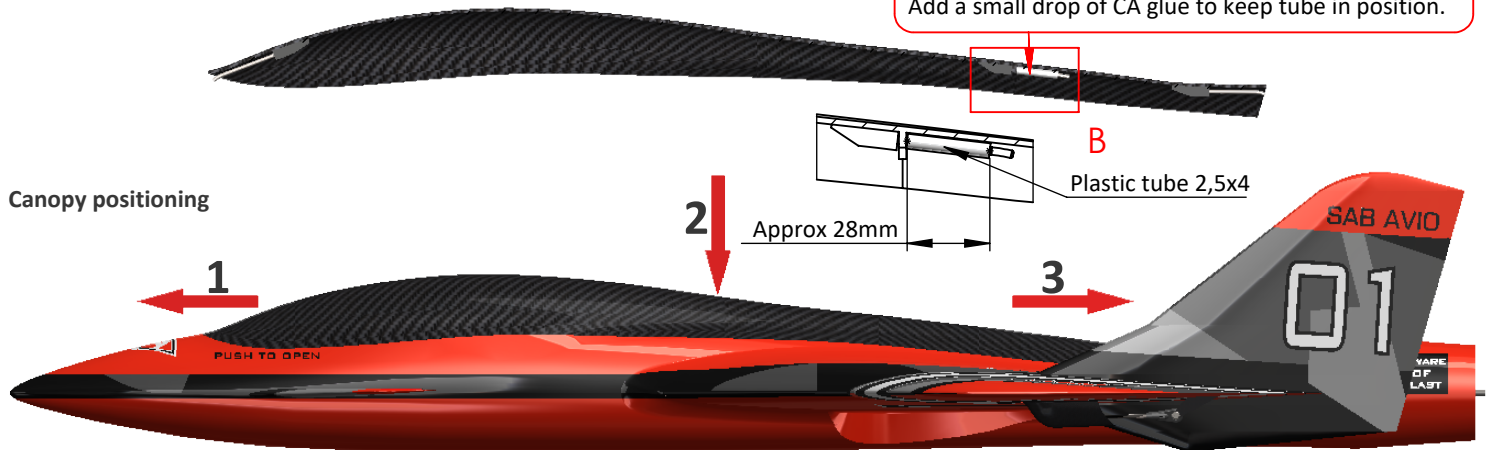

1. Put front spring into front holder and push forward the canopy in order to permit rear spring positioning.
2. Push down the canopy on the fuselage.
3. Put rear spring into rear holder and put the end of the canopy under the fuselage.

⚠️ Be carefull when you put on or take off carbon canopy to avoid scratches on the paint.

Center of Gravity Position

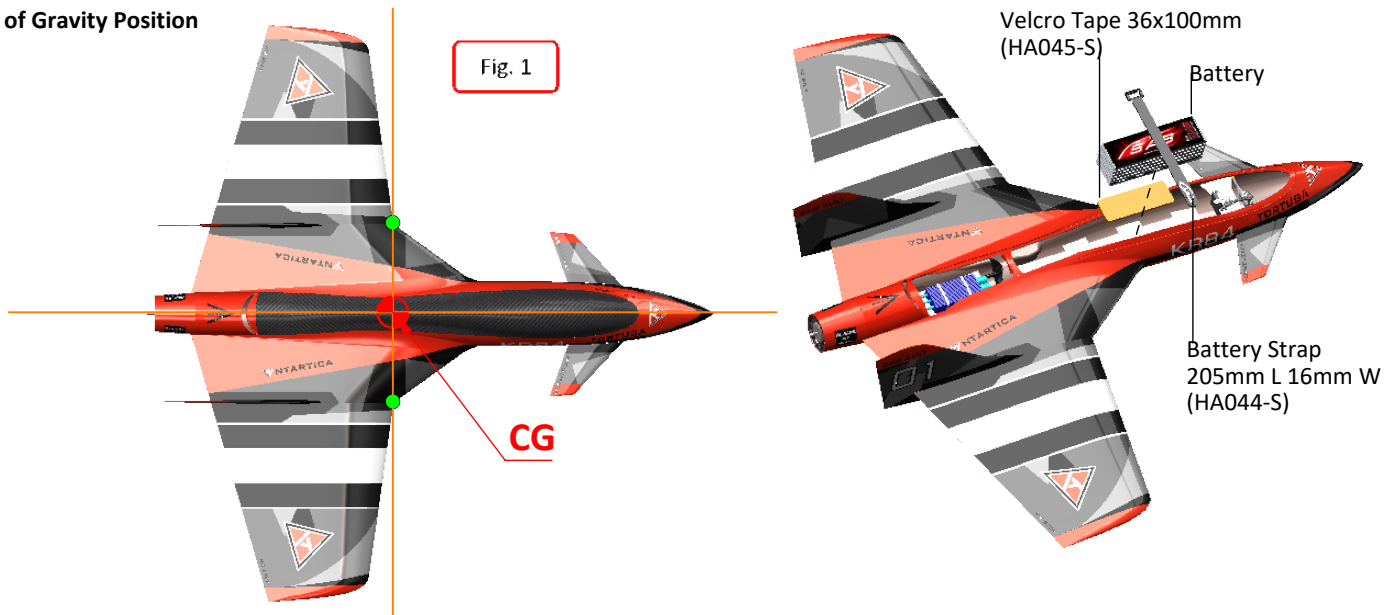

Set the Battery in order to get the correct position of the Center of Gravity (CG) shown in figure 1. The right CG position allow to fly with an excellent stability. If it is necessary add weight (lead) in the nose.

Radio settings



Mix the canard rotation with elevator deflection. When elevator go up, the canard should increase its incidence as in figure 2.

Set minimum two flight conditions, indicated in table below.

	Low Speed Condition		High Speed Condition	
	Deflection	Exponential	Deflection	Exponential
Ailerons	± 12 mm	50%	± 6 mm	60%
Elevator	± 12 mm	50%	± 6 mm	60%
Canard	± 8 mm	-	± 3 mm	

Radio test and pre flight check

 Before try the airplane, check the radio and check the reception on distance. Check the movement of each parts. Before any flight check CG position and be sure the battery is well fixed.

The size of the propeller depends on the setup used. With the recommended setup, we suggest starting with a 5x5 propeller. Verify the current absorption of your motor / propeller setup.

First flight

 The propeller of the model rotate at a very high speed; be aware of the danger they pose and the damage they may cause.

Launch the TORTUGA against the wind with motor at maximum with radio in low speed condition. We advise catapult-launching for the first flights. The launch angle must be minimum 30° as in figure 3.



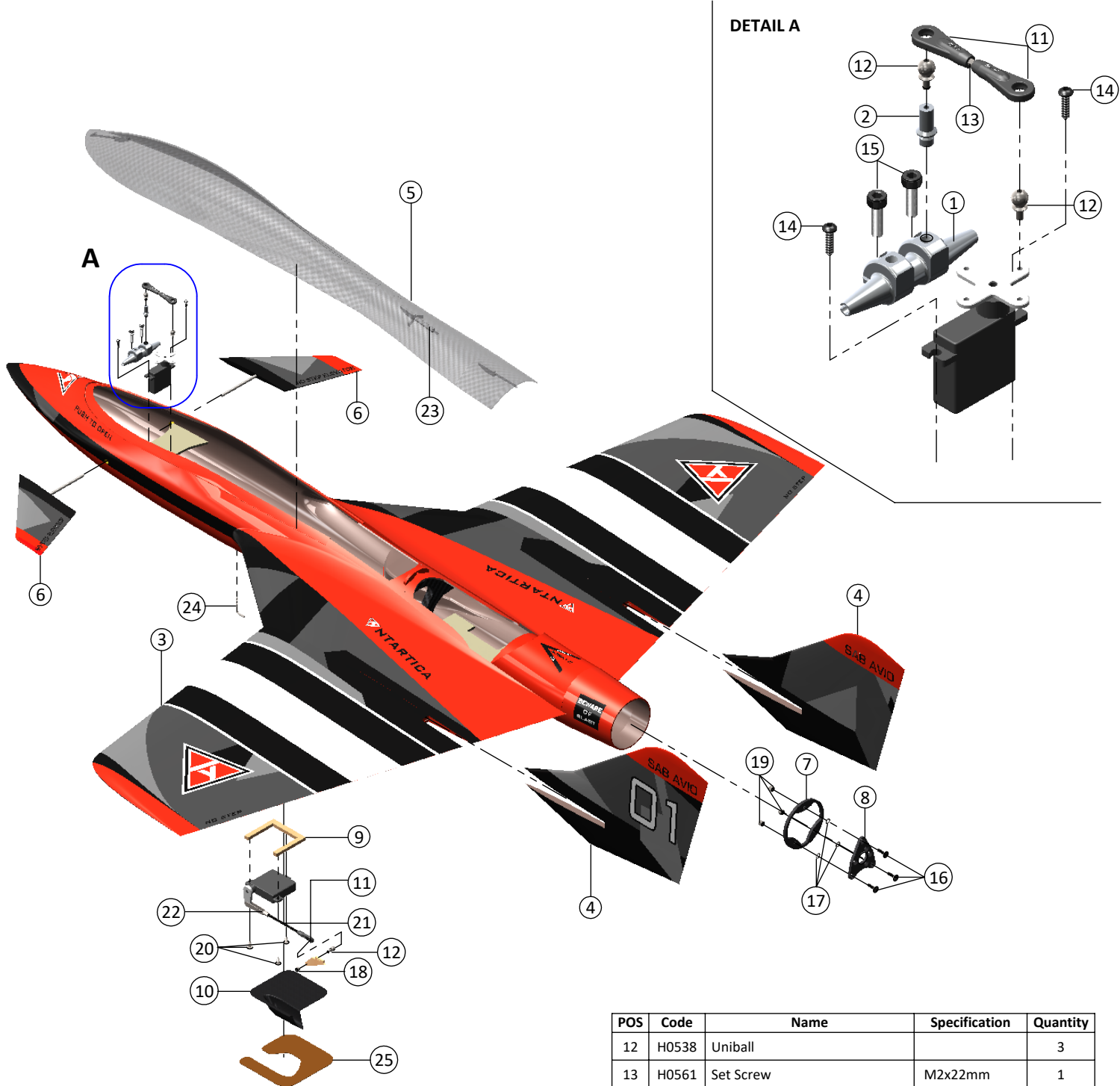

POS	Code	Name	Specification	Quantity
1	S0021	Canard Collar	Aluminum	1
2	S0022	Spacer	Aluminum	1
3	S0030	Fuselage		1
4	S0031	Rigid Vertical Rudder		2
5	S0032	Canopy	Carbon Fiber	1
6	S0033	Canard	Carbon Fiber	2
7	S0045	Motor Frame	Carbon Fiber	1
8	S0046	Motor Mount	Carbon Fiber	1
9	S0036	Servo Mount	30x35.5mm	2
10	S0037	Aileron Servo Cover	Carbon Fiber	2
11	H0403	Plastic Ball Link	Plastic	4

POS	Code	Name	Specification	Quantity
12	H0538	Uniball		3
13	H0561	Set Screw	M2x22mm	1
14		Socket Self Tapping Screw	M2.2x10mm	2
15	HC056	Socket Head Cap	M3x10mm	2
16	HC135	Flat Head Cap	M3x10mm	3
17	HC180	Washer	Ø 3.3x Ø 6x0.5	3
18	HC197	Nut	M2	2
19	HC206	Nylon Nut	M3	3
20	HC244	Linkage Rod M2x56mm	M2x56mm	2
21	HC521	Socket Self Tapping Screws	M2.9x6.5mm	6
22	HC522	Clevis	M2.5	2
23	HC523	Plastic Tube	Ø 2.5x Ø 4	1
24	HC524	Hook		1
25	HC525	Cover Stick	Carbon Fiber	4

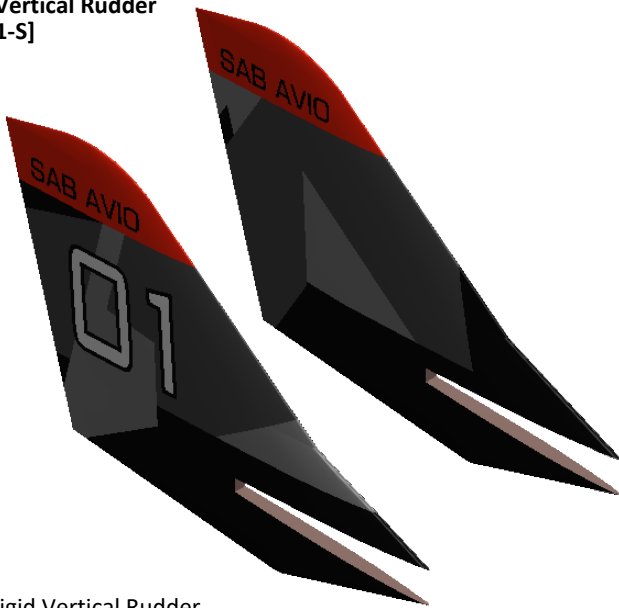
Rigid Vertical Rudder
 [S0031-S]

- 2 x Rigid Vertical Rudder.

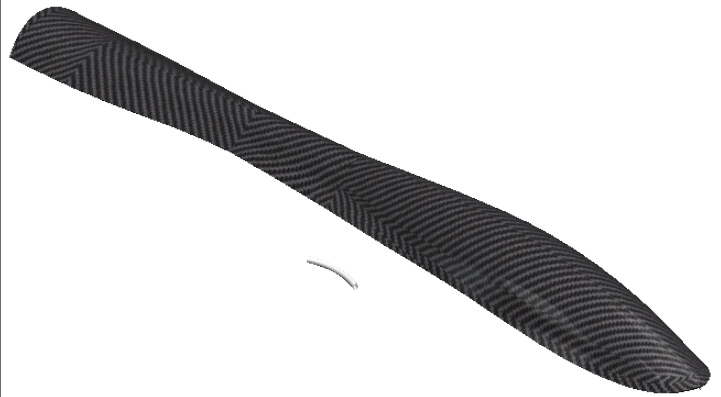
Canopy
 [S0032-S]

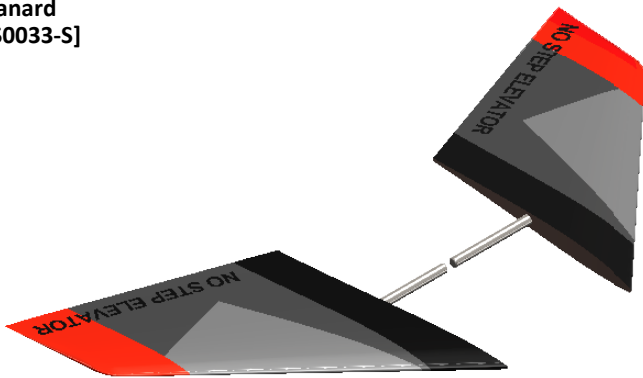
 - 1 x Canopy.
 - 1 x Plastic tube $\varnothing 2,5 \times \varnothing 4 \times 40 \text{mm}$.

Canard
 [S0033-S]

- 2 x Canard.

Motor Mount (36mm Motor Diameter)
 [S0035-S]

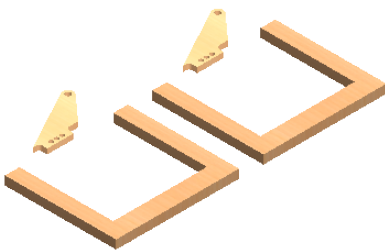
 - 1 x Motor Frame.
 - 1 x Motor Mount.
 - 3 x Flat Head Cap Screws M3x10mm.
 - 3 x Nylon Nut M3.
 - 3 x Washer $\varnothing 3,3 \times \varnothing 6 \times 0,5 \text{mm}$.

Servo Supports
 [S0036-S]

 - 2 x Servo Support 30x35,5mm.
 - 2 x Aileron Horn.

Aileron Servo Cover
 [S0037-S]

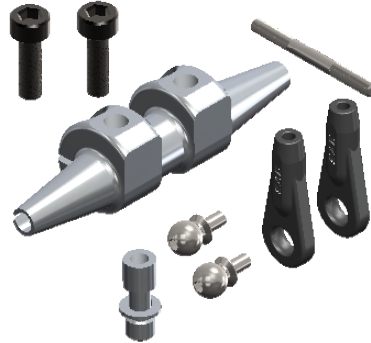
 - 2 x Aileron Servo Cover.
 - 4 x Cover Stick.

Canard Servo Mechanics
[S0021-S]

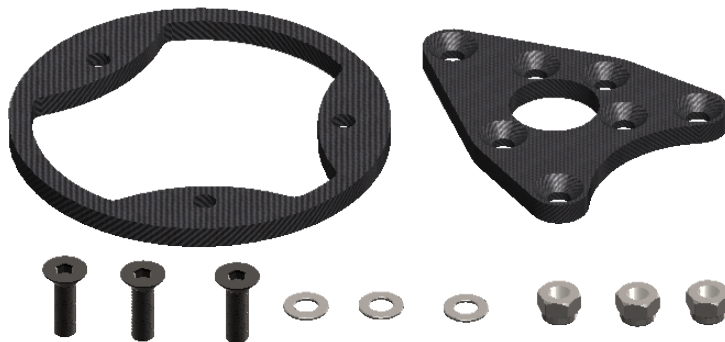
- 1 x Canard Servo Mecanics.
- 2 x Linkage Ball M2.
- 2 x Uniball M2.
- 2 x Socket Head Cap M3x10mm.
- 1 x Set screw M2x22mm.
- 1 x Spacer.

Motor Mount (28mm Motor Diameter)
[S0045-S]

- 1 x Motor Frame.
- 1 x Motor Mount.
- 3 x Flat Head Cap Screws M3x10mm.
- 3 x Nylon Nut M3.
- 3 x Washer $\varnothing 3,3 \times \varnothing 6 \times 0,5 \text{mm}$.

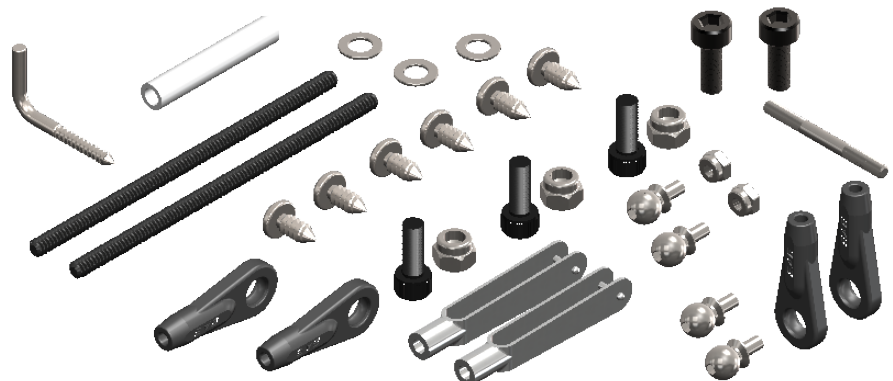
Hardware
[S0039-S]

- 4 x Plastic Ball Linkage.
- 4 x Uniball M2.
- 3 x Socket Head Cap Screw M3x10mm.
- 3 x Washer 3,3x 6x0,5mm.
- 3 x Metric Hex Nylon Nut M3.
- 2 x Linkage Rod M2x56mm.
- 6 x Socket Self Tapping Screw M2.9x6.5mm.
- 2 x Clevis.
- 2 x Metric Hex Nut M2.
- 1 x Hook.
- 1 x Plastic Tube $\varnothing 2.5 \times \varnothing 4$.
- 2 x Socket Head Cap M3x8mm.
- 1 x Set screw M2x22mm.

ANTARTICA

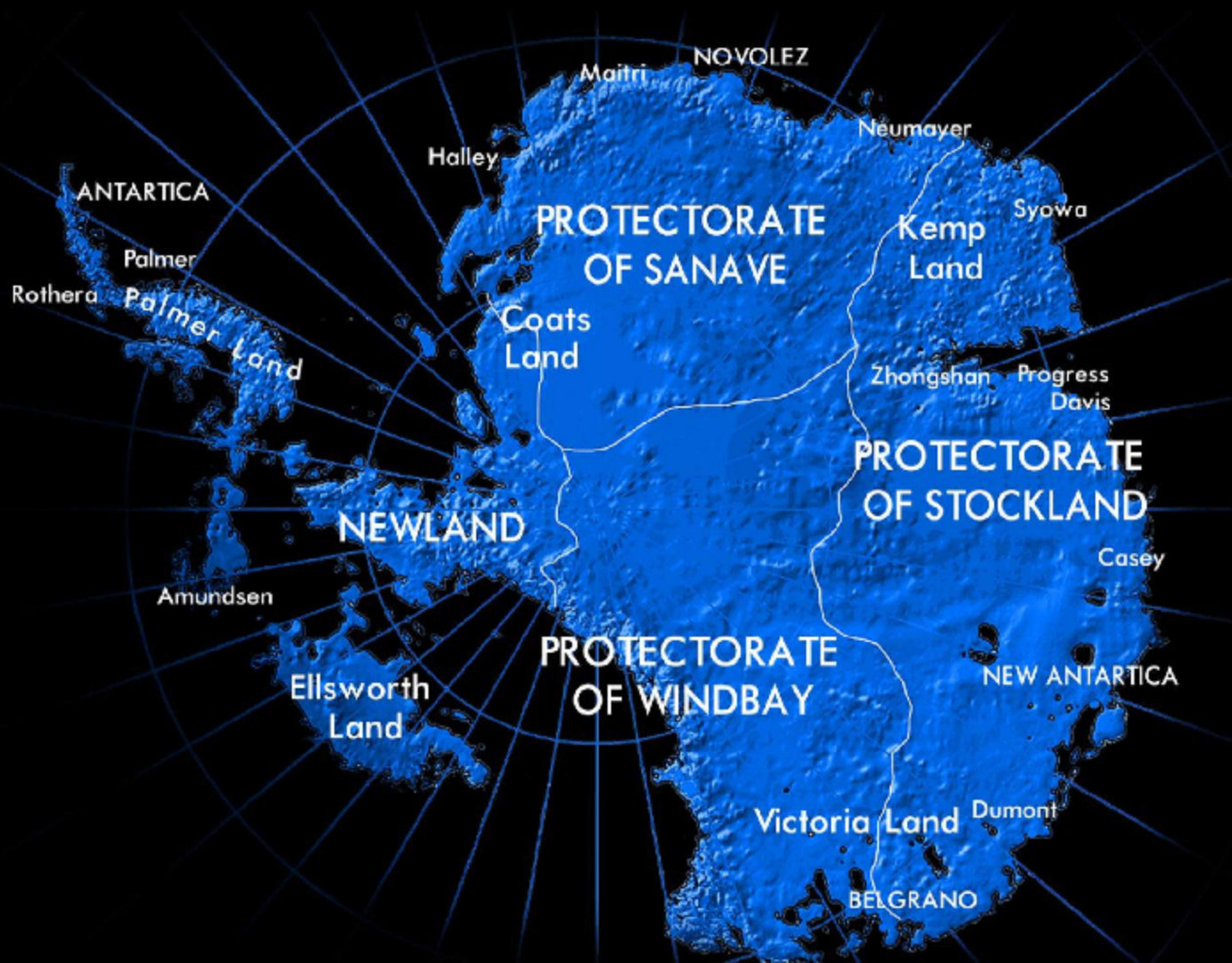

KEMP BATTLE

Year 513: THE BATTLE OF KEMP

After months of bankruptcy negotiations, the state of Newland organized a surprise attack with the purpose of destroying the military bases of Syowa, Progress and Davis and regain control of the self-proclaimed state of Stockland.

The attack was scheduled for June 21st, 513, the first day of winter, which later became famous as "dark day".

Thanks to intelligence acquired by the secret service of New Antartica, the rebel legion had prepared itself ahead of the attack and this led to the historic sky battle of Kemp.

On June 21st, Newland forces comprised of Robodrone Tortuga and Drake Bombers faced the Havok Multirole Fighter of the rebel brigade of Stockland.

The fierce battle caused serious losses to both sides without declaring a real winner.

Huge investments were later made by both parties to increase their arsenal and strengthen their fleet.



NAME: **KR84 TORTUGA**
VERSION: Robodrone
ROLE: Reconnaissance and attack
MANUFACTURER: Kruger Industries



NAME: **K175 DRAKE**
VERSION: Robodrone
ROLE: Multirole fighter
MANUFACTURER: Kruger Industries



NAME: **M169 HAVOK**
VERSION: Robodrone
ROLE: Multirole fighter
MANUFACTURER: Mc Murdo Industries

SAB AVIO WEBSITE



ANTARTICA MOVIE



TIPS & TRICKS VIDEO

