

YU XIANG

EC135 Scale Helicopter User Manual

F06



CE

FC

MADE IN CHINA



Table of Contents:

Introduction	1
Accessory List	1
Caution	2
Warning	2
Safety Precautions and Warnings	2
Helicopter Specifications	3
Warnings and Battery Usage Guide	3
Battery Charging	3
Battery Functions and Indicators	4
Remote Control Functions	5
Aircraft and Remote Control Frequency Binding	6
Aircraft Status Indicator Light Explanation	6
Gyroscope Calibration	7
Manual Motor Start/Stop	7
Aircraft Locking	8
First Flight	8
Main Control Board Socket Diagram	9
Optical Flow Mode Precautions	9
Manual Mode Flight	10
One-Key Landing	10
Expert Reverse Flight Mode	10
Pitch Setting	11
Common Troubleshooting	11

Introduction:

This model is a 1:32 scale replica of the EC135 helicopter, featuring highly realistic detailed appearance, cool lighting effects, and equipped with intelligent flight control, Optical flow positioning module, and altitude hold module. With its dual brushless motor drive, it is especially suitable for beginners. It can also serve as an excellent static display model.

Before operating the helicopter, please read this user manual carefully. This manual provides detailed instructions to help you understand the product. Incorrect operation may result in damage to the aircraft model, wasting your valuable time and money.

What in box:

No.	Spare parts	Quantity ¹
1	Color Box	1
2	Blister Packaging	1
3	User Manual	1
4	Helicopter	1
5	Transmitter	1
6	USB Cable	1
7	Battery 1200mAh 7.4V	1
8	Cross Screwdriver/Hex Wrench	4
9	Main Rotor Blade	1
10	Tail Rotor	

Caution:

Our company reserves the right to change all specifications, warranties, and other accompanying documents. Please contact us for the latest product information.

Warning:

Please read the entire user manual before operating the product to familiarize yourself with its functions. Failure to operate the product correctly may result in product damage, personal and property losses, and cause serious injury. This is a complex hobby product that requires careful and sensible operation, as well as some basic mechanical skills. Failure to operate this product responsibly and in a safe manner may result in personal injury, damage to the product, or other property. This product is not intended for use by children without direct adult supervision. This manual contains safety, operational, and maintenance instructions. It is essential to read and follow all instructions and warnings in the manual before assembly or use to ensure proper operation and to avoid damage or serious injury.

Safety Precautions and Warnings:

1. Age Recommendation: Not suitable for children under 14 years old. This is not a toy.
2. Always operate your model in an open space away from vehicles, traffic, and people.
3. Follow operating notices, warnings, and any supporting equipment instructions (charger, batteries, etc.) carefully.
4. Keep away from any chemicals; keep small parts and electrical components away from children.
5. Always stay away from water, especially as this product is not waterproof; it will be damaged by moisture.
6. Do not put any part of the model in your mouth, as it may cause serious injury or even death.
7. Do not operate your model using low-voltage transmitter batteries.

Helicopter Specifications:

Length	352 mm
Height	120 mm
Weight	283 g
Main Rotor Diameter	328 mm
Tail Rotor Diameter	70 mm
Battery Specifications	7.4V 1200mah 25C
Flight Time	8–10 Min
Main Brushless Motor	2507
Brushless Tail Motor	1204

⚠ Warnings and Battery Usage Guide:



For safety purposes, please use the provided standard charger.

⚠ Warning: It is strongly recommended to use the included charger for battery charging.

⚠ Caution: Lithium batteries may be damaged and may not charge properly when the voltage drops below 7.4V.

Battery Charging:

1. Connect the USB cable to a computer USB port or a power adapter.
2. Connect the USB's other end (Type-C plug for Android) to the battery for charging.
3. During charging, the current battery level indicator will flash, and all four lights will remain solid when charging is complete.
4. Disconnect the charging connection after charging is complete.

Note: It is recommended to use a 5V 2A adapter for charging, as it will enable faster charging.

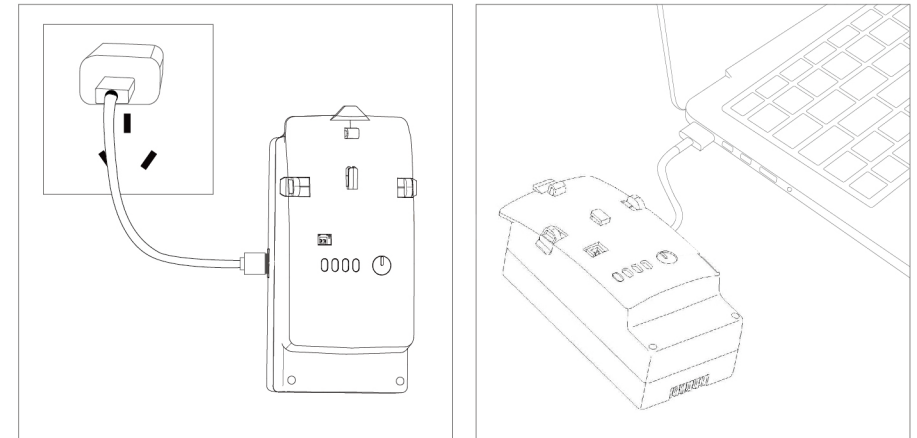

⚠ Warning:

1. To ensure maximum safety, monitor the battery while it is charging.
2. Do not allow children to charge the battery on their own, but ensure that an adult supervises the entire process.

Battery Functions and Indicators:

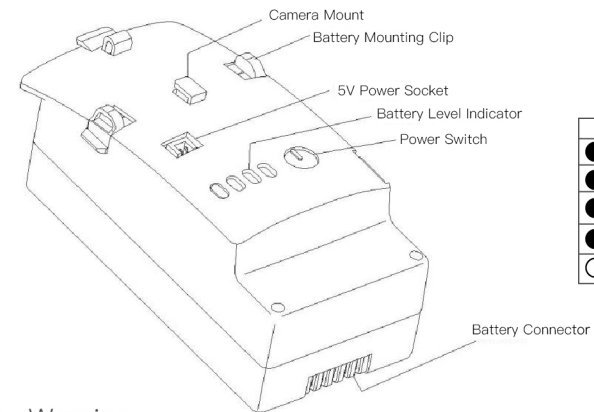

Status:	Power:
●●●●	4 lights on 100%
●●●○	3 lights on 75%
●●○○	2 lights on 50%
●○○○	1 light on 25%
○○○○	4 lights flashing Low Battery

⚠ Warning:

After use, please turn off the battery as prolonged power-on time may shorten the battery lifespan.

After flying, remove the battery from the cabin to prevent damage due to over-discharge.

Transmitter Functions

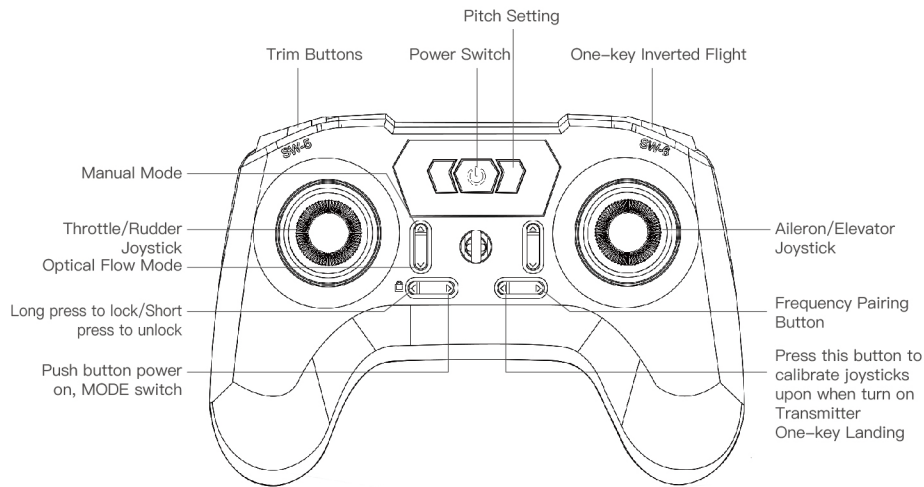

⚠ Caution:

- 1.The default factory setting is MODE2 with left-hand throttle. The remote control's blue light is on. Press the right-side trim button to switch to MODE1, indicated by the remote control's red and blue lights.
- 2.To calibrate the remote control's joysticks, power on the remote control by pressing the left-side trim button. The remote control will emit three beeps. Keep the remote control still and it will automatically calibrate the joysticks.
- 3.The default setting for the trim buttons is small trim. Press the trim buttons to switch between small trim (two beeps) and large trim (one beep).

Right-hand throttle

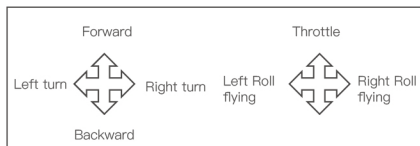

Left-hand throttle

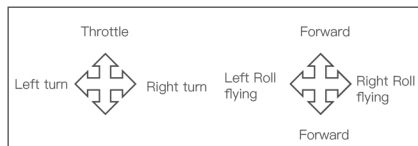

Aircraft and Remote Control Frequency Binding:

When purchasing the aircraft kit, the remote control already bound to the aircraft at the factory and can be used directly. In other cases, please follow the instructions below for binding.

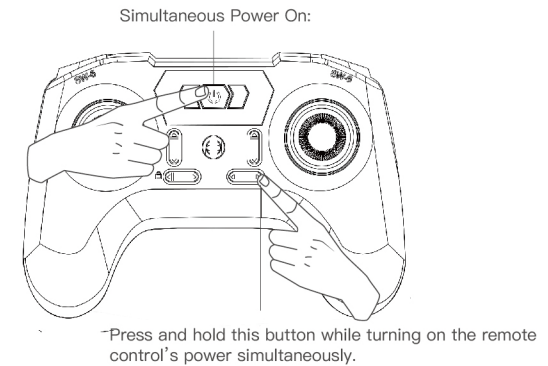

- 1.Press and hold the right-side trim button of the remote control's auxiliary joystick while turning on the remote control to enter binding mode. The remote control will emit a beep sound upon power on, and the remote control's indicator light will flash quickly, indicating it has entered binding mode.
- 2.Power on the aircraft and turn on the battery switch. The aircraft's indicator light will flash yellow.
- 3.Keep the aircraft still within 0.5m from the remote control.
- 4.The remote control will emit two beeps, and the remote control's indicator light will remain solid. At the same time, the aircraft's indicator light will also return to a solid green, indicating successful binding.
- 5.If the binding process is unsuccessful, please repeat the above steps to rebind.

Aircraft Status Indicator Light Explanation:

- 1.Rapid yellow flashing: Aircraft self-checking. The aircraft should remain stationary until the self-check is completed.
- 2.Solid green: Downward visual optical flow mode. Limited to flying at a height of 8 meters.
- 3.Slow green flashing: Poor downward visual environment. Lower the flight altitude or change the flying area.
- 4.Solid red: Manual flight mode. Exercise close attention when flying manually.
5. Slow red flashing: Low-level battery warning. Control the aircraft within visual range.
6. Rapid red flashing: Critical-level battery warning. The aircraft will initiate an automatic landing.

Gyroscope Calibration:

After successful binding between the aircraft and the remote control, perform the following steps to calibrate the gyroscope. On the remote control (MODE2), hold the left joystick in the upper corner and the right joystick in the lower corner as shown in the diagram for 2–3 seconds. During this time, the aircraft's indicator light will flash yellow and then change to solid green, indicating that the calibration is complete.

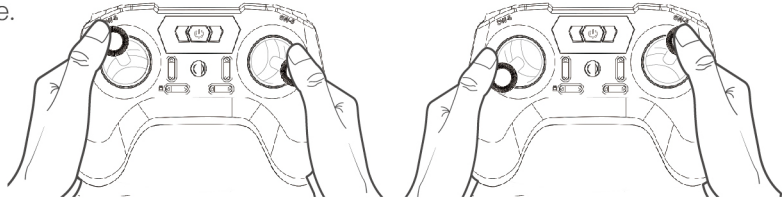

MODE2 (Access gyroscope calibration for Mode 2) MODE1 (Access gyroscope calibration for Mode 1)

During gyroscope calibration, it is important to place the aircraft on a level surface to ensure accurate flight.

The gyroscope is already calibrated at the factory, so users do not need to calibrate it again unless they are unable to exit the initialization or if there is yaw drift in manual attitude mode. In such cases, recalibration is necessary. After successful calibration, the indicator light will provide prompts based on the current position of the remote control's switch, as explained in the indicator light section.

Manual Motor Start/Stop:

Motor Start:

Perform the throttle stick action to start the motor. Immediately release the stick after starting the motor. Push the throttle stick upward by more than 50%, and the aircraft will take off.

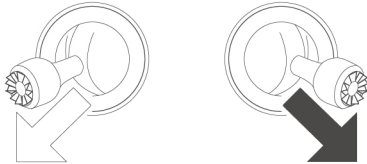

Motor Stop:

There are two methods to stop the motor after it has started:

Method 1: After the aircraft has landed, move the throttle stick to the lowest position and hold it for at least 3 seconds to stop the motor.

Method 2: After the aircraft has landed, pull both joysticks inward simultaneously to stop the motor immediately. Release the sticks after the motor has stopped.

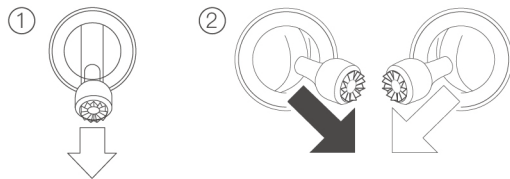

Aircraft Locking:

Long press the lock button to hear two beeps for locking, and short press for one beep to unlock. Locking should not be performed while the aircraft is in the air, as it may cause the motors to stop and pose a risk of crashing.

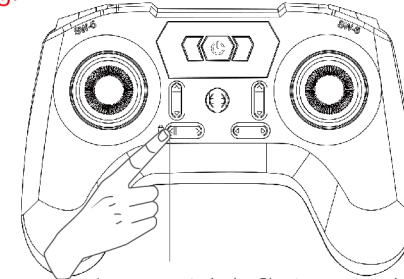

Long press to lock. Short press to unlock.

First Flight:

If you are not familiar with F06, please take a few minutes to familiarize yourself with its controls before attempting your first flight.

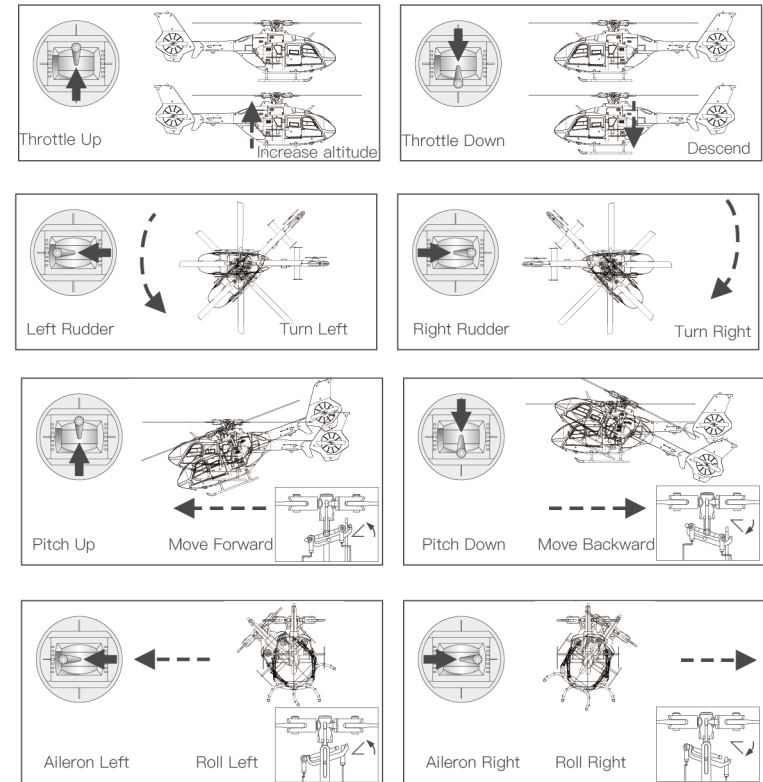

Main Control Board Socket Diagram:

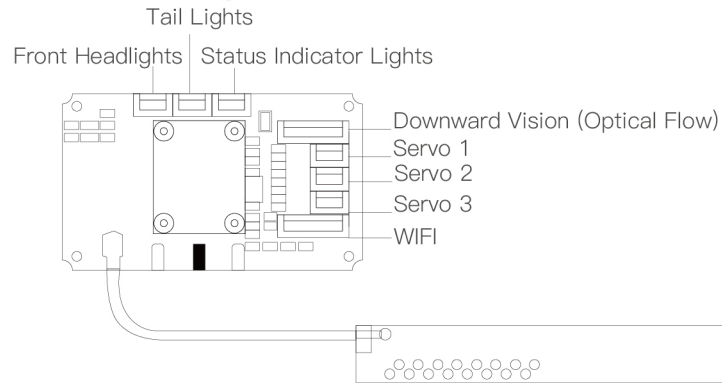

Notes on Downward Vision Mode:

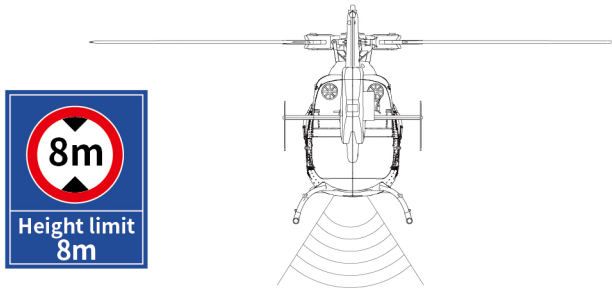

Please pay attention to the surrounding flying environment. The vision system only serves as an auxiliary function under limited conditions. It cannot replace human judgment and control. Users should constantly be aware of the surrounding environment during flight, maintain control over the aircraft throughout the entire flight, and take responsibility for their actions.

The downward vision system relies on the camera to lock onto objects below and limits the takeoff altitude to 8 meters. Please avoid taking off from rooftops or flying over rooftops, as it may cause the downward vision to fail, resulting in aircraft drift. In such cases, immediately fly the aircraft back or switch to manual stability mode.

The downward vision system cannot recognize surfaces without textured features and cannot function properly in environments with insufficient or excessive lighting. The following scenarios are where the downward vision system cannot work:

- 1.Solid color surfaces (e.g., solid black, solid white, solid red, solid green)
- 2.Surfaces with strong reflections or reflections
- 3.Water surfaces or surfaces of transparent objects
- 4.Surfaces of moving objects (e.g., above crowds, bushes, and grasses swaying in strong winds)
- 5.Scenes with rapidly changing lighting conditions
- 6.Surfaces that are exceptionally dark or exceptionally bright
- 7.Surfaces of materials that have strong absorption or reflection of infrared

Manual Mode Flight:

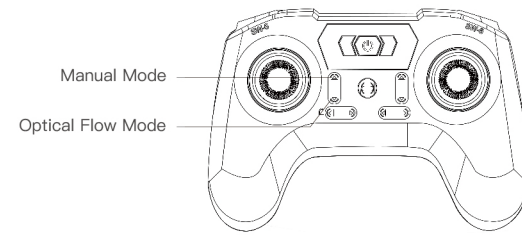

Pressing the Manual Mode button will disable the optical flow flight mode. In this mode, the aircraft's status indicator light will remain solid red, and the altitude restriction will be lifted. The maximum flight speed can reach up to 10 meters per second. Please closely monitor the aircraft and operate with caution. Pressing the throttle adjustment button on the remote control again will activate the optical flow mode, indicated by a solid green status indicator light on the aircraft.

One-Key Landing:

During flight, long-press the One-Key Landing button, and the aircraft will initiate a landing at its current position. While landing, the remote control can still be used to control the aircraft. Pushing the throttle up during the landing process will cancel the landing. Alternatively, pressing the One-Key Landing button again will cancel the one-key landing function.

Expert Inverted Flight Mode:

This mode is designed for 3D aerobatic inverted flight training and should be conducted in open outdoor areas with calm or light wind conditions. In manual mode, with the flight altitude above 9 meters, press the upper right One-Key Inverted Flight button. The remote control will emit two beeps. Quickly push the elevator stick forward or backward and immediately return it to the center position. The aircraft will automatically perform a 180-degree roll and enter inverted flight hover. **In this mode, the helicopter's control input is the same as that of a 3D helicopter (pushing the throttle stick up will make the aircraft descend, pushing the elevator stick forward will make the aircraft move towards the tail).**

Pressing the One-Key Inverted Flight button again and quickly moving the elevator stick will transition the aircraft from inverted flight to normal flight mode, restoring normal flight behavior.

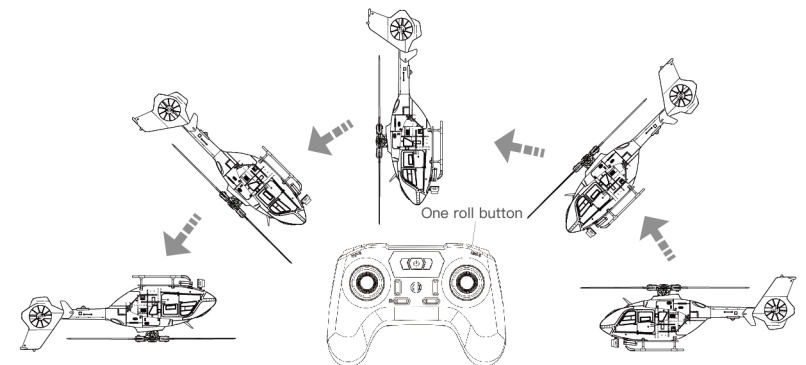

▲ Inverted flight: Forwarder & Backwarder Roll Only. No For Left & Right!

Pitch Setting:

When users replace servos or other major components, it may alter the pitch setting. Correct pitch setting contributes to stable flight. Please follow the steps below for pitch setting.

Long-press for two seconds for pitch setting.

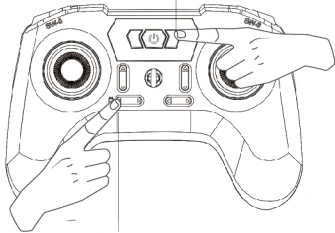

Start by long-pressing the lock button.

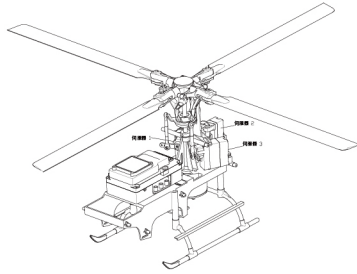

1. Power on the aircraft and bind it with the remote control.
2. Long-press the lock button on the remote control to lock the aircraft with two beeps. Then long-press the pitch setting button to enter pitch setting mode with two beeps.
3. Use the joystick to adjust the corresponding servo until the aircraft's swash-plate is level and the rotor blade angle is 0 degrees. Then, short-press the lock button on the remote control to unlock with a beep, exit the pitch setting mode, and save the settings.

! Note: Pitch setting should be done under the guidance of an experienced individual. Incorrect pitch setting can result in reduced flight performance.

Common Troubleshooting:

No.	Issue	Solution:
1	After powering on, the indicator light keeps flashing rapidly.	The aircraft is in gyroscope self-checking state. Please place the aircraft on a stationary and flat surface.
2	The aircraft tilts to one side and cannot hover after takeoff.	Place the aircraft on a level tabletop or surface and recalibrate the gyroscope.
3	The aircraft experiences severe shaking.	Check for damaged rotor blades and replace them with new ones. Inspect the main shaft and cross-axis for any <u>bending and replace them promptly.</u>
4	The aircraft cannot be unlocked, and the indicator light flashes red rapidly.	The battery voltage is too low. Please fully charge the battery.
5	Unstable flight in strong wind conditions.	Fly in appropriate weather conditions. The aircraft is suitable for flying in wind conditions up to level 4.
6	No response from the helicopter after power on, slow flashing light.	Rebind the frequency. During rebinding, the aircraft should be placed horizontally.
7	Slow flashing green light in downward vision flight mode.	Ground environment may affect the performance of the downward vision system. Please test in a different environment.
8	No power-on sound when connecting power to the helicopter.	The speed controller may be faulty or the plug connection is poor. Replace the speed controller and inspect the plug for timely replacement.
9	Continuous beeping from the remote control during flight.	The aircraft voltage is low, triggering a level 1 alarm. Replace the AAA batteries in the remote control.