

AK700 HELICOPTER

INSTRUCTION MANUAL

STEAM

使用说明书

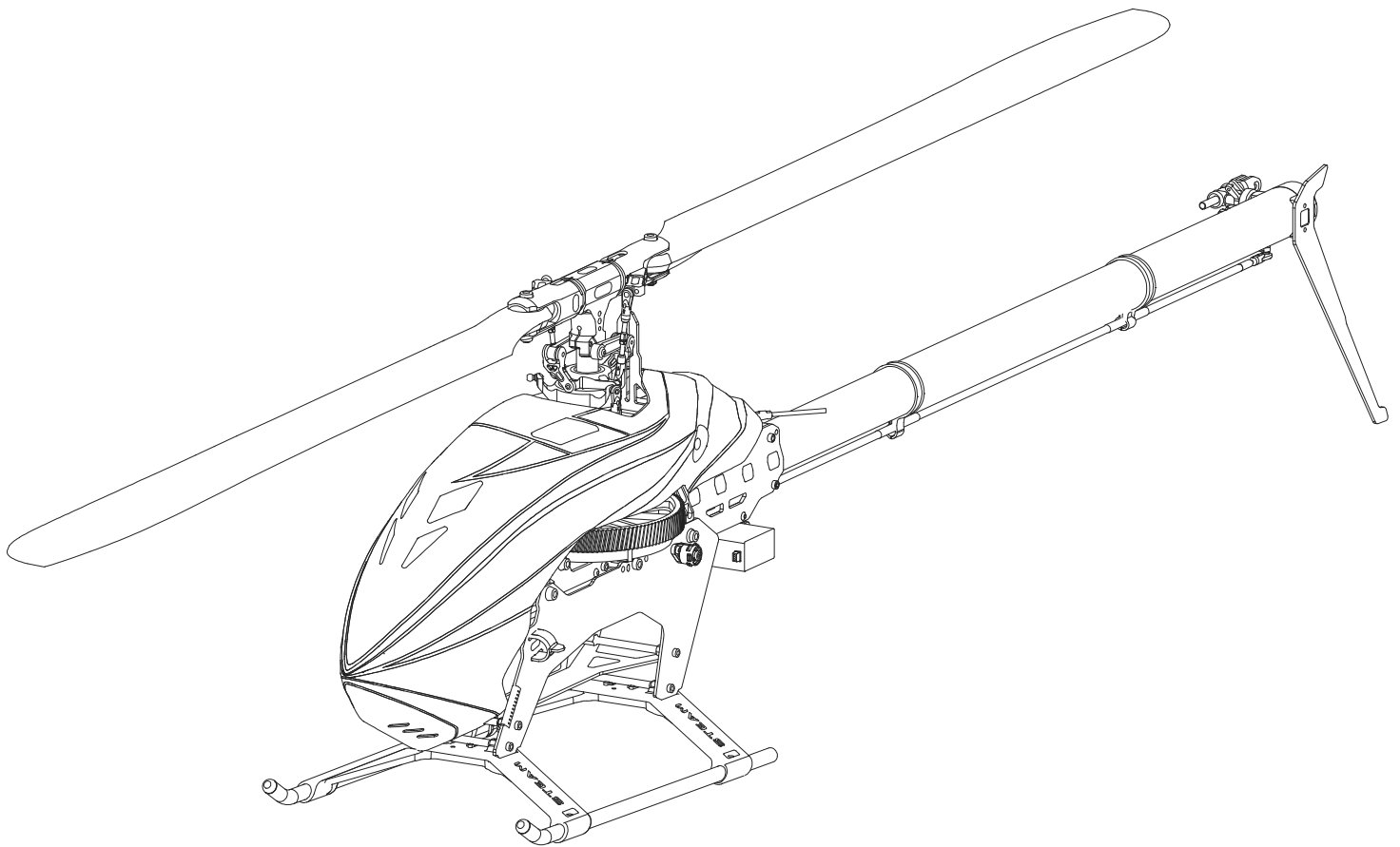

Thank you for buying Steam products. the Steam AK700 helicopter is the latest technology in Rotary RC models. Please read this manual carefully before assembling and flying the new Steam 700 helicopter. We recommend that you keep this manual for future reference regarding tuning and maintenance.

欢迎选购新越科创系列产品。进入遥控世界之前必须告诉您许多相关的知识与注意事项,以确保您能够在学习的过程中较得心应手。在开始操作之前,请务必详阅本说明书,相信一定能够给您带来相当大的帮助也请您妥善保管这本说明书,以作为日后参考。

Thank you for buying STEAM Products . The STEAM Helicopter is designed as an easy to use, full featured Helicopter R/C model capable of all forms of rotary flight . Please read the manual carefully before assembling the model, and follow all precautions and recommendations locate within the manual . Be sure to retain the manual for future reference , routine maintenance, and tuning . The STEAM Helicopter is a new product developed by XinYue.It features the best design available on the Micro-Heli market to date, providing flying stability for beginners , full aerobatic capability for advanced fliers , and unsurpassed reliability for customer support.

感谢您选购STEAM产品, 为了让您容易方便的装配STEAM直升机, 请您参考详细的阅读完这本说明书之后在进行组装以及操作这台直升机, 同时请您妥善的保存这本说明书, 作为日后进行调整以及维修的参考, 不论您是需求飞行稳定性的初学者还是追求性能的飞行爱好者。STEAM 直升机 将是您最佳的选择。

THE MEANING OF SYMBOLS 标志代表含义

 WARNING 警告	Mishandling due to failure to follow these instructions may result in damage or injury. 因为疏忽这些操作说明, 而使用错误可能造成财产损失或严重伤害。
 CAUTION 注意	Mishandling due to failure to follow these instructions may result in danger. 因为疏忽这些操作说明, 而使用错误可能造成危险。
 FORBIDDEN 禁止	Do not attempt under any circumstances. 在任何禁止的环境下, 请勿尝试操作。

IMPORTANT NOTES 重要声明

R/C helicopters, including the STEAM Helicopter are not toys. R/C helicopter utilize various high-tech products and technologies to provide superior performance. Improper use of this product can result in serious injury or even death. Please read this manual carefully before using and make sure to be conscious of your own personal safety and the safety of others and your environment when operating all STEAM products. Manufacturer and seller assume no liability for the operation or the use of this product. This product is intended for use only by adults with experience flying remote control helicopters at a legal flying field. After the sale of this product we cannot maintain any control over its operation or usage.

As the user of this product, you are solely responsible for operating it in a manner that does not endanger yourself and others or result in damage to the product or the property of others STEAM Helicopter

STEAM 遥控直升机并非玩具, 它是结合了许多高科技产品所设计出来的休闲用品, 所以商品的使用不当或不熟悉都可能会造成严重伤害甚至死亡, 使用之前请务必仔细阅读本说明书, 勿忽视并注意自身安全。注意! 任何遥控直升机的使用, 制造商和经销商是无法对使用者于零件使用的损耗异常或者组装不当所发生的意外负任何责任, 本产品是为提供给有操作过模型直升机经验的成人或有相当技术的人员在旁指导于当地合法遥控飞行场飞行, 以确保安全无误下操作使用, 产品出售后本公司将不负任何操作和使用控制上的任何性能与安全责任。

作为本产品的使用者, 您, 是唯一对对您自己操作的环境及行为负全部的责任的人。

we recommend that you obtain the assistance of an experienced pilot before attempting to fly our products for the first time. A local expert is the best way to properly assemble, setup, and fly your model for the first time. Any damage or dissatisfaction as a result of accidents or modifications are not covered by any warranty and cannot be returned for repair or replacement. Please contact our distributors for free technical consultation and parts at discounted rates when you experience problems during operation or maintenance. As STEAM Corporation Limited has no control over use, setup, final assembly, modification or misuse, no liability shall be assumed nor accepted for any resulting damage or injury. By the act of use, setup or assembly, the user accepts all resulting liability

模型商品属于需要较高操作技术且为消耗性的商品, 如果拆装使用后, 会造成不等情况的零件损耗, 任何使用情况所造成商品不良或不满意, 将无法于保固条件内更换新品或退货。对使用者的不当使用、设定、组装、修改、或操作不良所造成的破损或危害, 本公司无法控制及负责。任何使用、设定、组装、修改或操作不良所造成的破损、意外或伤害, 使用者应承担全部责任。

AK700 ISAFETY NOTES



Fly only in safe areas, away from other people, Do not operate R/C aircraft within the vicinity of homes or crowds of people. R/C aircraft are prone to accidents, failures, and crashes due to a variety of reasons including, lack of maintenance, pilot error, and radio interference. Pilots are responsible for their actions and damage or injury occurring during the operation or as a result of R/C aircraft models.

Prior to every flight, carefully check rotorhead spindle shaft screws and tail blade grip screws, linkage balls and screws, ensure they are firmly secured.

遥控模型飞机、直升机属于高危性商品, 飞行时务必远离人群, 人为组装不当或零件损坏、电子控制设备不良, 以及操作上的不熟悉、都可能导致飞行失控损伤等不可预期的意外, 请操作者务必注意飞行安全, 并需了解由自己疏忽所造成的任何意外的责任。

每趟飞行前仔细检查, 主旋翼夹座横轴螺丝、尾旋翼夹座螺丝、以及机身各个部位球头、螺丝, 确保上胶锁紧才能升空飞行。

**LOCATE AN APPROPRIATE LOCATION 远离障碍物以及人群**

R/C helicopters fly at high speed, thus posing a certain degree of potential danger. Choose a legal flying field consisting of flat, smooth ground without obstacles. Do not fly near buildings, high voltage cables, or trees to ensure the safety of yourself, others and your model. For the first practice, please choose a legal flying field. Do not fly your model in inclement weather, such as rain, wind, snow or darkness.

直升机飞行时具有一定的速度，相对的也潜在着危险性，场地的选择也相对的重要，请需遵守当地法规到合法遥控飞行场地飞行。务必选择在空旷合法专属飞行场地，必须注意周围有没有人、高楼、建筑物、高压电线、树木等等，避免操控的不当造成自己与他人的财产损坏。请勿在下雨、打雷等恶劣天气下操作，以确保本身及机体的安全。

**NOTE ON LITHIUM POLYMER BATTERIES 锂聚电池注意事项**

Lithium Polymer batteries are significantly more volatile than alkaline or Ni-Cd/Ni-MH batteries used in RC applications. All manufacturer's instructions and warnings must be followed closely. Mishandling of Li-Po batteries can result in fire. Always follow the manufacturer's instructions when disposing of Lithium Polymer batteries.

锂聚合电池跟一般在RC使用的碱性电池、镍镉电池、镍氢电池比较起来是相对危险的。请严格遵守锂聚合电池说明书的使用注意事项。不恰当使用锂聚合电池，可能会造成火灾并危及生命财产安全，切勿大意！

**PREVENT MOISTURE 远离潮湿环境**

RC models are composed of many precision electrical components. It is critical to keep the model and associated equipment away from moisture and other contaminants. The introduction or exposure to water or moisture in any form can cause the model to malfunction resulting in loss of use, or a crash. Do not operate or expose to rain or moisture.

直升机内部是由许多精密的电子元件组成，所以必须绝对的防治潮湿或者水汽，避免在浴室或者雨天时使用，防止水汽进入机身内部导致机体及电子元件故障而引发的不可预期的意外。

**PROPER OPERATION 勿不当使用本产品**

Please use the replacement of parts on the manual to ensure the safety of instructors. product is for R/C model, so do not use for other purpose.

请勿自行改造加工，任何的升级改造或维修，请使用温州新越产品目录中的零件，以确保结构的安全。请确认在产品接线中操作，请勿过载使用，并勿在俺安全，法令外其它非法用途。

**OBTAIN THE ASSISTANCE OF AN EXPERIENCED PILOT 避免独自操控**

Before turning on your model and transmitter, check to make sure no one else is operating on the same frequency. Frequency interference can cause your model, or other models to crash. The guidance provided by an experienced pilot will be invaluable for the assembly, tuning, trimming, and actual first flight or unforeseen danger may happen. (Recommend you to practice with computer-based flight simulator.)

在飞机起飞前，需确认是否有相同频率的玩家正在进行飞行，因为开启相同频率的发射器将会导致自己与他人立即干扰等意外危险。遥控飞机操控技巧在学习初期就有一定的难度，要尽量避免独自操作飞行，需有经验的人士在旁边指导，才可以操控飞行。（勤练电脑模拟器及老手指导时入门的必要选择）

**SAFE OPERATION 安全操作**

Operate this unit within your ability. Do not fly under tired condition and improper operation may cause in danger. Never take your eyes off the model or leave it unattended while it is turned on. Immediately turn off the model and transmitter when you have landed the model.

请于自己能力内及需要一定技术范围内操作这台直升机，过于疲劳、精神不佳或不当操作，可能会提高发生意外的风险。不可再规定的范围外进行，降落后也请立即关掉直升机与遥控器的电源。

**ALWAYS BE AWARE OF THE ROTATING BLADES 远离运转中的零件**

During the operation of the helicopter, the main rotor and tail rotor will be spinning at high rate of speed. The blades are capable of inflicting serious bodily injury and damage the environment. Be conscious of your actions, and careful to keep your face, eyes, hands, and loose clothing away from the blades. Always fly the model a safe distance from yourself and others, as well as surrounding objects. Never take your eyes off the model or leave unattended while it is turned on. Immediately turn off the model and transmitter when you have landed the model.

当直升机主旋翼与尾旋翼高速旋转时，请勿触摸并保持安全距离以免造成危险及损坏，否则会造成自己与他人身体上或环境上的严重损伤。

**KEEP AWAY FROM HEAT 远离热源**

R/C models are made up various forms of plastic. Plastic is very susceptible to damage deformation due to extreme heat and cold climate. Make sure not to store the model near any source of heat such as an oven, or heater. It is best to store the model indoors, in climate-controlled, room temperature environment.

遥控飞机多半是以PA碳纤或聚乙烯、电子商品为材质，因为要尽量远离热源、日晒，以避免因高温而变甚至熔毁损坏的可能。

CAREFULLY INSPECT BEFORE REAL FLIGHT 请严格执行飞行前的检查义务

- Before flying, please check to make sure no one else is operating on the same frequency for the safety.
- Before flight, please check if the batteries of transmitter and receiver are enough for the flight.
- Before turn on the transmitter, please check if the throttle stick is in the lowest position. IDLE switch is OFF.
- When turn off the unit, please follow the power on/off procedure. Power ON- Please turn on the transmitter first, and then turn on receiver. Power OFF- Please turn off the receiver first and then turn off the transmitter. Improper procedure may cause out of control, so please to have this correct habit
- Before operation, check every movement is smooth and directions are correct. Carefully inspect servos for interference and broken gear.
- Check for missing or loose screws and nuts. See if there is any cracked and incomplete assembly of parts. Carefully check main rotor blades and rotor holders. Broken and premature failures of parts possibly cause a dangerous situation.
- Check all ball links to avoid excess play and replace as needed. Failure to do so will result in poor flight stability.
- Check if the battery and power plug are fastened. Vibration and violent flight may cause the plug loose and result in out of control.
- 每次飞行前应先确定所使用的频率是否会干扰他人，以确保您自身与他人的安全。
- 每次飞行前应先确定您发射器与接收器电池的电量是足够飞行的状态。
- 开机前确认油门摇杆是最低点，熄火降落开关，定速开关(IDLE)是否于关闭位置。
- 关机时必须遵守电源开关机的程序，开机时应先开启发射器后，再开启接收器电源；关机时先关闭接收器后，再关闭发射器电源。不正确的开关程序可能会造成失控的现象，影响自身与他人的安全，请养成正确的习惯。
- 开机请先确定直升机的各动作是否顺畅，及方向是否正确，并且检测舵机的动作是有否右干涉或扫齿的情形，使用故障的舵机将导致不可预期的危险。
- 飞行前确认没有缺少或松脱螺丝与螺帽，确认没有组装不完整或损失毁灭性的零件，仔细检查主旋翼是有否损坏，特别是接近主旋翼夹座的部位。损坏或组装不完整不仅影响飞行，更会造成不可预期的危险。注意：每次飞行前的安全检查、保养、及更换损耗零件，请严格执行以确保安全。
- 检查所有的连杆头是否有松脱的情形，过松的连杆头应先更换，否则将造成直升机无法操控的危险。
- 确认电池及电源接头是否固定牢靠，飞行中的震动或激烈的飞行，可能造成电源头松脱而造成失控的危险。

AK700 EQUIPMENT REQUIRED FOR ASSEMBLY

STEAM

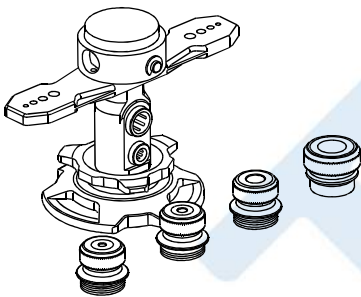
ADDITIONAL TOOLS REQUIRED FOR ASSEMBLY**自备工具**

Machine Adjustment Tool Set
调机工具套装/HOT100000

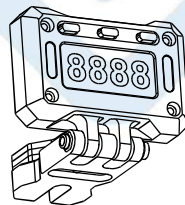

Electronic Pitch Gauge
电子螺距尺/HOT100019

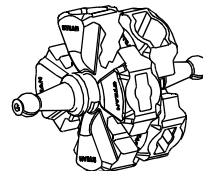

Ball Head Knife Set
球头刀套装/HZ037

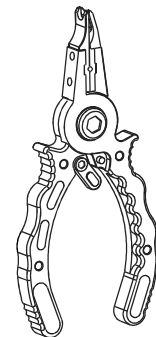

Ball nose pliers
球头钳/HZ085

680: Apply small amount of Bearing Glue to fix (Additional)
轴承胶/K10291C: 使用适量轴承胶固定(另购件)

OIL: ADD small amount of OIL (Additional)
锂基脂/HOT00009: 使用适量锂基脂(另购件)

271: Apply small amount of Screw Glue to fix (Additional)
螺丝胶/K10291A: 使用适量螺丝胶(另购件)

Grease: ADD small amount of Grease (Additional)
橡胶润滑脂/HOT00006: 使用适量橡胶润滑脂(另购件)

When you see the marks as below, please use relative glue or grease to ensure flying safety.
标有以下符号的组装步骤，请配合上胶或上油，以确保锁紧零件使用的可靠度。

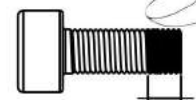

271 Glue width: approx. 4mm

271上胶宽度约4mm

Apply a little amount of 271 thread lock when fixing a metal part.
所有螺丝锁紧金属件时请使用适量 271 (螺丝胶)



For original manufactory package, if the product is already assembled by factory, please check again if screws are firmly secured and applied with some glue.
原装零件出厂包装如果组装完毕, 请需再确认各螺丝是否锁紧上胶。

X1 Accessory Package:

- Bearing(Ø10xØ19x7mm) x2
- Main Rotor Holderx2
- Thrust Bearing(Ø10xØ19x6mm) x2
- Spindle Bearing Spacer(Ø10xØ14x1mm) x2
- Bearing(Ø10xØ19x7mm) x2
- Main Rotor Holder Arm x2
- Socket Screw(M3x6mm) x4

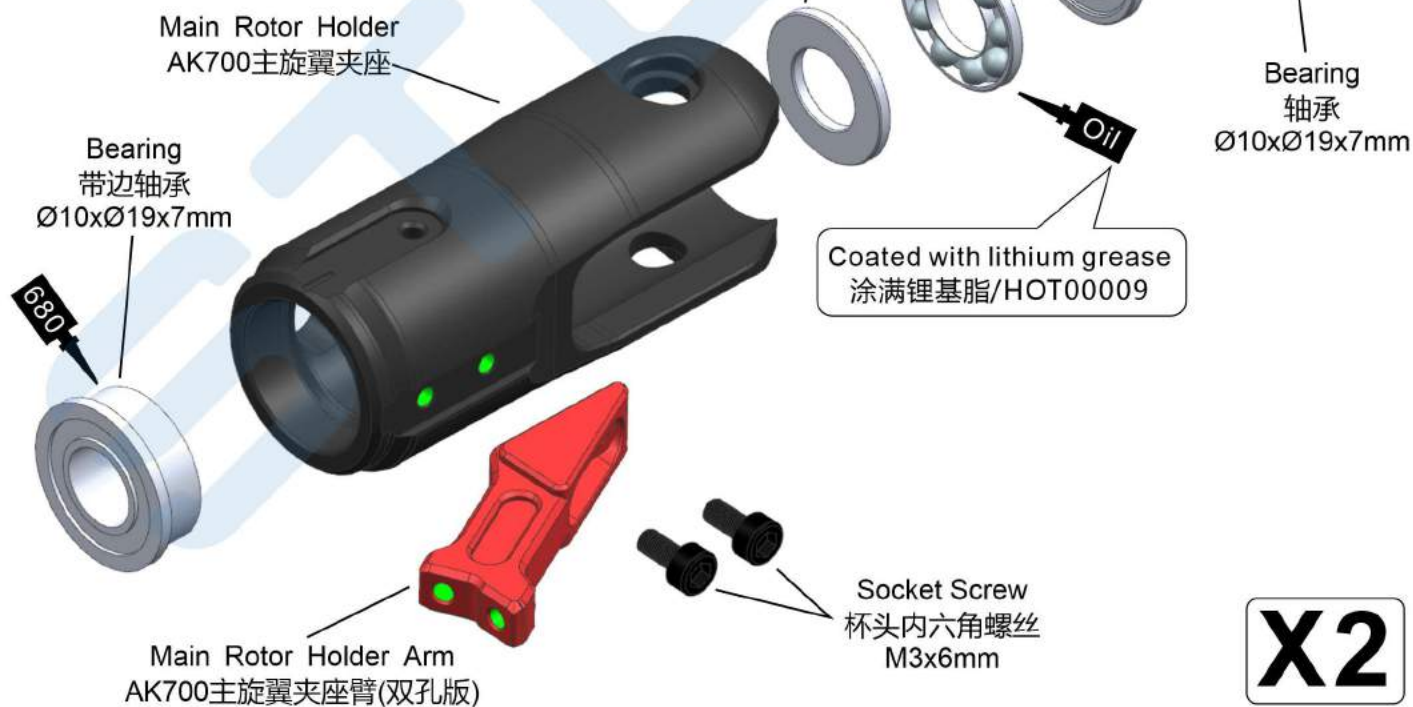
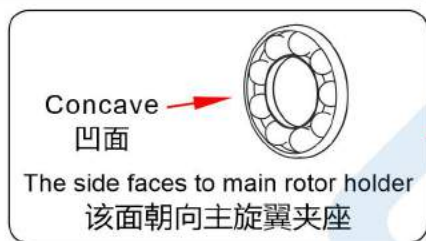
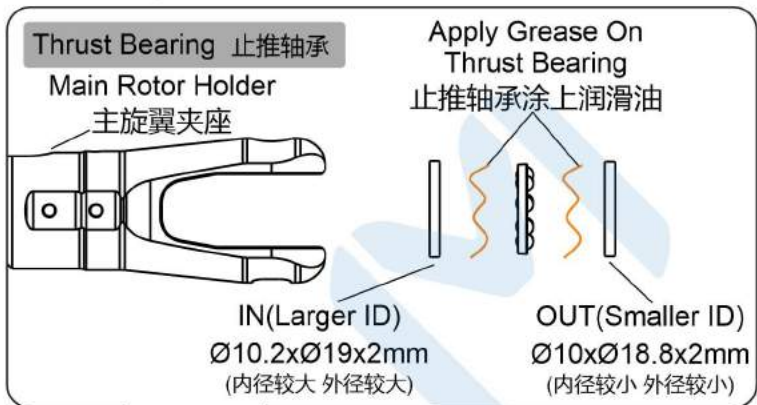
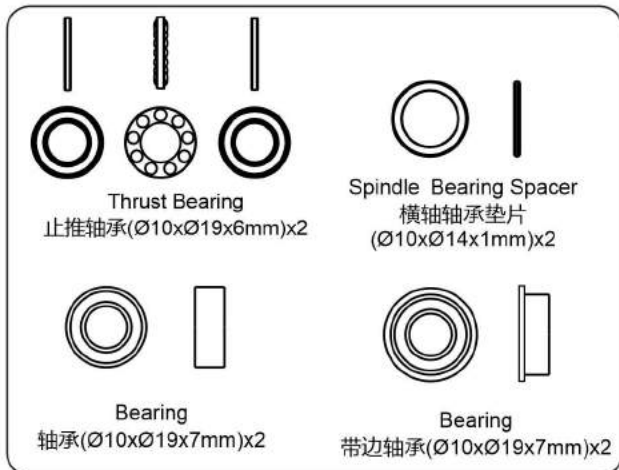

X2

Thrust bearing and washer for radial bearing are wear items , and thus should be inspected for replacement after every 20 flights. For flights with high headspeed , the inspection interval should be reduced to ensure flight safety.
止推轴承及横轴垫圈属于飞行消耗品,建议20趟定期检查及更换,高主旋翼转速飞行时,请缩短定期检查之趟数,以确保飞行安全。

		
Damper rubber 横轴橡胶垫圈 Ø12.8xØ19x3.1mmx4	Spindle Bearing Spacer 横轴轴承垫片 Ø10xØ16x1.3mmx2	Spindle Bearing Spacer 横轴轴承垫片 Ø6.5xØ16x2mmx2

X1 Accessory Package:
 Main Rotor Housing x1
 Feathering Shaft x1
 Feathering Shaft Rubber Washer (Ø10XØ15.5X3mm) x2
 Feathering Shaft Bearing (Ø10xØ16x1.3mm) x2
 Feathering Shaft Bearing (Ø6xØ13x0.5mm) x2
 Socket Screw (M6x12mm) x2



After the T part is installed, check the symmetry.
零件安装完成后,检查对称性。

Apply full rubber grease
涂满橡胶润滑脂/HOT00006

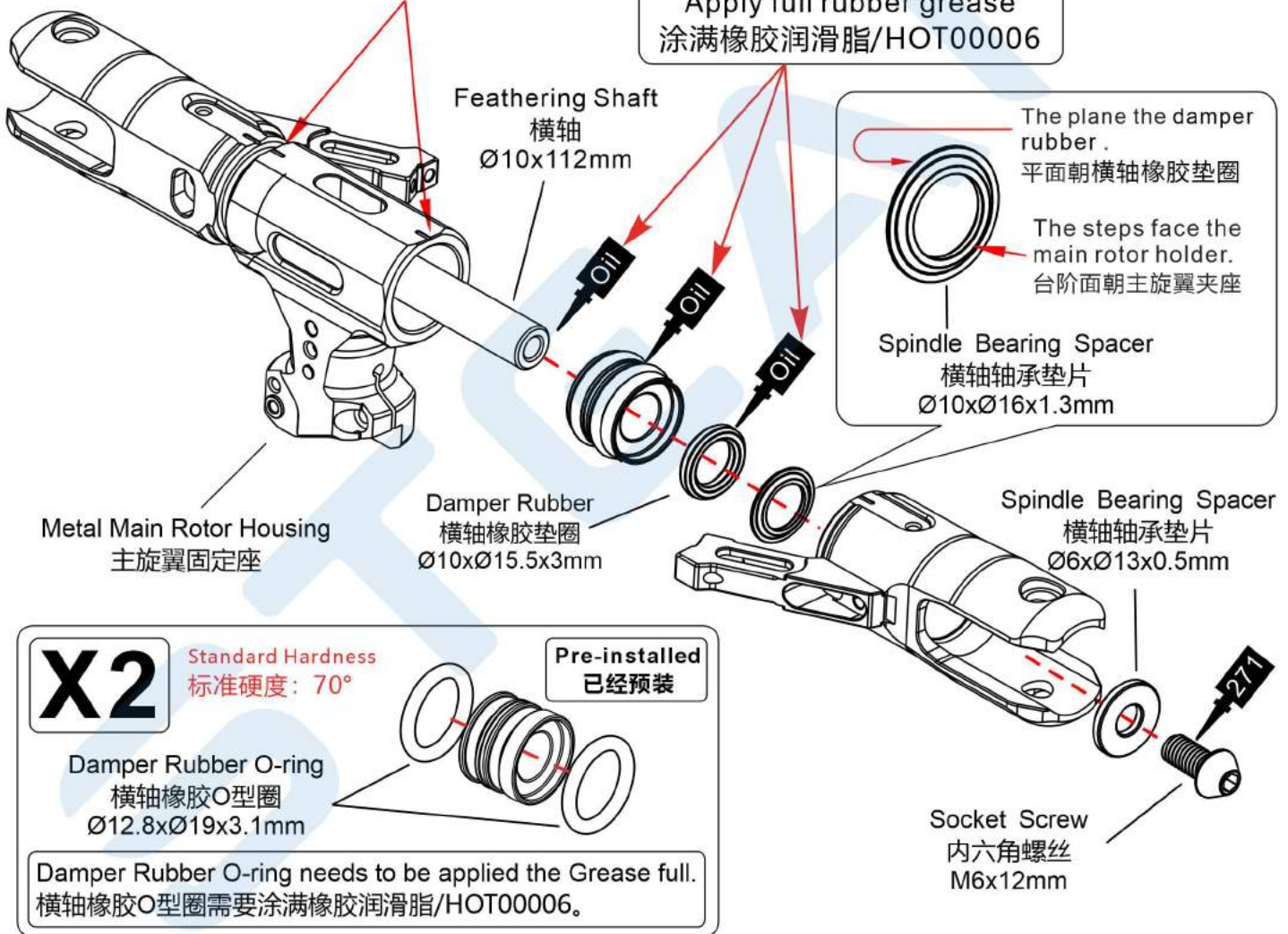

Damper Rubber O-ring needs to be applied the Grease full.
横轴橡胶O型圈需要涂满橡胶润滑脂/HOT00006。

Apply a little amount of 271 thread lock when fixing a metal part.
所有螺丝锁紧金属件时请使用适量 271 (螺丝胶)
横轴涂胶量需要一半以上螺纹

The feathering shaft and feathering shaft socket screws are wear items , and thus should be inspected for replacement after every 20 flights. For flights with high head speed , the inspection interval should be reduced to ensure flight safety.
主旋翼轴承、横轴和横轴螺丝属于飞行消耗品, 建议每 20 趟定期检查以及更换. 主轴旋转飞速时, 请缩短定期检查趟数, 以确保飞行安全 .

For original manufactory package, if the product is already assembled by factory, please check again if screws are firmly secured and applied with some glue.
 原装零件出厂包装如果组装完毕, 请需再确认各螺丝是否锁紧上胶.



Apply a little amount of 271 thread lock when fixing a metal part.
 所有螺丝锁紧金属件时请使用适量 271 (螺丝胶)

X1 Accessory Package:

- Bearing (Ø3xØ7x3mm) x4
- Control Arm x2
- Radius Arm x2
- Shaft x2
- Socket Screw (M2x4mm) x2
- Socket Screw (M3x10mm) x2
- Spacer(Ø3xØ5x0.7mm)x2

31mm(Orange) Expert Player (10%)
 31mm(橙色) 极限玩家 (10%)
 32.5mm(Red) Amateur Player (90%)
 32.5mm(红色) 普通玩家 (90%)

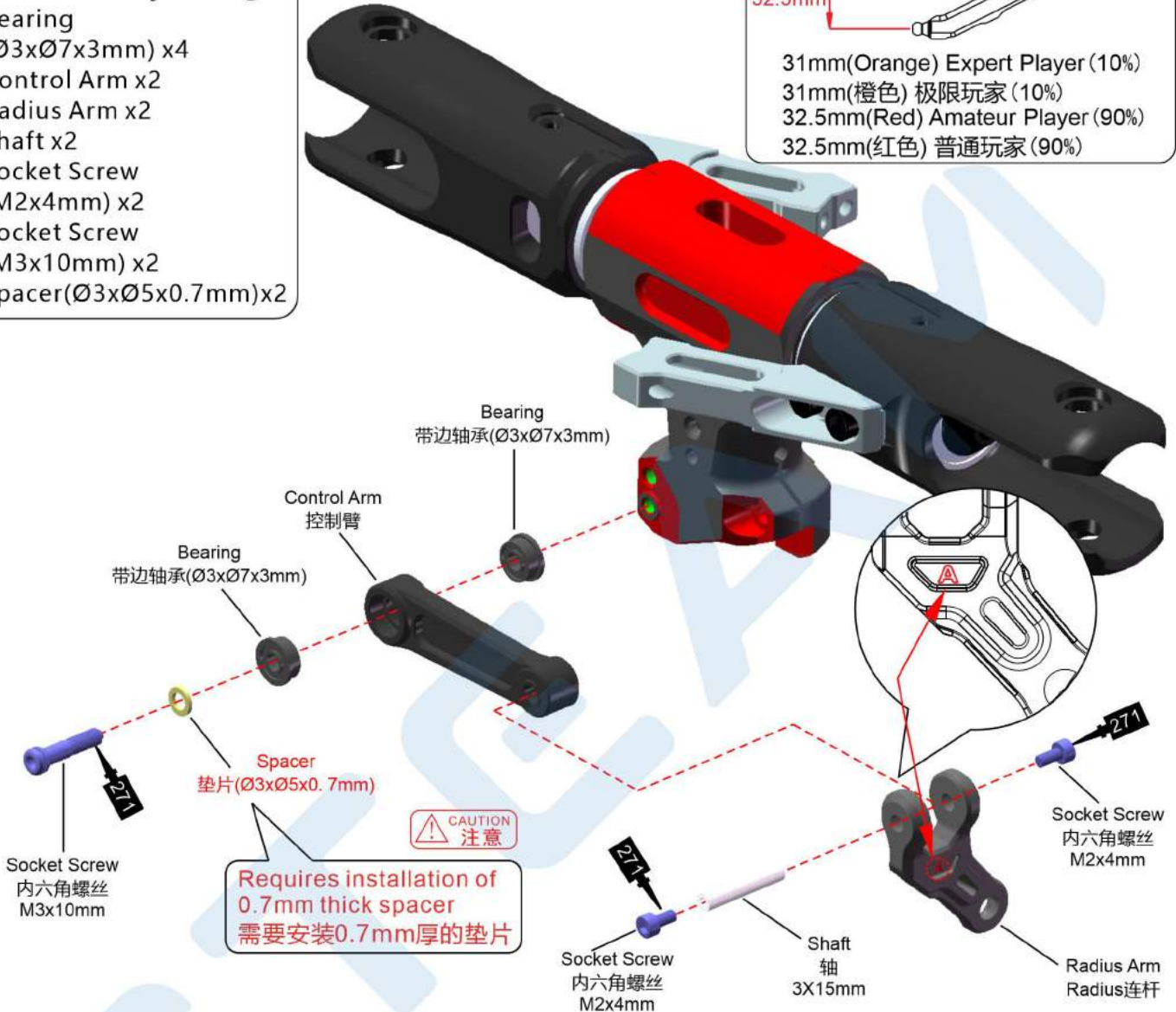

Linkage Ball B (M3x4)
 球头(Ø5x10.3mm)

X2 Accessory Package:

- Swashplate Group x1
- Linkage Ball (Ø5x10.3mm) x6
- Long Linkage ball (Ø5.8x31.8mm) x1

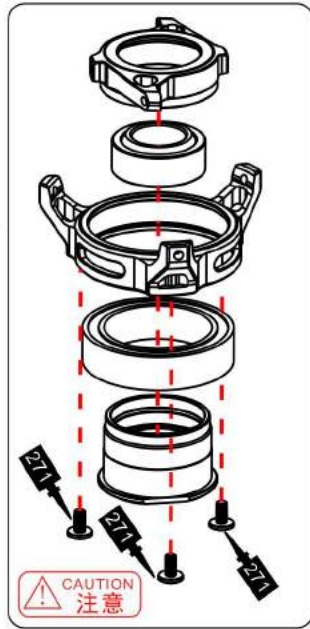
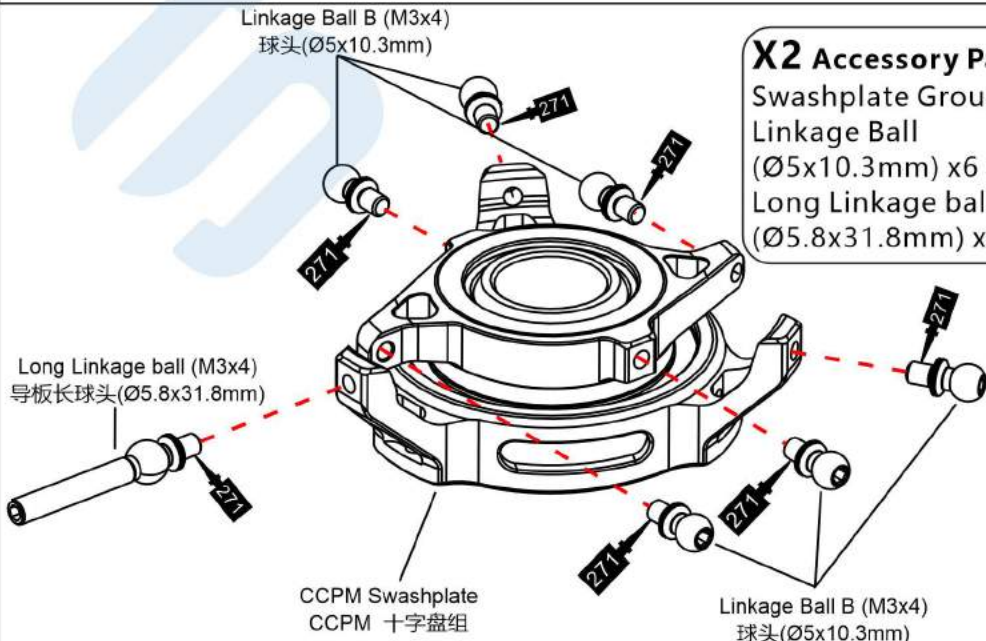

For original manufactory package, if the product is already assembled by factory, please check again if screws are firmly secured and applied with some glue.
 原装零件出厂包装如果组装完毕, 请需再确认各螺丝是否锁紧上胶。



31mm(Orange) Expert Player (10%)
 31mm(橙色) 极限玩家 (10%)
 32.5mm(Red) Amateur Player (90%)
 32.5mm(红色) 普通玩家 (90%)

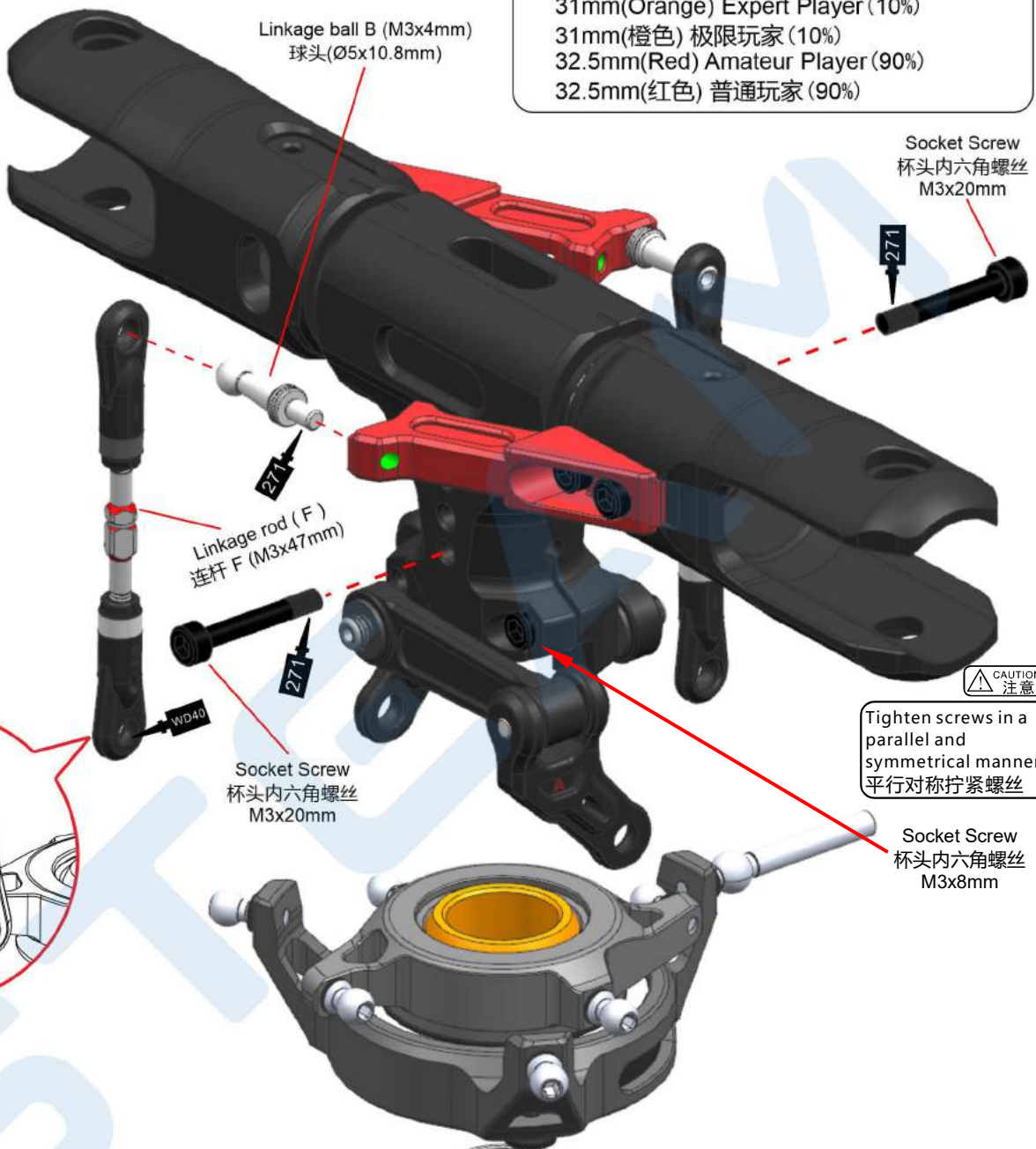

Tighten screws in a parallel and symmetrical manner
 平行对称拧紧螺丝



The daily maintenance of the spindle matters needing attention:
 1. It needs to be placed vertically.
 2. Use anti-rust oil when not in use.
 主轴的日常保养维护注意事项:
 1. 需要垂直放置。
 2. 不用的时候需要抹上防锈油。

1. Main rotor head and main shaft washer are wear items; it is recommended to inspect after every 20 flights and replace as necessary. For high head speed flight, the inspection interval should be reduced to ensure flight safety.
 2. Make sure to check and change the parts if any failure due to normal deterioration or mechanical wear to prevent expected danger during high head speed flight.
 1. 旋翼头组及主轴属于飞行消耗品, 建议每 20 趟定期检查及更换, 请缩短定期检查之趟数, 以确保飞行安全。
 2. 若发生人为组装不当或者零件损毁造成模型商品摔机时, 请务必仔细检查损坏的部件且强烈推荐将其更换, 避免主旋翼告诉飞行时发生无法预期的意外。

X3 Accessory Package:
 Linkage Rod(F) (M3x47mm) x3
 Linkage Ball (Ø5x10.8mm) x2
 Socket Screw (M3x20mm) x2
 Socket Screw (M3x8mm) x2
 Main Shaft x1

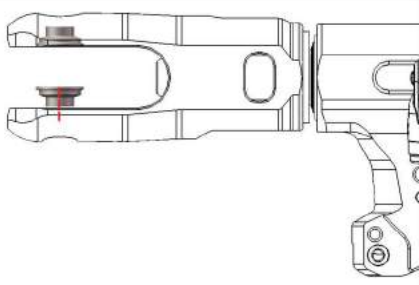

For blade thicknesses of 14 mm, only stainless steel washers should be installed.

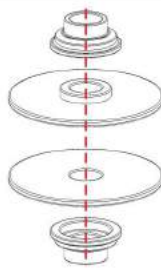

Stainless steel washers and red gaskets can be separated.

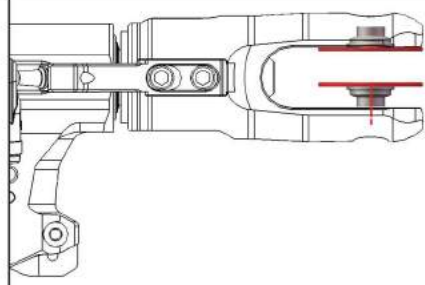

For blade thicknesses of 12 mm, it is necessary to install stainless steel washer and red spacer.

CAUTION 注意 Stainless steel washer: must be installed.
CAUTION 注意 Red spacer: choose whether to install or not according to the thickness of blade.
CAUTION 注意

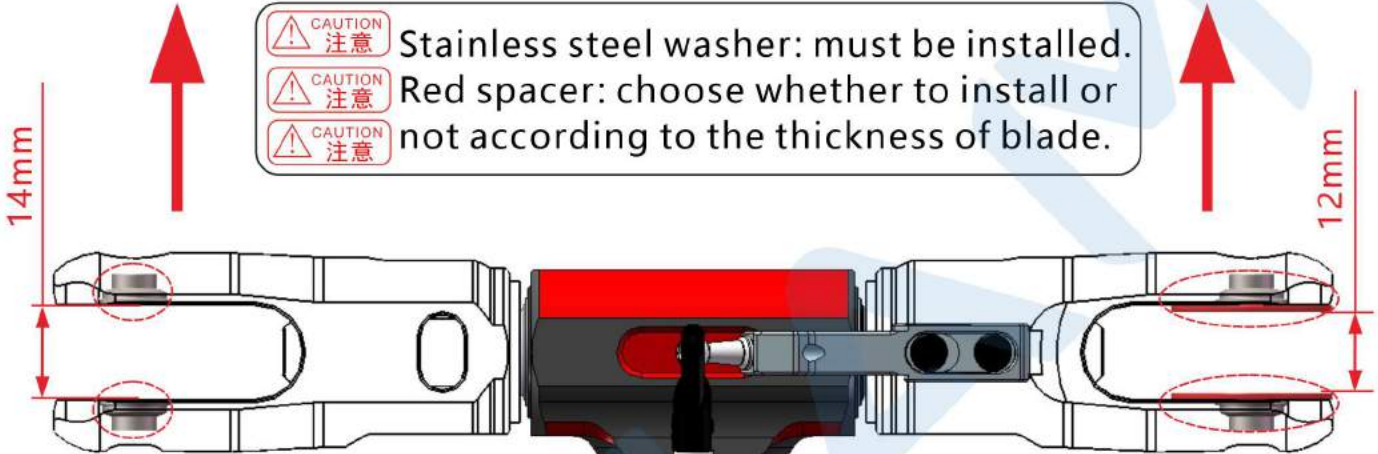

Linkage Rod (F)
 Approx. 63.8 (31mm) / 64mm (34mm) x2
 连杆(F)约63.8 (31mm) / 64mm (34mm) x2

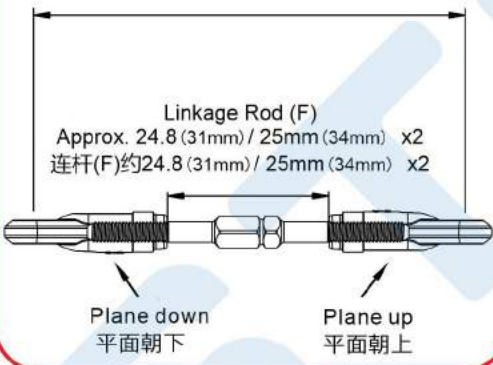

The distance between swashplate and main shaft fixed ring is 23.30mm, which is used as the reference parameter of the whole set of rotor head.

CAUTION 注意

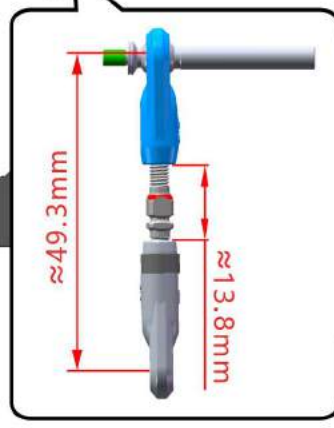

Carbon Fiber Wrench

Flat Head Socket Screw
M3x6mm

Button Head Screw
M3x6mm

A1 Accessory Package:

- Front Structural Plate x1
- Hexagonal Aluminum Column x2
- Flat Head Socket Screw (M3x6mm) x4
- Button Head Screw (M3x6mm) x2

B1 Accessory Package:

- Upper Side Panel x2
- Lower Side Panel x2

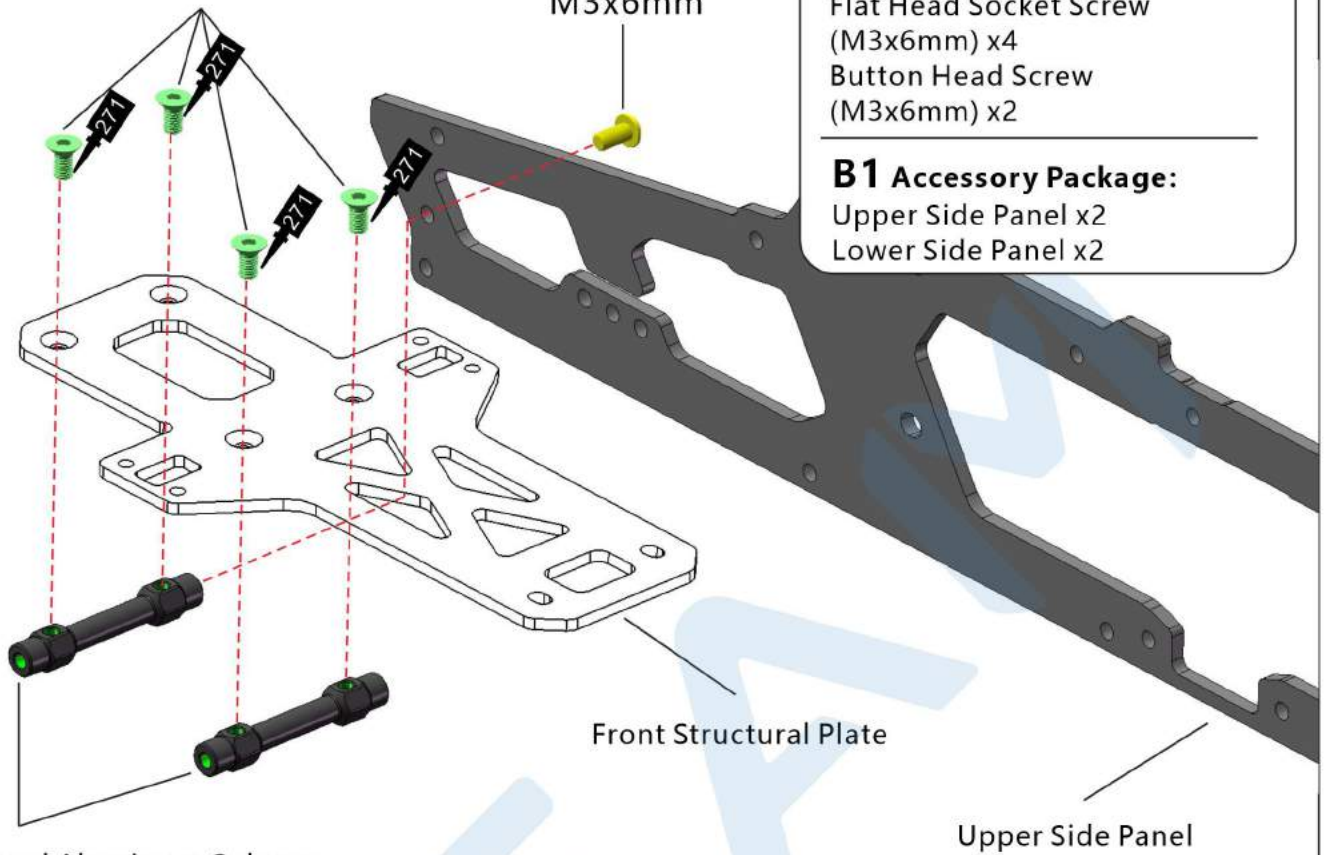

Hexagonal Aluminum Column

Front Structural Plate

Upper Side Panel

A2 Accessory Package:

- Second Bearing Housing x1
- Ball Screw (M4x5mm) x1
- Socket Screw (M3x7mm) x6

Socket Screw
M3x7mm

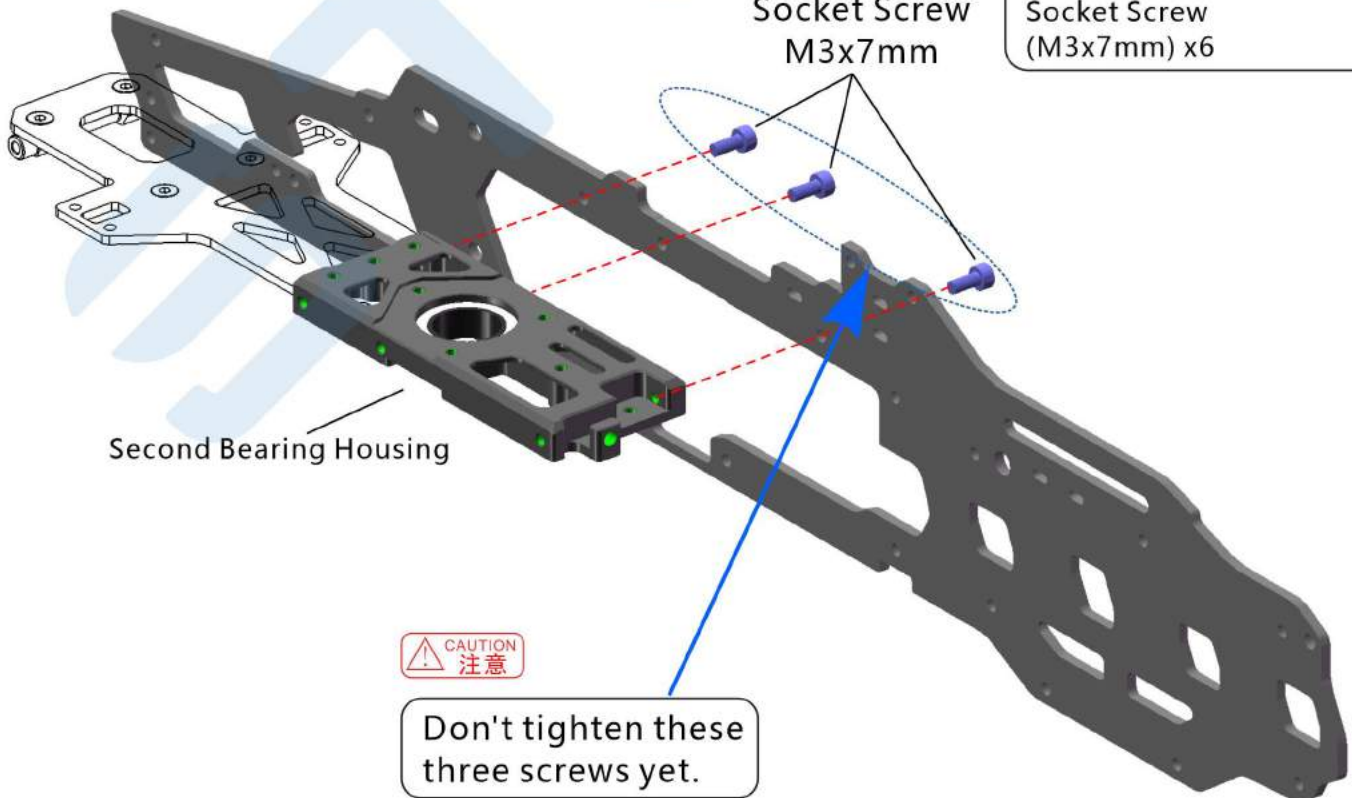

Second Bearing Housing



Don't tighten these three screws yet.

A3 Accessory Package:

- Third Bearing Housing x1
- Flat Head Socket Screw (M3x6mm) x4
- Rear Structural Plate x1
- Hexagonal Aluminum Column x1
- Socket Screw (M3x7mm) x4

Don't tighten these two screws yet.



Socket Screw
M3x7mm

Third Bearing Housing

Flat Head Socket Screw
M3x6mm

Rear Structural Plate

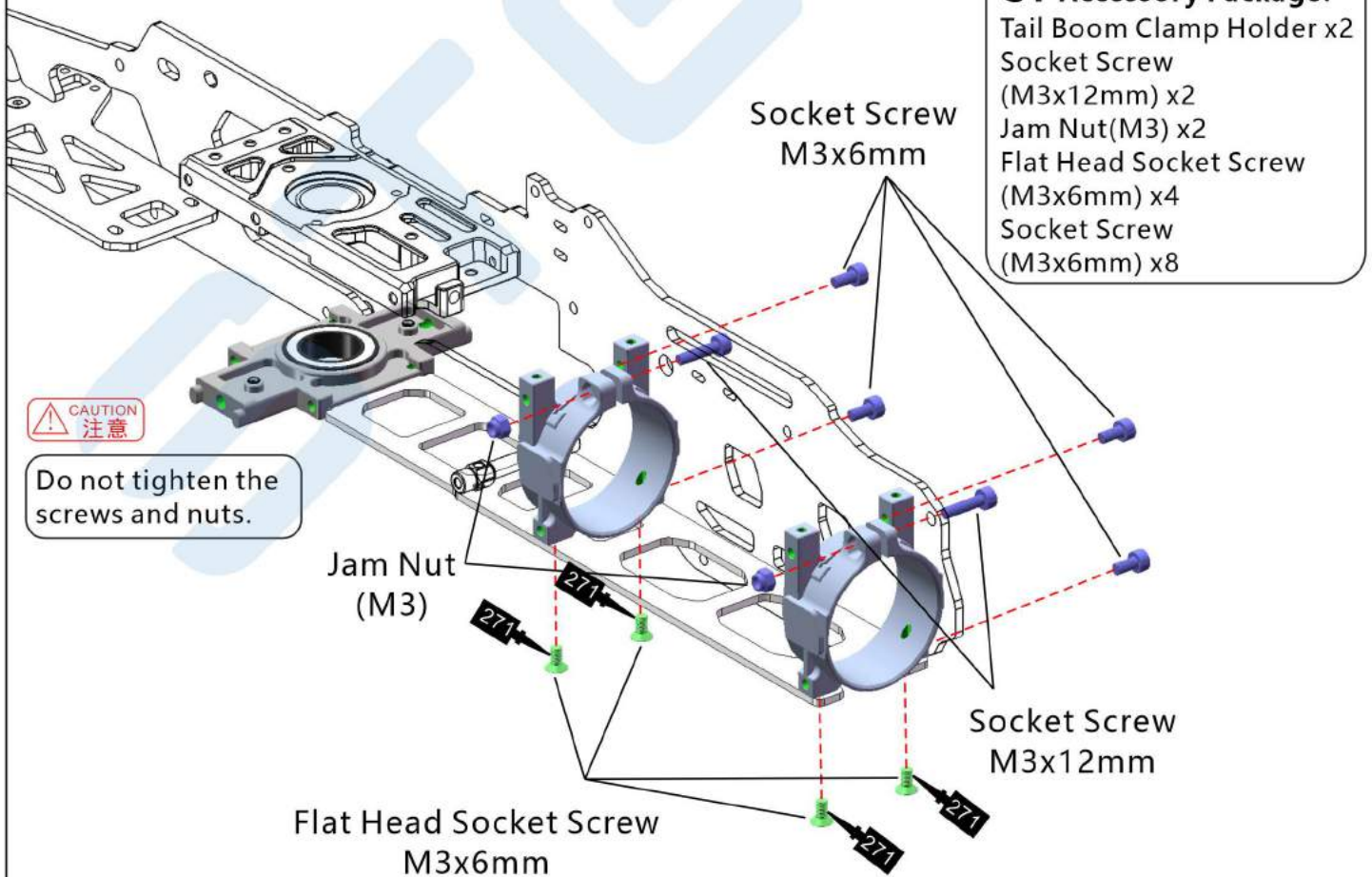

C1 Accessory Package:

- Tail Boom Clamp Holder x2
- Socket Screw (M3x12mm) x2
- Jam Nut (M3) x2
- Flat Head Socket Screw (M3x6mm) x4
- Socket Screw (M3x6mm) x8

Socket Screw
M3x6mm



Do not tighten the screws and nuts.

Jam Nut
(M3)

Socket Screw
M3x12mm

Flat Head Socket Screw
M3x6mm

A4 Accessory Package:

- Electronics Service Board x1
- Socket Screw (M3x5mm) x1
- Spacer(M3)x1
- Flat Head Socket Screw (M3x6mm) x8
- Antenna Mount Group x1

Spacer(M3)
Socket Screw M3x5mm
Flat Head Socket Screw M3x6mm

Electronics Service Board

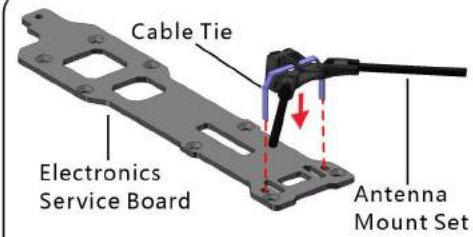

Install the antenna mount set as early as possible

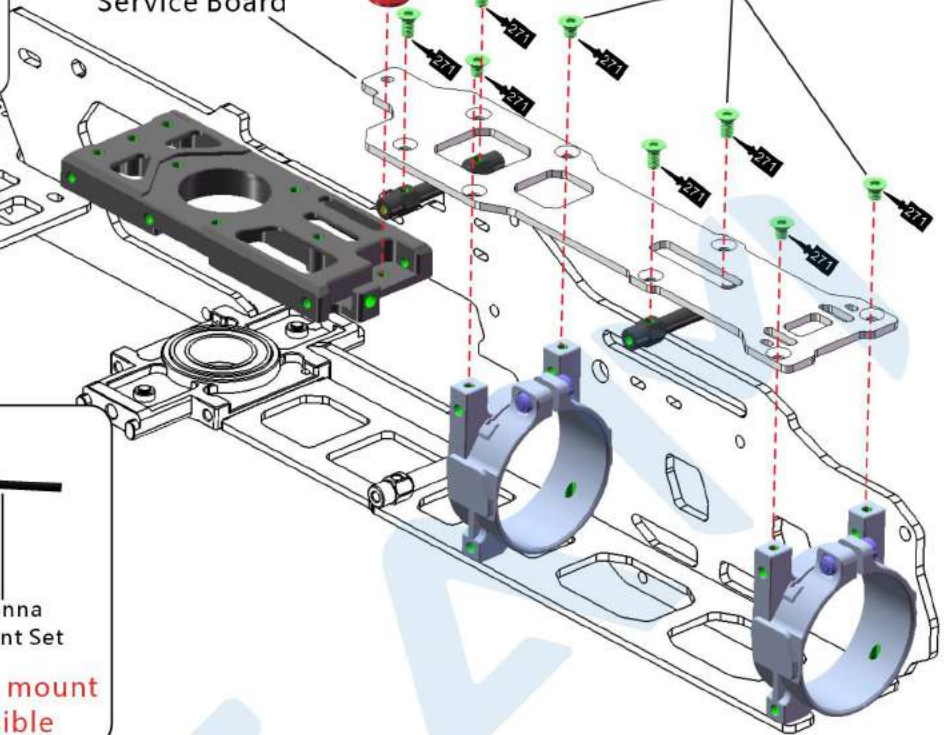

Don't tighten those screws yet.



Button Head Screw M3x6mm

Socket Screw M3x7mm

Socket Screw M3x6mm

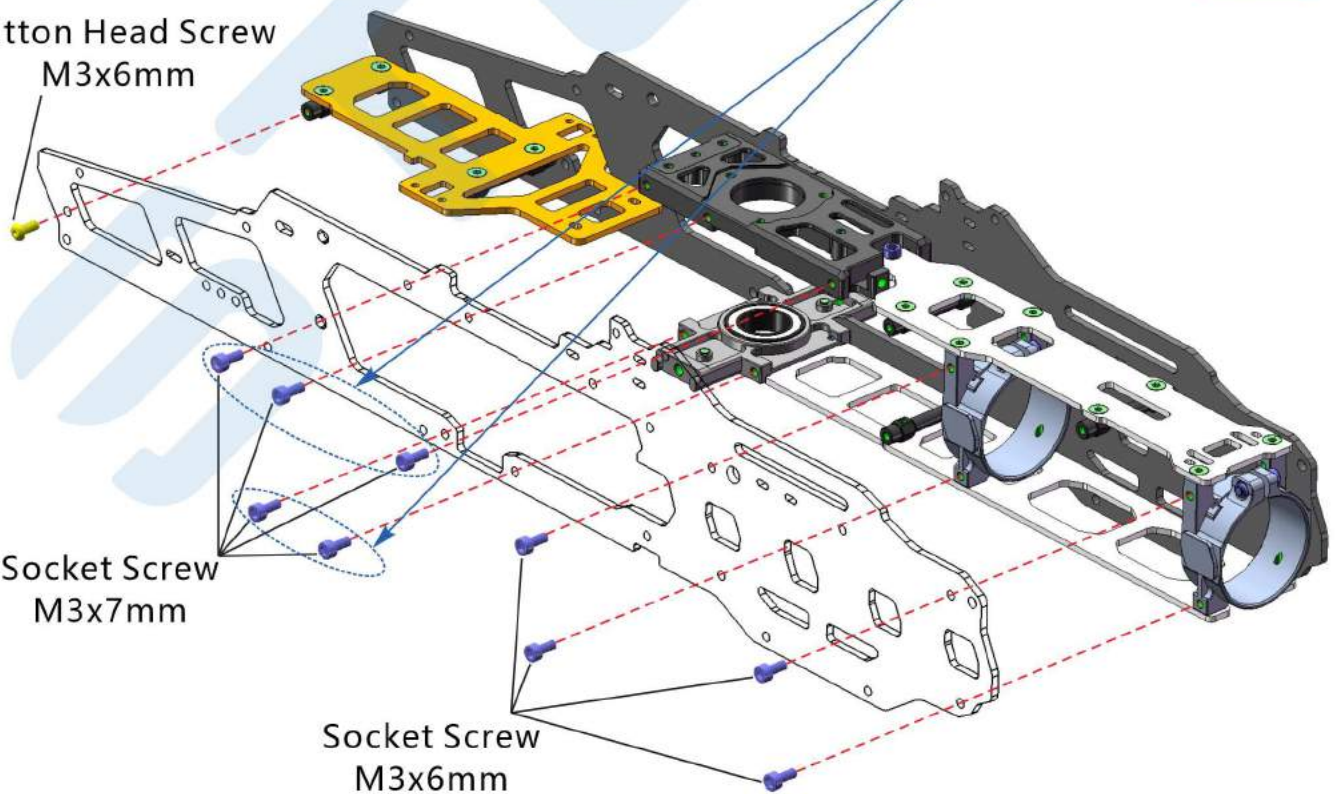

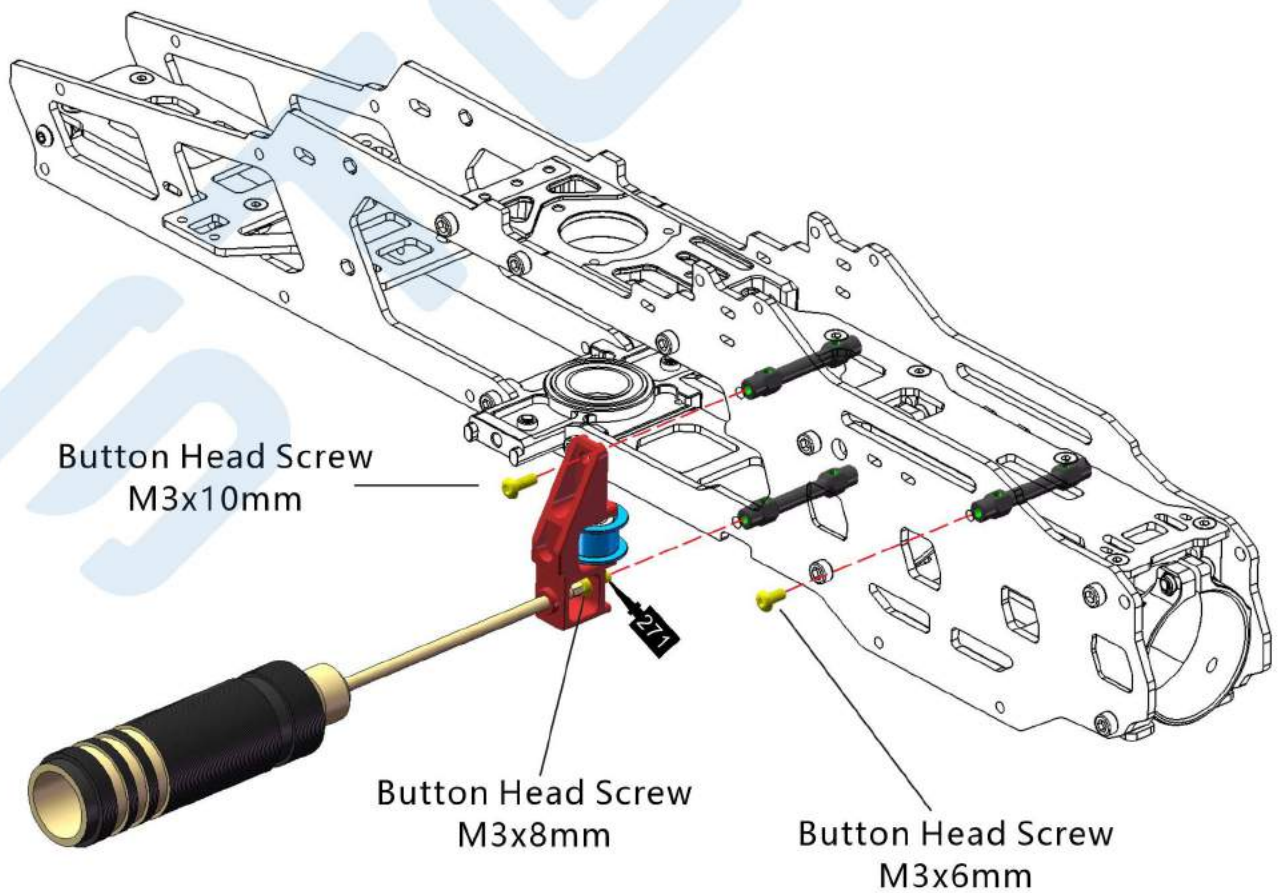
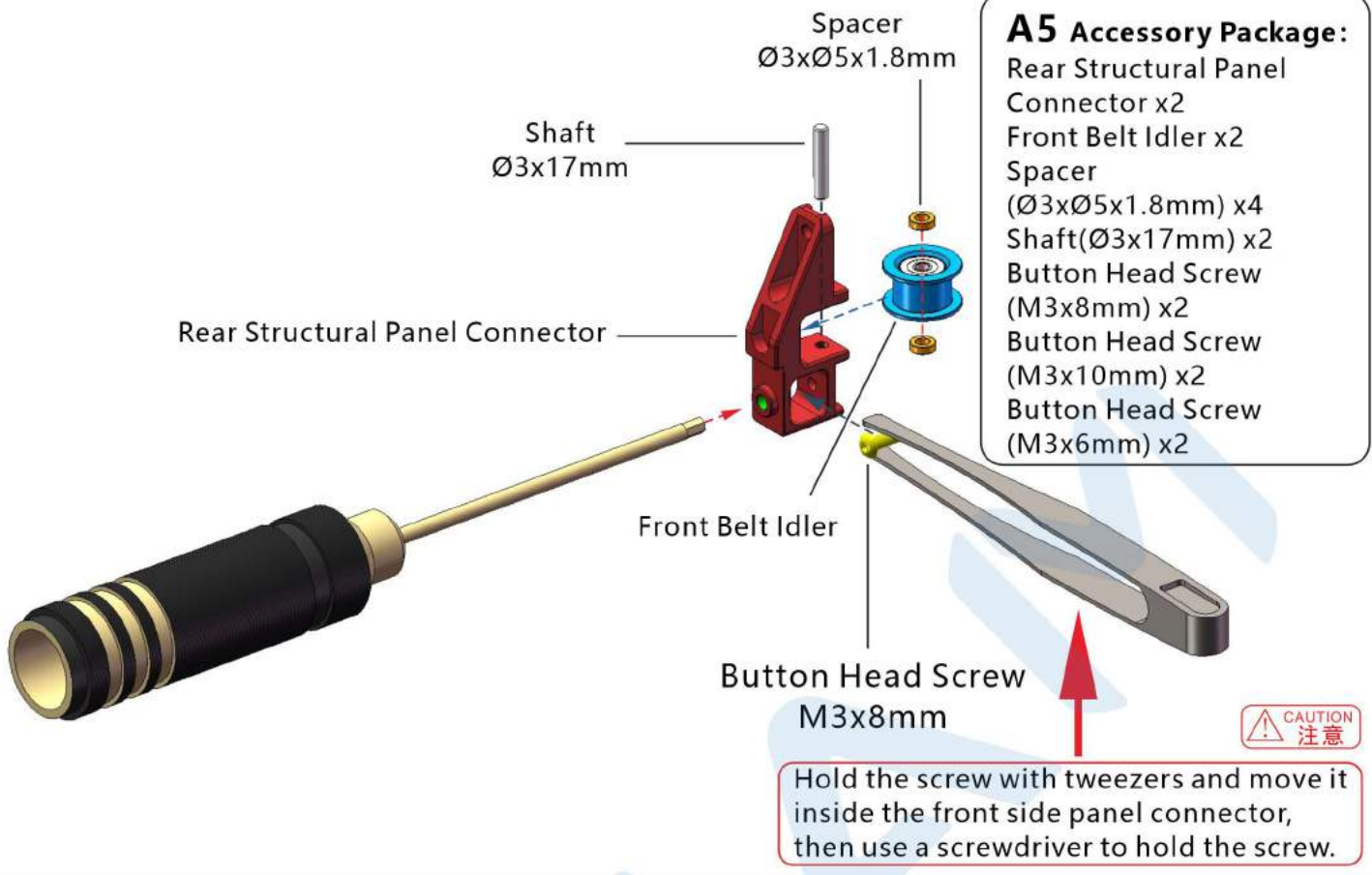



Hold the screw with tweezers and move it inside the front side panel connector, then use a screwdriver to hold the screw.

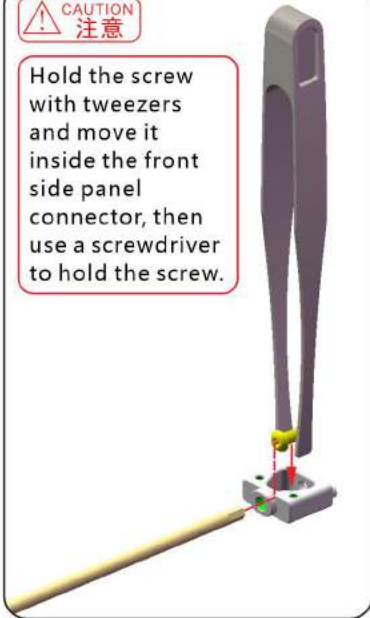

Socket Screw
M2.5x5mm

A6 Accessory Package:

- Front Side Panel Attachment x2
- Socket Screw (M2.5x5mm) x4
- Button Head Screw (M3x8mm) x2

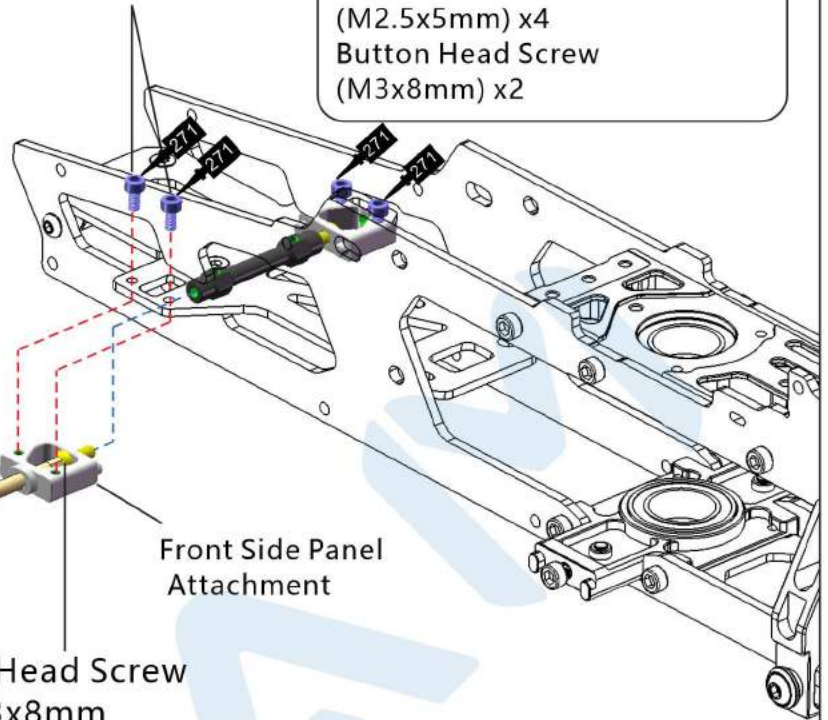

Front Side Panel Attachment

Button Head Screw
M3x8mm



Battery Slot

A7 Accessory Package:

- Battery Slot x2
- Button Head Screw (M3x6mm) x6

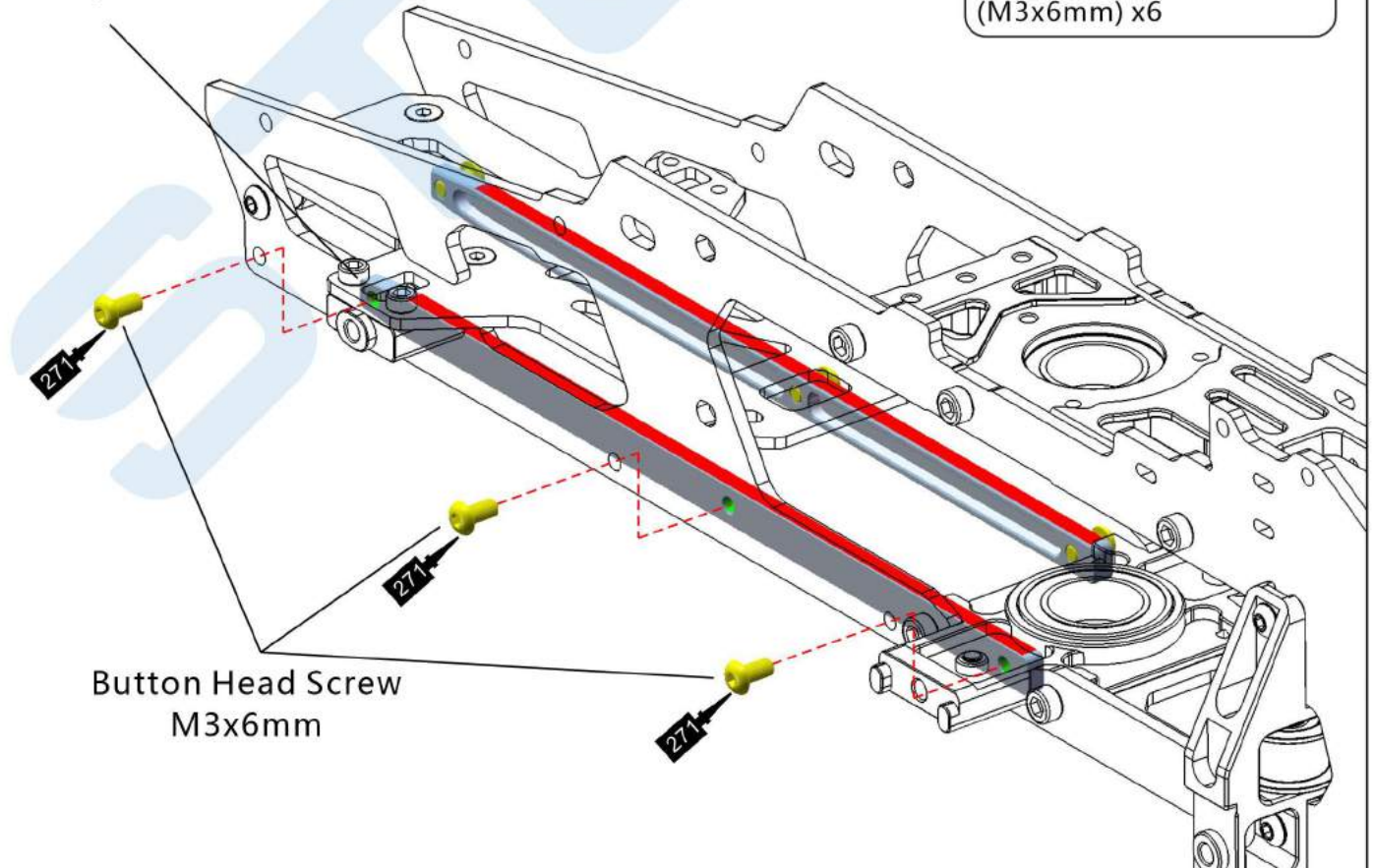

Button Head Screw
M3x6mm

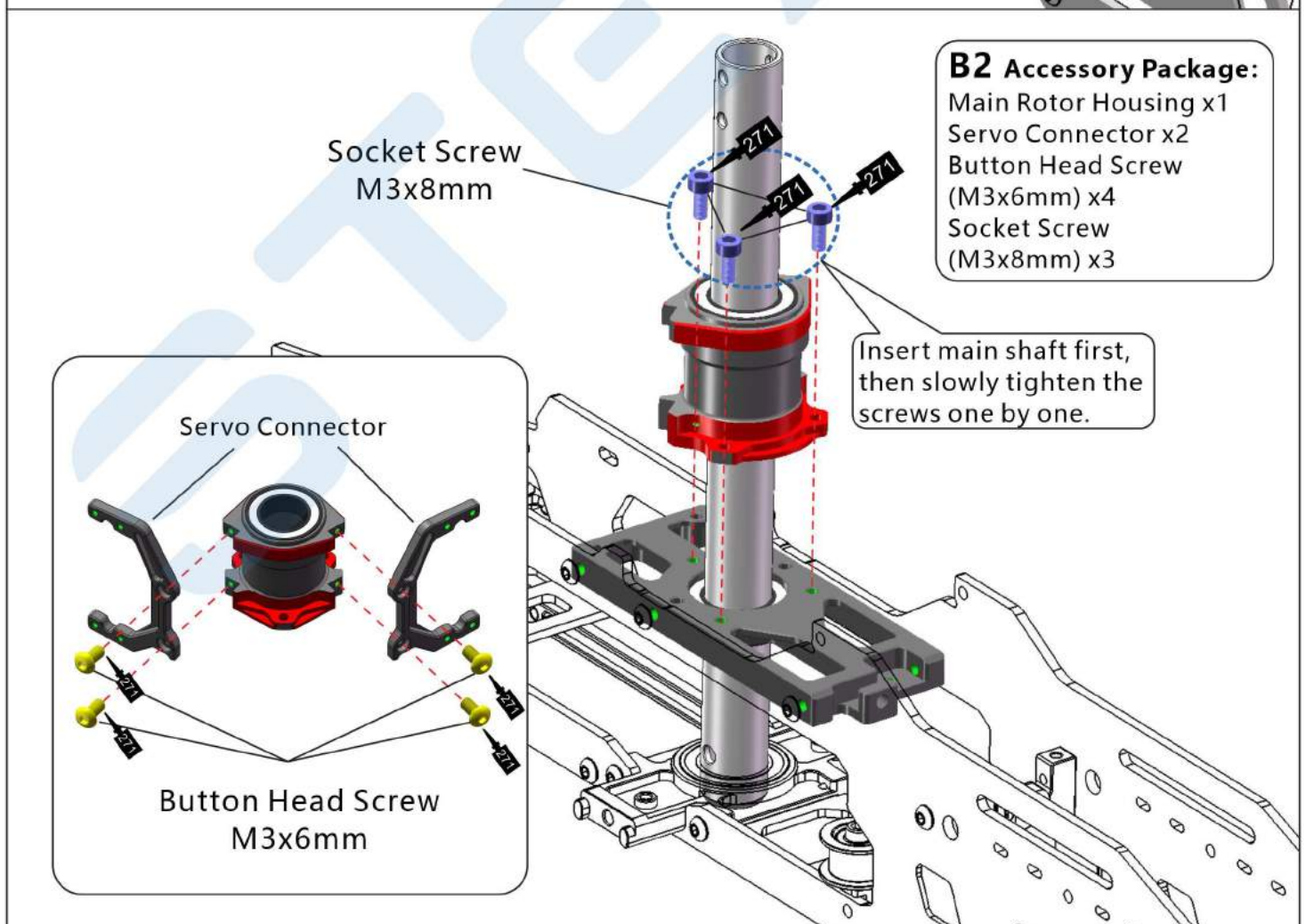
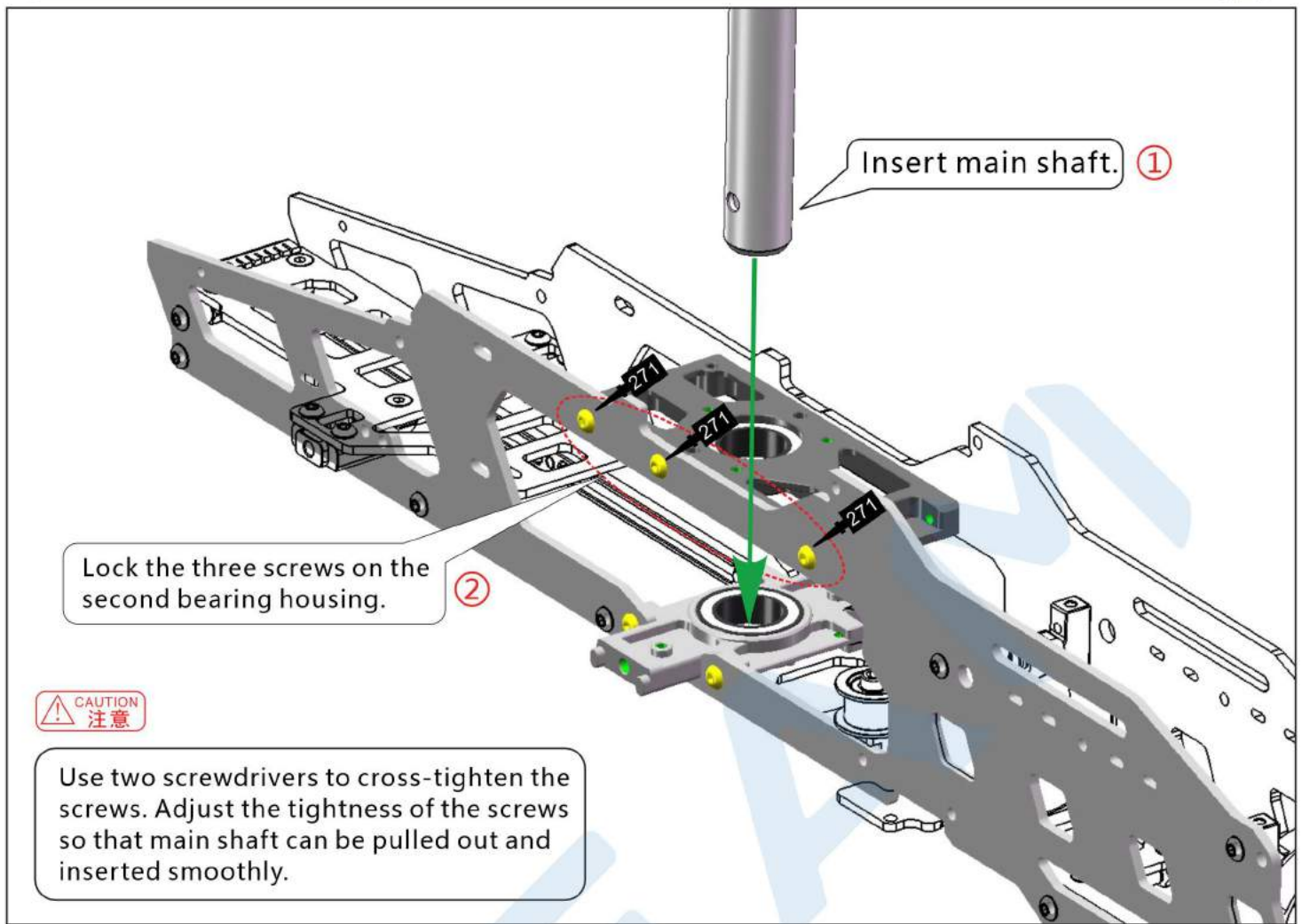

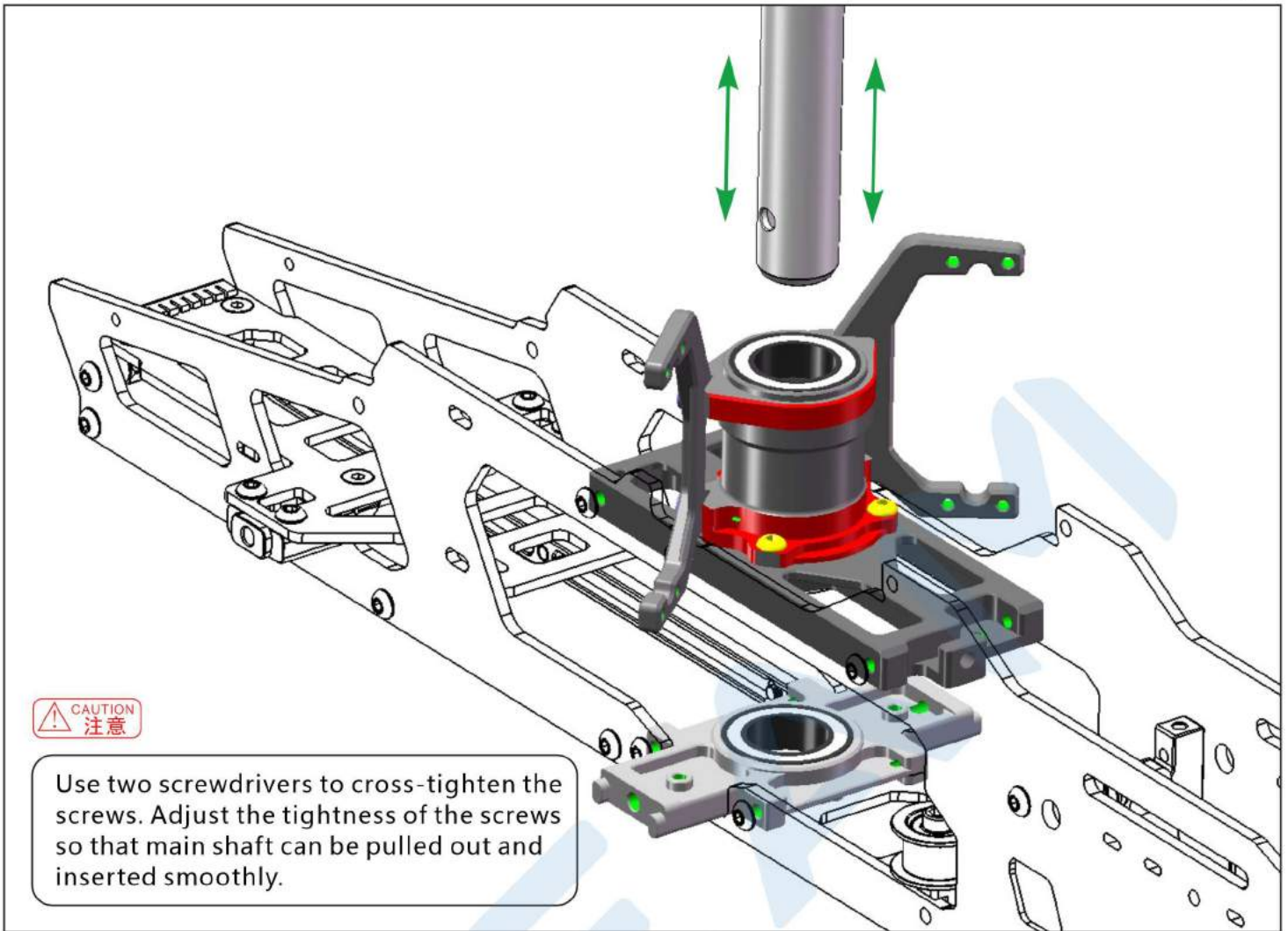

Use two screwdrivers to cross-tighten the screws. Adjust the tightness of the screws so that main shaft can be pulled out and inserted smoothly.

B3 Accessory Package:
 Socket Screw (M2.5x8mm) x8
 Servo Washer x4

Socket Screw
 M2.5x8mm

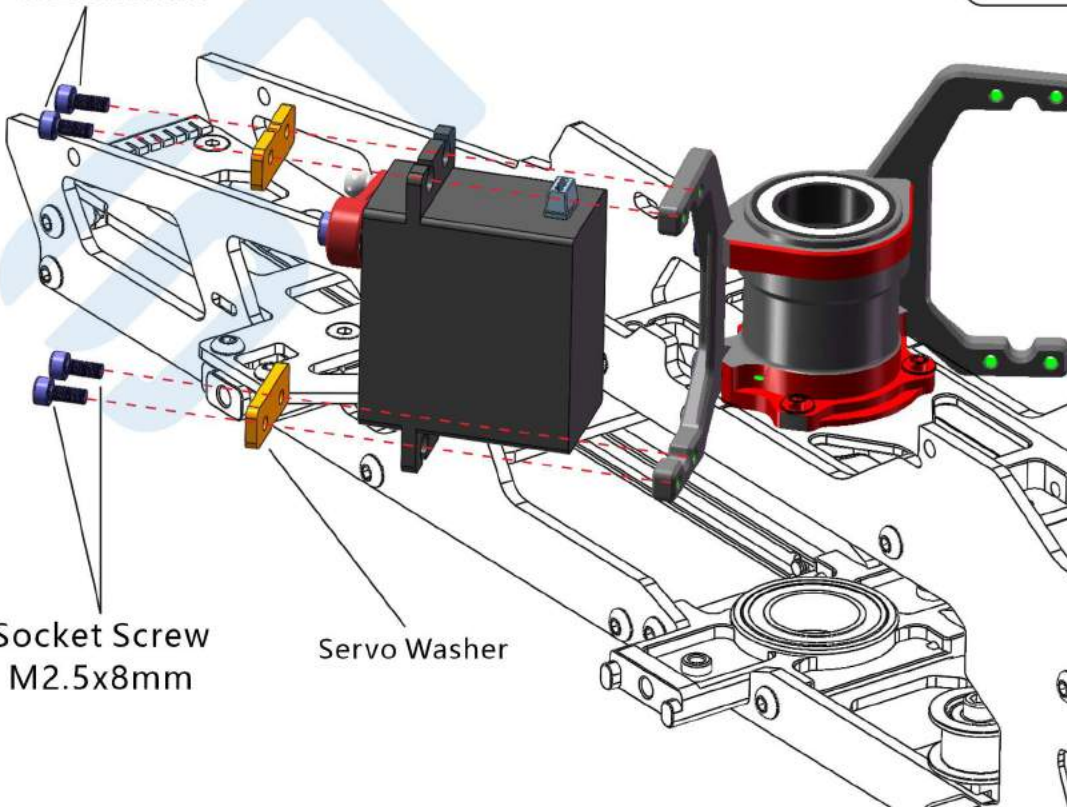

Socket Screw
 M2.5x8mm

Servo Washer



Apply a little amount of 271 thread lock when fixing a metal part.
 所有螺丝锁紧金属件时请使用适量 271 (螺丝胶)

- C2 Accessory Package:**
- Tail Rotor Holder x2
 - Rubber O-Ring (Ø4.5xØ9x2.4mm) x2
 - Washer (Ø5xØ8x0.8mm) x2
 - Bearing (Ø5xØ10x4mm) x2
 - Thrust Bearing (Ø5xØ11x4.5mm) x2
 - Washer (Ø5xØ7x0.3mm) x2
 - Bearing (Ø5xØ11x4mm) x2
 - Washer (Ø4xØ6x0.5mm) x2
 - Socket Screw (M4x6mm) x2

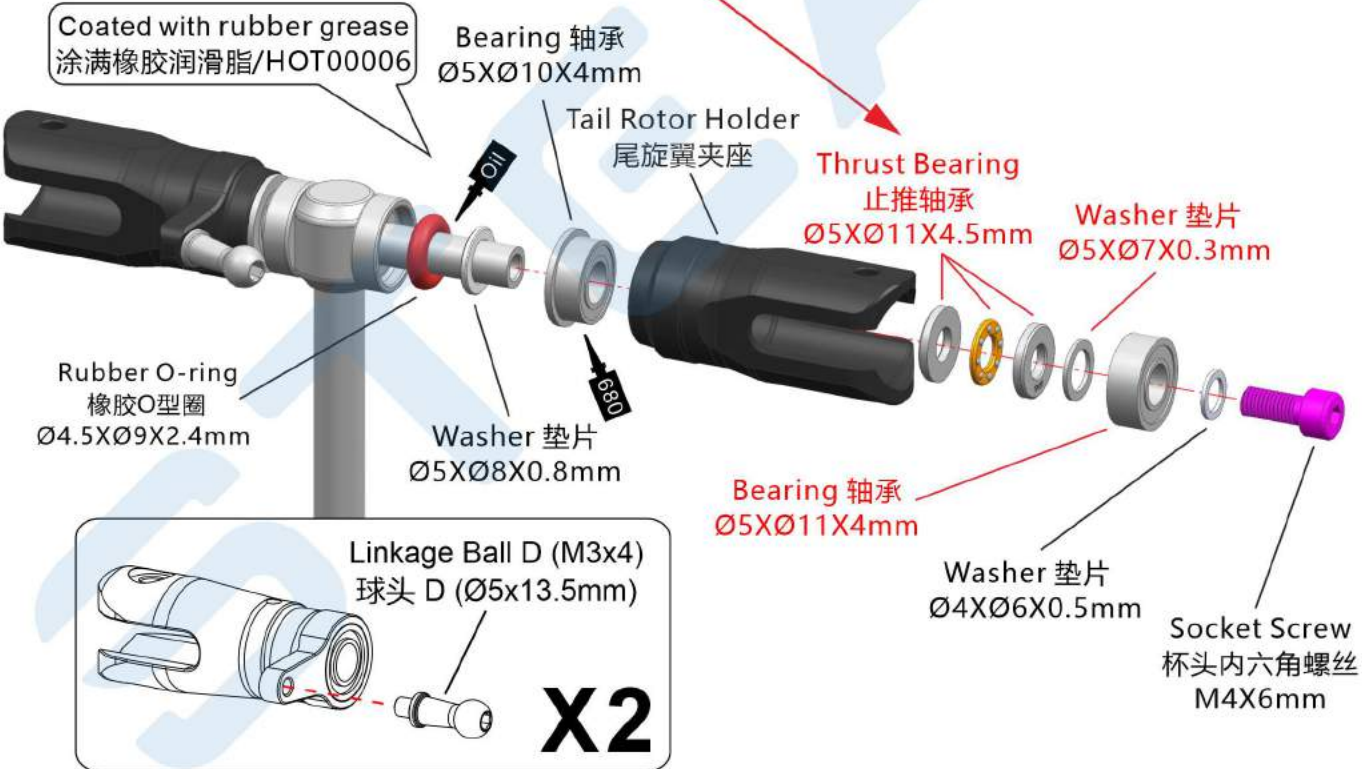
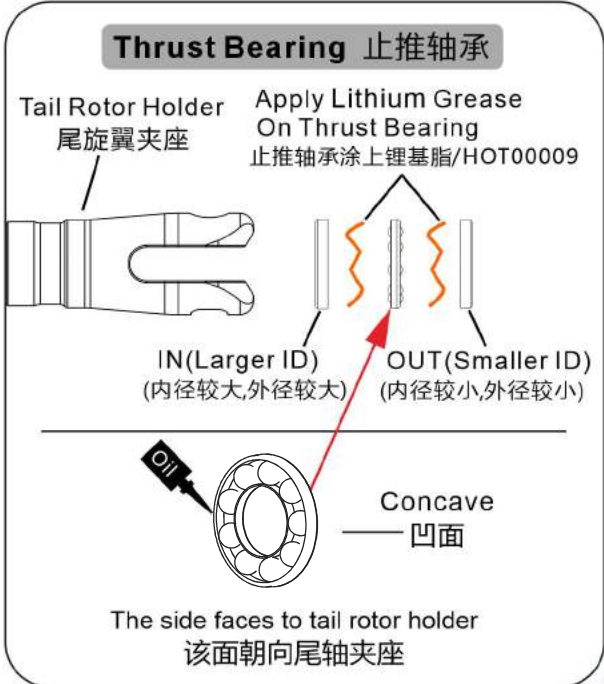

Thrust bearing and washer for radial bearing are wear items ,and thus should be inspected for replacement after every 15~20 flights. For flights with high headspeed , the inspection interval should be reduced to ensure flight safety.
 止推轴承及横轴垫圈属于飞行消耗品,建议15~20趟定期检查及更换。主旋翼高转速飞行时,请缩短定期检查的趟数,以确保飞行安全。



Tail Rotor Hub Assembly
尾主轴



A outside
A字朝外

C3 Accessory Package:
Tail Control Linkage Head x2
T Type Control Arm x1
Socket Screw (M2x8mm) x2
Bearing (Ø8xØ12x3.5mm) x2
Tail Control Bearing Bush x1
Tail Shaft Slide Bush x1

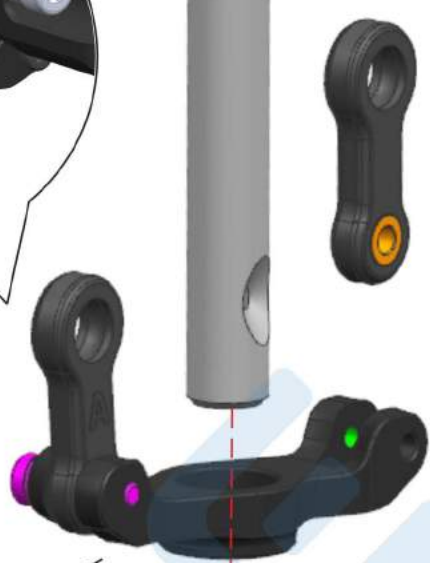

T Type Arm
T型控制臂

Bearing
轴承

Ø8XØ12X3.5mm

Bearing Holder
尾控制轴承套

Bearing
轴承

Ø8XØ12X3.5mm

Socket Screw
杯头内六角螺丝
M2X8mm

Slide Shaft
尾轴滑套

Already apply the glue
已打胶



It's forbidden to use high-gloss bearing rubber to prevent over-tightening and lead to future maintenance.
严禁使用高胶合性轴承胶,防止胶合过紧导致日后维修不便.



For original manufactory package , if the product is already assembled by factory , please check again if screws are firmly secured and applied with some glue.
原装零件出厂包装如果组装完毕,请需再确认各螺丝是否锁紧上胶.

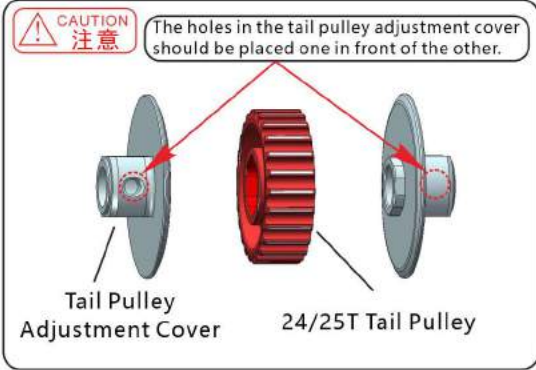

C4 Accessory Package:

- Tail Pulley Adjustment Cover x2
- 24/25T Tail Pulley x1
- Belt x1
- Metal Tail Gear Box x1
- Set Screw (M4x4mm) x2

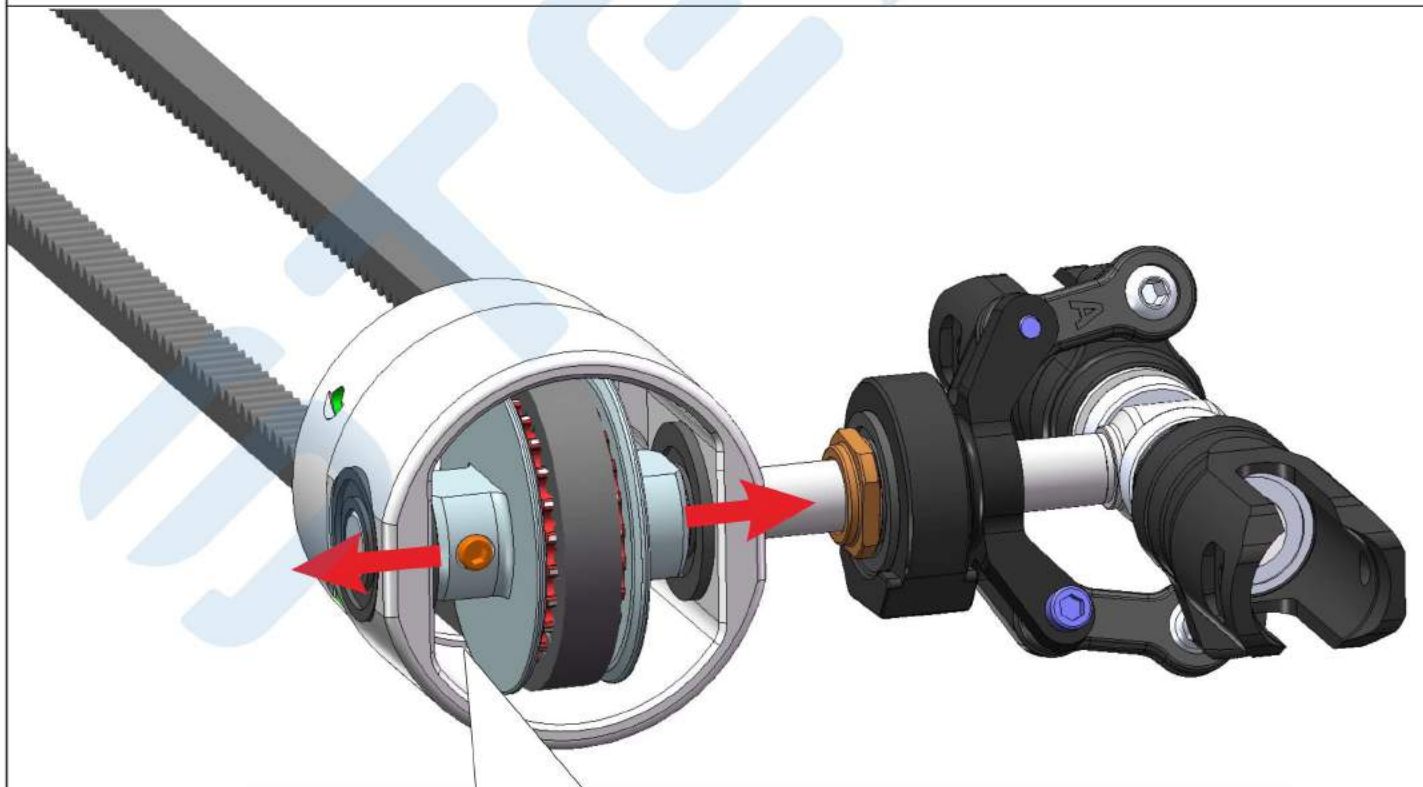
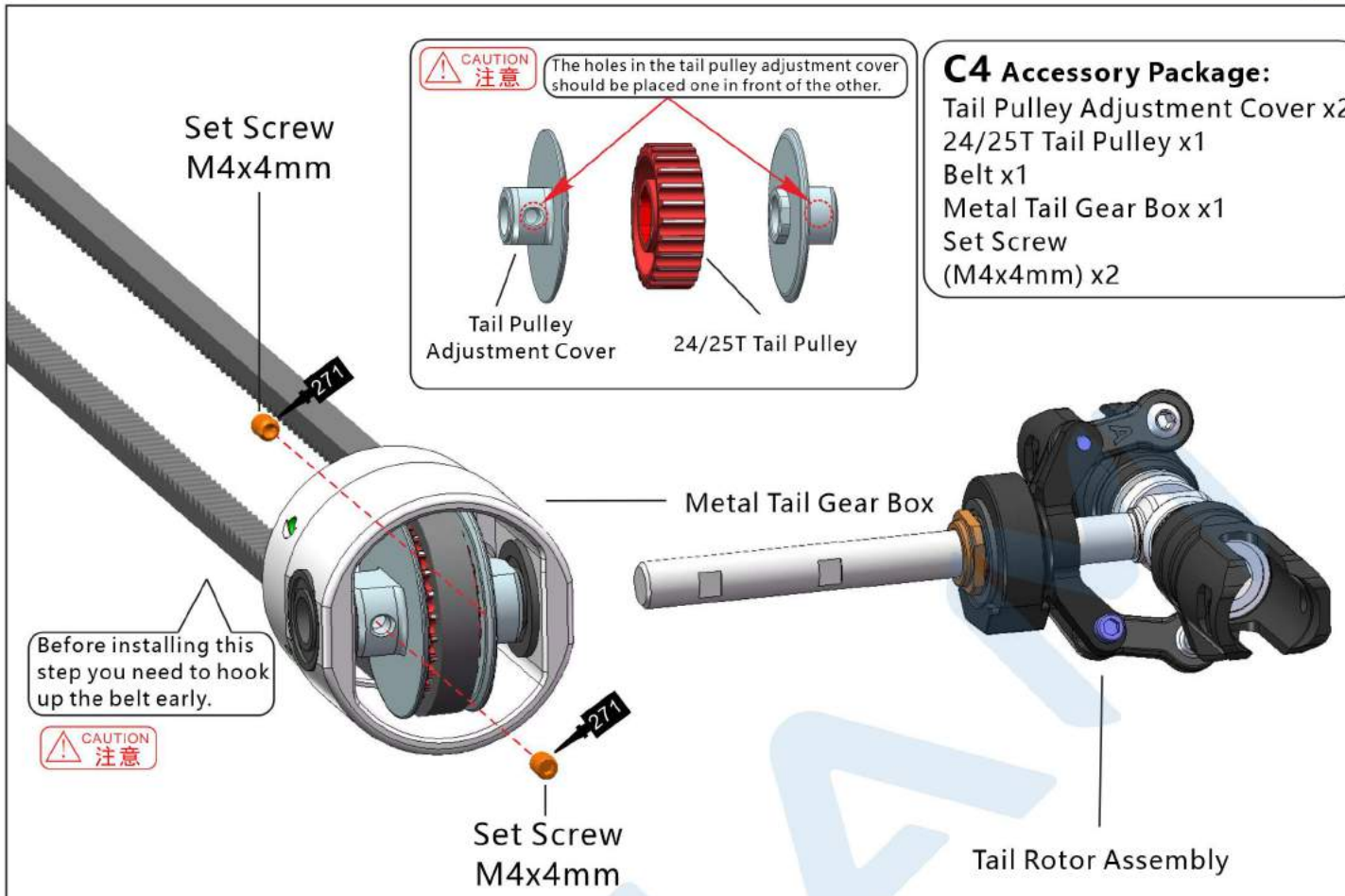

Please adjust the tail gear stopper outward until there is no space, and then lock set screw. (There is also a set screw on the back)

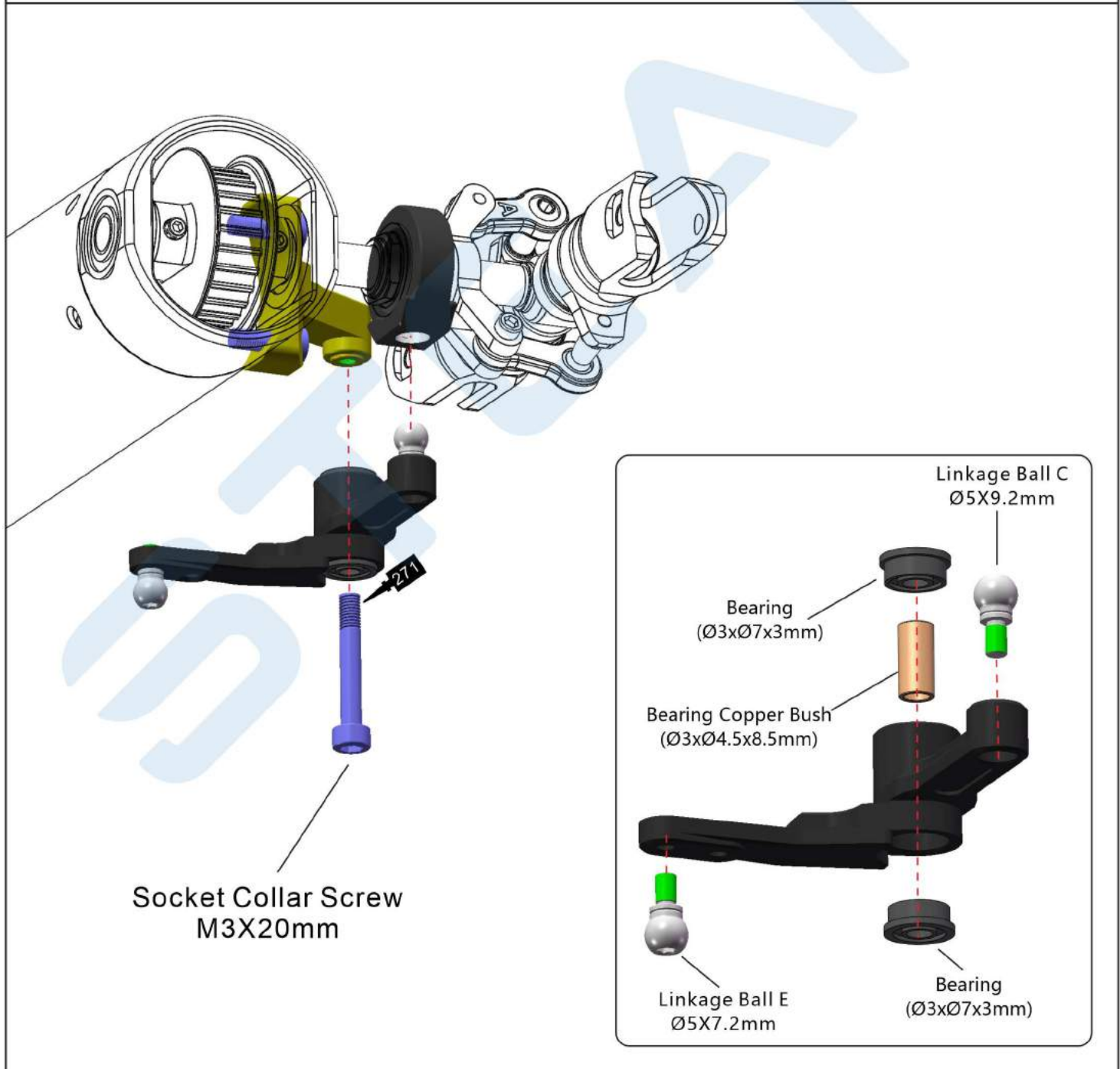
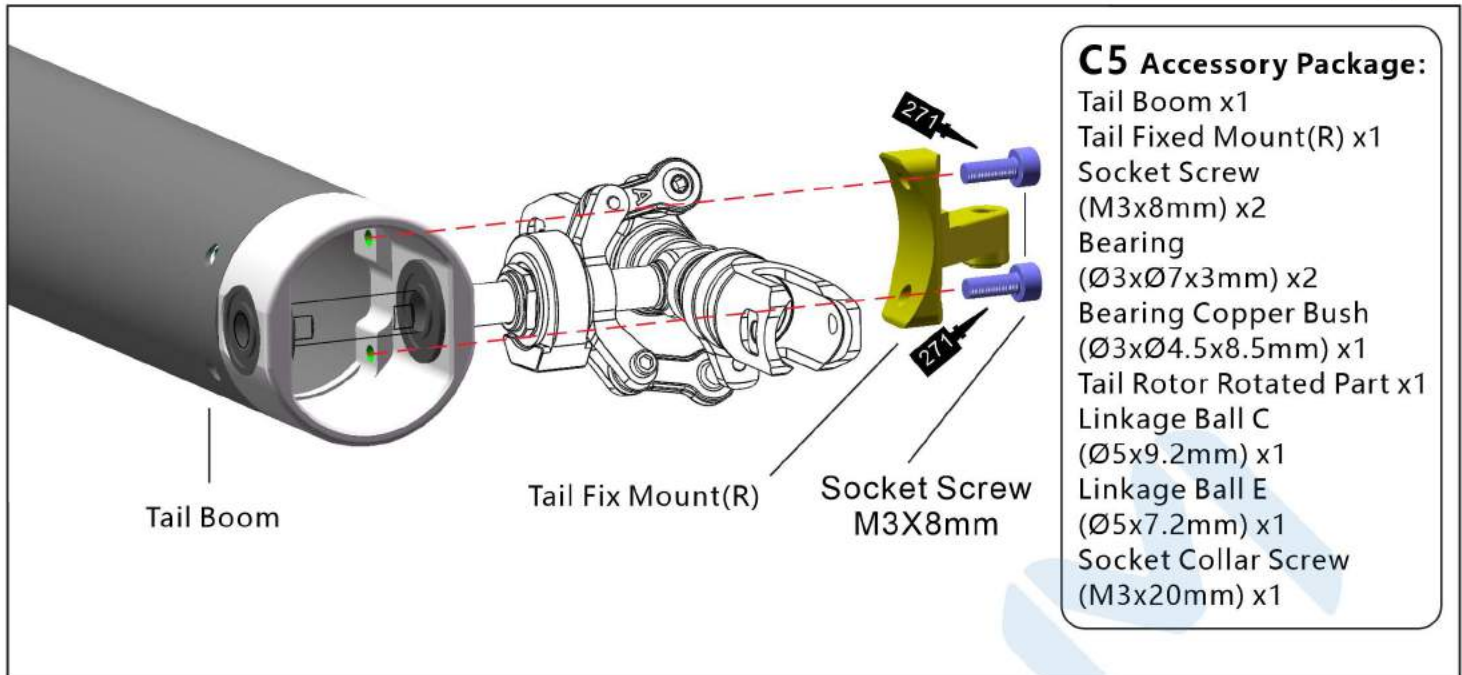

C6 Accessory Package:

- Socket Screw (M3x10mm) x2
- Vertical Fin x1
- Tail Fixed Mount(L) x1

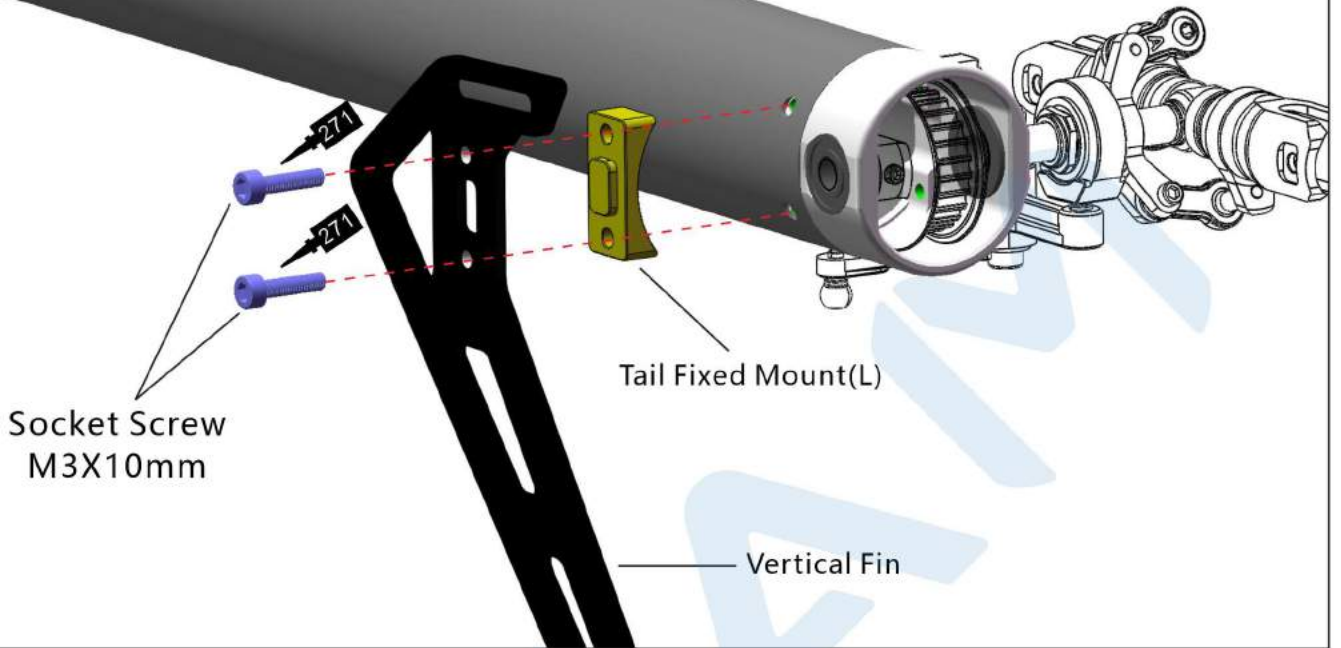

C7 Accessory Package:

- Tail Linkage Rod Clamp Mount x2
- Socket Screw (M2x8mm) x2
- Nut(M2) x2

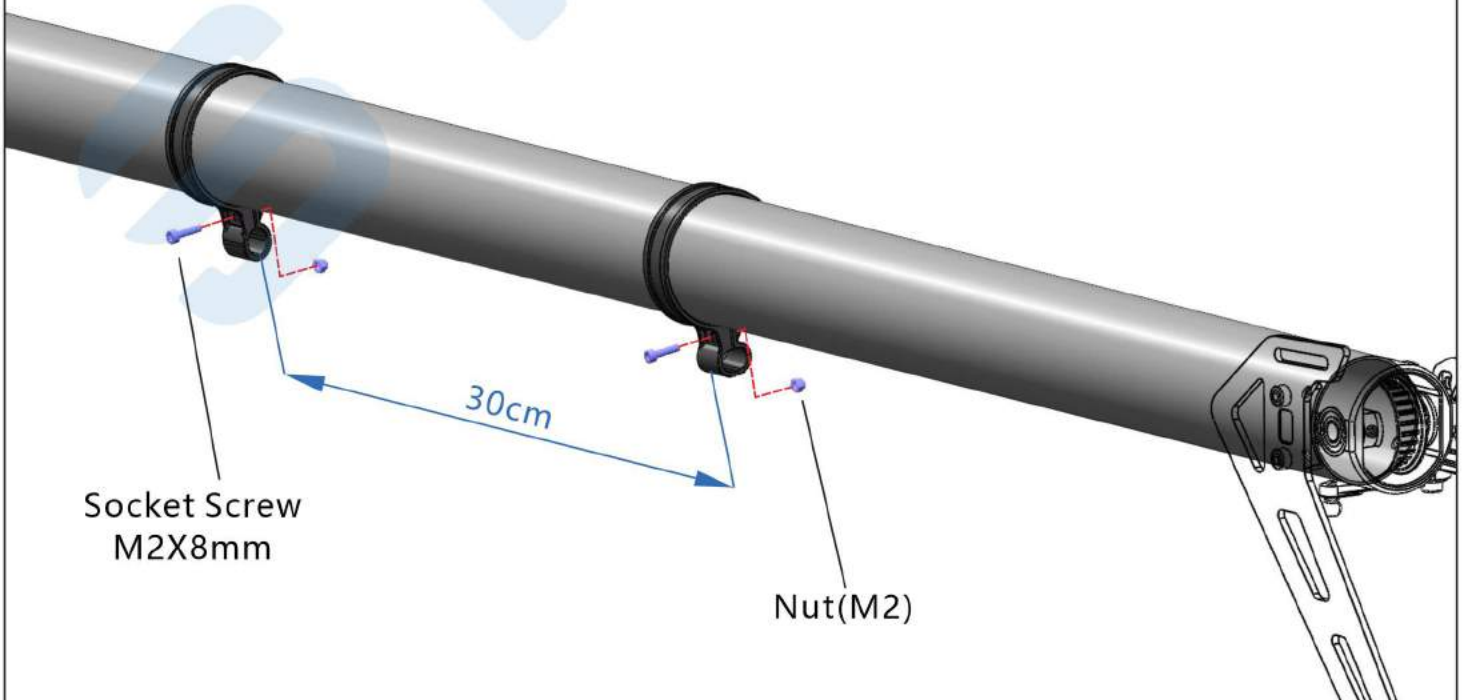

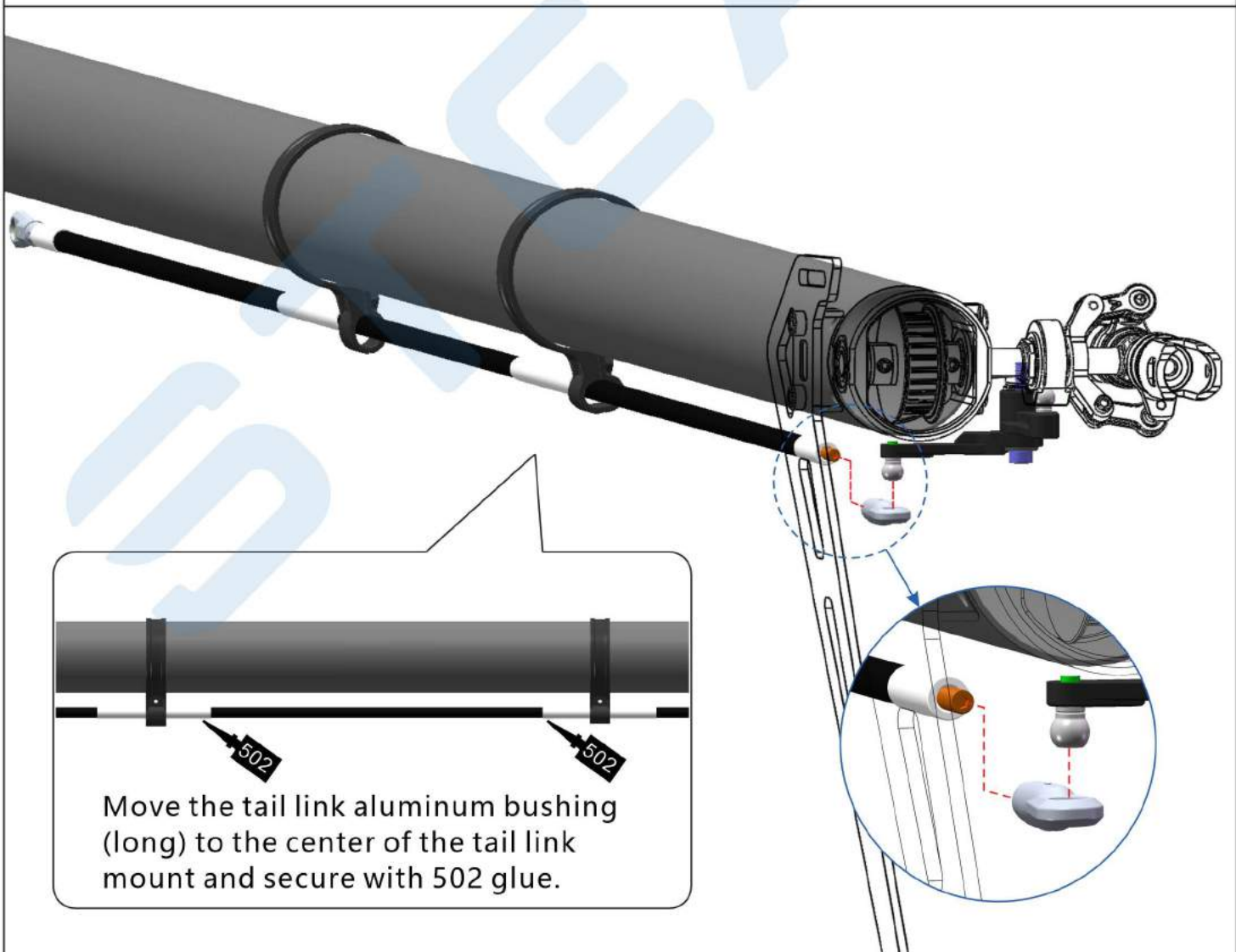
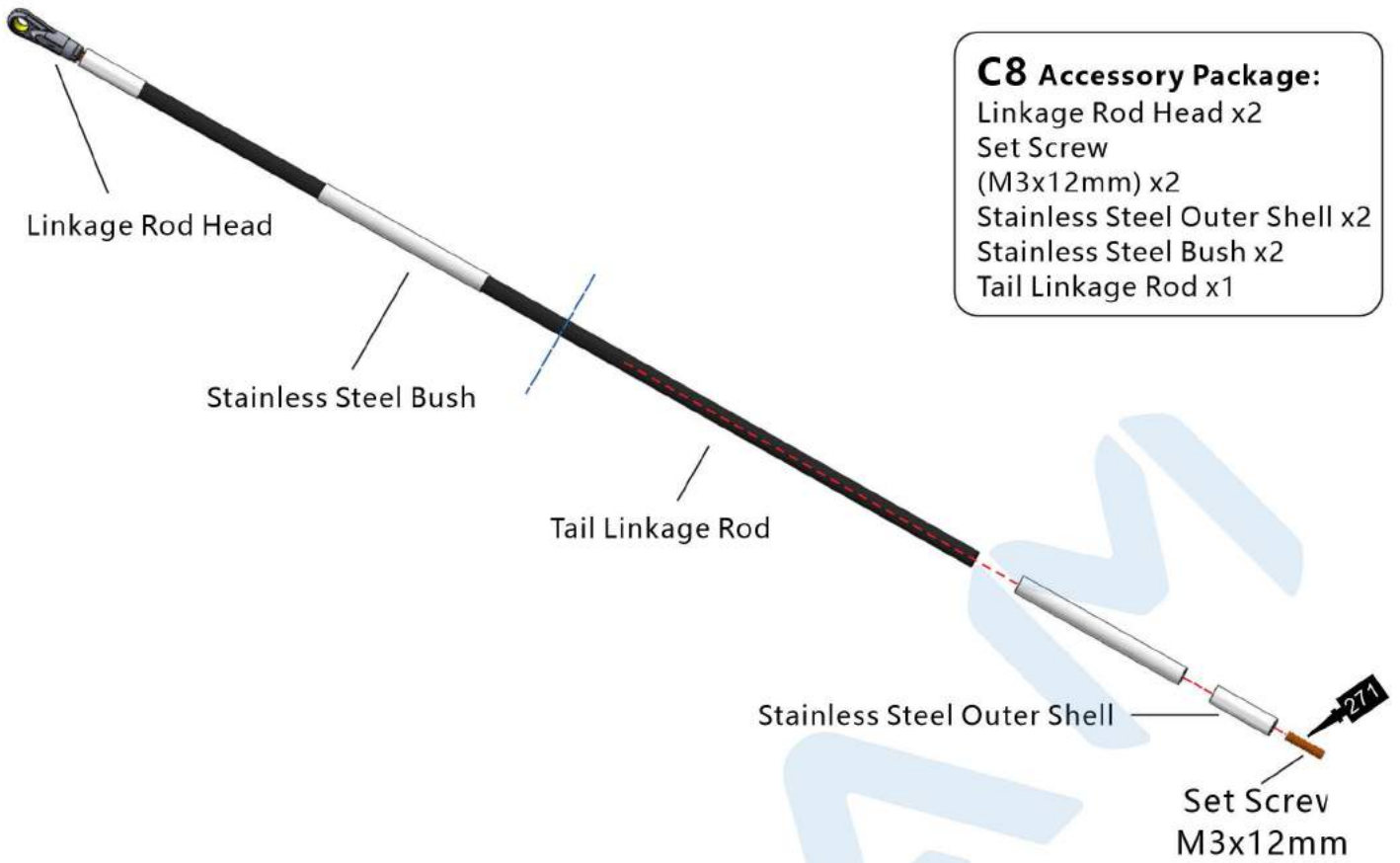

The bearing gap needs to be coated with lithium grease.
(About 1 gram)
轴承缝隙需要涂满锂基脂
(大约1g) /HOT00009



Wedge Bearings

Graphite Bearing

A8 Accessory Package:
Graphite Bearing x2
Center Seat Aluminum Ring x1
Wedge Bearings x1
127T Main Gear x1
Socket Screw
(M2.5x6mm) x6

127T Main Gear

Center Seat Aluminum Ring

Socket Screw
M2.5X6mm

Installation of Bushing Retaining Ring and Bearing

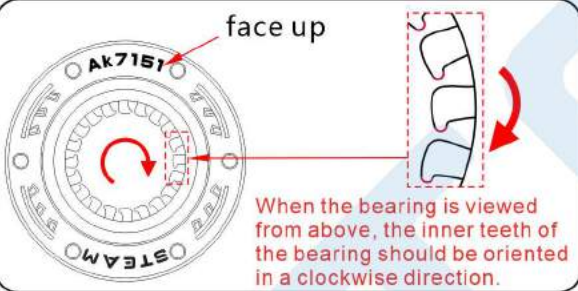

Coated with lithium grease
涂满锂基脂/HOT00009

Graphite Bearing



Crossing the locking screws several times.

Spacer
($\text{Ø}15 \times \text{Ø}21 \times 0.5 \text{mm}$)

Insert main shaft first,
then tighten the screws

Socket Screw
M2.5X5mm



Front Pulley

A9 Accessory Package:
Spacer($\text{Ø}15 \times \text{Ø}21 \times 0.5 \text{mm}$) x1
Socket Screw
(M2.5x5mm) x3
Front Pulley x1
Front Pulley Housing x1

Front Pulley Housing

Tail Dive Belt Installation Diagram

尾传动皮带安装示意图

Turn the main rotor clockwise by hand, the tail rotor will turn back clockwise, if different, it means the belt is twisted in the wrong direction.

Tail Rotor(Clockwise)

Main Rotor(Clockwise)

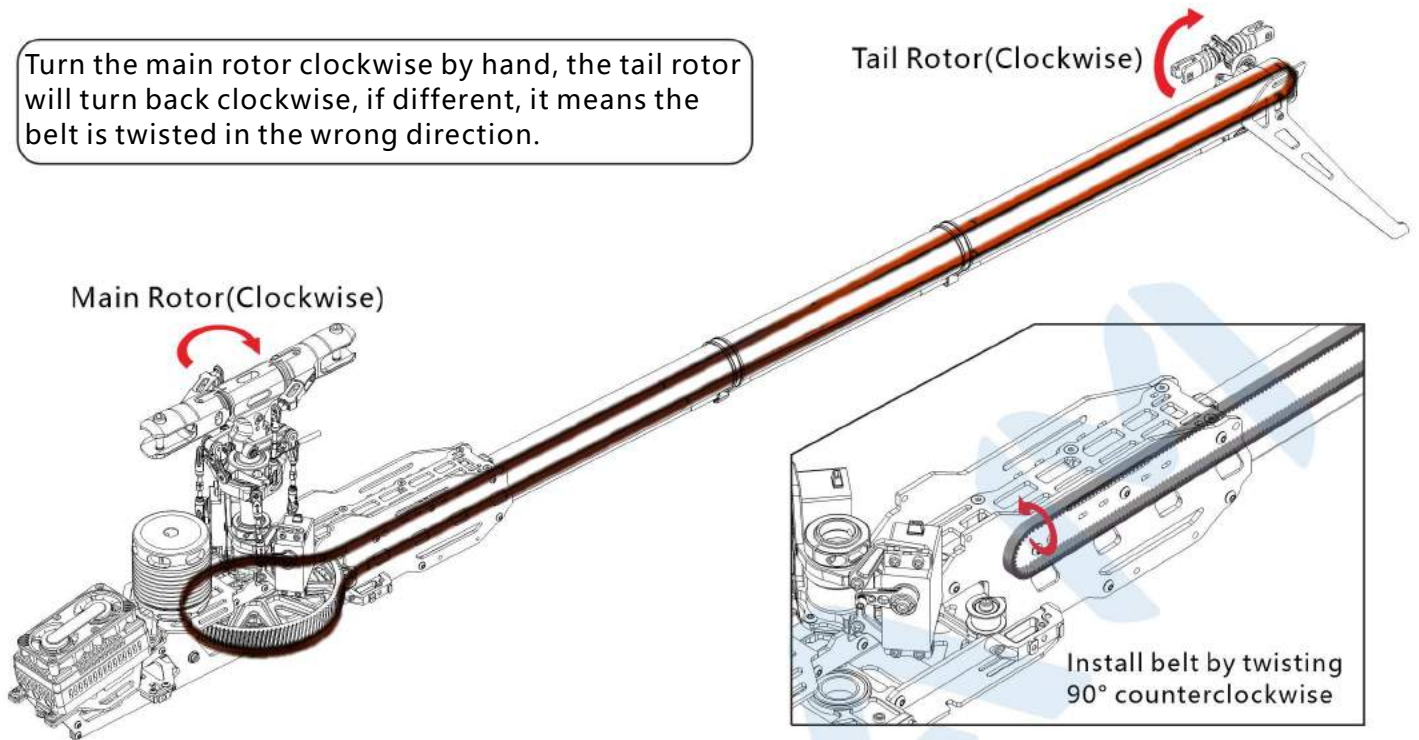

Main Shaft

Main Shaft Locating Ring

A10 Accessory Package:

Main Shaft Locating Ring x1
 Socket Collar Screw
 (M4x25mm) x1
 Socket Screw
 (M3x12mm) x1
 Set Screw
 (M4x7mm) x1

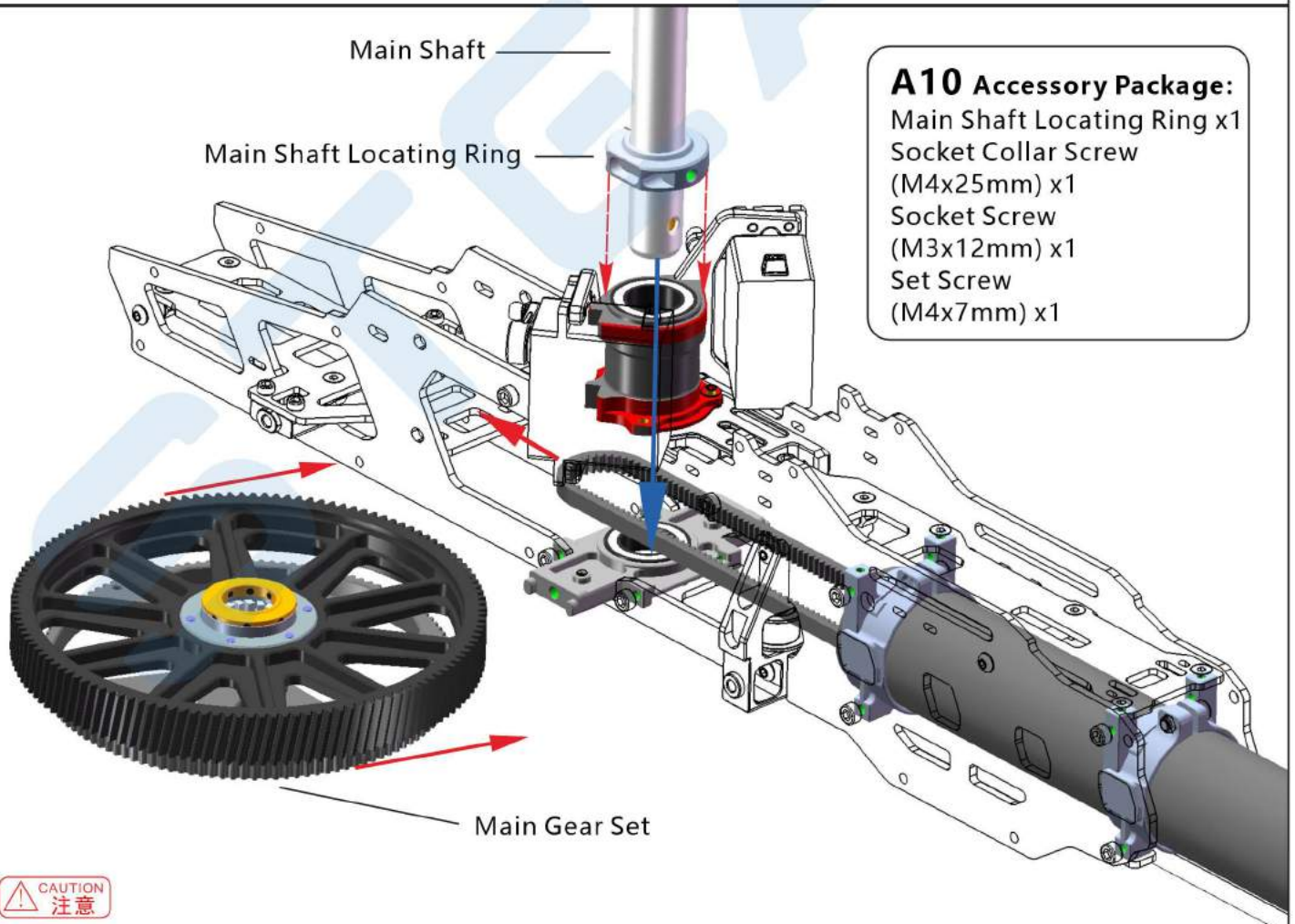

Pull out the belt first, then install the main gear set.

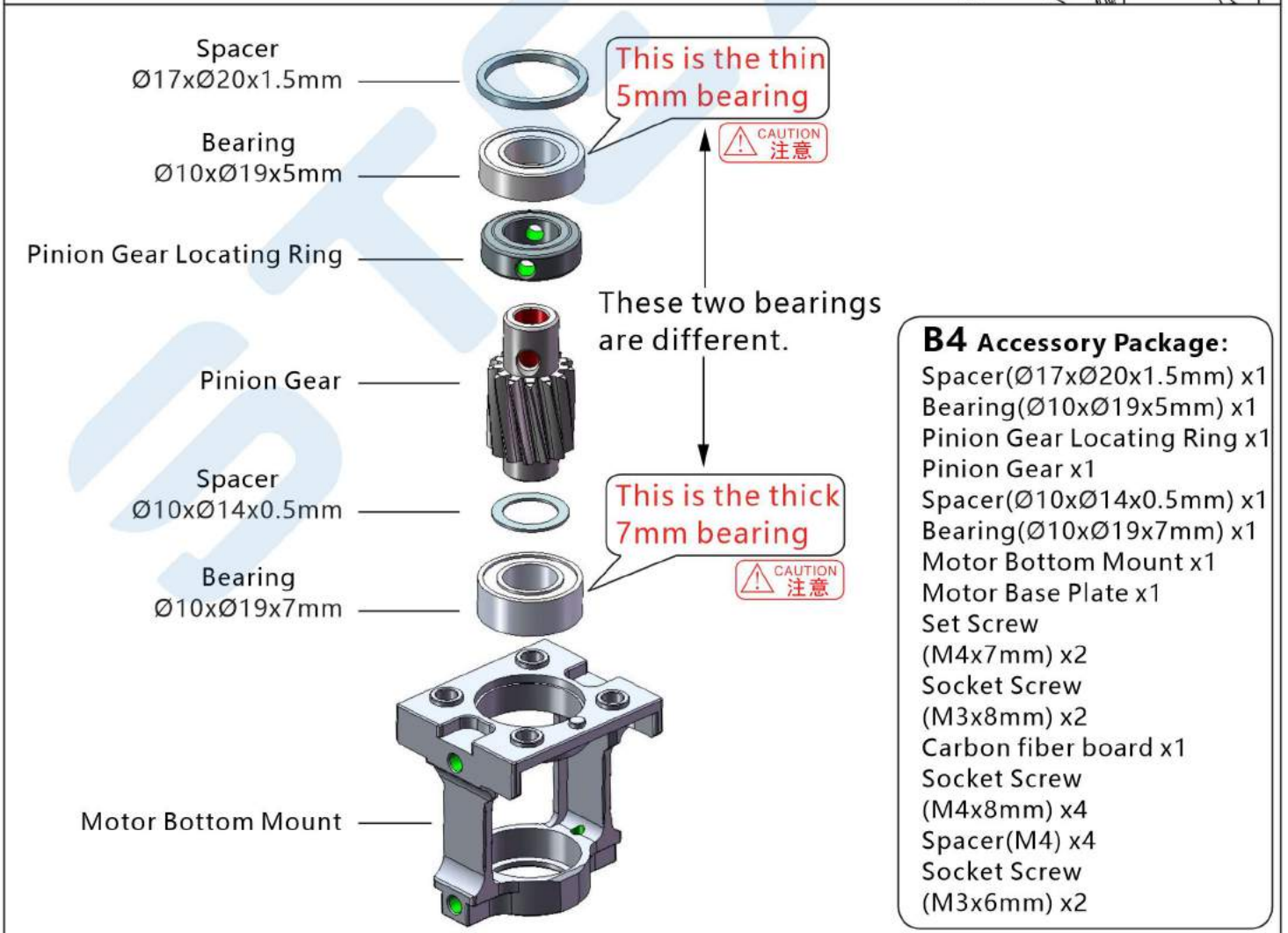
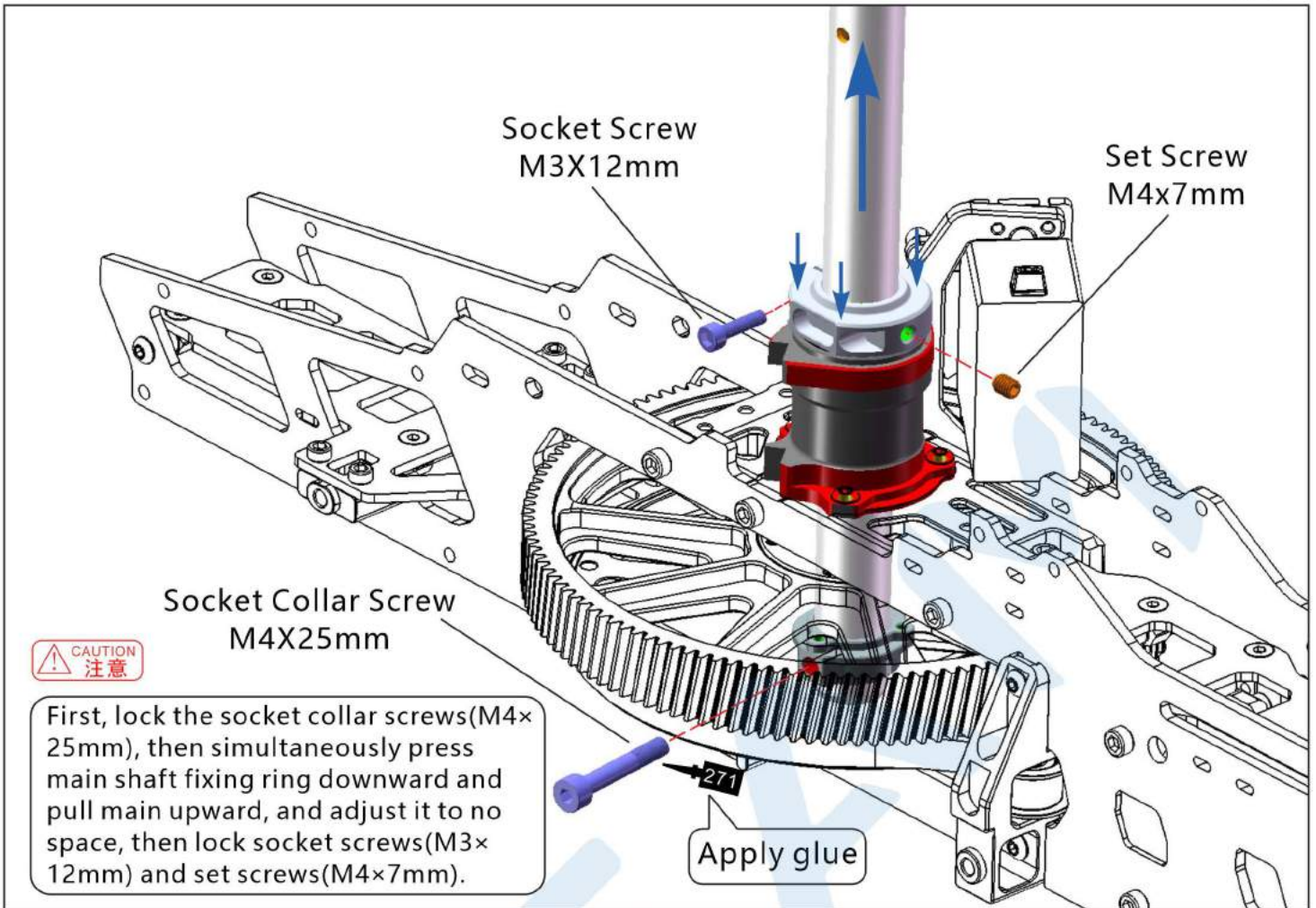

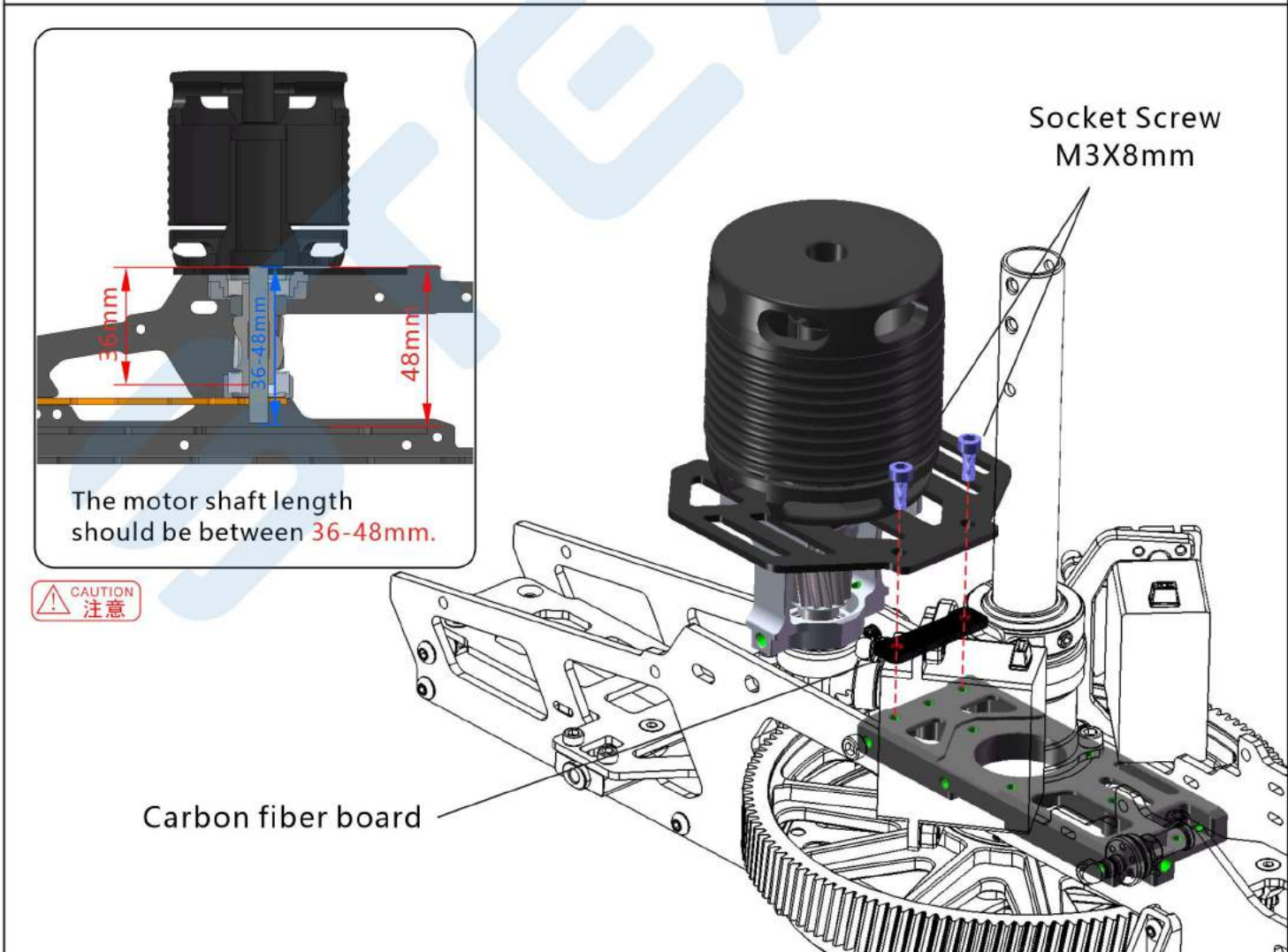
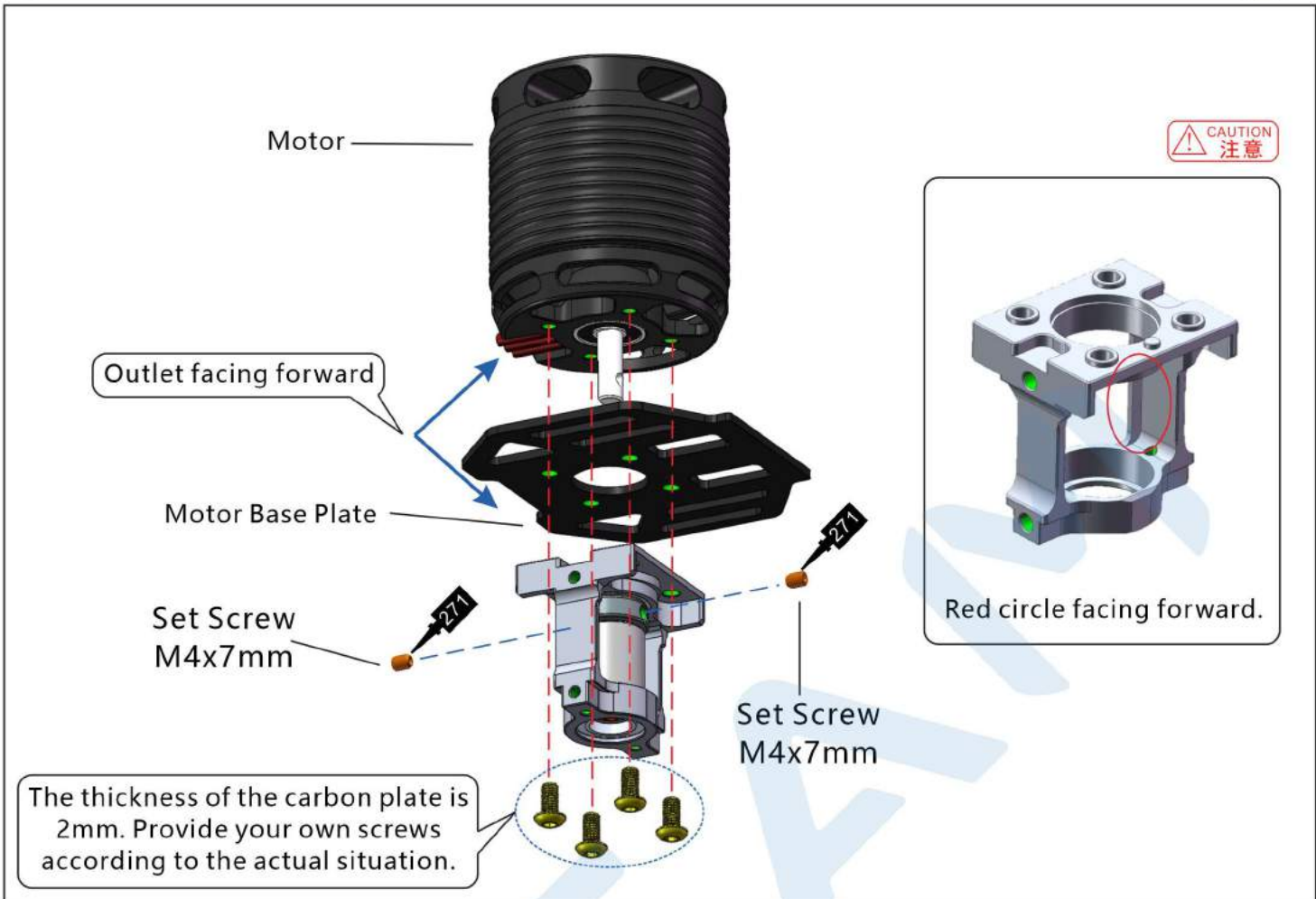

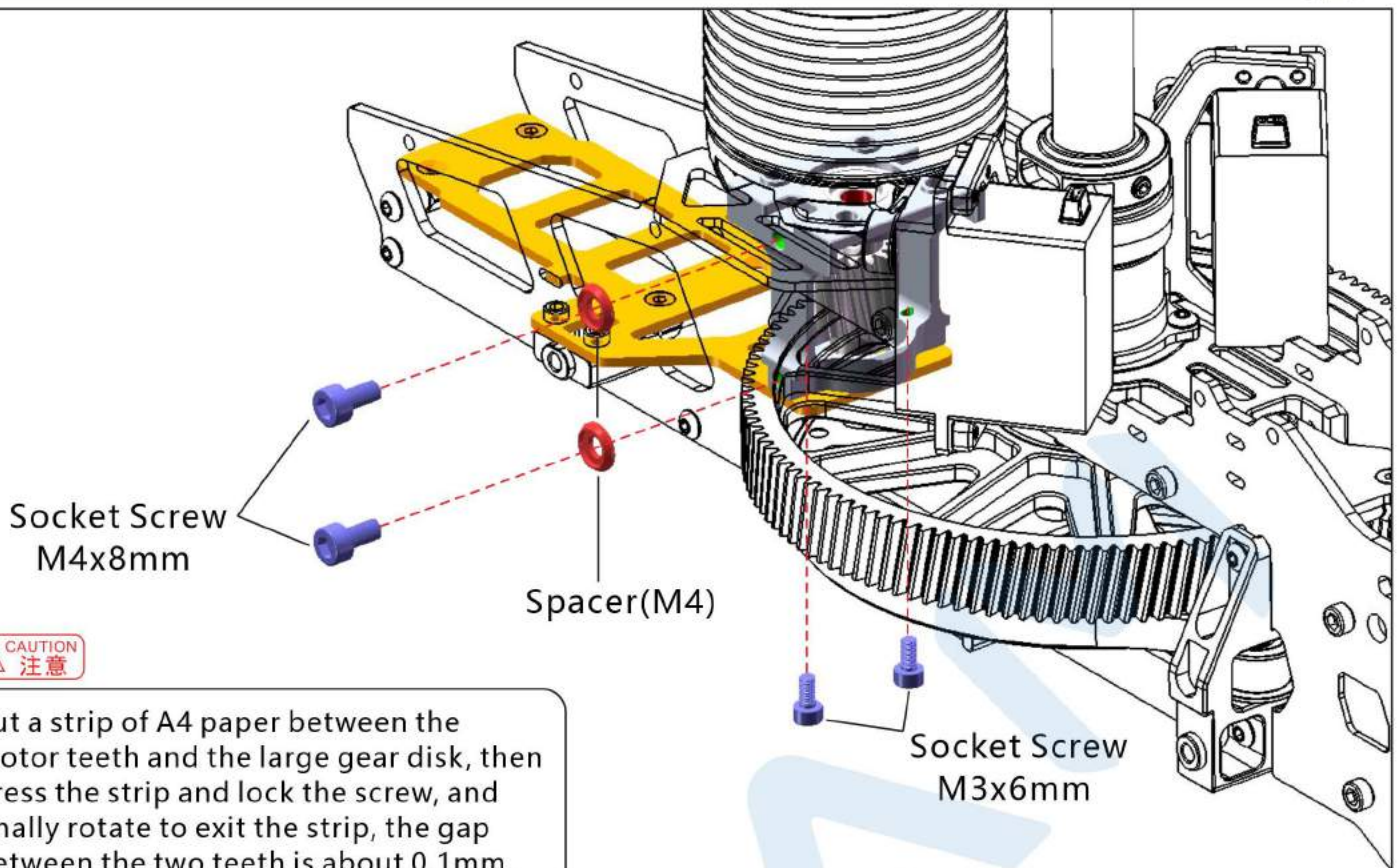

Put a strip of A4 paper between the motor teeth and the large gear disk, then press the strip and lock the screw, and finally rotate to exit the strip, the gap between the two teeth is about 0.1mm.

The thickness of the carbon plate is 2mm. Provide your own screws according to the actual situation.

A11 Accessory Package:

Flat Head Socket Screw (M3x6mm) x4
 ESC Base Plate x1
 Aluminum Column x2
 Button Head Socket Screw (M3x6mm) x4

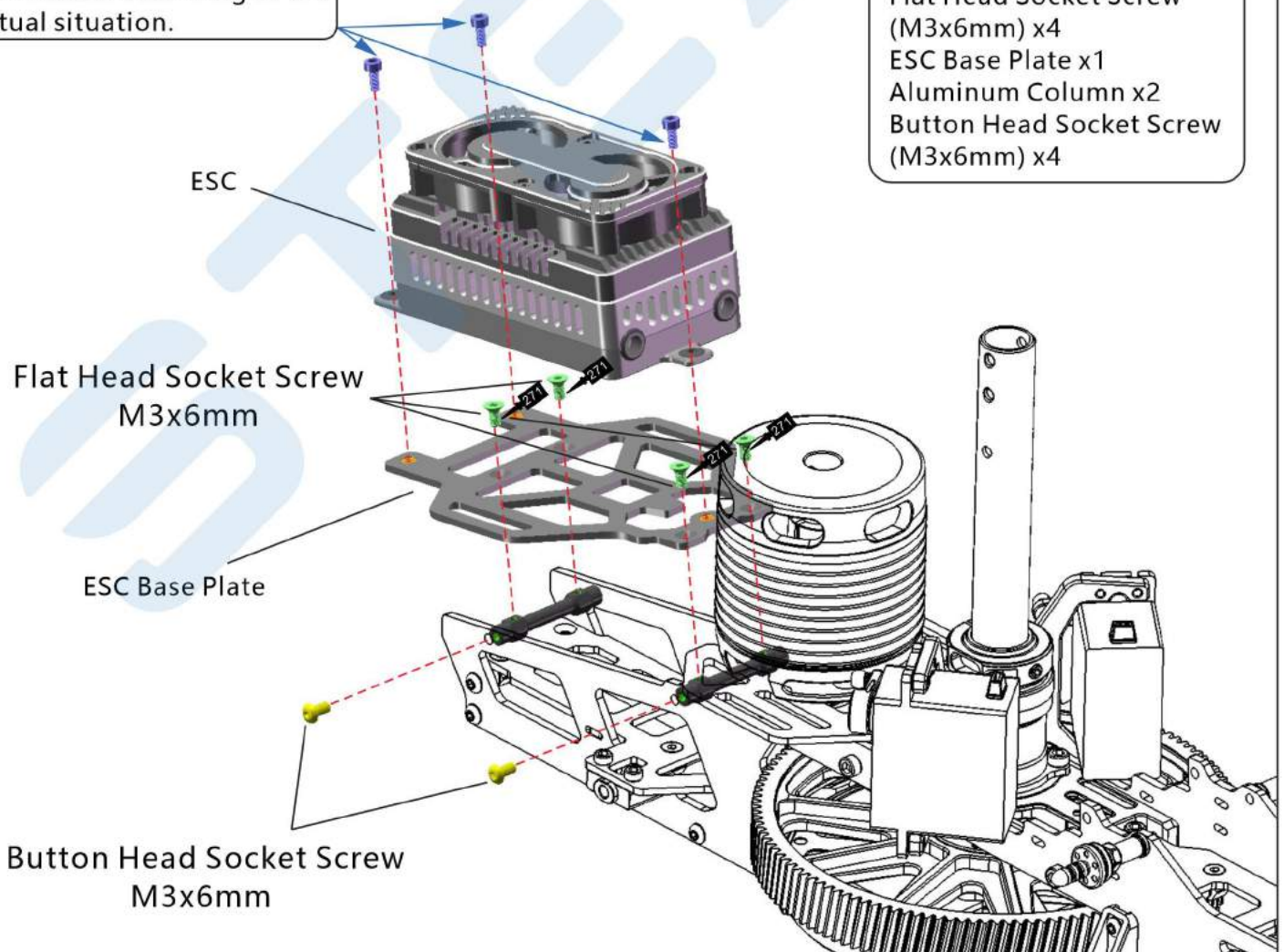

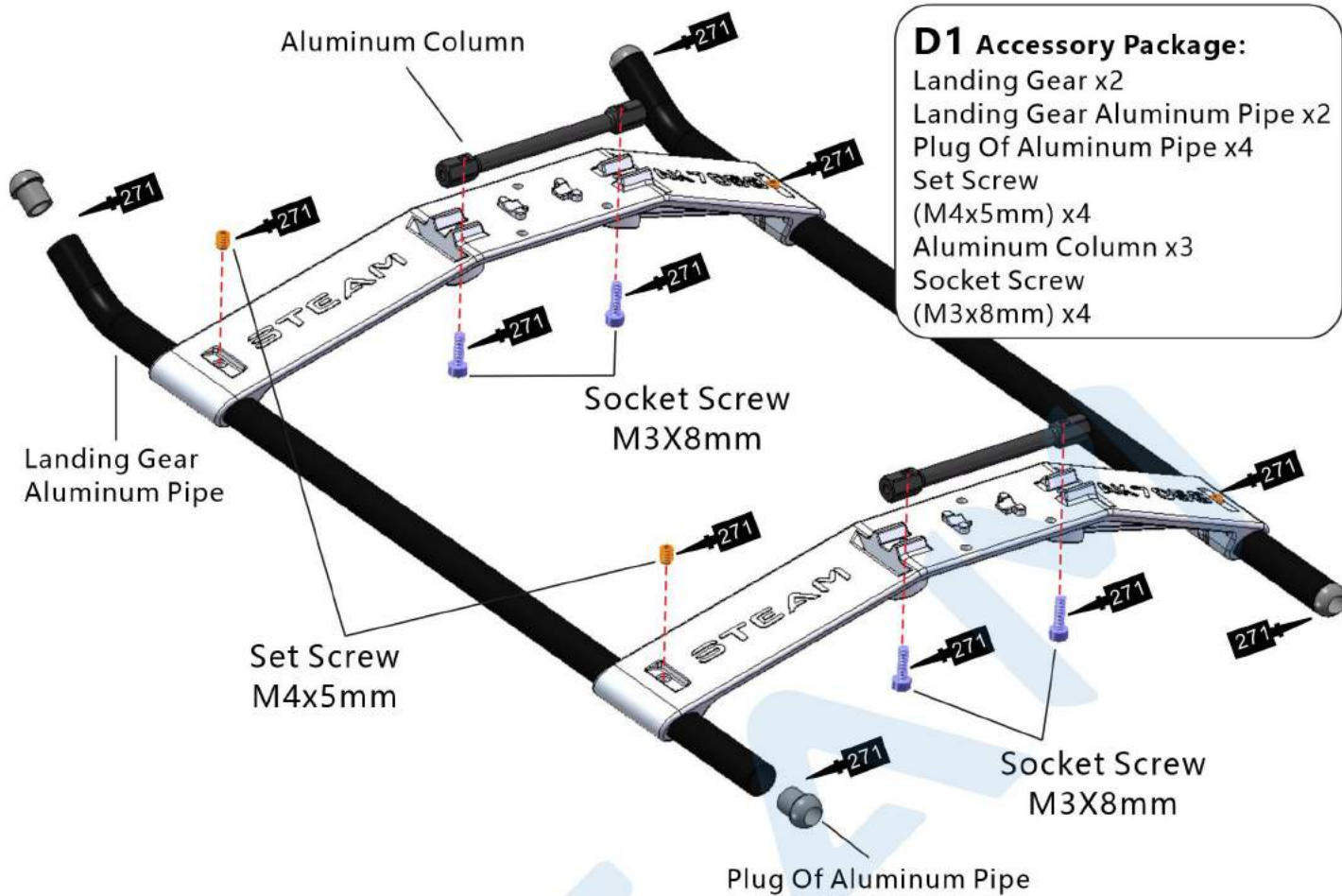

D1 Accessory Package:
 Landing Gear x2
 Landing Gear Aluminum Pipe x2
 Plug Of Aluminum Pipe x4
 Set Screw (M4x5mm) x4
 Aluminum Column x3
 Socket Screw (M3x8mm) x4

B5 Accessory Package:
 Battery Limiter x2
 Button Head Socket Screw (M2.5x6mm) x2
 Button Head Socket Screw (M2.5x8mm) x2
 Threaded Collar(M2.5) x2
 11T Protection Strip x2
 Battery Rubber Plug x2
 Button Head Socket Screw (M4x6mm) x4
 Socket Screw (M3x6mm) x8
 Spacer(M4) x4

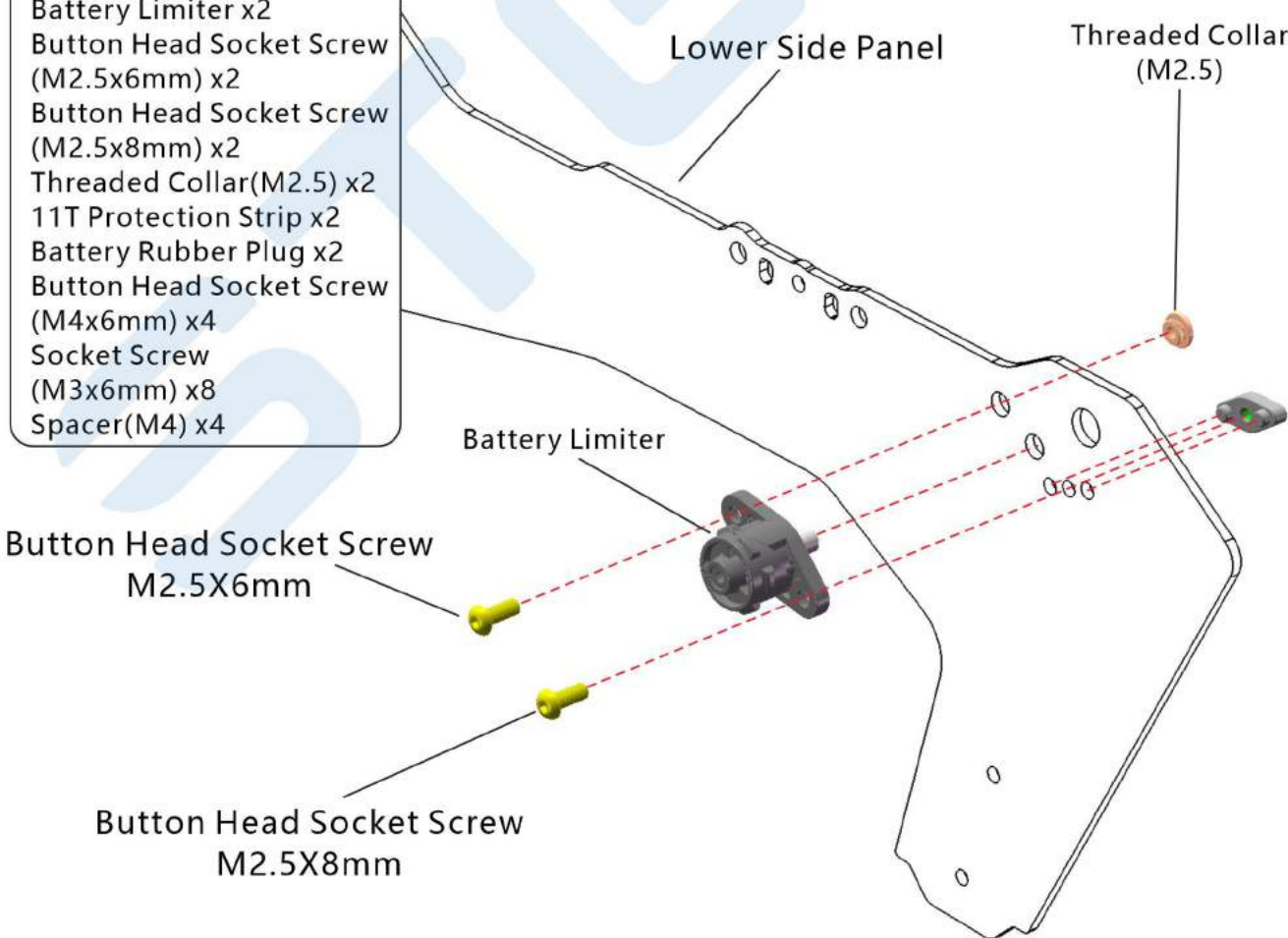

CAUTION 注意

After inserting the carbon plate,
cut along the dotted line.
插入碳板后, 请沿虚线剪开。

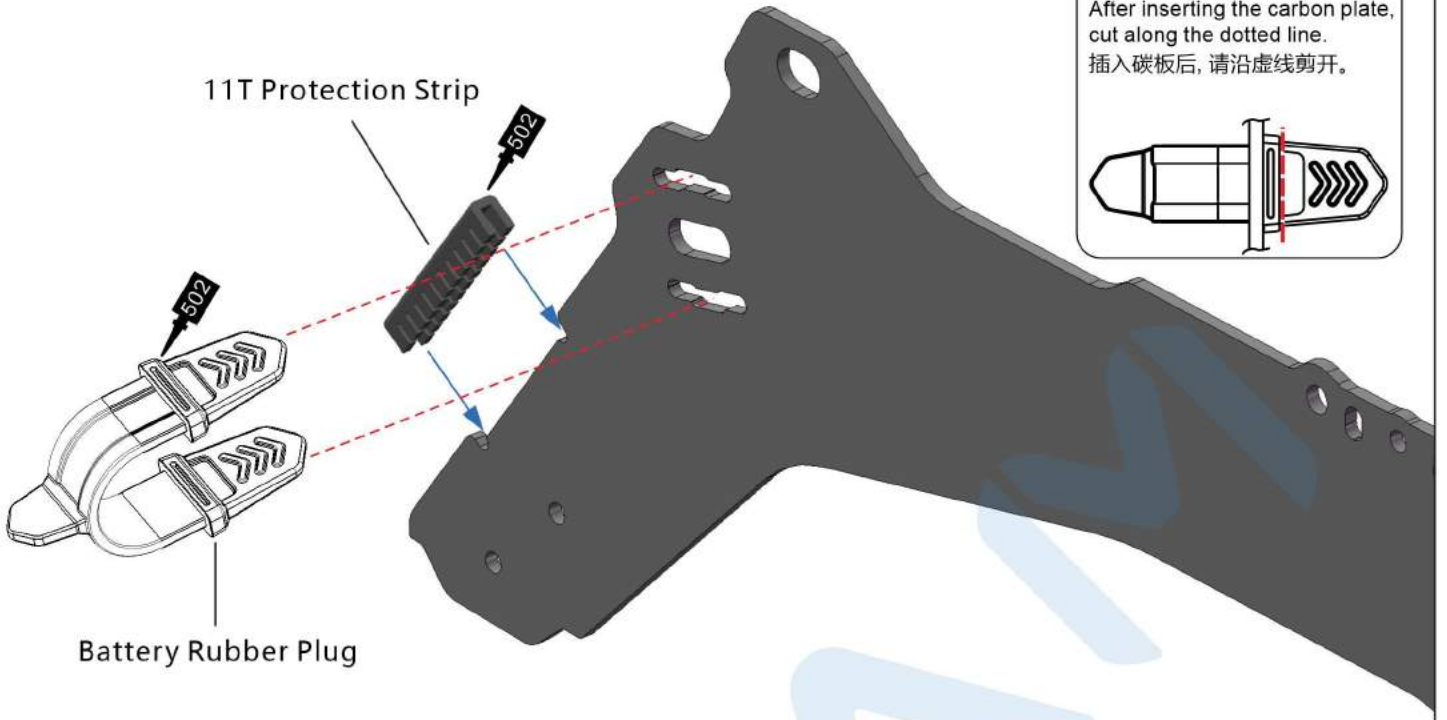
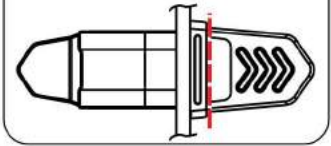

11T Protection Strip

502

502

Battery Rubber Plug

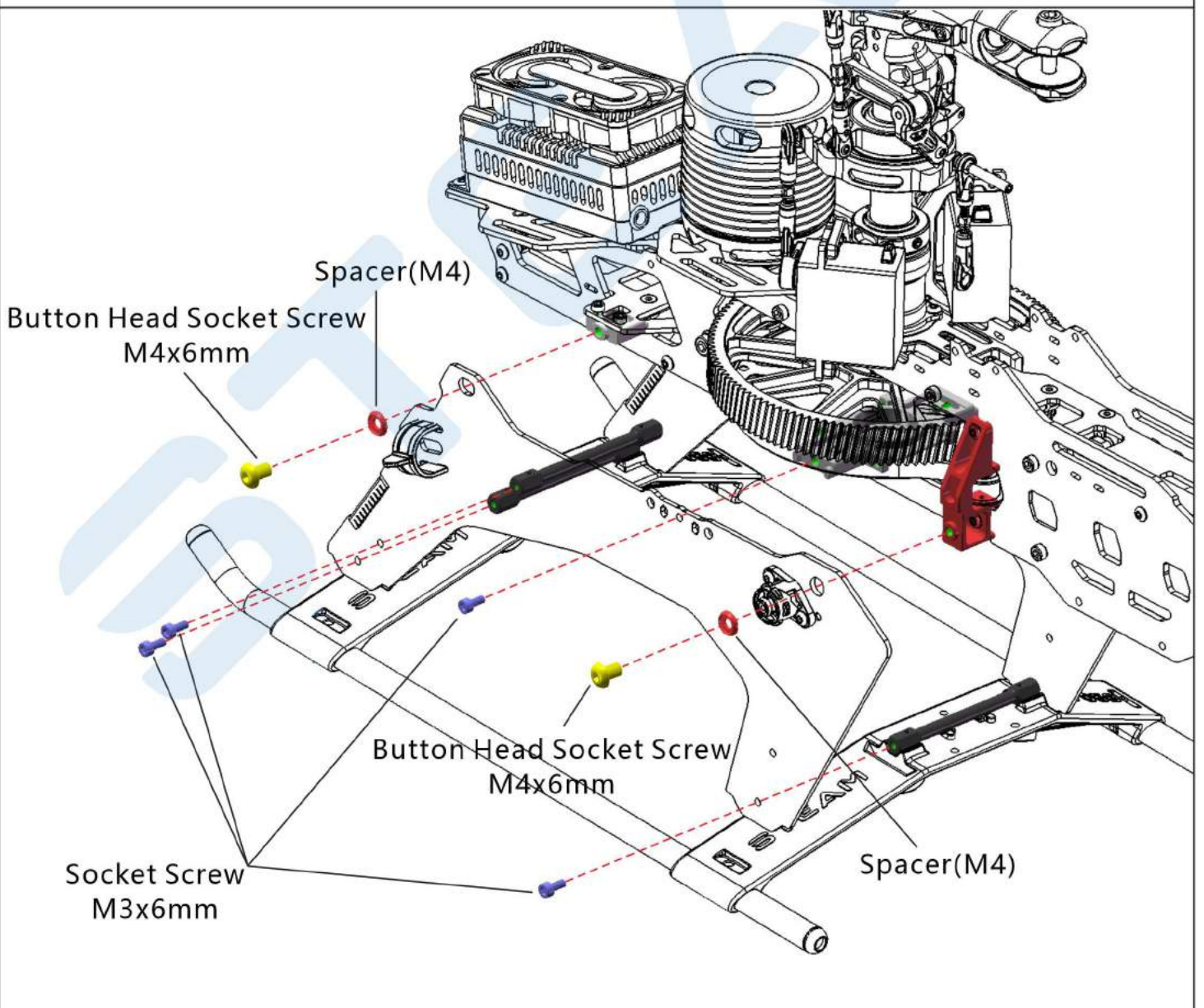

Spacer(M4)

Button Head Socket Screw
M4x6mm

Button Head Socket Screw
M4x6mm

Socket Screw
M3x6mm

Spacer(M4)

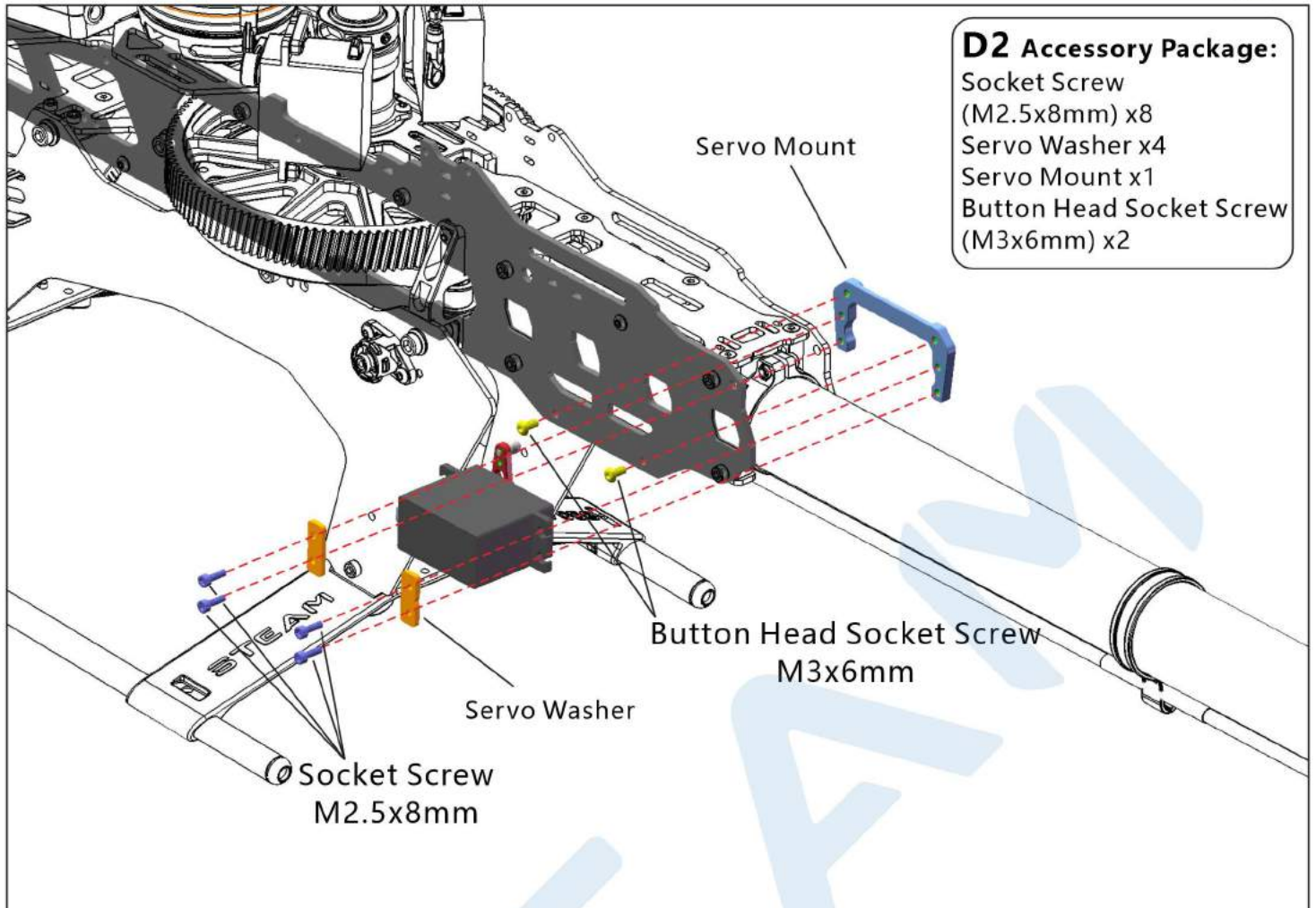

D2 Accessory Package:

- Socket Screw (M2.5x8mm) x8
- Servo Washer x4
- Servo Mount x1
- Button Head Socket Screw (M3x6mm) x2

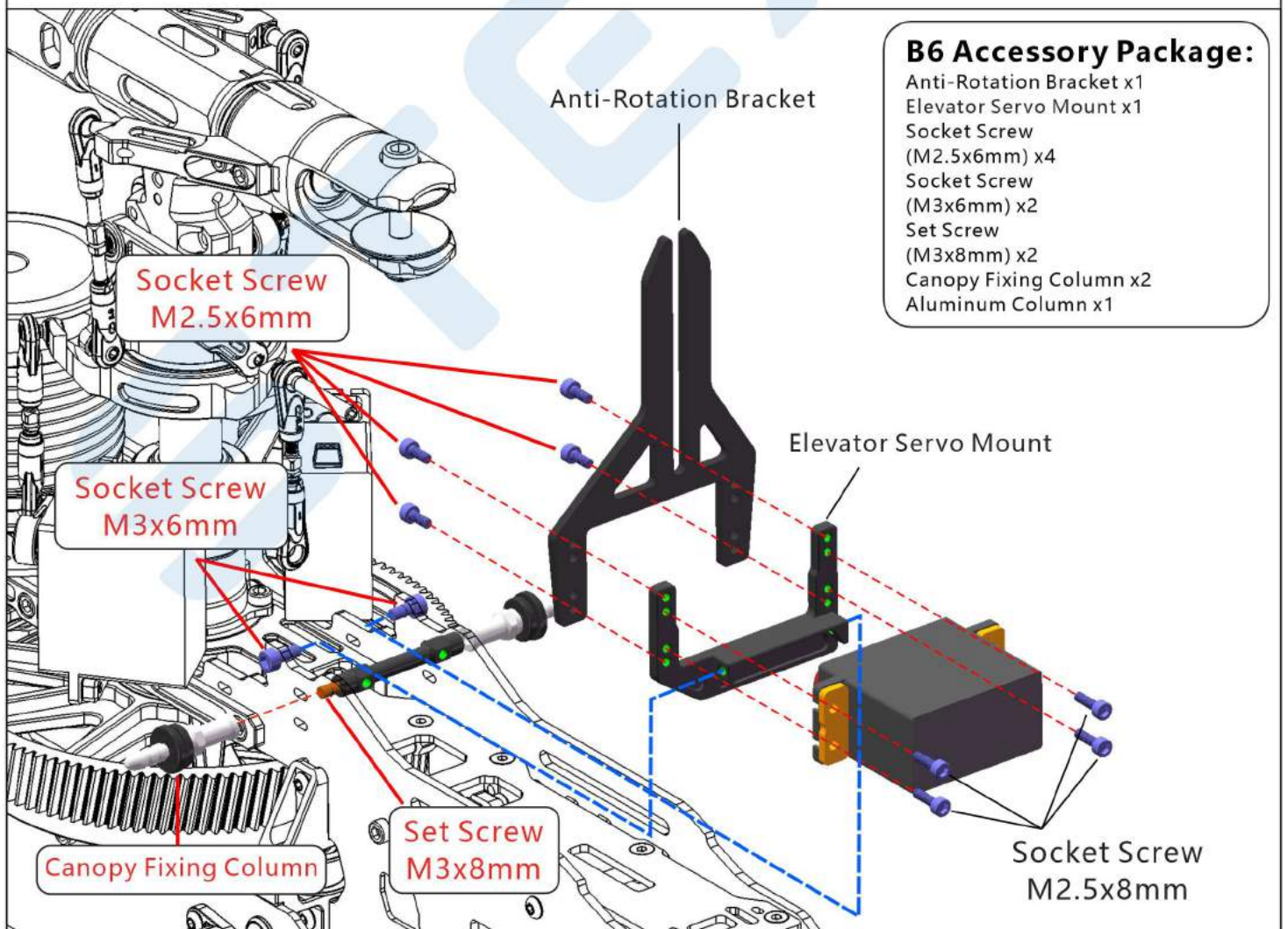

B6 Accessory Package:

- Anti-Rotation Bracket x1
- Elevator Servo Mount x1
- Socket Screw (M2.5x6mm) x4
- Socket Screw (M3x6mm) x2
- Set Screw (M3x8mm) x2
- Canopy Fixing Column x2
- Aluminum Column x1

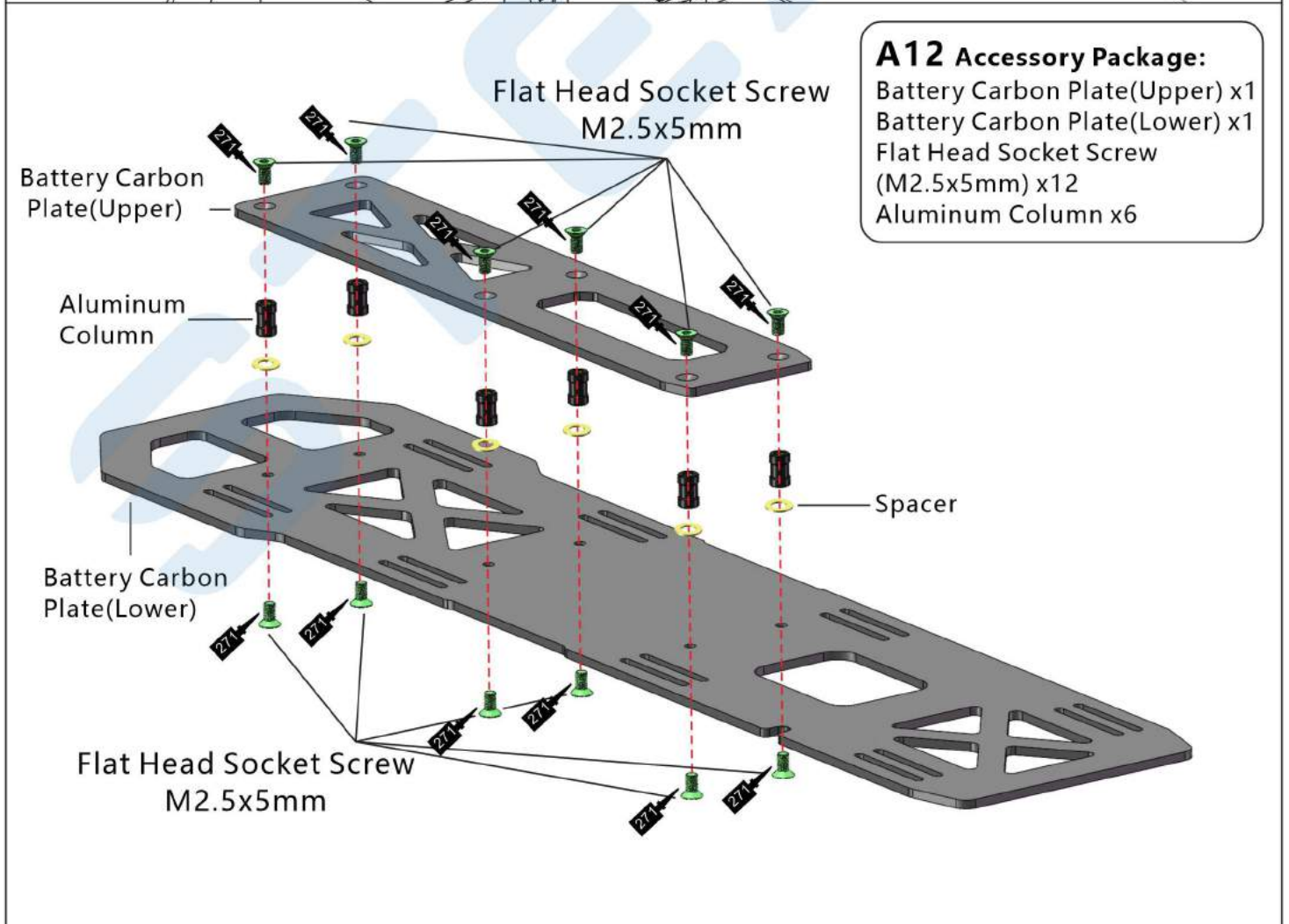
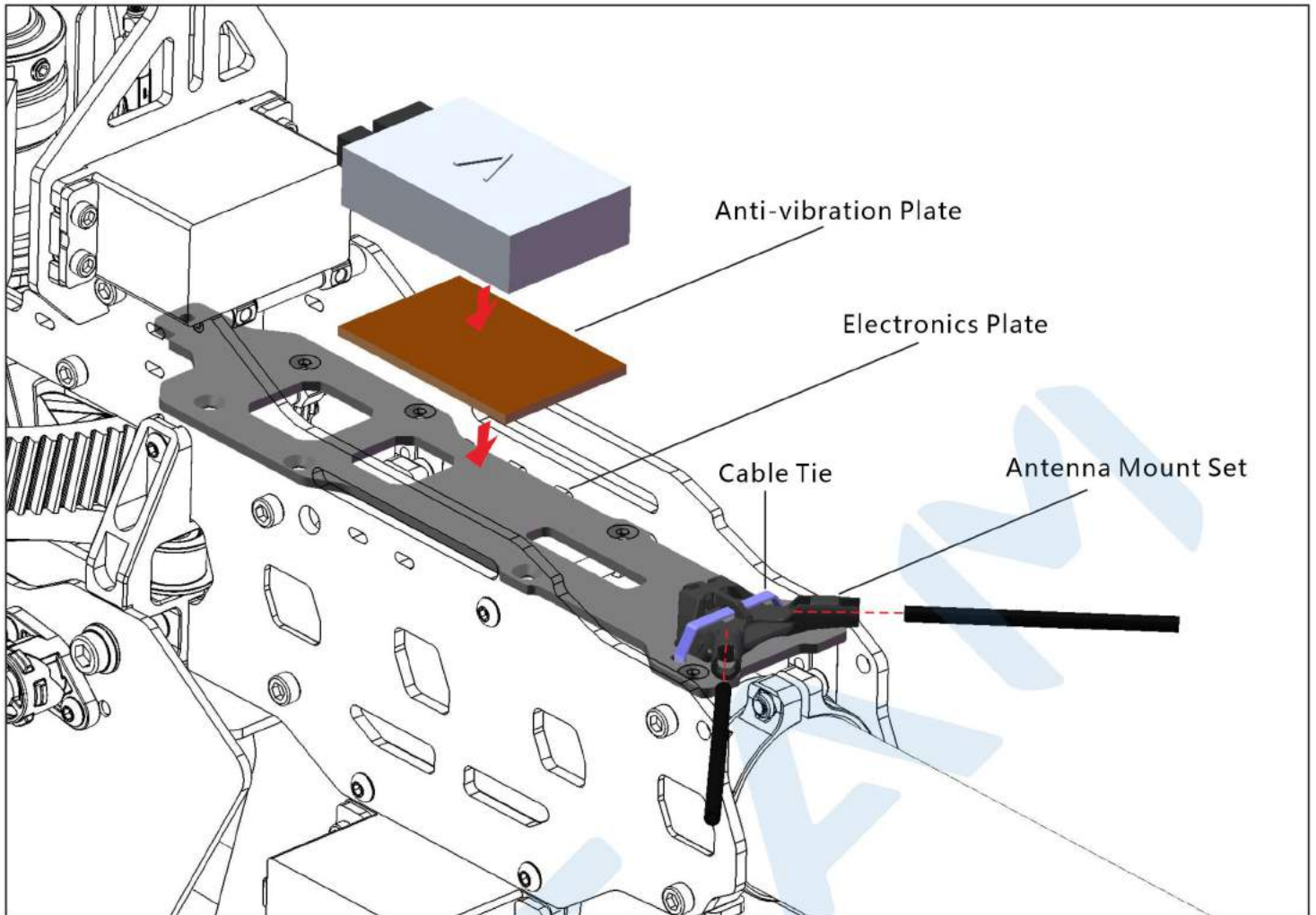

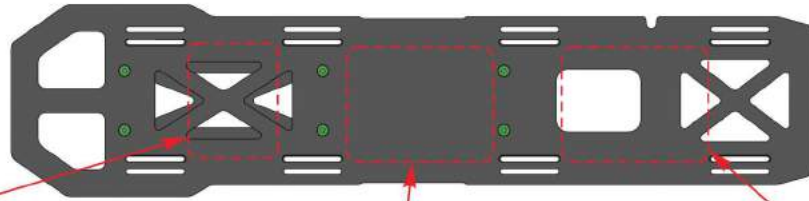

Slip-Proof Sticker
(sold separately)

Slip-Proof Sticker
(sold separately)

Slip-Proof Sticker
(sold separately)

make the anti-slip sticker to the battery fixing plate with glue.
用胶水将止滑贴粘在电池固定板上。

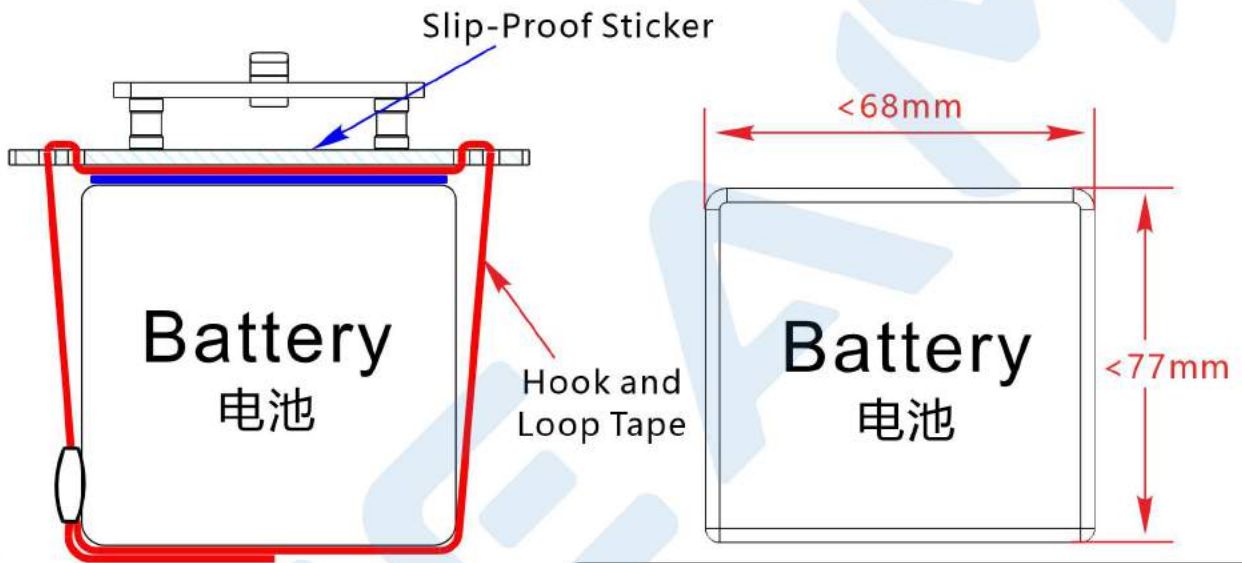

Please not tighten the tie, until finished installtion,make sure the center of gravity and then fix.
先不要把魔术带拉紧，等最后安装完成，确定重心再固定。

The center of gravity of the helicopter has the spindle seat as the center point.Adjust the front and rear mounting positions of the battery to determine the center of gravity of the helicopter.
直升机的重心以主轴座作为中心点。调节电池前后的安装位置，以此确定直升机的重心。

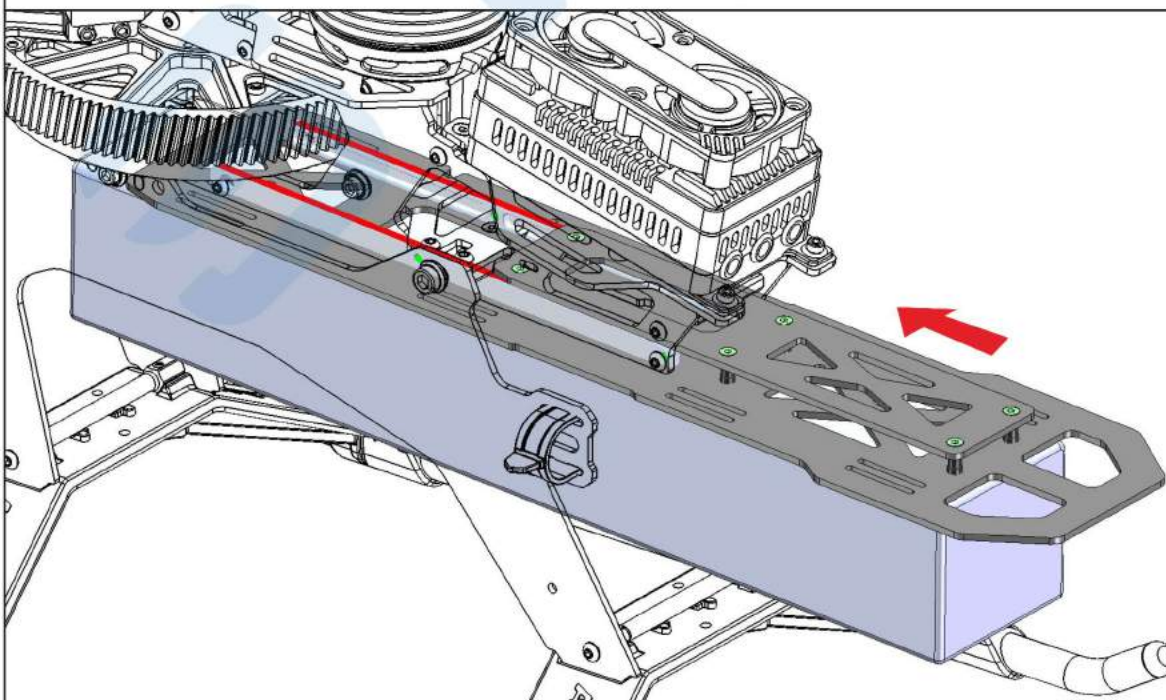

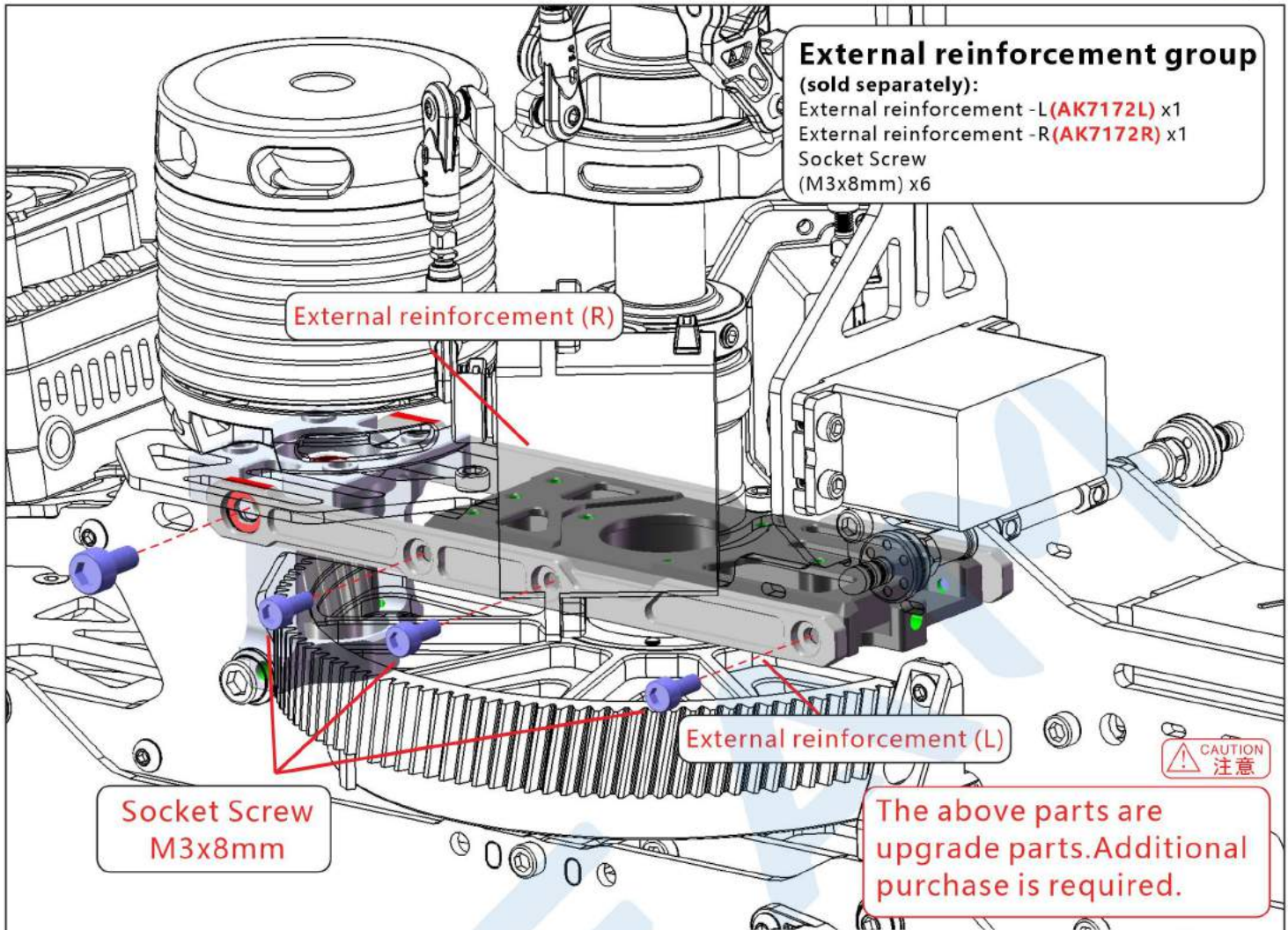

External reinforcement group

(sold separately):
 External reinforcement -L(AK7172L) x1
 External reinforcement -R(AK7172R) x1
 Socket Screw
 (M3x8mm) x6

External reinforcement (R)

External reinforcement (L)

Socket Screw
 M3x8mm

The above parts are upgrade parts. Additional purchase is required.

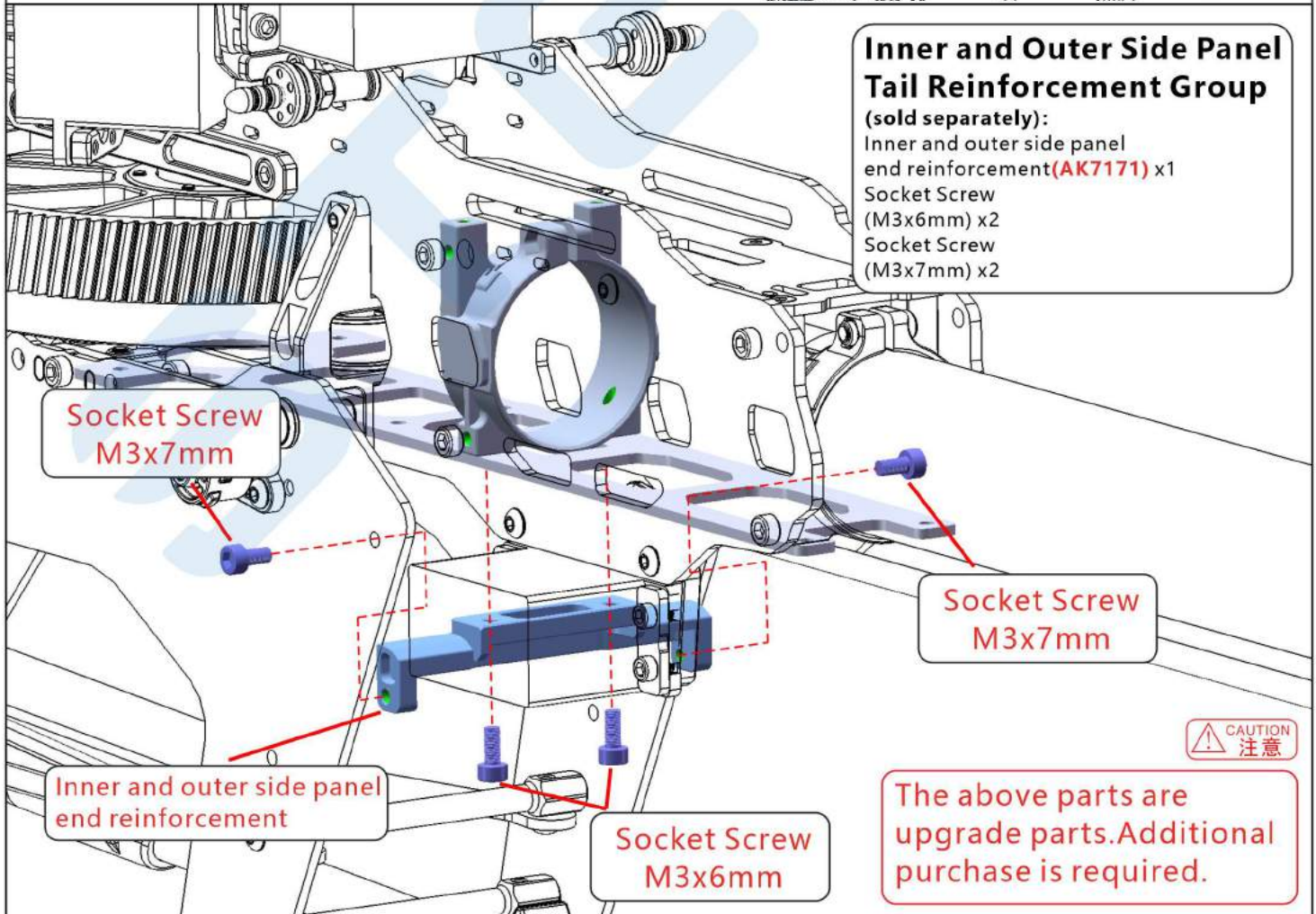

Inner and Outer Side Panel Tail Reinforcement Group

(sold separately):
 Inner and outer side panel
 end reinforcement(AK7171) x1
 Socket Screw
 (M3x6mm) x2
 Socket Screw
 (M3x7mm) x2

Socket Screw
 M3x7mm

Socket Screw
 M3x7mm

Inner and outer side panel
 end reinforcement

Socket Screw
 M3x6mm

The above parts are upgrade parts. Additional purchase is required.



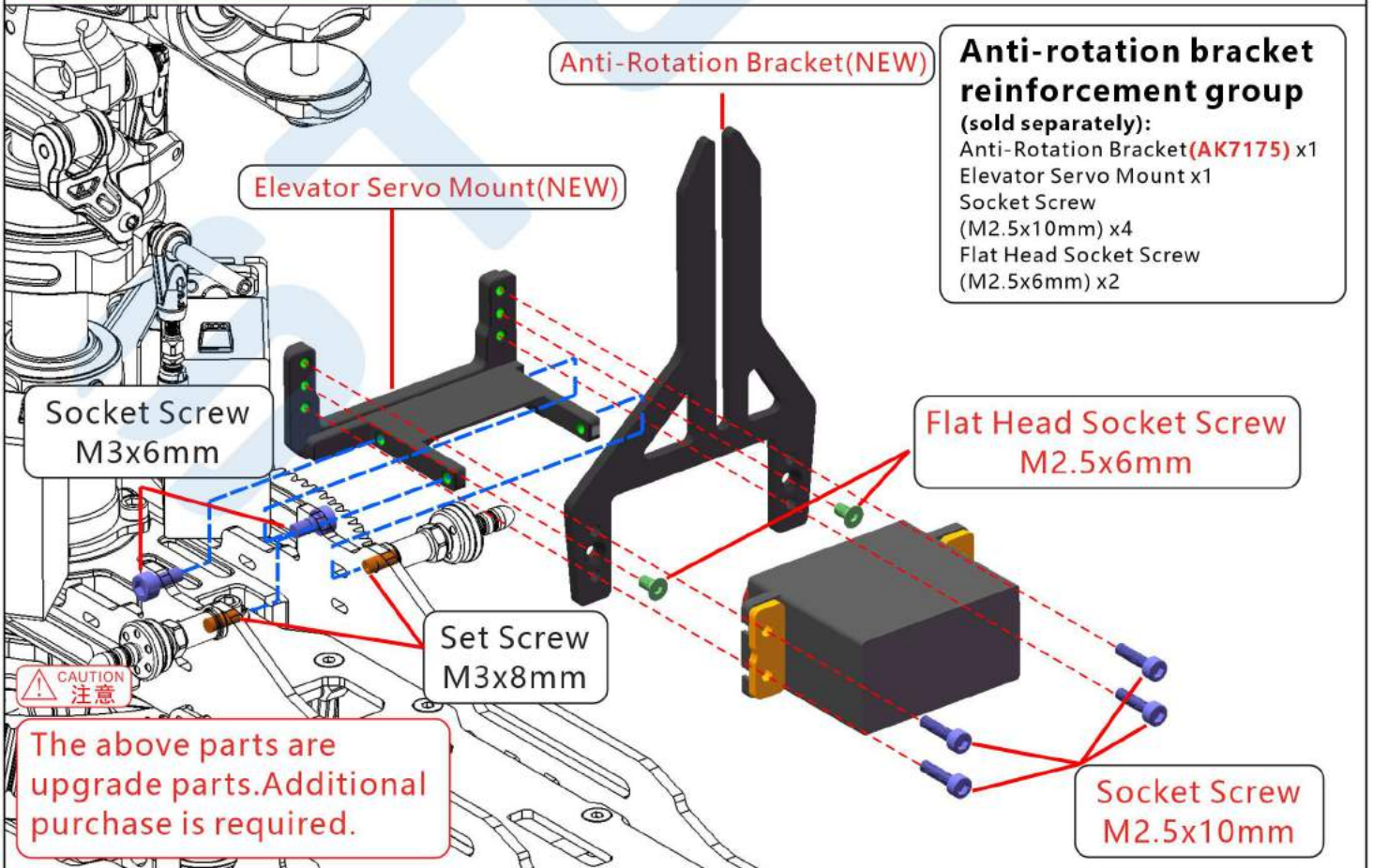
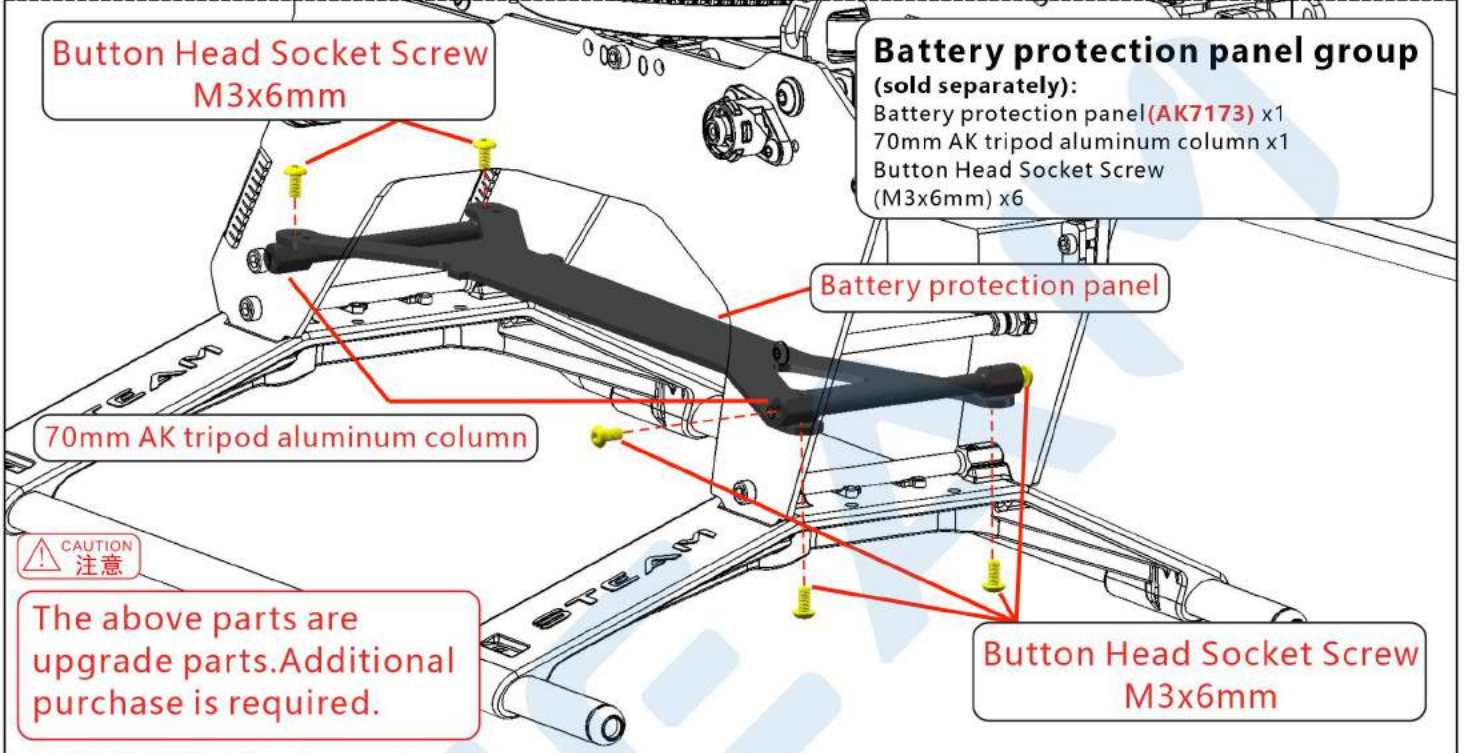
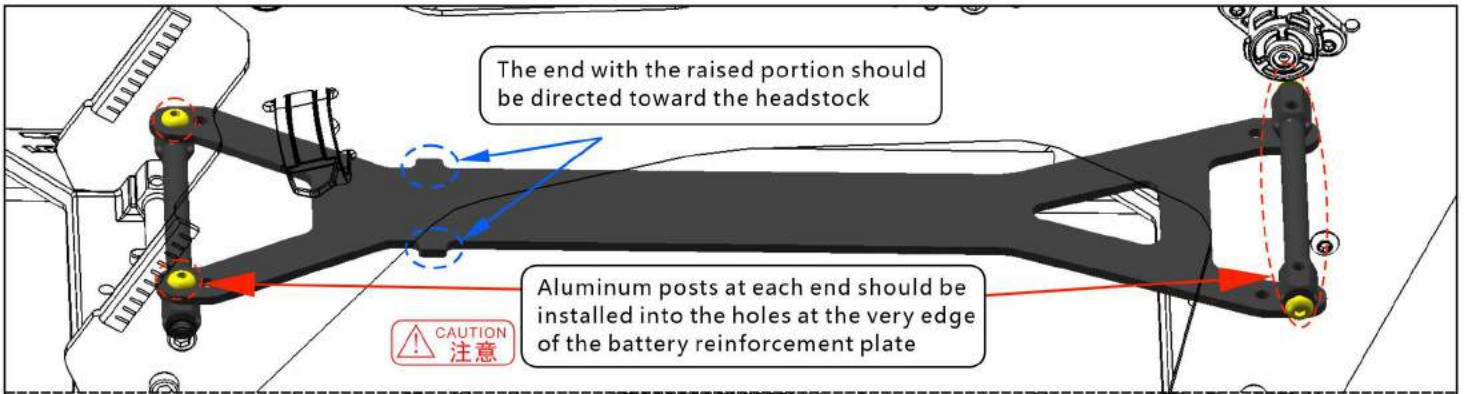

ADDITIONAL TOOLS REQUIRED FOR ASSEMBLY

自备工具

STEAM



Ball Head Knife Set
球头刀套装/HZ037

STEAM



Ball nose pliers
球头钳/HZ085

STEAM



Machine Adjustment Tool Set
调机工具套装/HOT100000

STEAM



Electronic Pitch Gauge
电子螺距尺/HOT100019

STEAM



Bearing Glue
轴承胶/K10291C

STEAM



Screw Glue
螺丝胶/K10291A

STEAM



OIL
锂基脂/HOT00009

STEAM



Landing gear damper
脚架垫圈(红)
BZ10-1

Landing gear damper
脚架垫圈(黄)
BZ10-2

Landing gear damper
脚架垫圈(绿)
BZ10-3

ADDITIONAL TOOLS REQUIRED FOR ASSEMBLY

自备工具

STEAM



Screwdriver
对拧螺丝刀/HZ022

STEAM



Colorful Titanium Plated
Screwdriver Set/Four packs
多彩镀钛螺丝刀套装/四把装 HZ024

STEAM



Grease
橡胶润滑脂/HOT00006

STEAM



Non-slip battery cable tie
防滑电池扎带/HOB00002

STEAM



Maintenance towel
维修毛巾/BG61549A

STEAM



Swashplate one hole Servo Horn
/25T Fragile M2.5
斜盘单孔舵机臂/ H7080
25T易碎M2.5(18MM)

Choose one of these and
buy another set of three
选择其中一款另购三组

STEAM



Swashplate double hole servo horn
/25T fragile M2.5
斜盘双孔舵机臂/H7083
25T易碎M2.5(14/18MM)

STEAM

Purchase another set
另购一组



Tail servo horn
锁尾舵机臂/H7088

	Problem 状况	Cause 原因	Solution 对策
Blade Tracking 双桨平衡	Tracking is Off 双桨	Pitch linkage rods are not even length. PITCH 连杆长度调整不均匀.	Adjust length of pitch linkage rods (A). 调整连杆 (A) 长度.
Hover 停悬	Headspeed too low or high. 主旋翼转速偏低或者偏高.	Excessive pitch high or low. 主旋翼的PITCH偏高或过低.	Adjust pitch linkAge rods(A) to reduce pitch by 4 to 5 degrees.Hovering headspeed should be around 1900RPM. 调整连杆(A)调低Pitch约+4~5度 (停悬时主旋翼需为约1900RPM).
		Hovering Throttle curve is too low or high. 停悬点油门曲线过低或过高.	Increase throttle curve at hovering point on transmitter(around 65%). 调停悬点油门曲线(约65%).
Oscillation during flight 飞行抖动	Helicopter Oscillation. 机身抖动.	Main shaft instal no vertical, Main shaft bear mount screws need to Cross tighten. 主轴安装不垂直, 主轴轴承座螺丝需要交叉拧紧.	
	Foward/aft oscillation when elevator is applied. 升降舵打舵动作时, 机体前后抖动.	Elevator gyro gain too high. 升降舵陀螺感度偏高, 产生追踪现象.	Turn the ELE gaina dial on servo counterclockwise, 10degrees at a time until oscillation is eliminated. 逆时针调整舵机上的升降舵感度调整旋钮, 以每次调整约10度方式, 调整至适当位置.
	Helicopter front bobbles (nods) during foward flight. 直线飞行时, 机头点头.	Worn servo, or slack in control links. 伺服器老化控制结构有虚位.	Replace servo, ball link, or linkage balls. 更换伺服器, 连杆头, 球头.
	Left/right oscillation when aileron is applied. 副翼打舵动作时, 机体左右抖动. Elevator input causes helicopter to drift. 升降舵动作漂移.	Aileron gyro gain too high. 副翼陀螺感度偏高产生追踪现象.	Turn the ALL gain dial on servo counterclockwise, 10degrees at a time until oscillation is eliminated. 逆时针调整舵机上的副翼感度调整旋钮, 以每次调整约10度方式, 调整至适当位置.
Helicopter Head Up 直升机机头会上扬	Helicopter head up during fast flight. 快速飞行时直升机机头会上扬.	Gyro pitch gain too low. 俯仰 (Pitch) 感度不足.	Increase the pitch gain. 请调高俯仰(Pitch) 感度.
		Elevator trim not centered. 十字盘升降舵中立点不对.	Check if helicopter is tilting backwards during hover. 请测试悬停时, 直升机中立点是否朝后.
Rudder Response 尾舵反应	Drifting of tail occurs during hovering, or delay of rudder response when centering rudder stick. 停悬时尾翼向某一边偏移, 或拨动方向舵并回复到中立点时, 尾翼产生延迟, 无法停顿在所控制位置上.	Rudder neutral pointimproperly set. 尾中立点设定不当. Rudder gyro gain too low. 尾舵陀螺仪感度偏低.	Reset rudder neutral point. 重设尾中立点. Increase rudder gyro gain. 增加尾舵陀螺仪感度.
	Tail oscillates (hunting, or wags) at hover or full throttle. 停悬或全油门时尾翼左右来回摇摆.	Rudder gyro gain too high. 尾舵陀螺仪感度偏高.	Reduce rudder gyro gain. 降低尾舵陀螺仪感度.
If the problem is still there even after tried above, stop flying and contact with your seller. 在做完以上调整后, 仍然无法改善情况时, 应立即停止飞行并联络你的经销商.			

Specifications & Equipment/规格配置

Length/机身长: 1360mm

Height/机身高: 357mm

Main Blade Length/主旋翼长: 690~715mm

Tail Rotor Length/尾旋翼长: 106~116mm
(With rotor and electronics, not include battery / 包含桨和电子设备,不包含电池)Approx. 3500g

Recommended Motors/马达建议选用:

4530/4725/4730/5024

Number of revolutions per minute/转速:

510KV-535KV

Electronic Governor/电子调速器: 160A-260A

Two Kinds Of Rotor Arm Cause Angular Variation Of Rotor 两种夹座臂引起旋翼角度的变化		
Servo Rotation Angle 伺服器旋转角度	Main Rotor Holder Arm (Length) 主旋翼夹座臂(长度)	Main Rotor Rotation Angle 主旋翼旋转角度
15°	31mm	17.4°
	32.5mm	18.24°

Main Ratio Parameter 主传动比参数		
Drive Gear Ratio 主齿轮传动比	9.77	9.07
Main Drive Pulley 主齿轮	127T	127T
Motor Drive Pulley 马达齿轮	13T	14T

Tail Ratio Parameter 尾传动比参数		
Drive Gear Ratio 尾齿轮传动比	5.0	4.8
Autorotation Tail Drive Pulley 尾驱动主齿轮	120T	120T
Tail Drive Pulley 尾齿轮	24T	25T

