



888-577-5218

www.KYMIndustries.com

Tarps and Tarp Systems for Dumpsters, Roll Offs, Landfill Covers, and Custom Applications!

# BOX DETAIL SHEET FOR GRAIN CARTS AND GRAVITY WAGONS

ALL CUSTOM MADE TARPS ARE NON- RETURNABLE. CORRECT MEASUREMENTS ARE ESSENTIAL FOR PROPER FIT OF A TARP. PLEASE PROVIDE ALL REQUESTED INFORMATION. ALWAYS USE THE ACTUAL MEASUREMENTS OF THE BOX.

## CONTACT INFORMATION

NAME \_\_\_\_\_  
 ADDRESS \_\_\_\_\_  
 EMAIL \_\_\_\_\_  
 CITY \_\_\_\_\_ STATE \_\_\_\_\_ ZIP \_\_\_\_\_  
 PHONE \_\_\_\_\_ FAX \_\_\_\_\_  
 BOX/TRAILER MAKE \_\_\_\_\_  
 MODEL \_\_\_\_\_ YEAR \_\_\_\_\_

## BOX DIMENSIONS

A \_\_\_\_\_ UPPER OUTSIDE BOX LENGTH  
 B \_\_\_\_\_ UPPER OUTSIDE BOX WIDTH  
 Front \_\_\_\_\_ Center \_\_\_\_\_ Rear \_\_\_\_\_  
 N \_\_\_\_\_ TOP RAIL WIDTH  
 U \_\_\_\_\_ INSIDE BOX WIDTH  
 X \_\_\_\_\_ UPPER OUTSIDE BOX HEIGHT

LIP IN  LIP OUT

REAR CONFIGURATION Must answer this

VERTICAL  SLOPED

BOX EXTENSION STYLE See Figures 1 and 2

FLAT  SLANTED  FLAT W/ANGLE  
 SLANTED W/ANGLE  SLANTED W/OVERHANG  
 SLANTED W/OVERHANG AND ANGLE

BOX EXTENSION DIMENSIONS

B4 \_\_\_\_\_ EXTENSION WIDTH  
 X1 \_\_\_\_\_ EXTENSION HEIGHT DRIVER SIDE  
 X2 \_\_\_\_\_ EXTENSION HEIGHT PASSENGER SIDE  
 X3 \_\_\_\_\_ LOWER EXTENSION ANGLE

TARP COLOR(S) \_\_\_\_\_

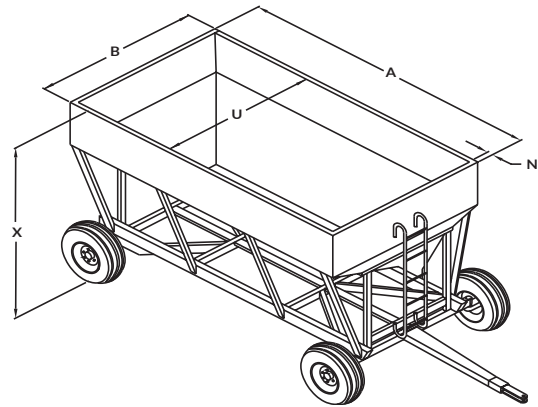
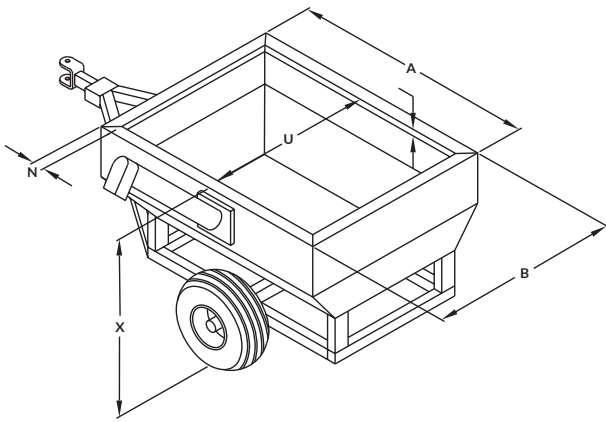
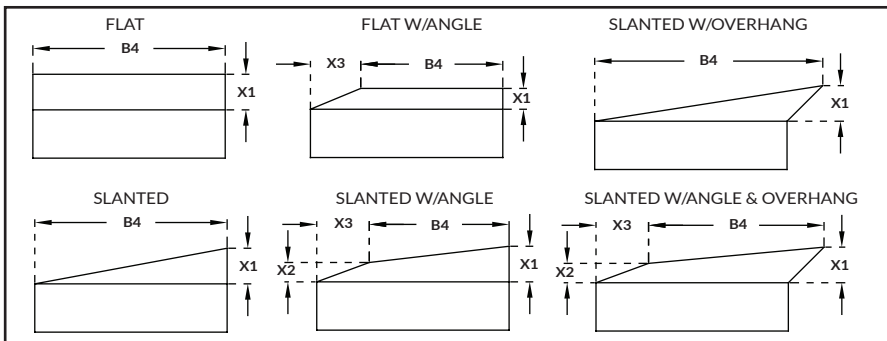
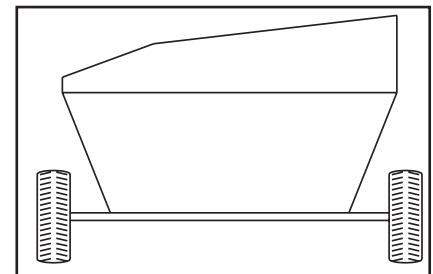

FIGURE 1



NOTE: Flat caps can ONLY be used on a SLANTED extension (see above), and the side walls MUST BE VERTICAL.

FIGURE 2



NOTE: If ordering galvanized caps, make sure box is flat across top. Figure 2 shows a box with an uneven angle across the top. Galvanized caps will NOT fit this box; you must order fabric caps instead.

PRINTED: \_\_\_\_\_

SIGNATURE: \_\_\_\_\_

DATE: \_\_\_\_\_