



888-577-5218

www.KYMindustries.com

Tarps and Tarp Systems for Dumpsters, Roll Offs, Landfill Covers, and Custom Applications!

BOX DETAIL SHEET FOR CABLE FOR FARM BODIES

ALL CUSTOM MADE TARPS ARE NON- RETURNABLE. CORRECT MEASUREMENTS ARE ESSENTIAL FOR PROPER FIT OF A TARP. PLEASE PROVIDE ALL REQUESTED INFORMATION. ALWAYS USE THE ACTUAL MEASUREMENTS OF THE BOX.

CONTACT INFORMATION

NAME _____
 ADDRESS _____
 EMAIL _____
 CITY _____ STATE _____ ZIP _____
 PHONE _____ FAX _____
 BOX/TRAILER MAKE _____
 MODEL _____ YEAR _____

BOX DIMENSIONS

A _____ UPPER BOX LENGTH
 B _____ UPPER BOX WIDTH
 N _____ TOP RAIL WIDTH
 U _____ INSIDE BOX WIDTH
 X _____ OUTSIDE BOX HEIGHT FROM GROUND
 TARP COLOR(S) _____

REPLACEMENT TARPS

TYPE OF TARP BEING REPLACED See Figure1 for outer hole distance

- CABLE W/CHANNEL
- OTHER W/CHANNEL OTHER BRAND _____
- OTHER W/RIVETS No. Rivets _____ Outer Hole Distance _____

_____ FINISHED SEWN TARP LENGTH

_____ FINISHED SEWN TARP WIDTH

TYPE OF CAP MEASURED See Figure 2

- FACE MOUNT TOP MOUNT

CR _____ END CAP RISE

CD _____ END CAP DEPTH Front _____ Rear _____

_____ OUTSIDE END CAP TO END CAP LENGTH

_____ BOX WIDTH

_____ BOX LENGTH

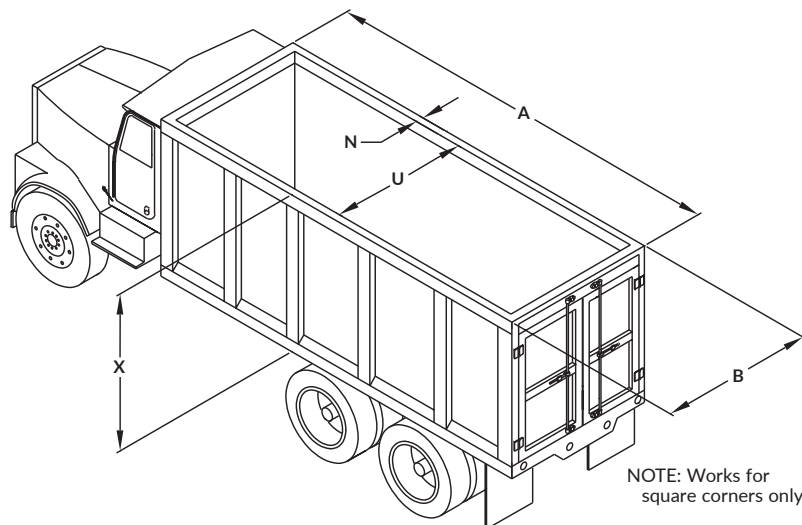

FIGURE 1

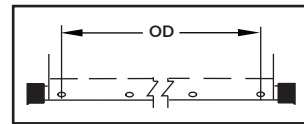
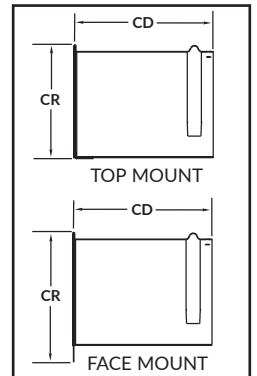

FIGURE 2



PRINTED: _____

SIGNATURE: _____

DATE: _____