



888-577-5218
 Tarps and Tarp Systems for Dumpsters, Roll Offs, Landfill Covers,
 and Custom Applications!

www.KYMindustries.com

BOX DETAIL SHEET FOR DUMP BODIES

ALL TARPS ARE CUSTOM-MADE TO ORDER AND ARE NON-RETURNABLE. CORRECT PHYSICAL MEASUREMENTS ARE ESSENTIAL FOR PROPER TARP FIT. PROVIDE ALL REQUESTED INFORMATION OR YOUR ORDER MAY BE DELAYED. DO NOT USE UNIVERSAL BOX SIZES. ALWAYS USE ACTUAL MEASUREMENTS. BOX SIZE AND FINISHED TARP SIZE ARE NOT THE SAME.

CONTACT INFORMATION

NAME _____ CITY _____ STATE _____ ZIP _____
 ADDRESS _____ PHONE _____ FAX _____
 EMAIL _____ BOX/TRAILER MAKE _____

BOX DIMENSIONS

A _____ UPPER BOX LENGTH
 B _____ UPPER BOX WIDTH
 J _____ UPPER SHIELD WIDTH
 N _____ TOP RAIL WIDTH
 U _____ INSIDE BOX WIDTH
 K _____ LOWER SHIELD WIDTH
 X _____ BOX HEIGHT
 U1 _____ PLANK-TO-PLANK WIDTH
 Front _____ Center _____ Rear _____
 H _____ SHIELD HEIGHT

CORNER CONFIGURATION Must select one - see Figure 1

SQUARE DIAGONAL RADIUS

C _____ OUTSIDE CORNER RADIUS
 E _____ FLAT ACROSS FRONT
 V _____ FLAT ACROSS DIAGONAL
 W _____ DIAGONAL DEPTH

CAB SHIELD STYLE See Figures 3 and 4

FLAT RAISED WITHOUT CAB SHIELD

A _____ UPPER BOX LENGTH AJ _____ CAB GUARD DEPTH
 AC _____ REAR BOW DEPTH Z _____ CAB GUARD HEIGHT
 O _____ TOP RAIL DROP Front _____ Rear _____

REAR DUMP STYLE See Figure 6

OVERSLUNG HINGE GATE COMBO DOOR HINGE GATE
 HIGH POWER LIFT GATE RAISED HINGE GATE

AF _____ HINGE DEPTH AK _____ HINGE HEIGHT
 B _____ BOX WIDTH/REAR

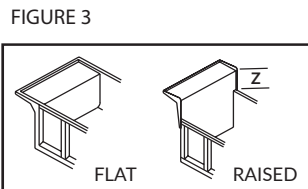
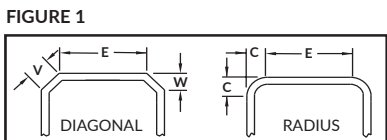
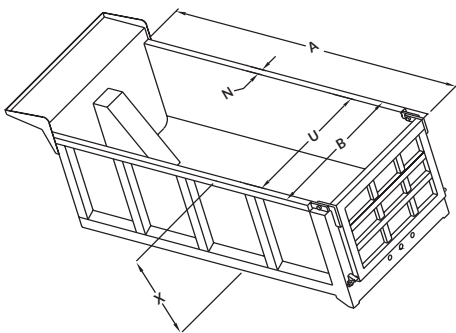
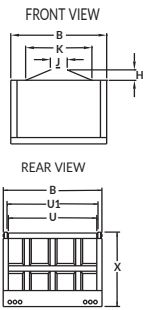
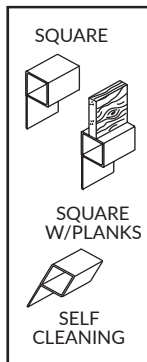

FIGURE 2



TARP RAIL STYLE See Figure 2

SQUARE
 SELF CLEANING
 SQUARE W/PLANKS*

Are planks flush with outside of top rail?

Y / N (Circle one)

TARP WEIGHT

18 OZ. 22 OZ.

TARP COLOR(S) _____

FRONT BODY STYLE See Figure 5

1-SIDE/CUT-OUT SHIELD 3/4 RAISED SHIELD
 TAPERED CAB SHIELD FULL CAB SHIELD

AG _____ CAB GUARD WIDTH H _____ SHIELD HEIGHT
 AH _____ INSIDE CAB GUARD WIDTH

AJ _____ CAB GUARD DEPTH J _____ UPPER SHIELD WIDTH
 B _____ UPPER BOX WIDTH Z _____ CAB GUARD HEIGHT

FIGURE 4

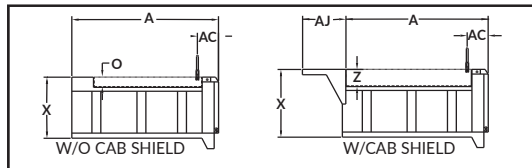

FIGURE 5

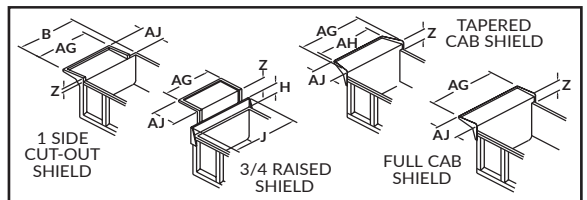
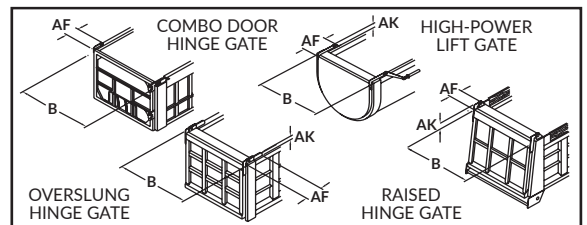

FIGURE 6



Signature _____