

X ROCKER GAMING BUNK BED

IMPORTANT – READ CAREFULLY – RETAIN FOR FUTURE REFERENCE

2110401

XRocker®

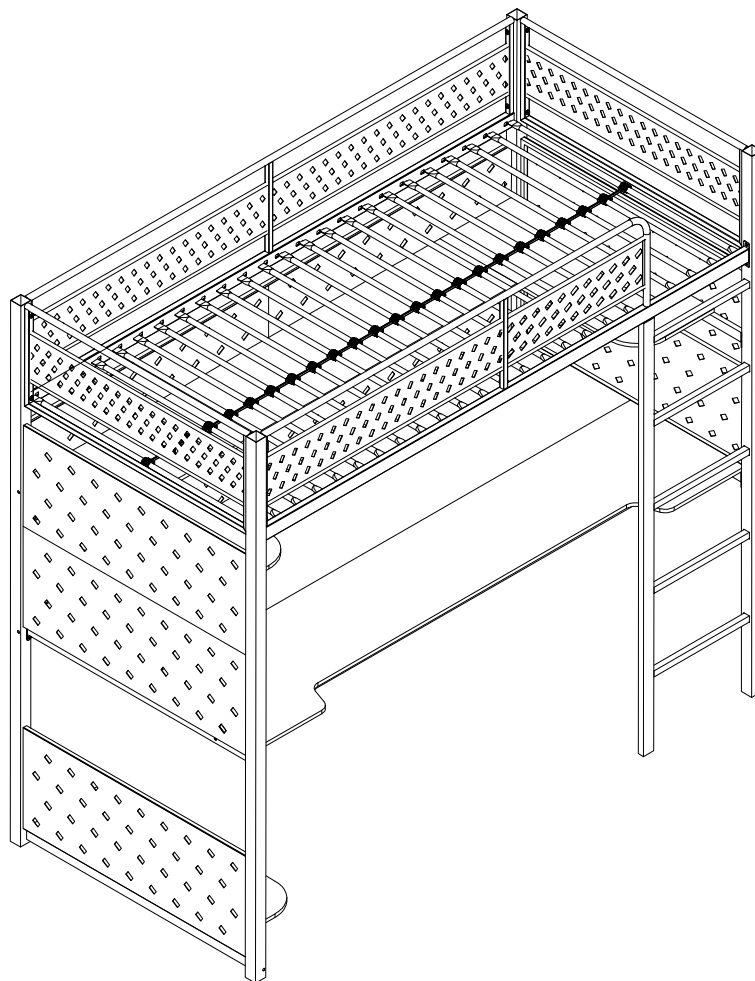

Dimensions

Width - 77.6in

Depth - 41.3in

Height - 72in

NEED HELP?

EMAIL: SUPPORT@XROCKERGAMING.COM

BESOIN D'AIDE?

COURRIEL: SUPPORT@XROCKERGAMING.COM

¿NECESITAS AYUDA?

CORREO ELECTRÓNICO: SUPPORT@XROCKERGAMING.COM

IMPORTANT: You must Keep your original retail receipt as proof of purchase.



Safety and Care Advice

Read Before Beginning Assembly

- Call 866-969-2603 if you need assistance.
- Work in a spacious area and near where the unit will be used, preferably on a carpet, or use a piece of the cardboard packaging to protect your floor and product.
- Recommended # of people needed for assembly: **2** (however it is always better to have an extra hand).
- Estimated assembly time is **3** hours.
- Make sure all parts are included. Most parts are labeled or stamped on the raw edge.
- Read each step carefully. It is very important that each step of the instructions is performed in the correct order. If these steps are not followed in sequence, assembly difficulties will occur.

Caution

- This product is designed for home use and not intended for commercial use.
- This product contains small components. Please ensure that they are kept away from small children.
- Clean the product with a soft damp cloth. **DO NOT** use harsh chemicals or abrasive cleaners.
- Periodically check and ensure that the guardrail, ladder, and other components are in their proper position, free from damage, and that all connectors are tight.

Handy Hints

- Move your new furniture carefully, with two people lifting and carrying the unit to its new location.
- Your furniture can be disassembled and reassembled to move.
- Assemble all parts and bolts loosely during assembly, only once the product is complete should you fully tighten the bolts
- Regularly check and ensure that all bolts and fittings are tightened properly.



Safety and Care Advice

WARNINGS

- Follow the information on the warnings appearing on the upper bunk end structure and on the carton. Do not remove warning label from bed.
- Always use the recommended size mattresses or mattress supports, or both, to help prevent the likelihood of entrapment or falls.
- Use only a twin mattress which is **74" - 75"** long and **37½" - 38½"** wide on upper bunk.
- Ensure thickness of mattress on upper bunk is greater than 4" and that it does not exceed 6".
- Surface of mattress must be at least 5" (127 mm) below the upper edge of guardrails.
- Do not allow children under 6 years of age to use the upper bunk.
- Do not allow horseplay on or under the bed and prohibit jumping on the bed.
- Prohibit more than one person on upper bunk.
- Always use the ladder for entering and leaving the upper bunk.
- Do not use substitute parts. Contact the manufacturer or dealer for replacement parts.
- Use of a night light may provide added safety precaution for a child using the upper bunk.
- Always use guardrails on both long sides of the upper bunk. If the bunk bed will be placed next to the wall, the guardrail that runs the full length of the bed should be placed against the wall to prevent entrapment between the bed and wall.
- The use of water or sleep flotation mattresses is prohibited.
- **STRANGULATION HAZARD**-Never attach or hang items to any part of the bunk bed that are not designed for use with the bed; for example, but not limited to, hooks, belts and jump ropes.
- Keep these instructions for future reference.



Safety and Care Advice

Avant de commencer l'assemblage

- Si vous avez besoin d'aide, appelez notre numéro de service 866-969-2603.
- Travaillez dans un endroit spacieux et près du lieu où l'unité sera utilisée, préférablement sur un tapis, ou sur un morceau de l'emballage, afin de protéger le plancher et le produit.
- **Nombre de personnes recommandées pour l'assemblage : 2** (cependant il est toujours préférable d'être assisté par une personne supplémentaire).
- **Temps d'assemblage estimé : 3 heures.**
- Assurez-vous d'avoir bien reçu toutes les pièces. La plupart de celles-ci sont étiquetées ou estampées sur leur côté non fini.
- Lire attentivement chaque étape avant de débiter. Il est très important que chaque étape de montage soit exécutée dans le bon ordre, sinon vous risquez d'éprouver de la difficulté à assembler votre meuble.

Précautions

- Ce produit est conçu pour un usage domestique et n'est pas destiné à des fins commerciales.
- **AVERTISSEMENT CONCERNANT LES JEUNES ENFANTS:** Ce produit contient des petits composants. S'il vous plaît assurez-vous qu'ils soient gardés loin d'eux.
- Certaines pièces ont été pré-assemblées. Elles sont illustrées sur cette page et elles sont disponibles pour un remplacement.
- Périodiquement, vérifiez et assurez-vous que les barres de sécurité, l'échelle et autres composantes sont à la bonne place, qu'ils ne sont pas endommagés et que tous les boulons et écrous sont bien serrés.

Conseils utiles

- Déplacez votre nouveau mobilier avec soin, nous recommandons soulever et transporter le mobilier vers son nouvel emplacement à deux.
- Votre mobilier peut être démonté et ré-assemblé pour faciliter les déménagements.
- Assemblez toutes les pièces et les boulons desserrés pendant l'assemblage, seulement une fois le produit terminé, si vous serrez complètement les boulons.
- Vérifiez régulièrement et assurez-vous que tous les boulons et raccords sont bien serrés.



Safety and Care Advice

Avertissements

- Suivre les informations indiquées sur les avertissements paraissant au bout de la structure du lit superposé et sur la boîte. Ne pas enlever l'étiquette d'avertissement du lit.
- Utilisez toujours la dimension recommandée de matelas, ou de support de matelas, ou les deux pour aider à prévenir les risques possibles de coinçage ou de chute.
- Pour le lit du haut, utilisez uniquement un matelas de **74"-75"** de long par **37½" - 38½"** de large.
- Assurez-vous que l'épaisseur du matelas du lit du haut soit supérieure à **4"**, et qu'elle n'excède pas les **6"**.
- La surface du matelas doit être au moins **5" (127mm)** sous le bord supérieur du garde-corps.
- Ne permettez pas des enfants de moins de 6 ans d'utiliser le lit du haut.
- Ne jouez pas sur ou sous le lit et ne sautez pas sur le lit.
- Interdire l'accès à plus d'une personne sur le lit du haut.
- Utilisez toujours l'échelle pour monter ou descendre du lit du haut.
- Ne substituez pas de pièces. Communiquez avec ACE pour obtenir des pièces de rechange.
- L'usage d'une lumière de nuit peut fournir une précaution supplémentaire lorsqu'un enfant utilise le lit du haut.
- Utilisez toujours les garde-corps sur les deux côtés du lit supérieur. Lorsque le lit superposé est placé le long d'un mur, le garde-corp du lit doit être contre le mur, afin de prévenir qu'un enfant se coince entre le mur et le lit.
- L'utilisation de matelas d'eau ou de matelas gonflable est strictement interdite.
- Ne pas utiliser de rehausseur de lit sous ce produit.
- **Risque d'étranglement** - jamais installer ou accrocher à toute partie du lit des re-align this paragraph articles qui ne sont pas conçus pour une utilisation avec celui-ci; par exemple, mais sans s'y limiter, des crochets, ceintures et cordes à sauter.
- Conservez ces instructions pour référence ultérieure.



Safety and Care Advice

Lea antes de comenzar a ensamblar

- Llame a nuestro número 866-969-2603 si necesita asistencia.
- Trabaje en un área espaciosa y cerca de donde su producto será utilizado, preferiblemente sobre una alfombra o utilice el cartón del empaque para proteger su piso y su producto.
- **El número de personas recomendadas para el montaje de este producto es: 2** (sin embargo es recomendable contar con ayuda adicional).
- **Tiempo estimado de ensamble es: 3 Horas.**
- Asegúrese de que todas las partes están incluidas. La mayoría de las partes están etiquetadas o selladas en los bordes.
- Lea cada paso cuidadosamente. Es muy importante que cada paso de las instrucciones sea realizado en el orden correcto. Si estos pasos no se siguen en secuencia, pueden ocurrir dificultades durante el ensamblado.

Precauciones

- Este producto está diseñado para uso doméstico y no para uso comercial.
- **ADVERTENCIA PARA NIÑOS PEQUEÑOS** - Este producto contiene componentes pequeños. Por favor asegúrese de que las piezas estén fuera del alcance de los niños.
- Algunas partes han sido pre-ensambladas en este producto. Se encuentran ilustradas en esta página y disponibles para reemplazo.
- Compruebe y asegúrese periódicamente de que la barandilla, la escalera y otros componentes están en su posición apropiada, libre de daños, y que todos los conectores están apretados.

Consejos útiles

- Mueva sus muebles nuevos con cuidado, se requiere de dos personas para levantar y trasladar su producto a su nueva ubicación.
- Sus muebles se pueden desmontar y volver a ensamblar en caso de mudanza.
- Ensamble todas las piezas y pernos sueltos durante el ensamblaje, solo una vez que el producto esté completo, debe apretar completamente los pernos.
- Verifique y asegúrese regularmente de que todos los pernos y accesorios estén apretados correctamente.



Safety and Care Advice

Precauciones

- Siga la información sobre las advertencias que aparecen en el extremo superior de la litera y en el empaque. No quite la etiqueta de advertencia de la cama.
- Utilice siempre el colchón del tamaño recomendado, el soporte del colchón recomendado, o ambos, para ayudar a prevenir la probabilidad de quedar atrapado o de caídas.
- Utilice solamente un colchón individual que sea **74"-75"** de largo y **37½" - 38½"** de ancho en la cama superior y cama inferior.
- Asegúrese de que el grosor del colchón en la cama superior sea mayor a **4"** y que no exceda **6"**.
- La superficie del colchón debe estar por lo menos a **5"(127mm)** por debajo del borde superior de las barandillas.
- No permita que los niños menores de 6 años de edad utilicen la cama superior.
- No permita jugar en o debajo de la cama y prohíba saltar en la cama.
- Prohíba a más de una persona en la cama superior.
- Utilice siempre la escalera para subir y bajar de la cama superior.
- No utilice piezas sustitutas. Entre en contacto con ACE para las piezas de reemplazo.
- El uso de una lámpara de noche puede proporcionar más seguridad para un niño que utilice la cama superior.
- Utilice siempre las barandillas en ambos lados largos de la cama superior. Si la litera es colocada contra la pared, la barandilla lateral debe ser colocada de igual forma contra la pared para prevenir quedar atrapado entre la cama y la pared.
- Se prohíbe el uso de colchones de agua.
- No utilice elevadores para cama con este producto.
- **Peligro de estrangulación:** nunca ate o cuelgue artículos de ninguna parte de la litera que no hayan sido diseñados para utilizar con esta; por ejemplo pero sin limitarse a, ganchos, correas y cuerdas de saltar.
- Guarde estas instrucciones para futura referencia.

Components - Panels

Please check you have all the panels listed below

PARTS

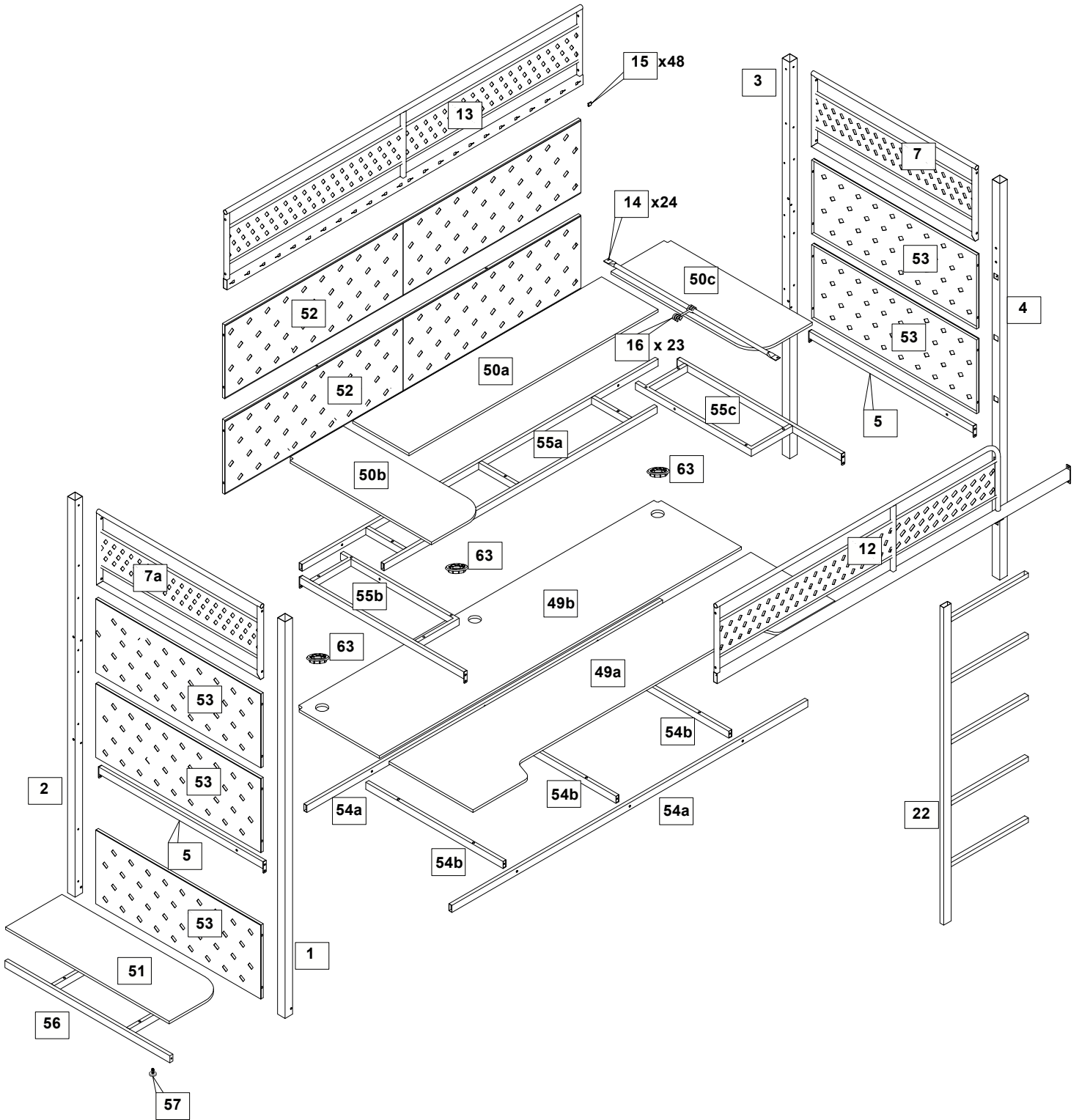

Components - Panels

Please check you have all the panels listed below

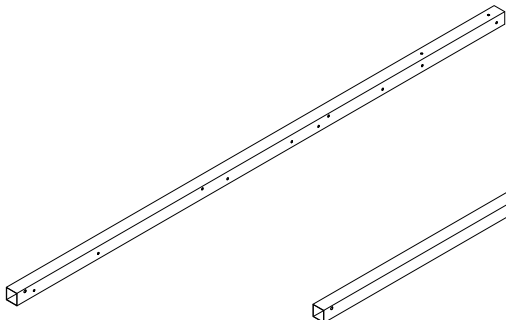

1 Post 01 x 1

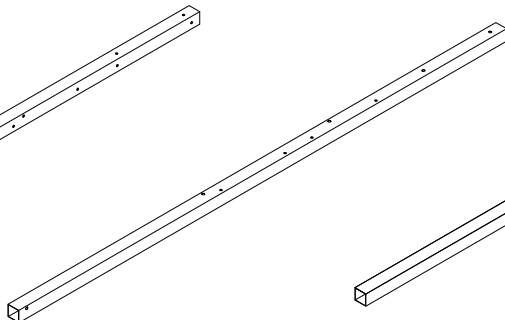

2 Post 02 x 1

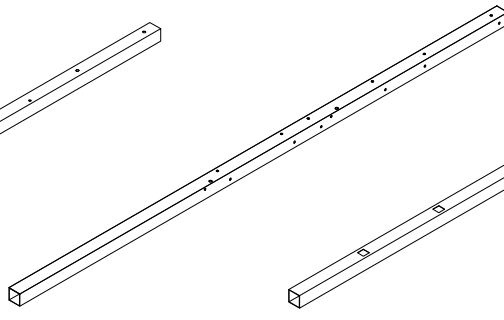

3 Post 03 x 1

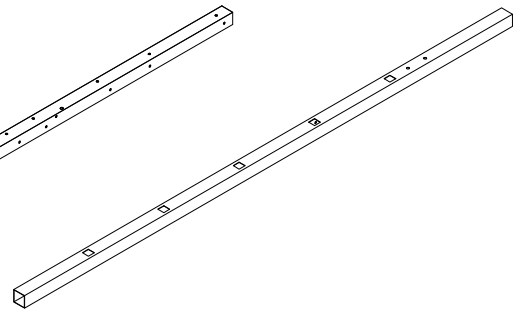

4 Post 04 x 1

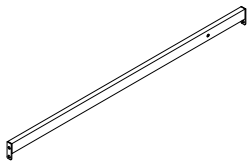

5 Side Rail x 2

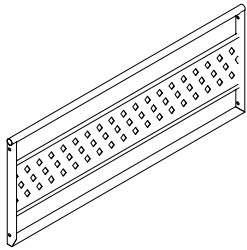

7 Right Guard Rail x 1

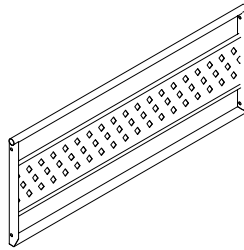

7a Left Guard Rail x 1

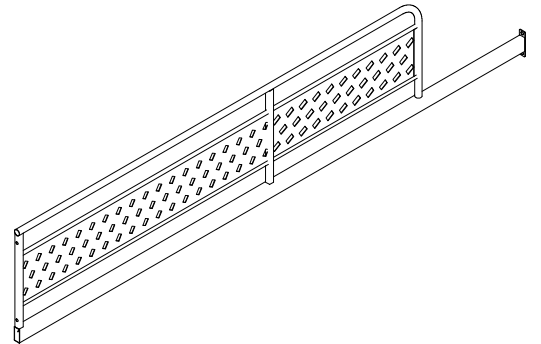

12 Front Guard Rail x 1

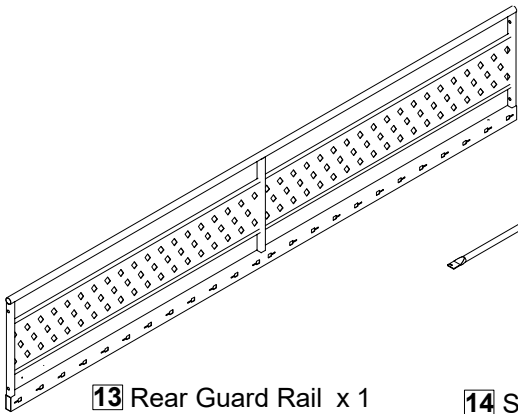

13 Rear Guard Rail x 1

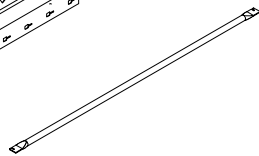

14 Slats x 24



15 Plastic Plug x 48

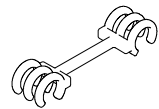

16 Slat Spacer x 23

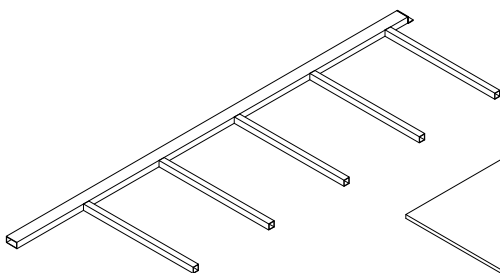

22 Ladder x 1

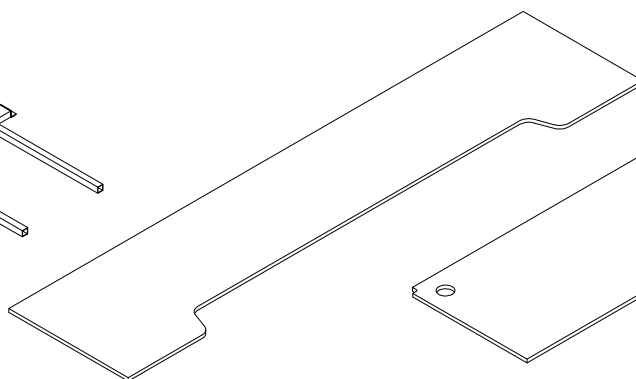

49a Front Desktop x 1

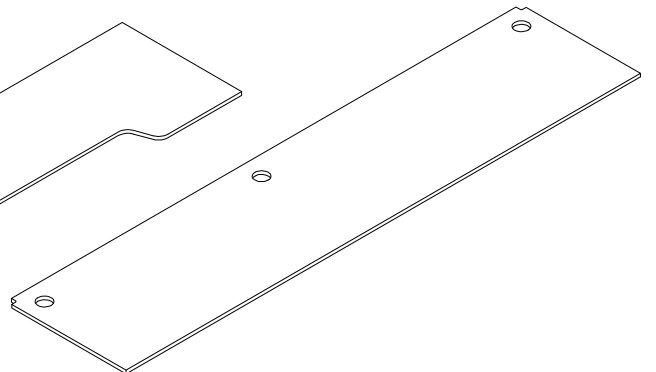

49b Rear Desktop x 1

Components - Panels

Please check you have all the panels listed below

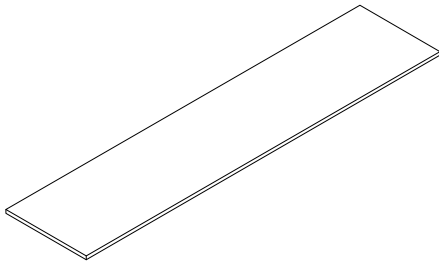

50a Main Shelf x 1

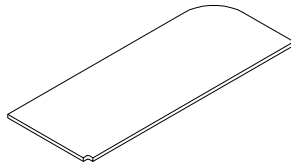

50b Left Shelf x 1

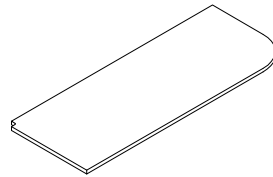

50c Right Shelf x 1

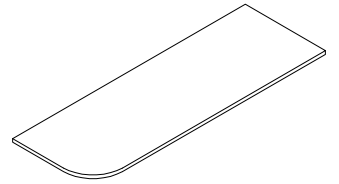

51 Bottom Shelf x 1

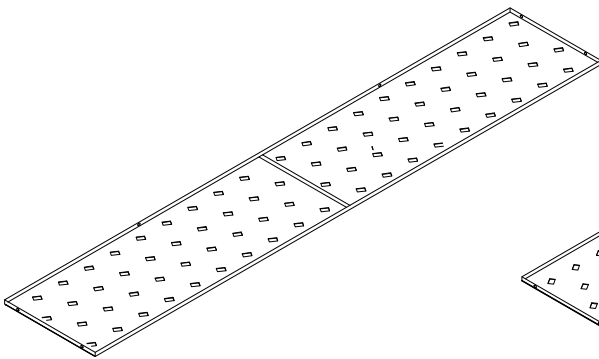

52 Rear Mesh Panel x 2

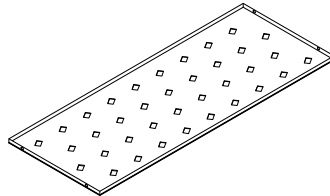

53 Side Mesh Panel x 5

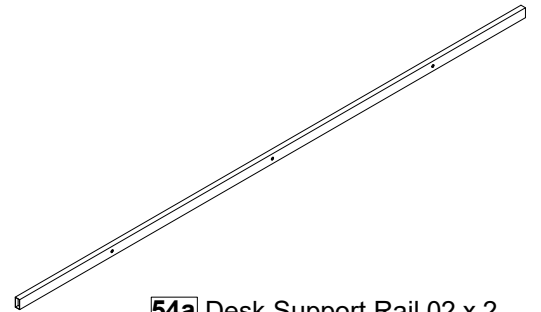

54a Desk Support Rail 02 x 2

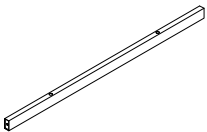

54b Desk Support Rail 01 x 3

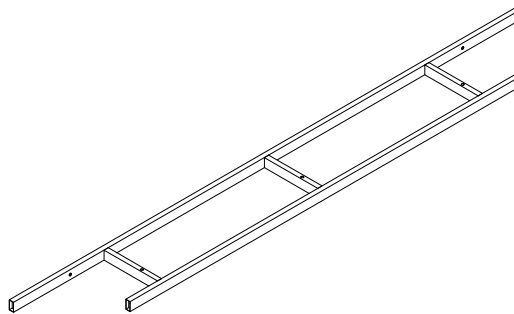

55a Main Shelf Support x 1

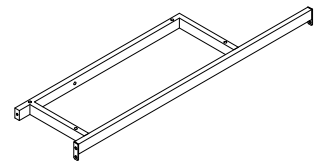

55b Left Shelf Support Frame x 1

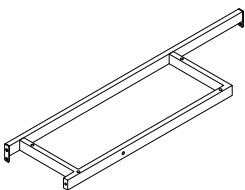

55c Right Shelf Support Frame x 1

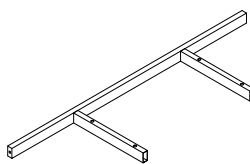

56 Lower Shelf Support x 1



57 Pad x 2









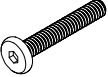
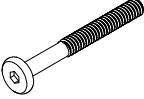

63 Cable Cap x 3

Components - Fittings

Please check you have all the panels listed below

Note: The quantities below are the correct amount to complete the assembly. In some cases more fittings may be supplied as required.

| | | |
|--|---|---|
| <p>N</p>  <p>17mm Bolt M6 x 39</p> | <p>B</p>  <p>25mm Bolt M6 x 7</p> | <p>C</p>  <p>30mm Bolt M6 x14</p> |
| <p>D</p>  <p>38mm Bolt M6x33</p> | <p>E</p>  <p>60mm Bolt M6 x 6</p> | <p>H</p>  <p>M6 x 2</p> |
| <p>I</p>  <p>M6 Spring washer x 8</p> | <p>J</p>  <p>M6 Metal washer x 8</p> | <p>K</p>  <p>M6 Plastic washer x 8</p> |
| <p>L</p>  <p>Allen Key x 1</p> | <p>M</p>  <p>Wrench x 1</p> | |

Tools required



Ruler/tape
measure

Ruler - User this ruler to help correctly identify the screws



Assembly Instructions

Step 1

Attach Left Guard Rail **7a** to Post 01 **1** and Post 02 **2** with **C**.

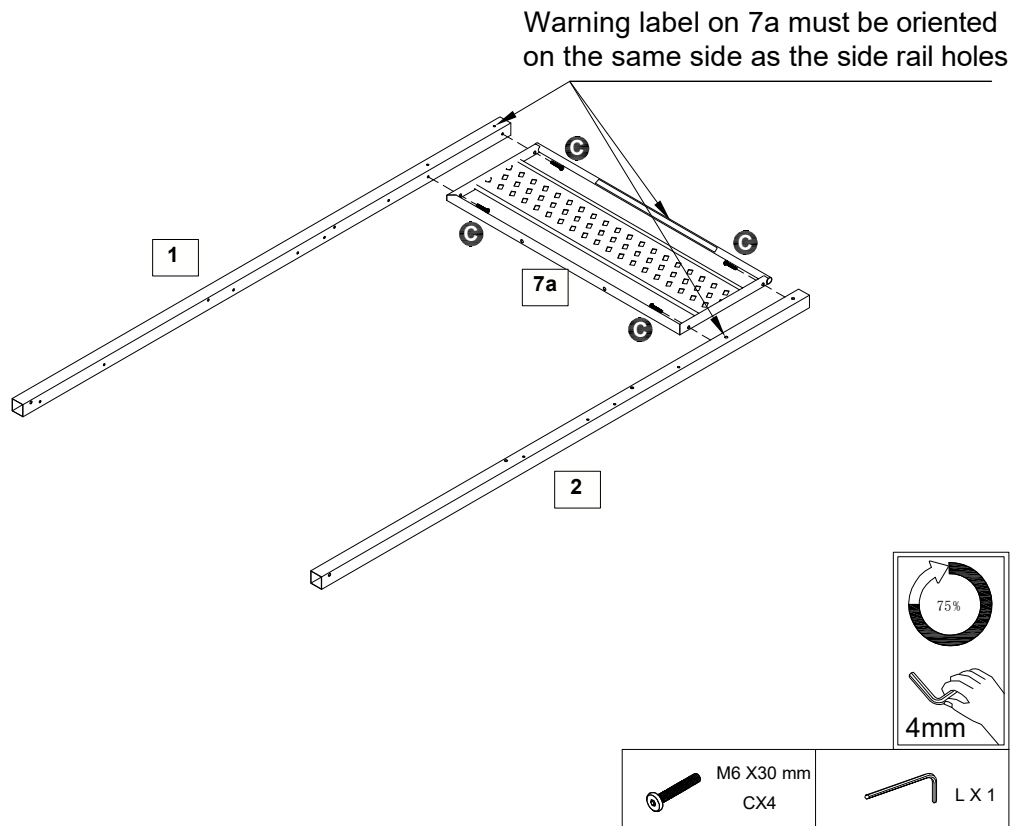

Step 2

Attach Right Guard Rail **7** to Post 03 **3** and Post 04 **4** with **C**.

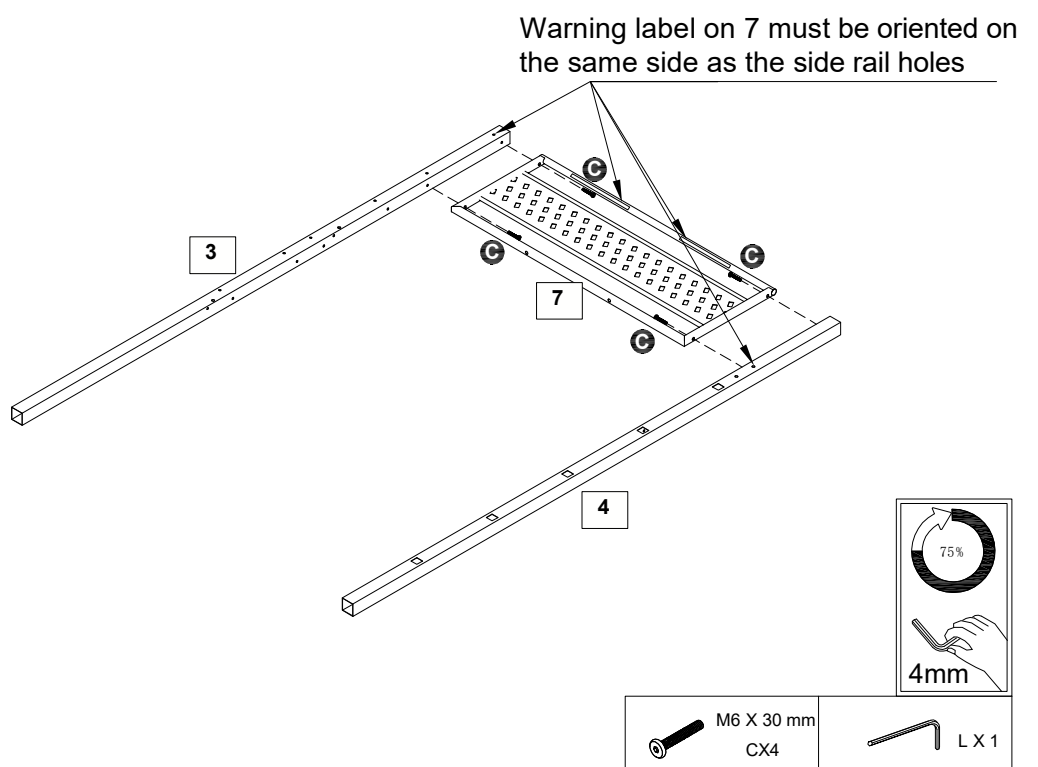

Assembly Instructions

Step 3

Attach Rear Guard Rail **13** to Post 02 **2** and Post 03 **3** with **C**, **I**, **J**, **K**.

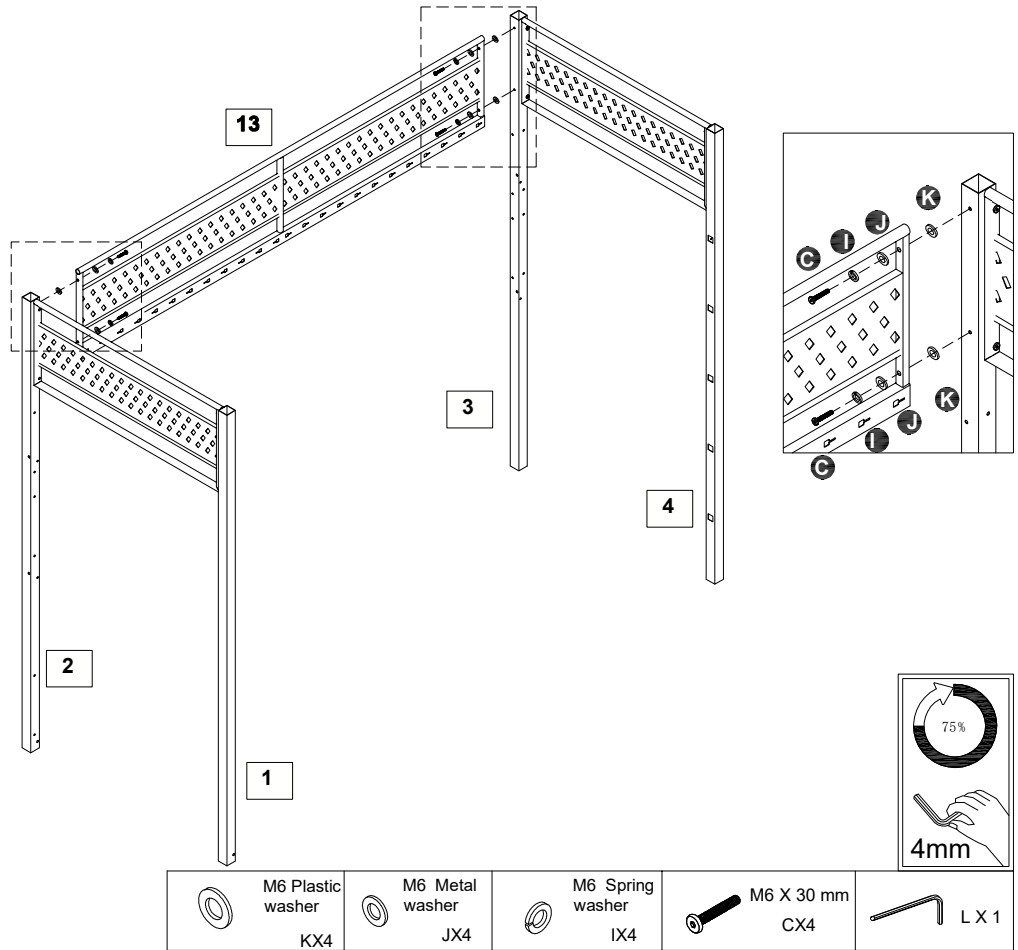

Step 4

Insert Ladder **22** into Post 04 **4** with **B**.

You may need to adjust the tread manually to insert to the holes one by one on Post 04 **4**.

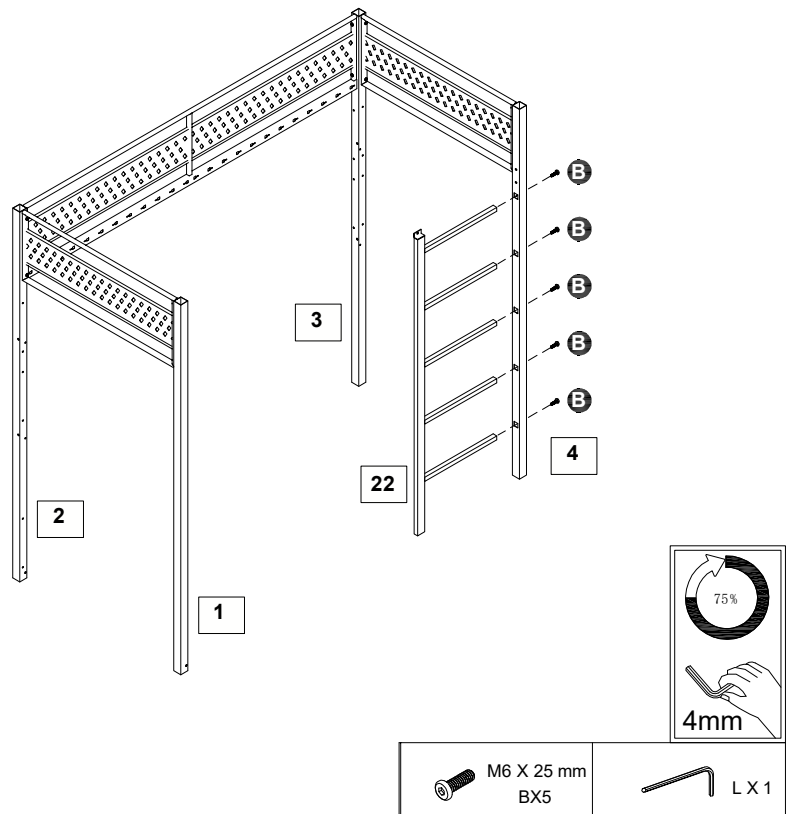







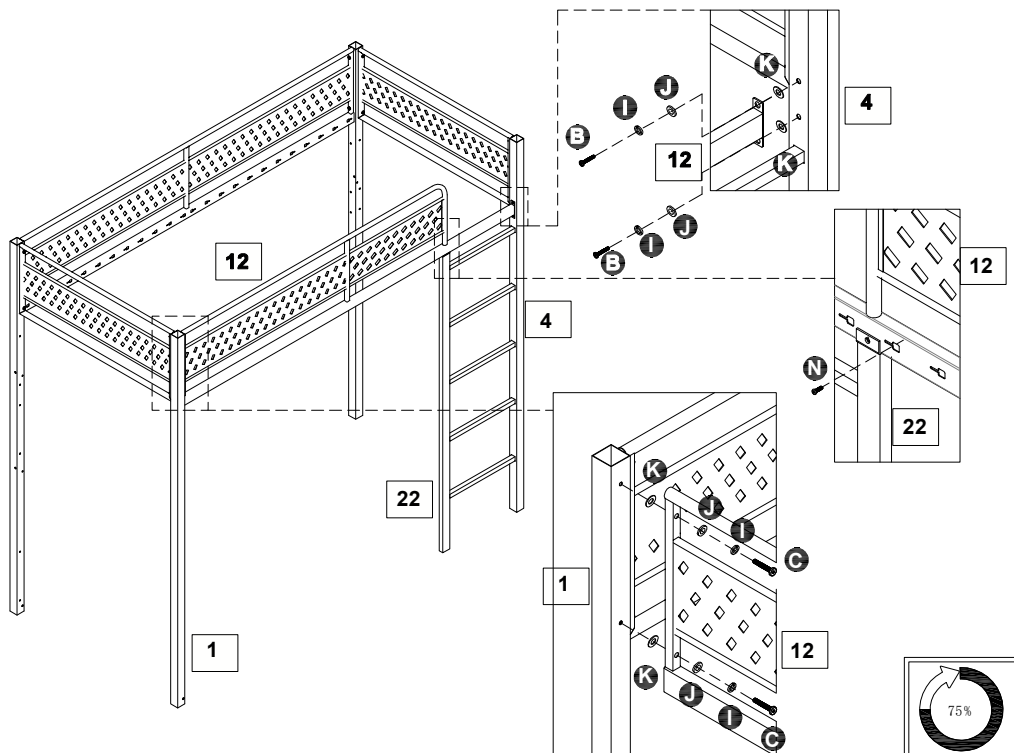

Assembly Instructions

Step 5

a: Attach Front Guard Rail **12** to Post 01 **1** with **C**, **I**, **J**, **K**, and Post 04 with **B**, **I**, **J**, **K**

b: Attach Ladder **22** to Front Guard Rail **12** with **N**.





| | | | | | |
|---|---|---|--|---|---|
|  M6 Plastic washer KX4 |  M6 Spring washer IX4 |  M6 X 30 mm CX2 |  M6 X 25 mm BX2 |  M6 X 17 mm NX1 |  4mm |
|  M6 Metal washer JX4 | | | | |  L X 1 |

Step 6

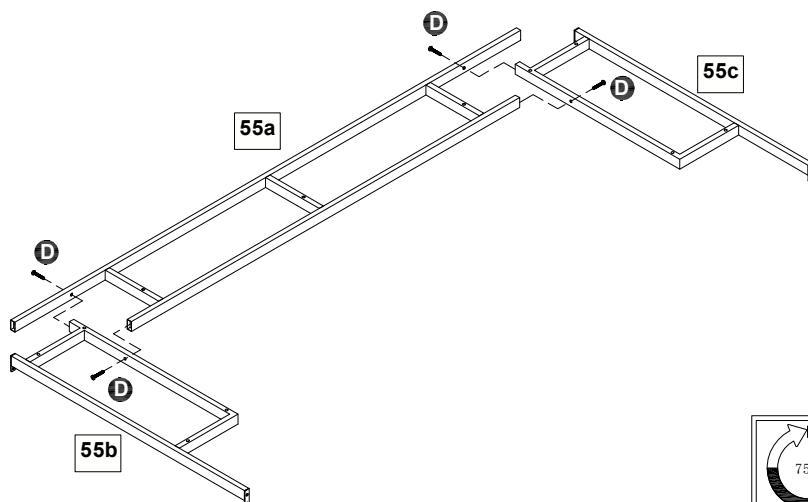
Attach Left Shelf Support Frame **55b** and Right Shelf Support Frame **55c** to Main Shelf Support **55a** with **D**.



| | |
|---|---|
|  M6 X 38 mm DX4 |  L X 1 |
|---|---|

Assembly Instructions

Step 7

a: Attach Left Shelf Support Frame **55b** to Post 01 **1** and Post 02 **2** with **N**.

b: Attach Right Shelf Support Frame **55c** to Post 03 **3** and Post 04 **4** with **N**.

c: Attach Main Shelf Support **55a** to Post 02 **2** and Post 03 **3** with **E**.

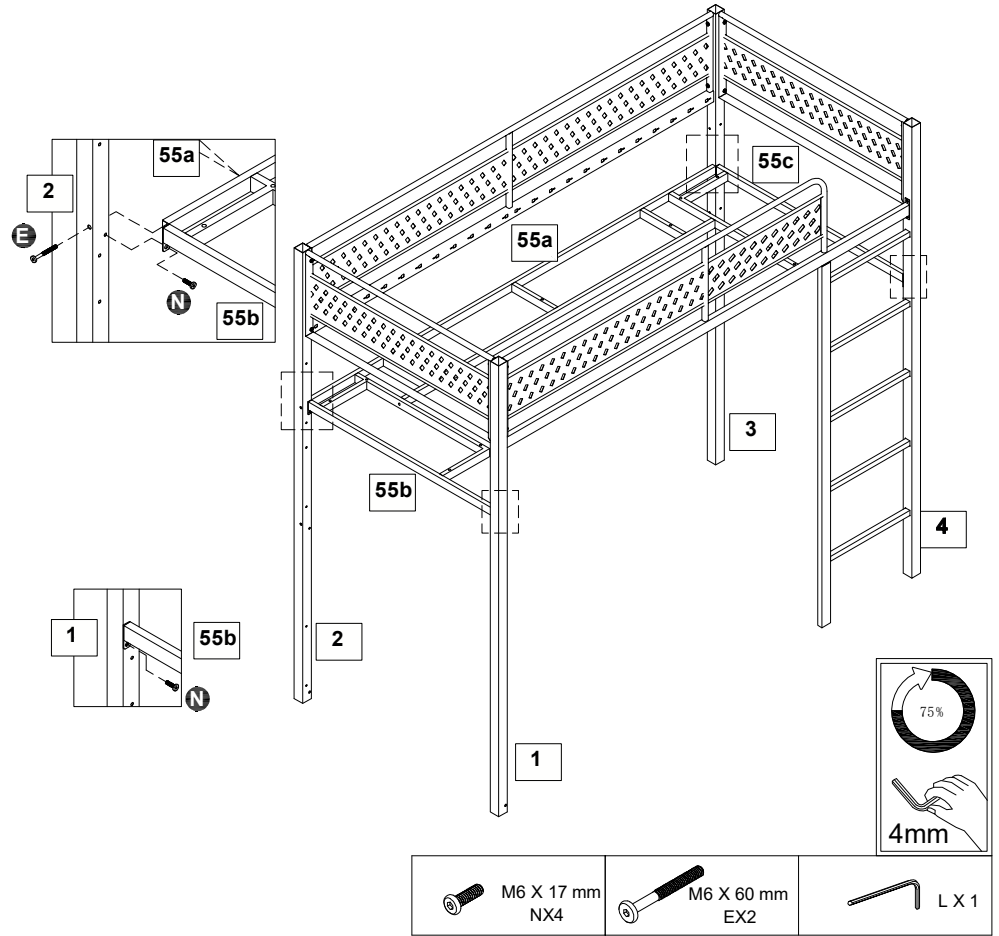

Step 8

a: Attach Side Rail **5** to Post 01 **1** and Post 02 **2** with **N**.

b: Attach Side Rail **5** to Post 03 **3** and Post 04 **4** with **N**.

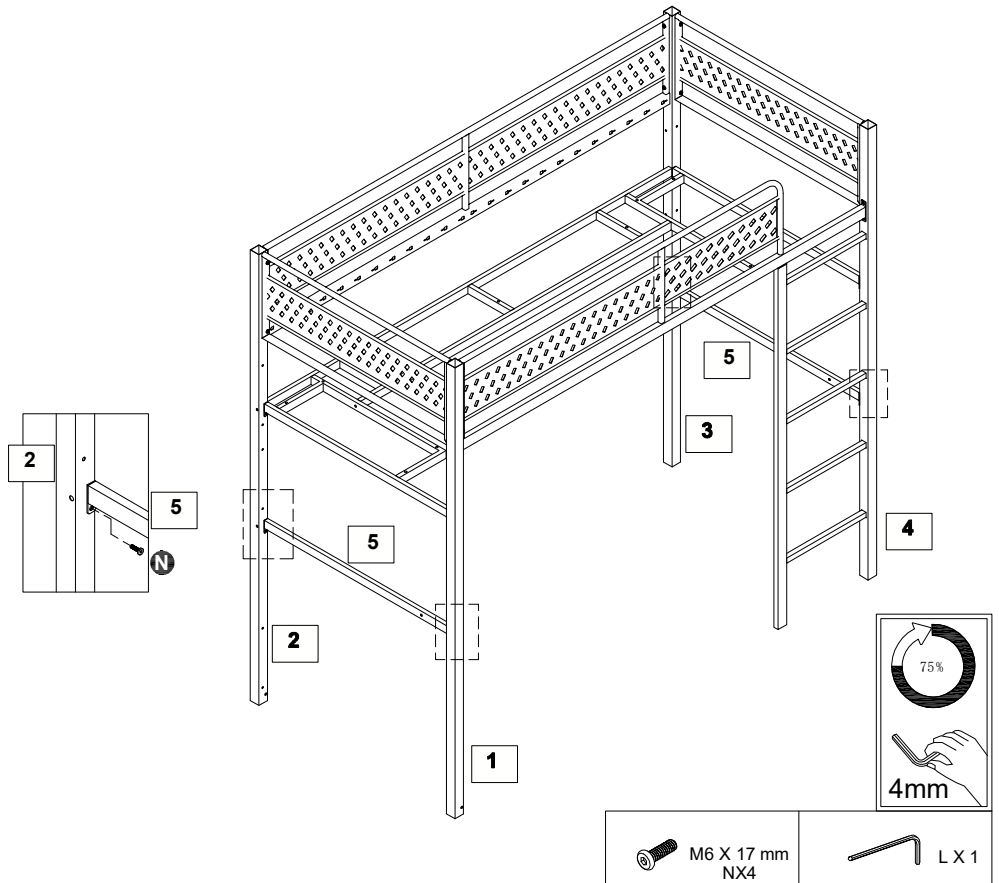

Assembly Instructions

Step 9

Attach Desk Support Rail
01 **54b** x3 to Desk Support Rail
02 **54a** x2 with **D**.

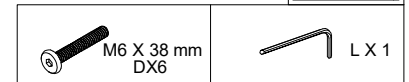
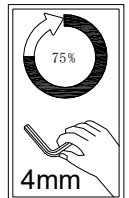
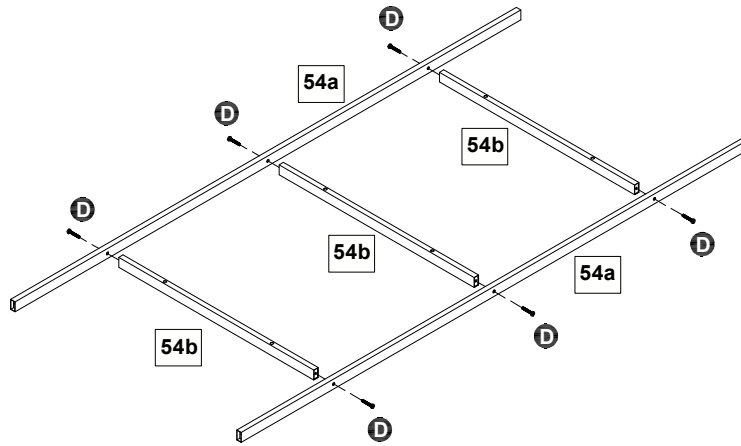

Step 10

a: Attach Desk Support Rail
02 **54a** to Side Rail **5** with **D**.

b: Attach Desk Support Rail
02 **54a** to Post 02 **2** and
Post 03 **3** with **E**.

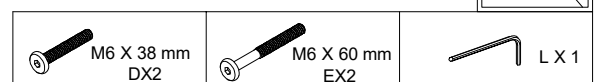
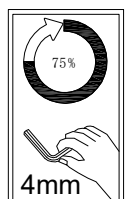
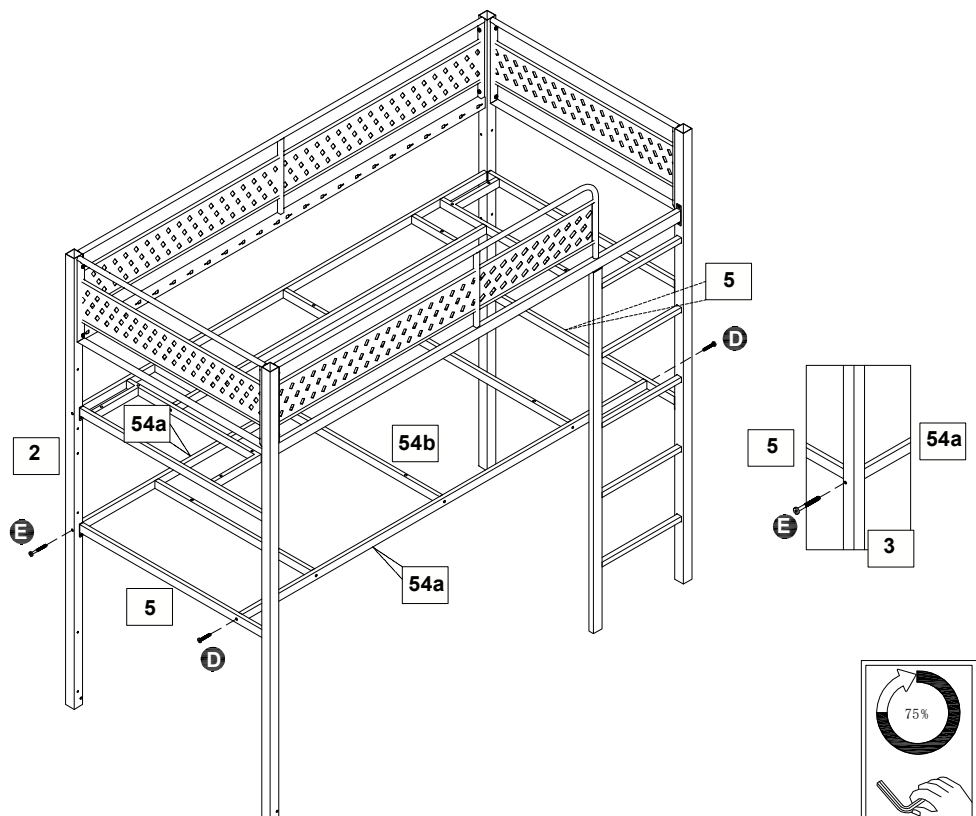

Assembly Instructions

Step 11

a: Attach Lower Shelf Support **56** to Bottom Shelf **51** with **D**.

b: Attach Pad **57** x2 to Lower Shelf Support **56**.

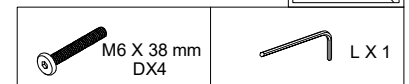
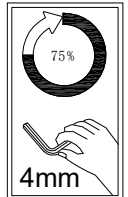
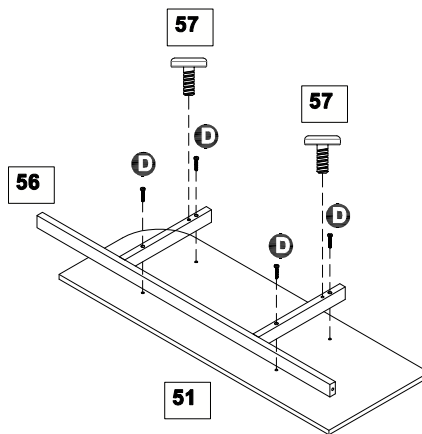

Step 12

Attach Lower Shelf Support **56** to Post 01 **1** and Post 02 **2** with **E**.

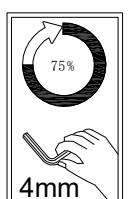
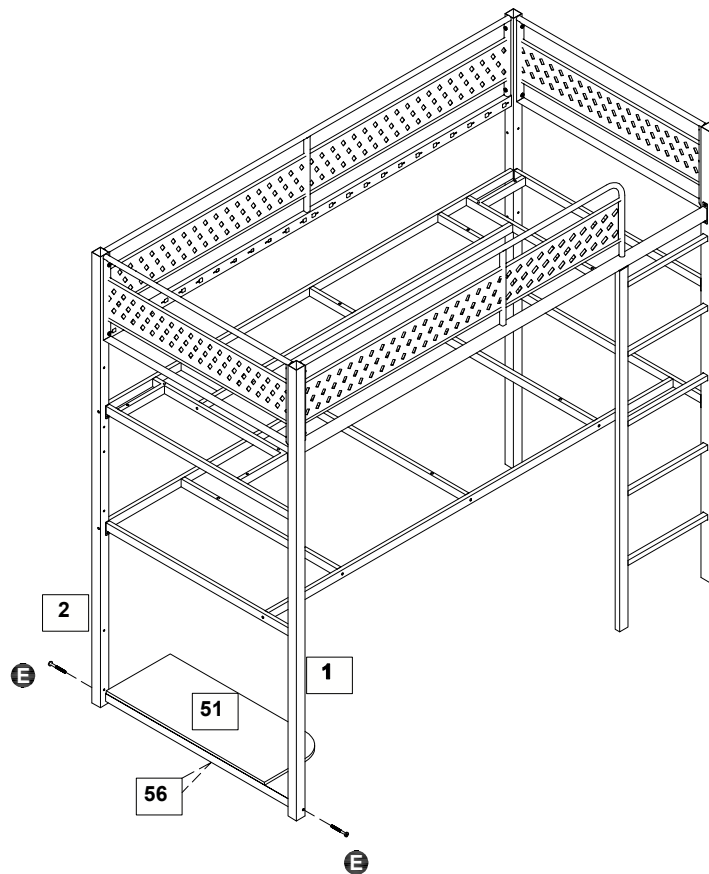

Assembly Instructions

Step 13

a: Attach Left Shelf **50b** to Left Shelf Support Frame **55b** with **D**.

b: Attach Right Shelf **50c** to Right Shelf Support Frame **55c** with **D**.

c: Attach Main Shelf **50a** to Main Shelf Support **55a** with **D**.

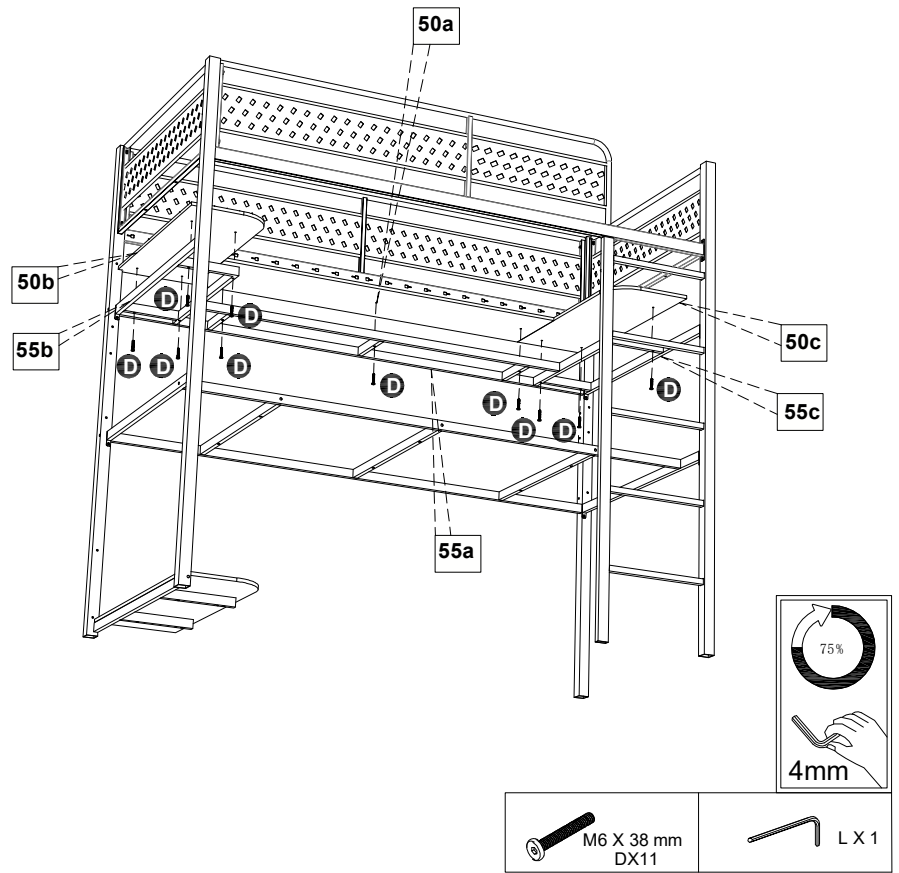

Step 14

Attach Cable Cap **63** x3 to Rear Desktop **49b**.

The cover could be removed before passing through the cable assembled back when finished.

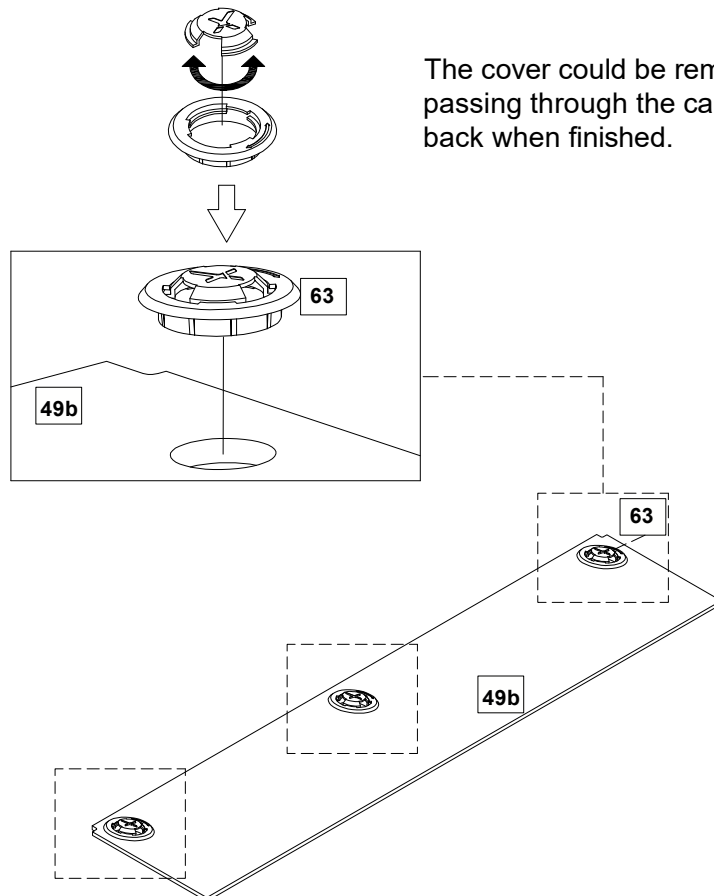

Assembly Instructions

Step 15

Attach Rear Desktop **49b** to Desk Support Rail 01 **54b** with **D**.

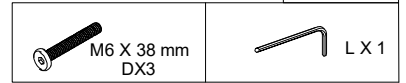
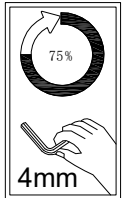
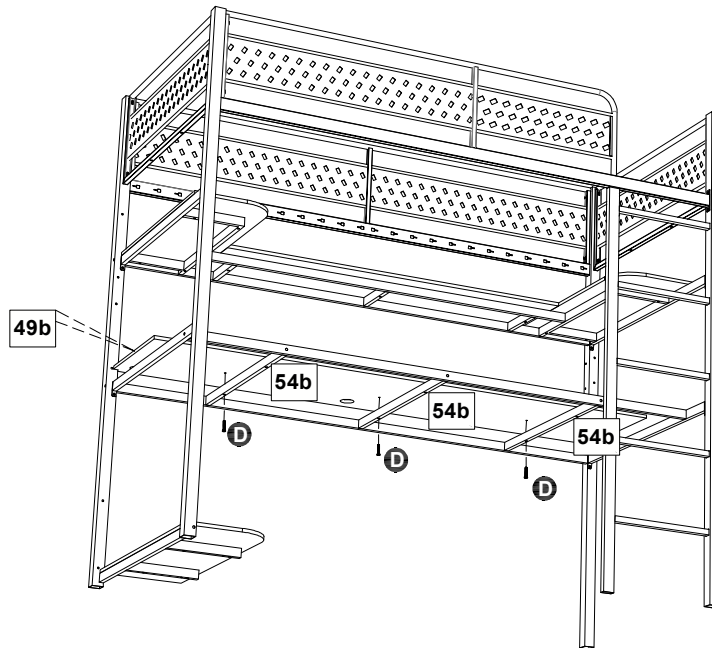

Step 16

Attach Front Desktop **49a** to Desk Support Rail 01 **54b** with **D**.

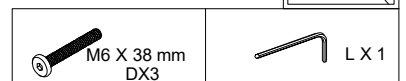
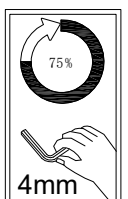
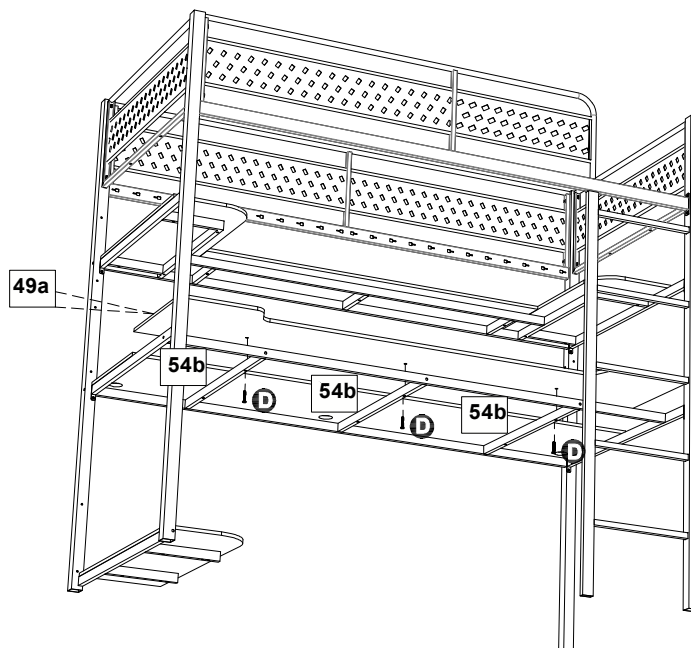

Assembly Instructions

Step 17

Attach Side Mesh Panel **53** x2 to Post **03** **3** and Post **04** **4** with **N**.

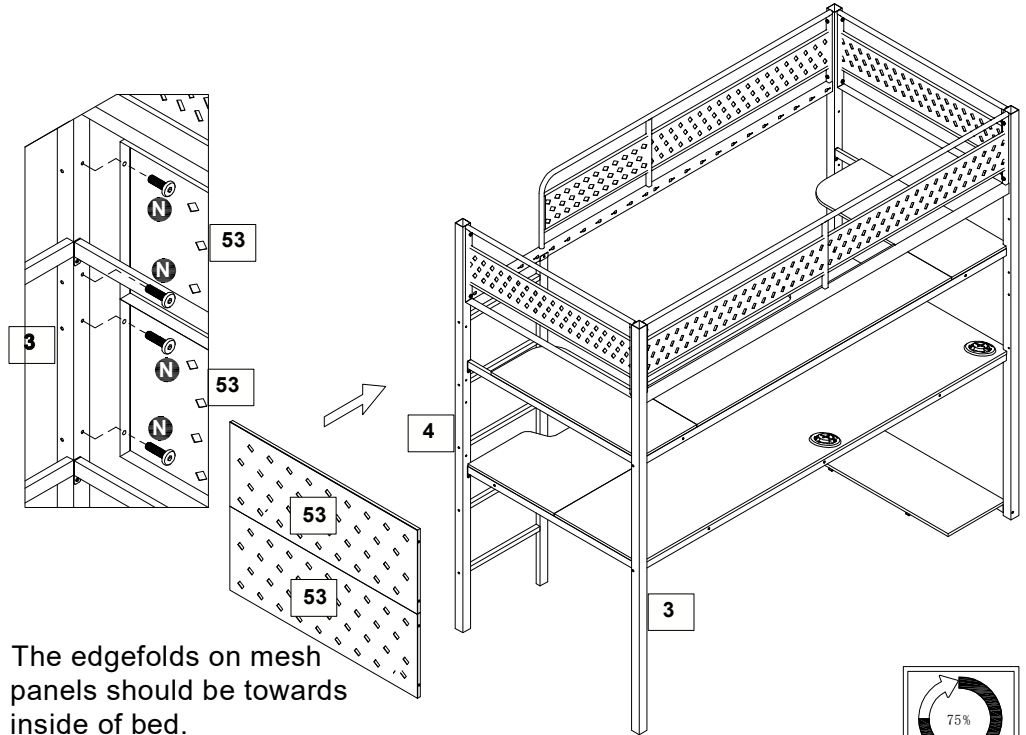

The edgefolds on mesh panels should be towards inside of bed.

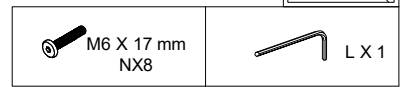
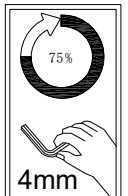
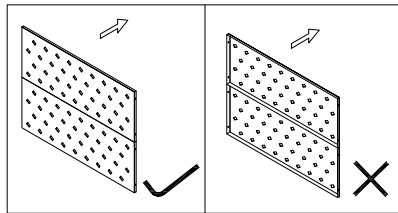

Step 18

Attach Side Mesh Panel **53** x3 to Post **01** **1** and Post **02** **2** with **N**.

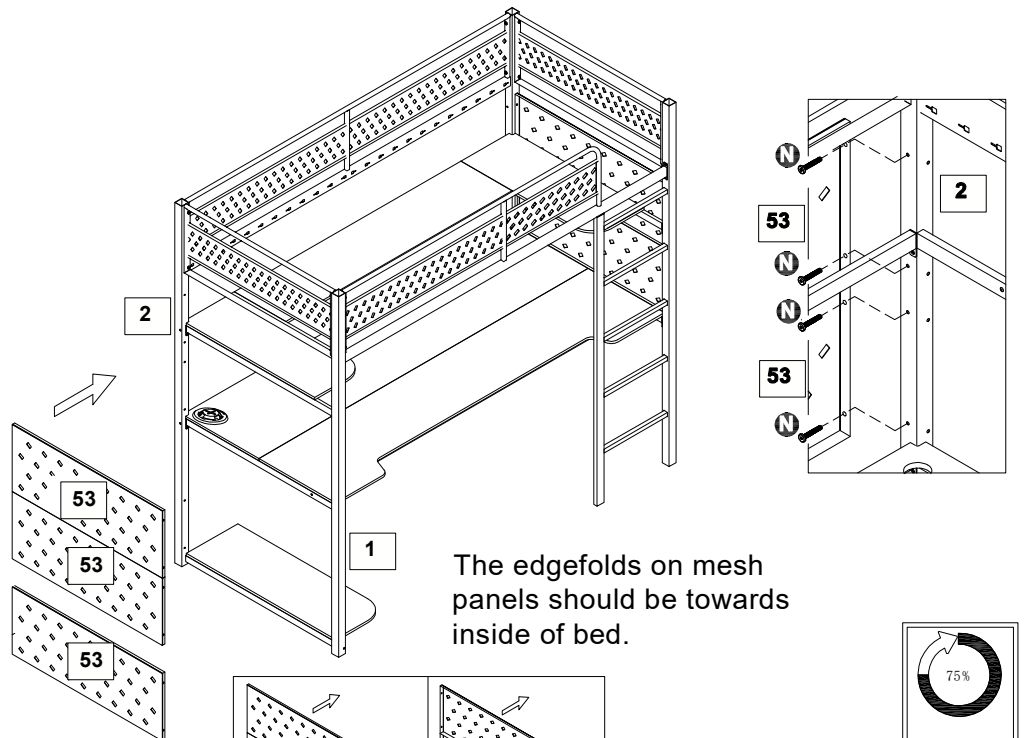

The edgefolds on mesh panels should be towards inside of bed.

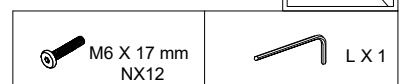
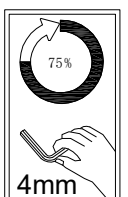
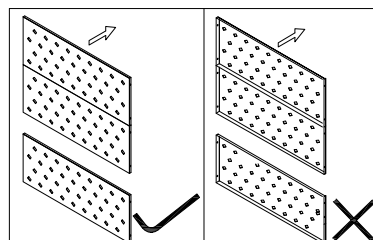

Assembly Instructions

Step 19



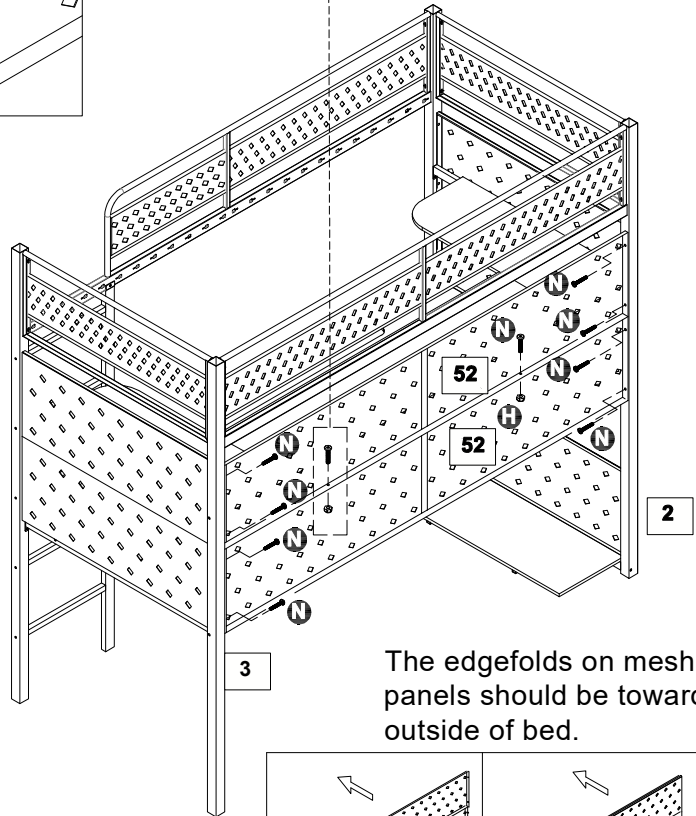
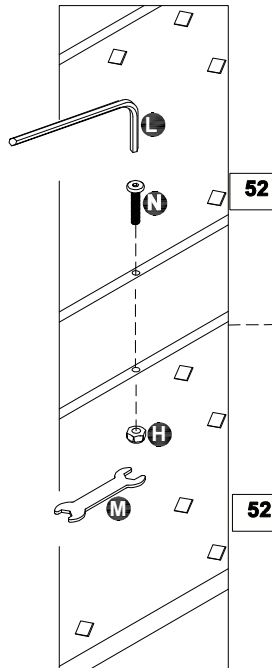

a: Attach Rear Mesh Panel
 52 x2 to Post 02 2 and Post
 03 3 with N .

b: Attach Rear Mesh Panel
 52 x2 together with N H .

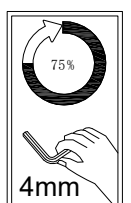
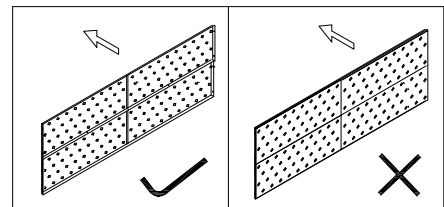

The edgefolds on mesh panels should be towards outside of bed.



| | | | |
|--|---|---|--|
|  M6 X 17 mm NX10 |  M6 HX2 |  L X 1 |  MX 1 |
|--|---|---|--|

Assembly Instructions

Step 20

a: Secure the Slats **14a** x24 to Rear Guard Rail **13** and Front Guard Rail **12** .

b: Secure the Plastic Plug **15** x48 to Rear Guard Rail **13** and Front Guard Rail **12** .

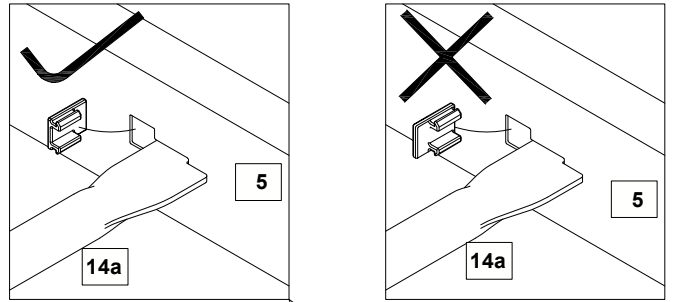

a:

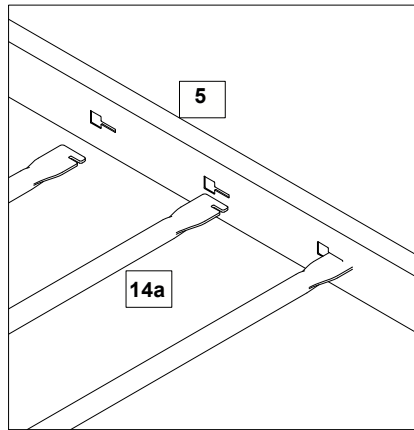

b:

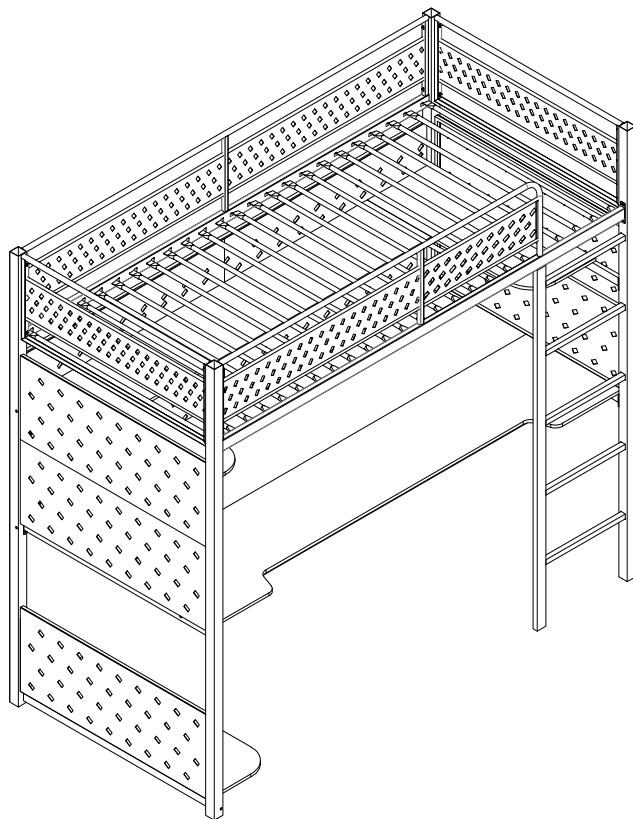
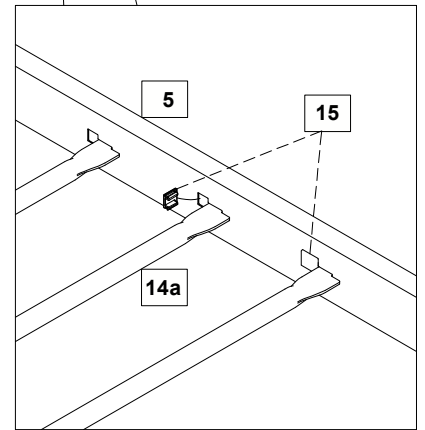

Assembly Instructions

Step 21

Secure slat spacer **16**x23 to slats **14**x24.

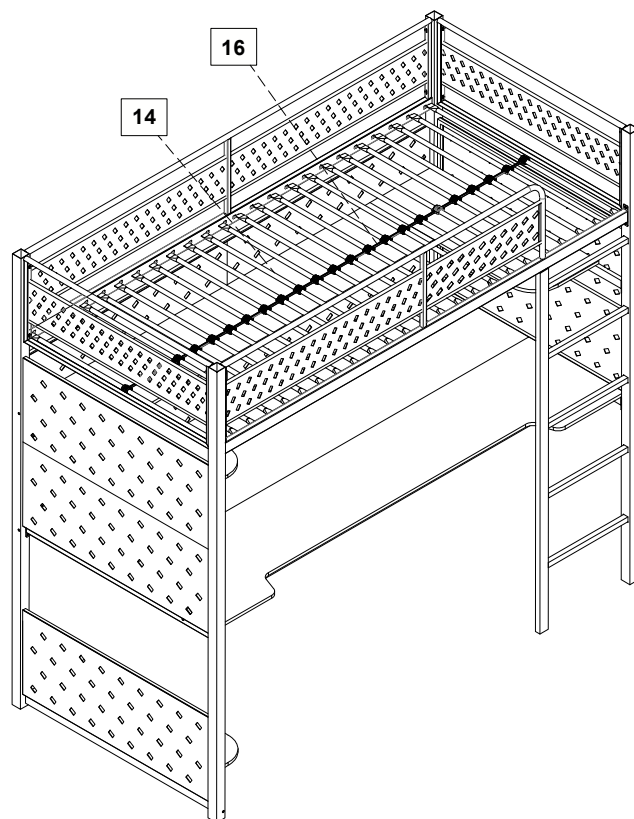
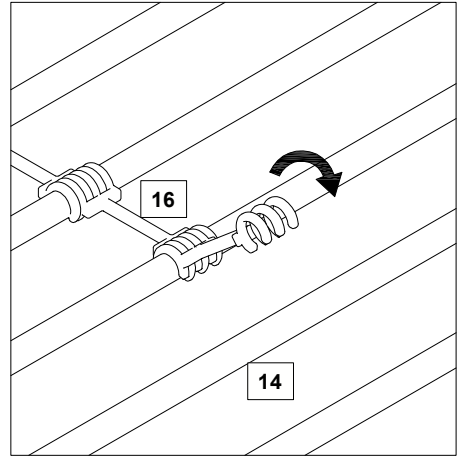

Assembly Instructions

Step 22

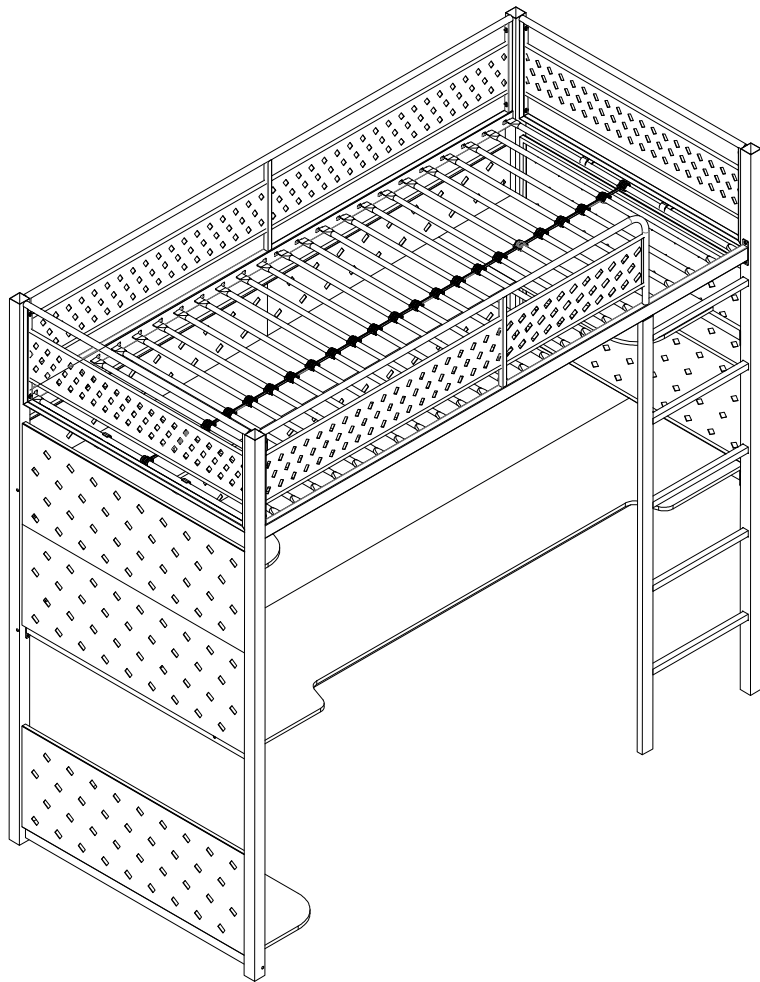

Assembly is complete

