

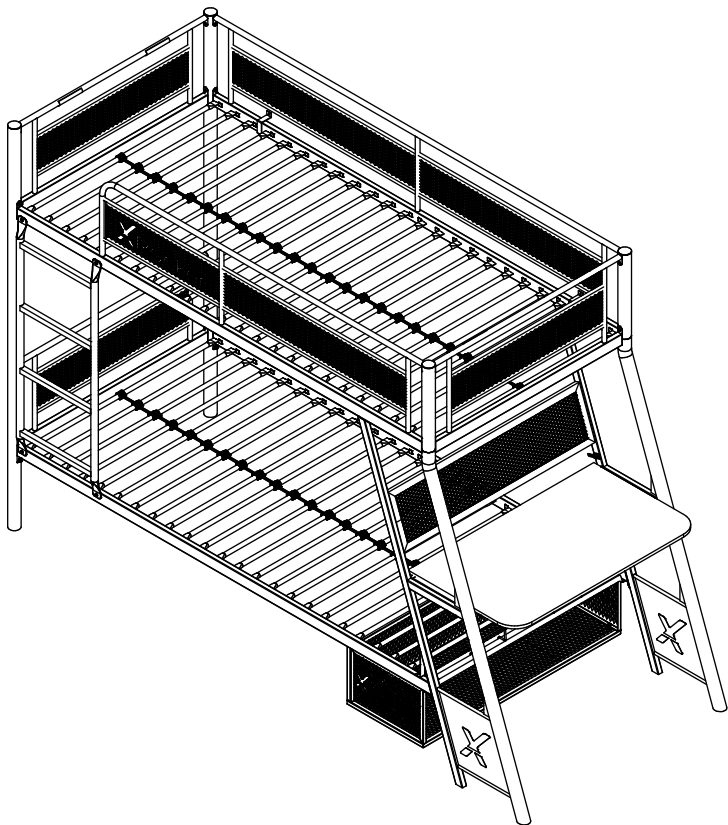

# ARMADA DUAL BUNK BED WITH BUILT-IN DESK



NEED SUPPORT?



[xrockergaming.com/pages/support](http://xrockergaming.com/pages/support)

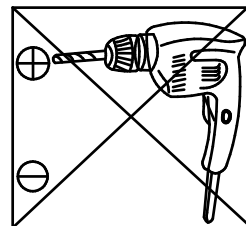

SIZE: 95.6 X 41.5 X 64.2

PLEASE READ this sheet prior to assembly to familiarize yourself with the various stages of construction.

Carefully open the pack supplied and check the contents against the parts and fittings check list. Do not destroy any of the packaging until you are certain that you have all the necessary parts for the assembly.

CAUTION: There are small components used in the construction of this unit. These items should be kept away from young children whilst assembling your unit to avoid danger of choking.

## TOOLS REQUIRED



2 PEOPLE

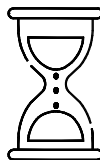

1.5 HOUR SET UP



## Safety and Care Advice

### Read Before Beginning Assembly

- Call 866-969-2603 if you need assistance.
- Work in a spacious area and near where the unit will be used, preferably on a carpet, or use a piece of the cardboard packaging to protect your floor and product.
- Recommended # of people needed for assembly: **2** (however it is always better to have an extra hand).
- Estimated assembly time is **1.5** hours.
- Make sure all parts are included. Most parts are labeled or stamped on the raw edge.
- Read each step carefully. It is very important that each step of the instructions is performed in the correct order. If these steps are not followed in sequence, assembly difficulties will occur.

### Caution

- This product is designed for home use and not intended for commercial use.
- This product contains small components. Please ensure that they are kept away from small children.
- Clean the product with a soft damp cloth . DO NOT use harsh chemicals or abrasive cleaners.
- Periodically check and ensure that the guardrail, ladder, and other components are in their proper position, free from damage, and that all connectors are tight.

### Handy Hints

- Move your new furniture carefully, with two people lifting and carrying the unit to its new location.
- Your furniture can be disassembled and reassembled to move.
- Assemble all parts and bolts loosely during assembly, only once the product is complete should you fully tighten the bolts
- Regularly check and ensure that all bolts and fittings are tightened properly.



# Safety and Care Advice

## WARNINGS

- Follow the information on the warnings appearing on the upper bunk end structure and on the carton. Do not remove warning label from bed.
- Always use the recommended size mattresses or mattress supports, or both, to help prevent the likelihood of entrapment or falls.
- Use only a mattress which is **74" - 75"** long and **37½" - 38½"** wide on upper bunk.
- Ensure thickness of mattress on upper bunk is greater than 4" and that it does not exceed 6".
- Surface of mattress must be at least 5" (127 mm) below the upper edge of guardrails.
- Do not allow children under 6 years of age to use the upper bunk.
- Do not allow horseplay on or under the bed and prohibit jumping on the bed.
- Prohibit more than one person on upper bunk.
- Always use the ladder for entering and leaving the upper bunk.
- Do not use substitute parts. Contact the manufacturer or dealer for replacement parts.
- Use of a night light may provide added safety precaution for a child using the upper bunk.
- Always use guardrails on both long sides of the upper bunk. If the bunk bed will be placed next to the wall, the guardrail that runs the full length of the bed should be placed against the wall to prevent entrapment between the bed and wall.
- The use of water or sleep flotation mattresses is prohibited.
- **STRANGULATION HAZARD**-Never attach or hang items to any part of the bunk bed that are not designed for use with the bed; for example, but not limited to, hooks, belts and jump ropes.
- Keep these instructions for future reference.



## Safety and Care Advice

### Avant de commencer l'assemblage

- Si vous avez besoin d'aide, appelez notre numéro de service 866-969-2603.
- Travaillez dans un endroit spacieux et près du lieu où l'unité sera utilisée, préférablement sur un tapis, ou sur un morceau de l'emballage, afin de protéger le plancher et le produit.
- **Nombre de personnes recommandées pour l'assemblage : 2** (cependant il est toujours préférable d'être assisté par une personne supplémentaire).
- **Temps d'assemblage estimé : 1.5 heures.**
- Assurez-vous d'avoir bien reçu toutes les pièces. La plupart de celles-ci sont étiquetées ou estampées sur leur côté non fini.
- Lire attentivement chaque étape avant de débiter. Il est très important que chaque étape de montage soit exécutée dans le bon ordre, sinon vous risquez d'éprouver de la difficulté à assembler votre meuble.

### Précautions

- Ce produit est conçu pour un usage domestique et n'est pas destiné à des fins commerciales.
- **AVERTISSEMENT CONCERNANT LES JEUNES ENFANTS:** Ce produit contient des petits composants. S'il vous plaît assurez-vous qu'ils soient gardés loin d'eux.
- Certaines pièces ont été pré-assemblées. Elles sont illustrées sur cette page et elles sont disponibles pour un remplacement.
- Périodiquement, vérifiez et assurez-vous que les barres de sécurité, l'échelle et autres composantes sont à la bonne place, qu'ils ne sont pas endommagés et que tous les boulons et écrous sont bien serrés.

### Conseils utiles

- Déplacez votre nouveau mobilier avec soin, nous recommandons soulever et transporter le mobilier vers son nouvel emplacement à deux.
- Votre mobilier peut être démonté et ré-assemblé pour faciliter les déménagements.
- Assemblez toutes les pièces et les boulons desserrés pendant l'assemblage, seulement une fois le produit terminé, si vous serrez complètement les boulons.
- Vérifiez régulièrement et assurez-vous que tous les boulons et raccords sont bien serrés.



# Safety and Care Advice

## ⚠ Avertissements

- Suivre les informations indiquées sur les avertissements paraissant au bout de la structure du lit superposé et sur la boîte. Ne pas enlever l'étiquette d'avertissement du lit.
- Utilisez toujours la dimension recommandée de matelas, ou de support de matelas, ou les deux pour aider à prévenir les risques possibles de coincage ou de chute.
- Pour le lit du haut, utilisez uniquement un matelas de **74" - 75"** de long par **37½" - 38½"** de large.
- Assurez-vous que l'épaisseur du matelas du lit du haut soit supérieure à **4"**, et qu'elle n'excède pas les **6"**.
- La surface du matelas doit être au moins **5" (127mm)** sous le bord supérieur du garde-corps.
- Ne permettez pas des enfants de moins de 6 ans d'utiliser le lit du haut.
- Ne jouez pas sur ou sous le lit et ne sautez pas sur le lit.
- Interdire l'accès à plus d'une personne sur le lit du haut.
- Utilisez toujours l'échelle pour monter ou descendre du lit du haut.
- Ne substituez pas de pièces. Communiquez avec ACE pour obtenir des pièces de rechange.
- L'usage d'une lumière de nuit peut fournir une précaution supplémentaire lorsqu'un enfant utilise le lit du haut.
- Utilisez toujours les garde-corps sur les deux côtés du lit supérieur. Lorsque le lit superposé est placé le long d'un mur, le garde-corps du lit doit être contre le mur, afin de prévenir qu'un enfant se coince entre le mur et le lit.
- L'utilisation de matelas d'eau ou de matelas gonflable est strictement interdite.
- Ne pas utiliser de rehausseur de lit sous ce produit.
- **Risque d'étranglement** - jamais installer ou accrocher à toute partie du lit des re-align this paragraph articles qui ne sont pas conçus pour une utilisation avec celui-ci; par exemple, mais sans s'y limiter, des crochets, ceintures et cordes à sauter.
- Conservez ces instructions pour référence ultérieure.



## Safety and Care Advice

### Lea antes de comenzar a ensamblar

- Llame a nuestro número 866-969-2603 si necesita asistencia.
- Trabaje en un área espaciosa y cerca de donde su producto será utilizado, preferiblemente sobre una alfombra o utilice el cartón del empaque para proteger su piso y su producto.
- **El número de personas recomendadas para el montaje de este producto es: 2** (sin embargo es recomendable contar con ayuda adicional).
- **Tiempo estimado de ensamble es: 1.5 Horas.**
- Asegúrese de que todas las partes están incluidas. La mayoría de las partes están etiquetadas o selladas en los bordes.
- Lea cada paso cuidadosamente. Es muy importante que cada paso de las instrucciones sea realizado en el orden correcto. Si estos pasos no se siguen en secuencia, pueden ocurrir dificultades durante el ensamblado.

### Precauciones

- Este producto está diseñado para uso doméstico y no para uso comercial.
- **ADVERTENCIA PARA NIÑOS PEQUEÑOS** - Este producto contiene componentes pequeños. Por favor asegúrese de que las piezas estén fuera del alcance de los niños.
- Algunas partes han sido pre-ensambladas en este producto. Se encuentran ilustradas en esta página y disponibles para reemplazo.
- Compruebe y asegúrese periódicamente de que la barandilla, la escalera y otros componentes están en su posición apropiada, libre de daños, y que todos los conectores están apretados.

### Consejos útiles

- Mueva sus muebles nuevos con cuidado, se requiere de dos personas para levantar y trasladar su producto a su nueva ubicación.
- Sus muebles se pueden desmontar y volver a ensamblar en caso de mudanza.
- Ensamble todas las piezas y pernos sueltos durante el ensamblaje, solo una vez que el producto esté completo, debe apretar completamente los pernos.
- Verifique y asegúrese regularmente de que todos los pernos y accesorios estén apretados correctamente.



# Safety and Care Advice

## ⚠ Precauciones

- Siga la información sobre las advertencias que aparecen en el extremo superior de la litera y en el empaque. No quite la etiqueta de advertencia de la cama.
- Utilice siempre el colchón del tamaño recomendado, el soporte del colchón recomendado, o ambos, para ayudar a prevenir la probabilidad de quedar atrapado o de caídas.
- Utilice solamente un colchón individual que sea **74" - 75"** de largo y **37½" - 38½"** de ancho en la cama superior y cama inferior.
- Asegúrese de que el grosor del colchón en la cama superior sea mayor a **4"** y que no exceda **6"**.
- La superficie del colchón debe estar por lo menos a **5"(127mm)** por debajo del borde superior de las barandillas.
- No permita que los niños menores de 6 años de edad utilicen la cama superior.
- No permita jugar en o debajo de la cama y prohíba saltar en la cama.
- Prohíba a más de una persona en la cama superior.
- Utilice siempre la escalera para subir y bajar de la cama superior.
- No utilice piezas sustitutas. Entre en contacto con ACE para las piezas de reemplazo.
- El uso de una lámpara de noche puede proporcionar más seguridad para un niño que utilice la cama superior.
- Utilice siempre las barandillas en ambos lados largos de la cama superior. Si la litera es colocada contra la pared, la barandilla lateral debe ser colocada de igual forma contra la pared para prevenir quedar atrapado entre la cama y la pared.
- Se prohíbe el uso de colchones de agua.
- No utilice elevadores para cama con este producto.
- **Peligro de estrangulación:** nunca ate o cuelgue artículos de ninguna parte de la litera que no hayan sido diseñados para utilizar con esta; por ejemplo pero sin limitarse a, ganchos, correas y cuerdas de saltar.
- Guarde estas instrucciones para futura referencia.

# PARTS

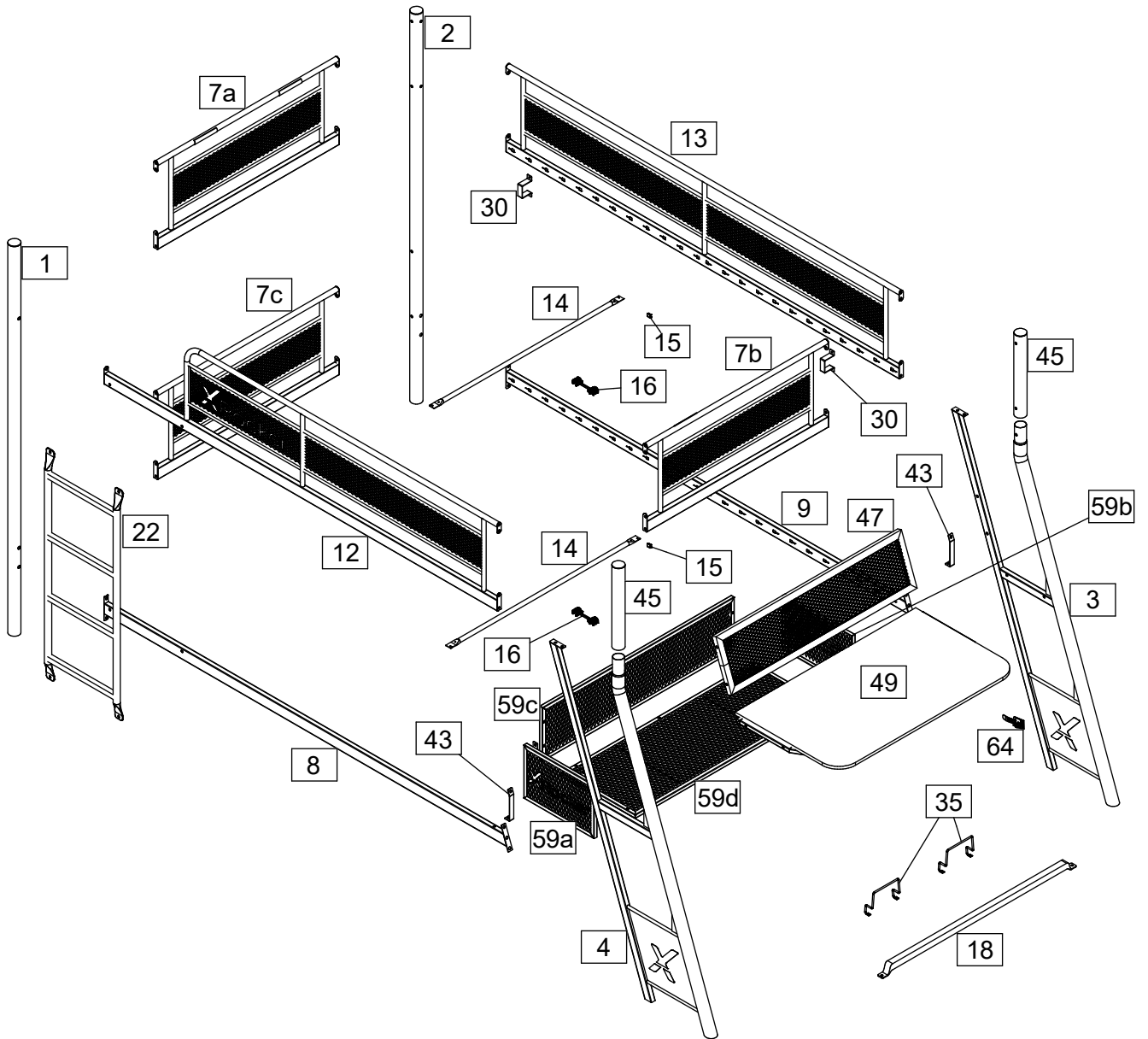



# Panels

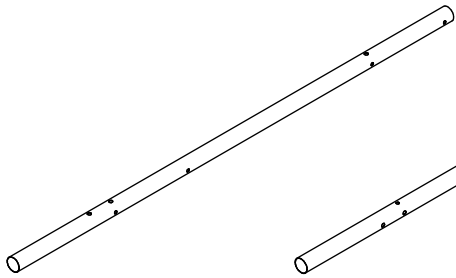

1 Post 01 x 1

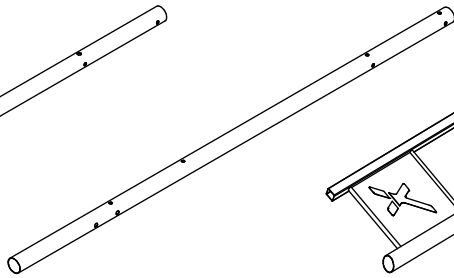

2 Post 02 x 1

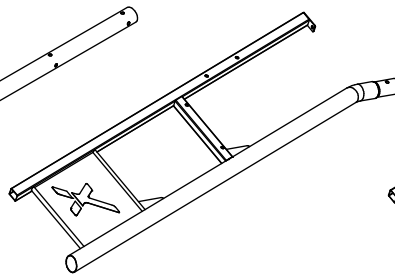

3 Post 03 x 1

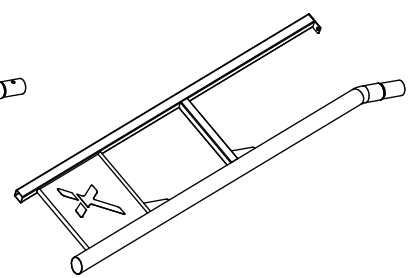

4 Post 04 x 1

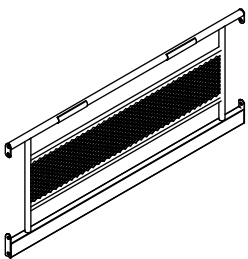

7a End Guard Rail x 1

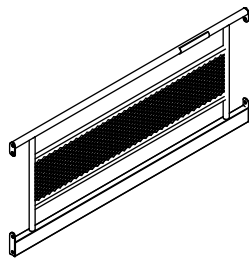

7b End Guard Rail x 1

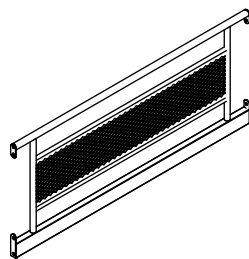

7c End Guard Rail x 1

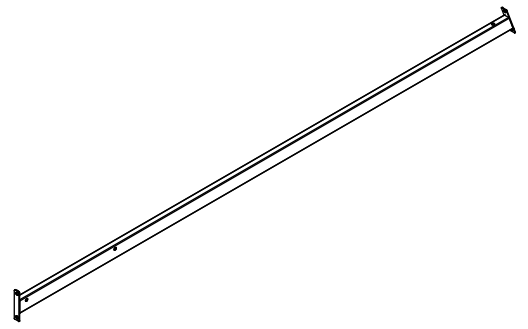

8 Front Rail x 1

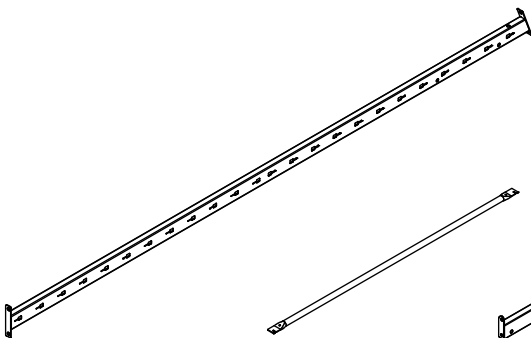

9 Rear Rail x 1

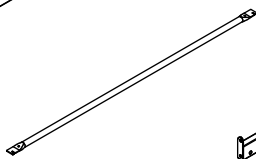

14 Slats x 48

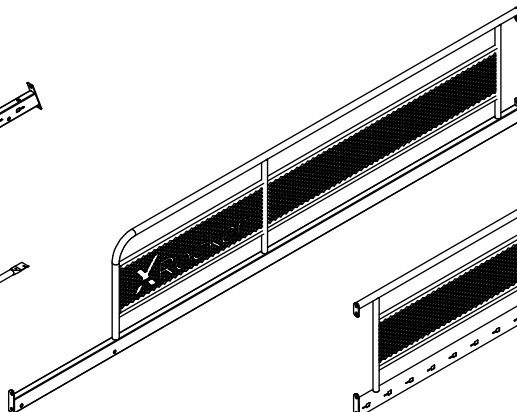

12 Front Guard Rail x 1

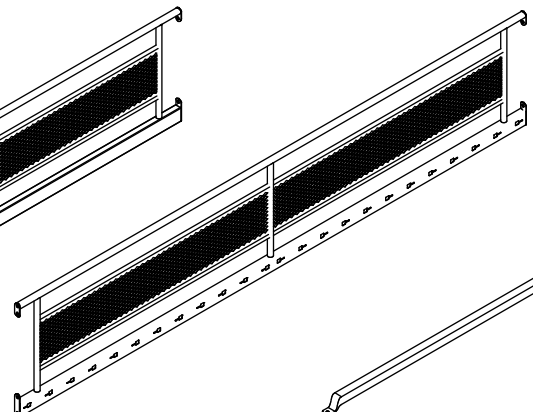

13 Rear Guard Rail x 1

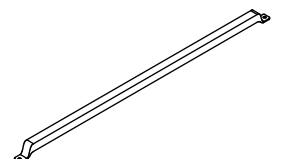

18 Brace x 1

# Panels

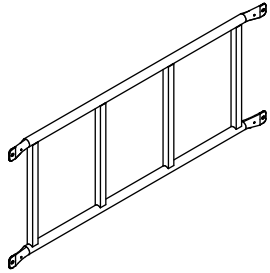

22 Ladder x 1

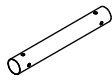

45 Post 05 x 2

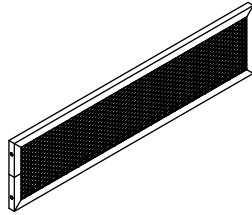

47 Dam-board x 1

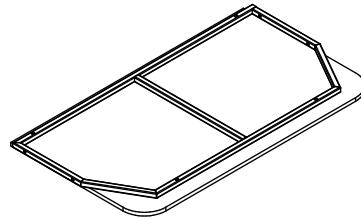

49 Desktop x 1

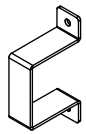

30 Wall Bracket x 2

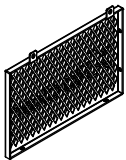

59a Left Mesh Panel x 1

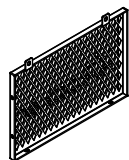

59b Right Mesh Panel x 1

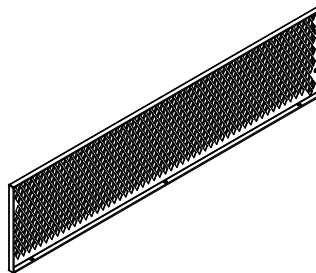

59c Rear Mesh Panel x 1

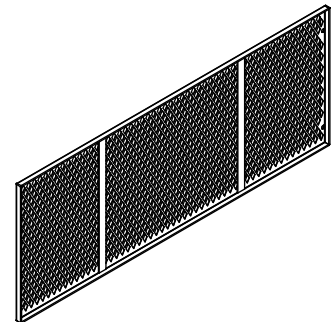

59d Bottom Mesh Panel x 1



15 Plastic Plug x 96

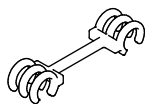

16 Slat Spacer x 46

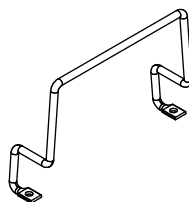

35 Retainer x 2

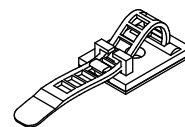





64 Cable Fixing Ribbon x 5

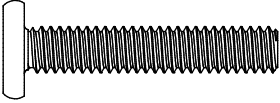
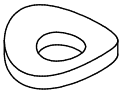
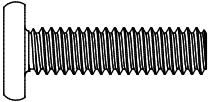
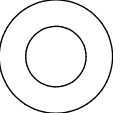
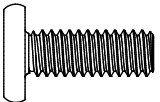
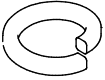
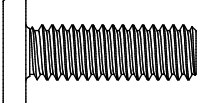

43 Bracket x 2

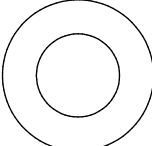
# Fittings (T00012300B00)

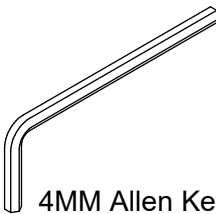
<p><b>A</b></p>  <p>33mm M6 Bolt x 4</p>	<p><b>G</b></p>  <p>M6 Metal Washer x 6</p>
<p><b>B</b></p>  <p>24mm M6 Bolt x 10</p>	<p><b>H</b></p>  <p>M6 Plastic Washer x 6</p>
<p><b>C</b></p>  <p>17mm M6 Bolt x 39</p>	<p><b>I</b></p>  <p>M8 Spring Washer x 9</p>
<p><b>D</b></p>  <p>22mm M8 Bolt x 9</p>	<p><b>J</b></p>  <p>M8 Metal Washer x 9</p>
<p><b>E</b></p>  <p>15mm M5 Bolt X 4</p>	<p><b>K</b></p>  <p>M8 Plastic Washer x 9</p>
<p><b>F</b></p>  <p>M6 Spring Washer x 6</p>	<p><b>L</b></p>  <p>4MM Allen Key x 1</p>

# 1

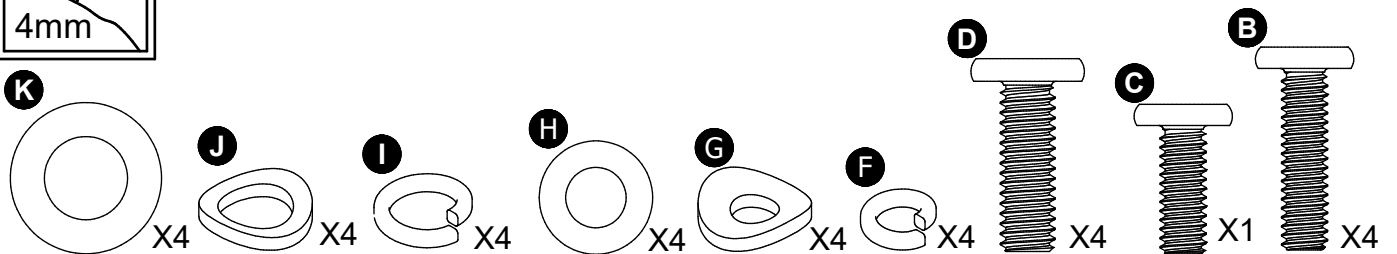
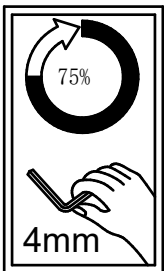
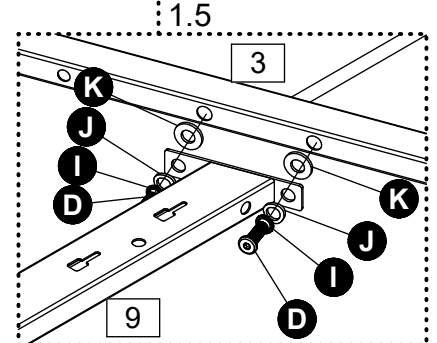
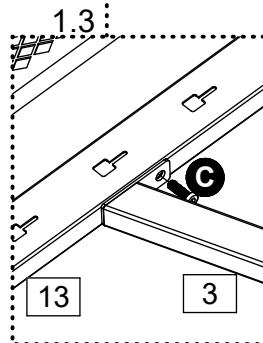
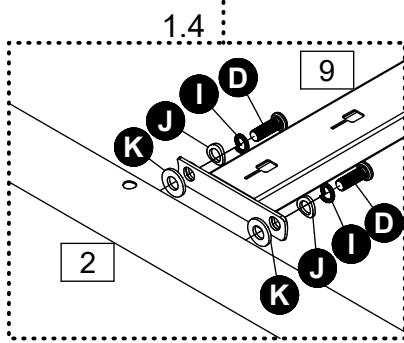
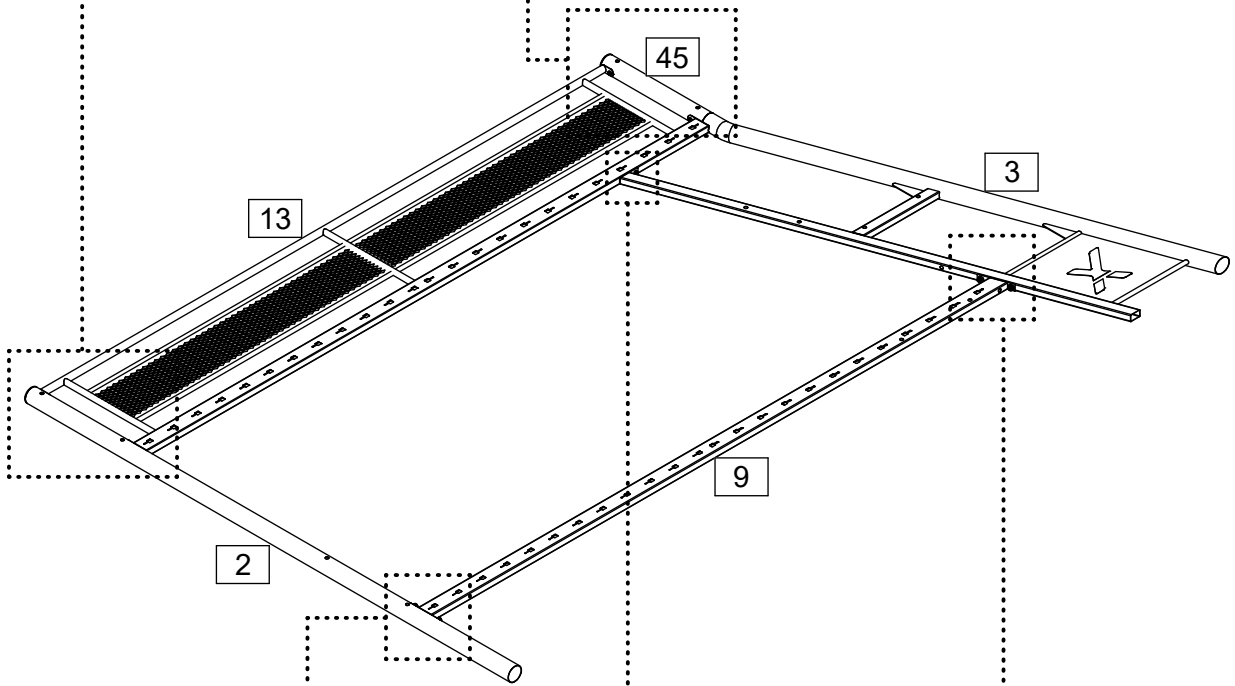
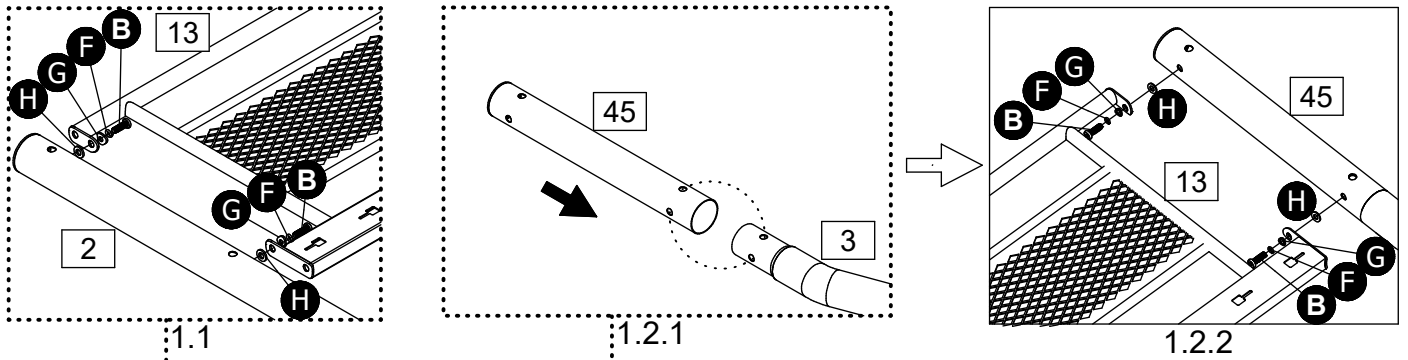

# 2

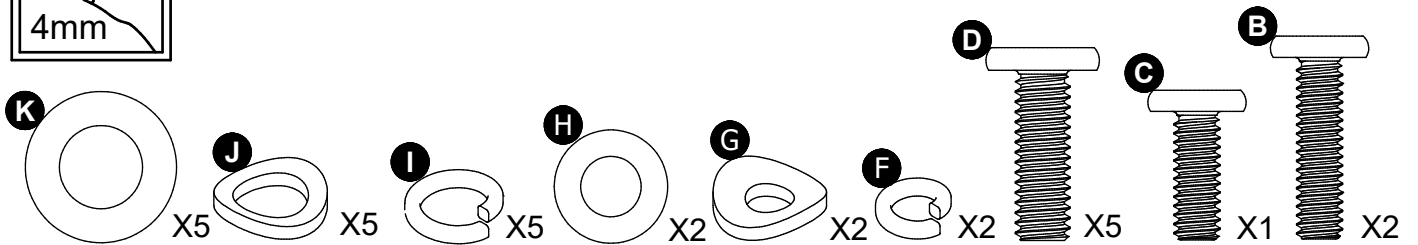
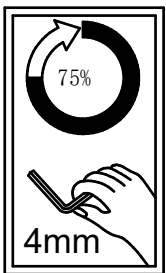
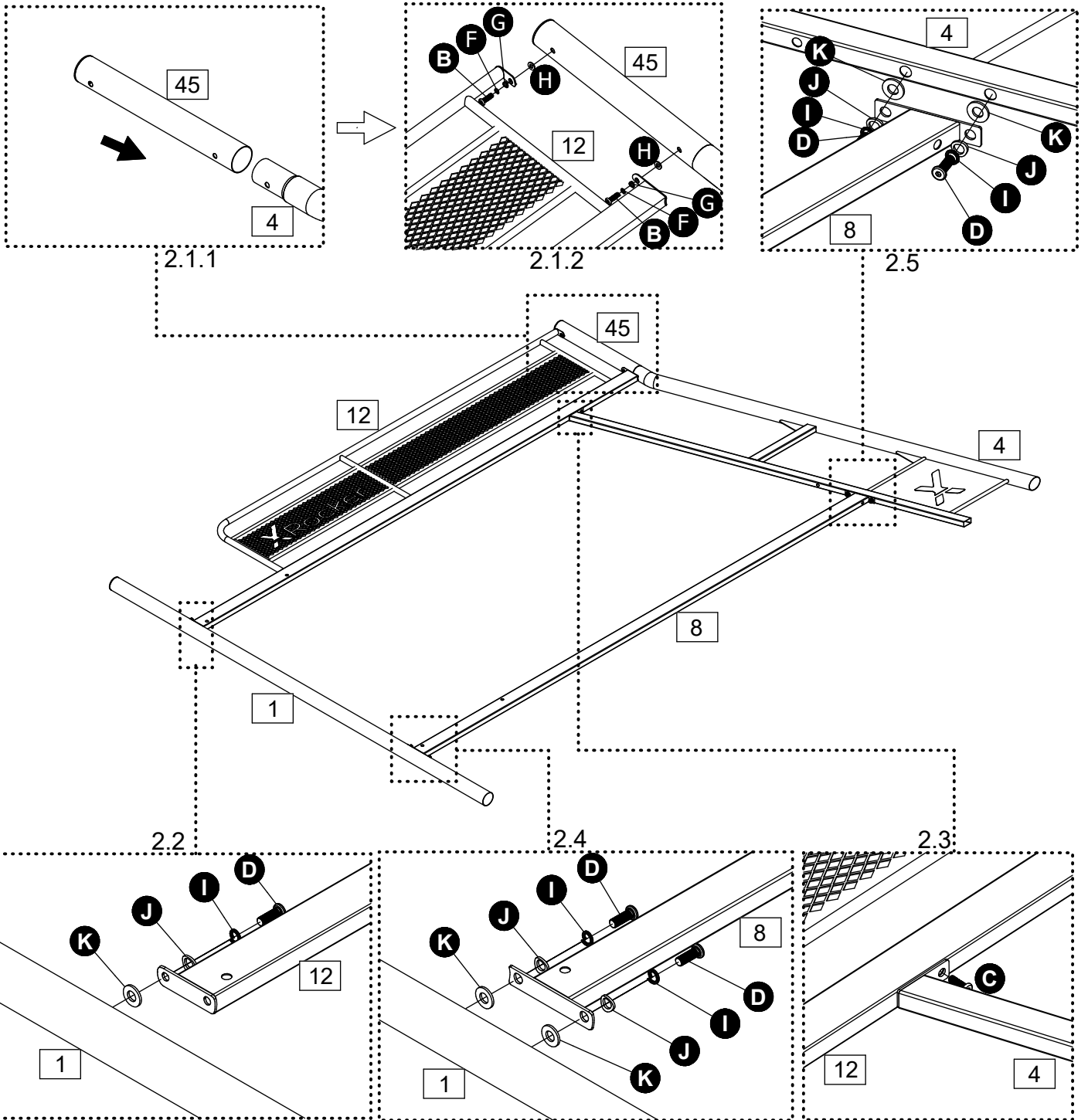

# 3

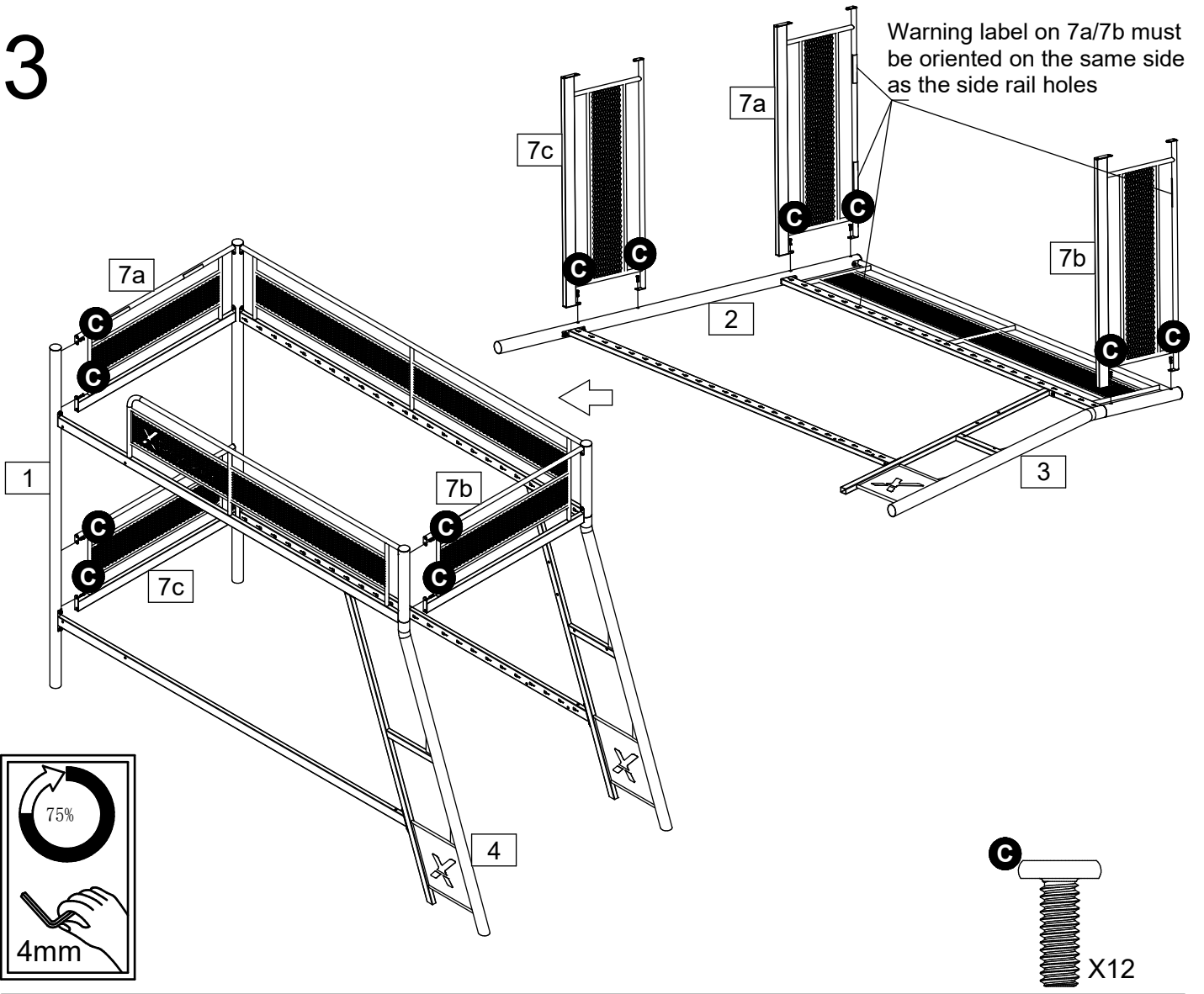

# 4

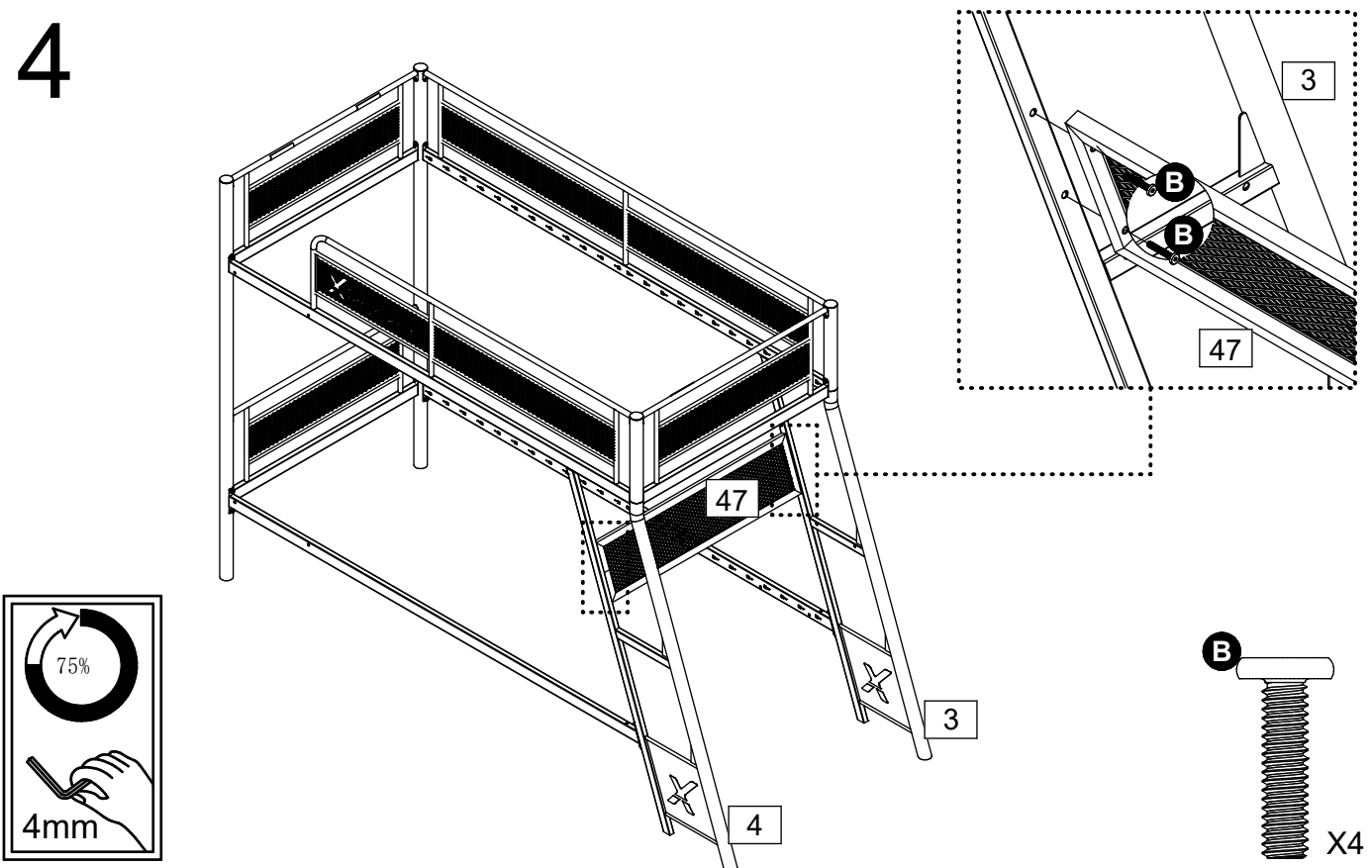

# 5

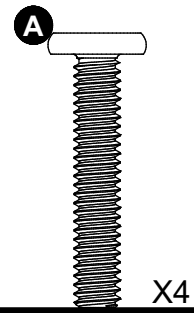
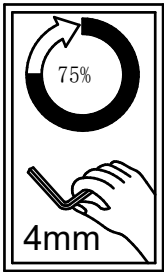
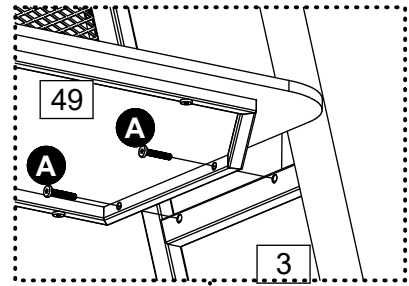
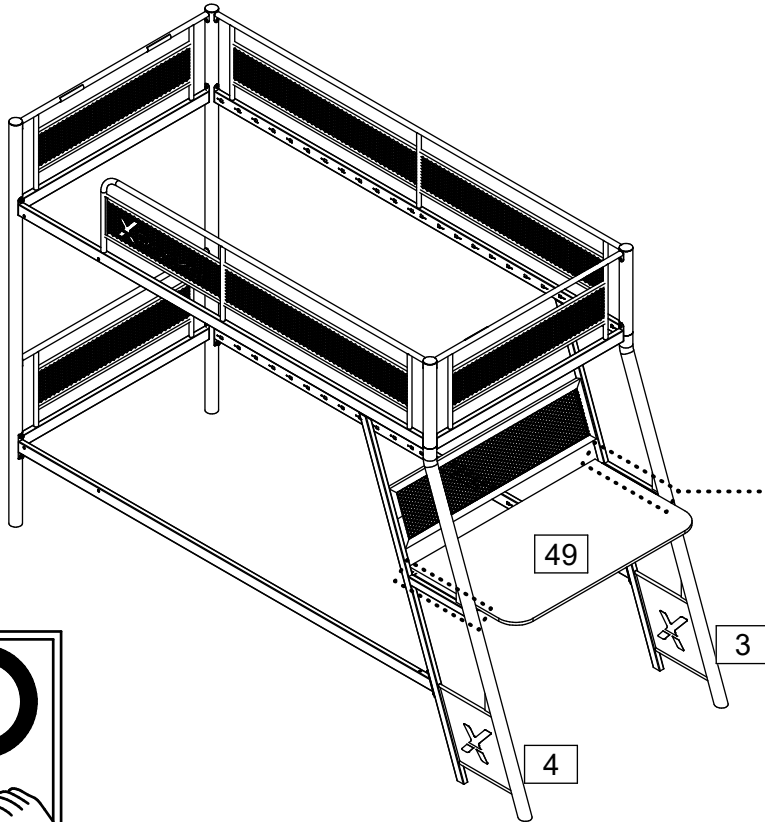

# 6

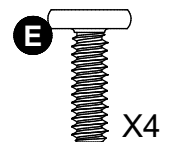
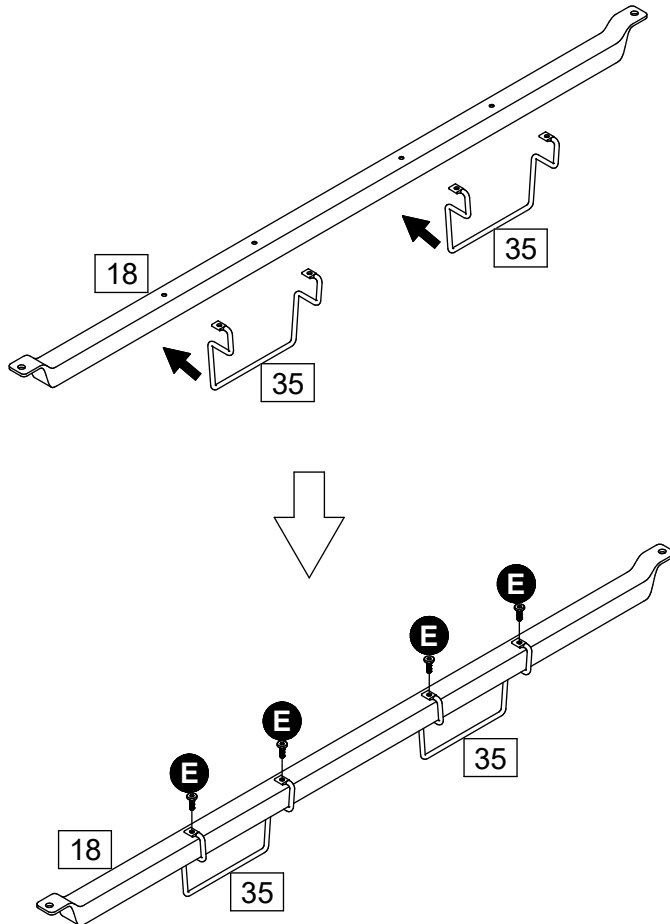

# 7

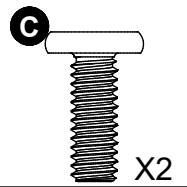
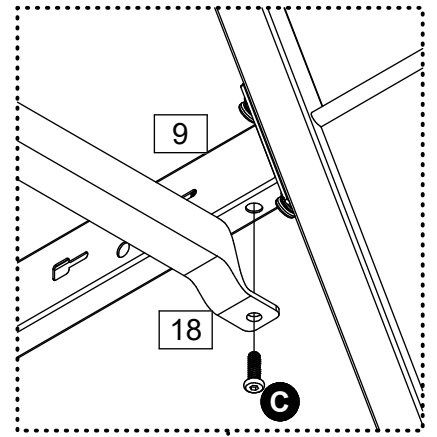
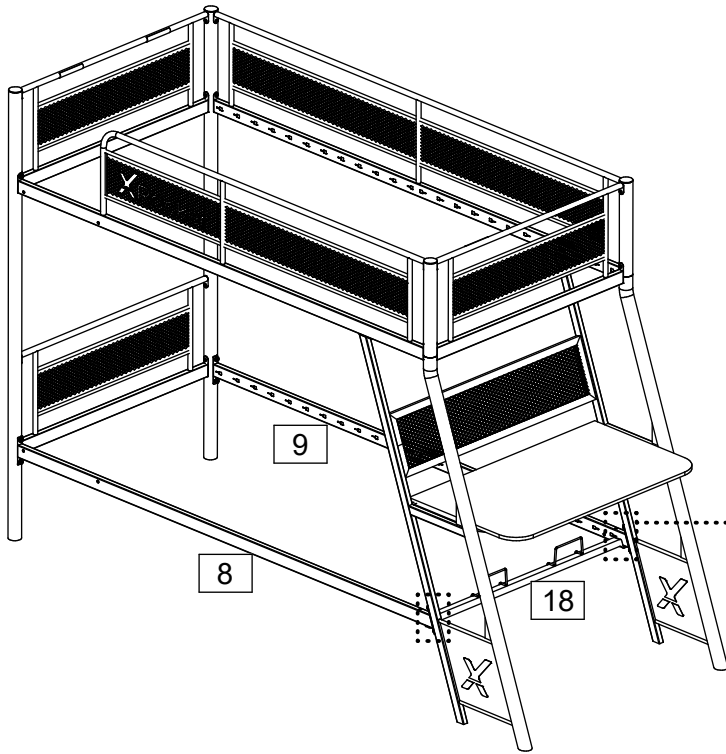

# 8

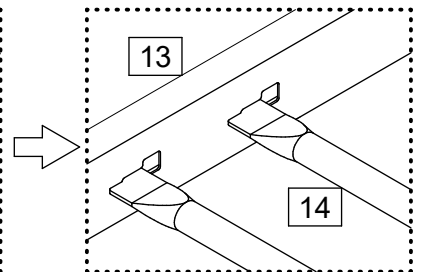
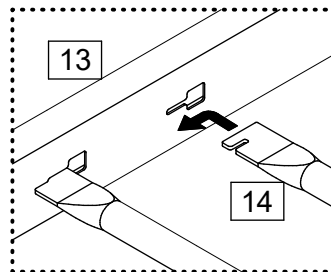
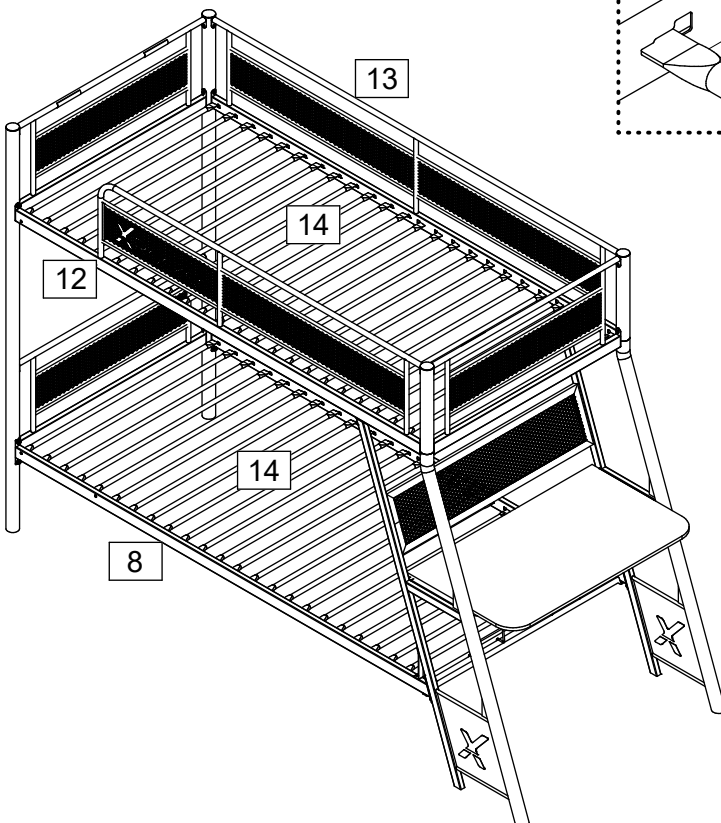



# 9

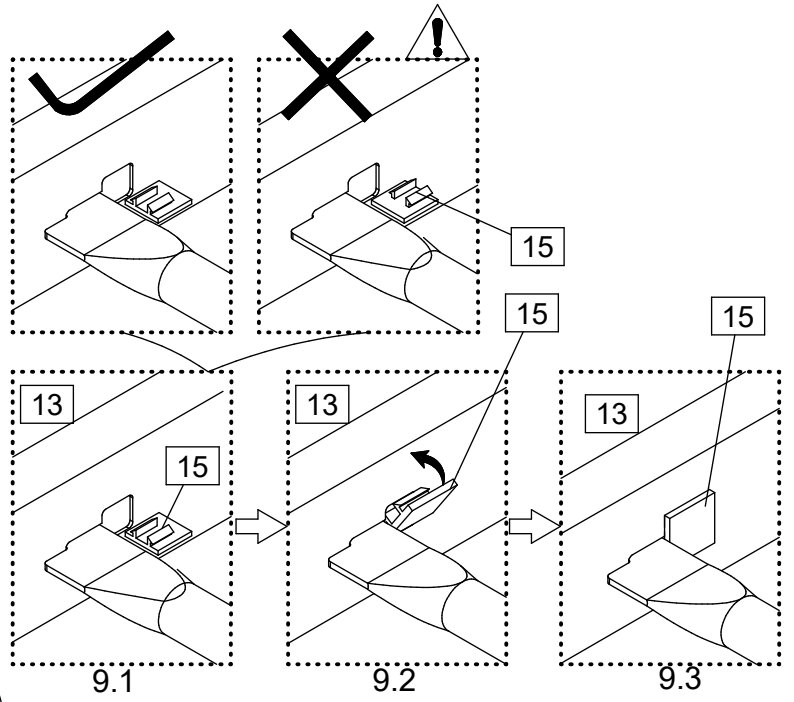
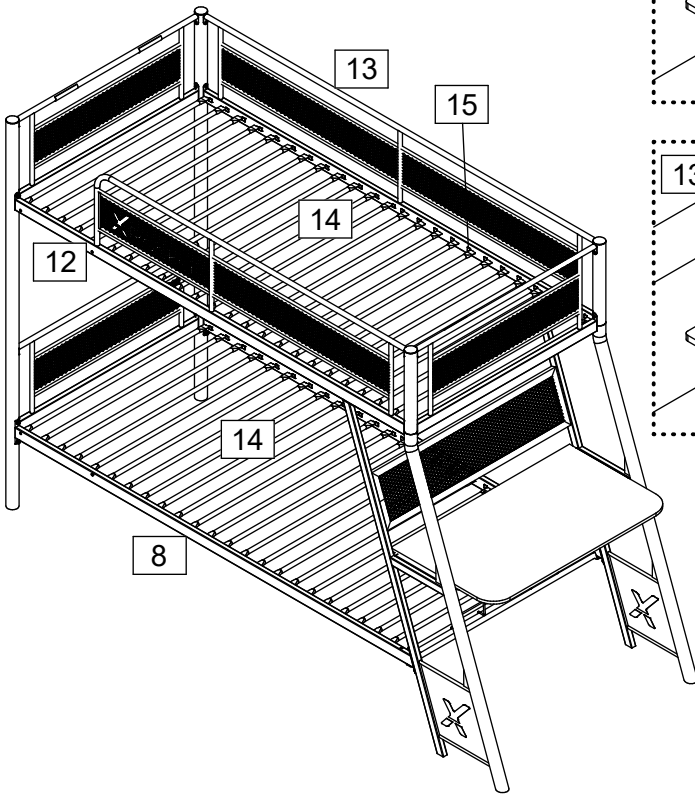

# 10

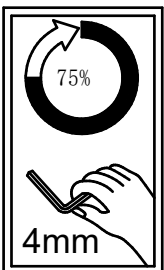
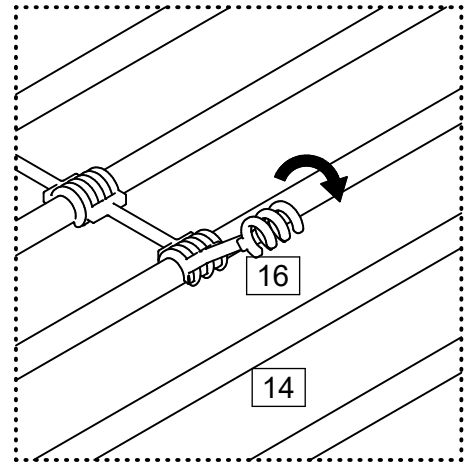
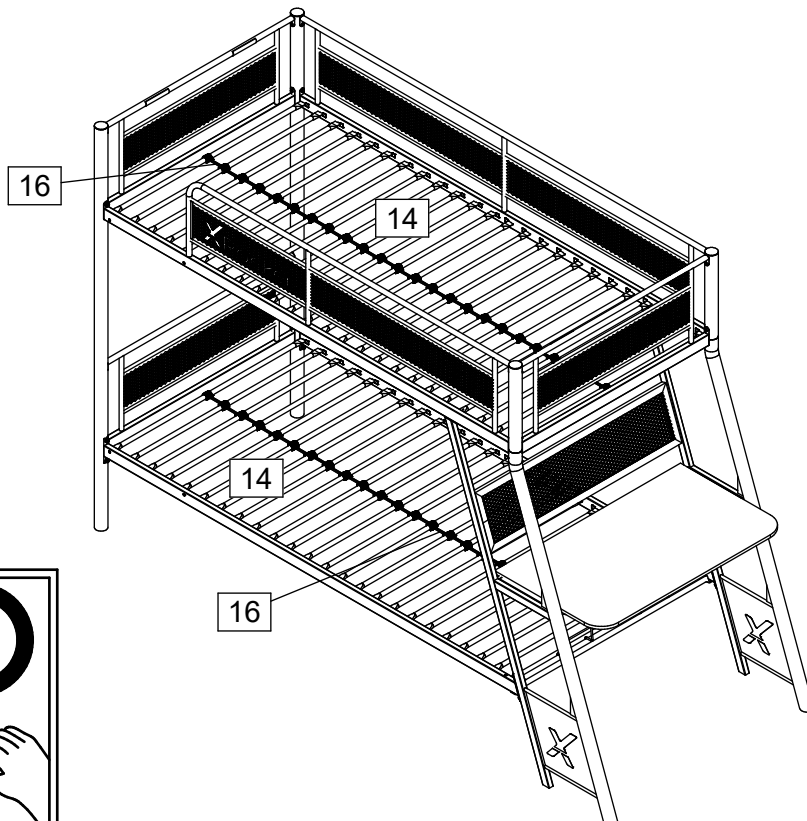

# 11

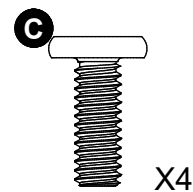
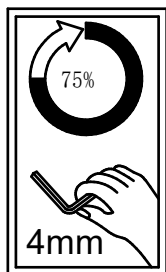
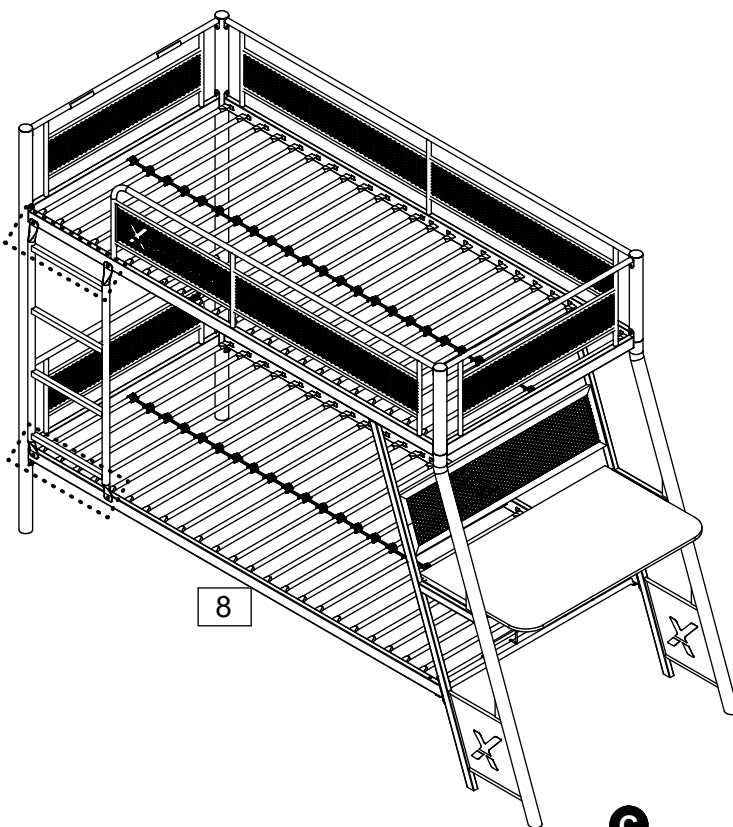
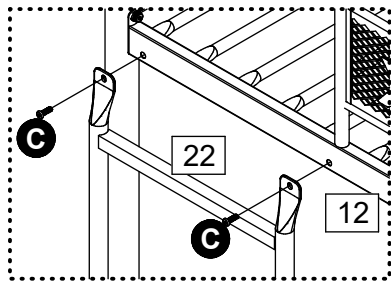

# 12

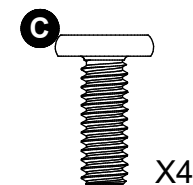
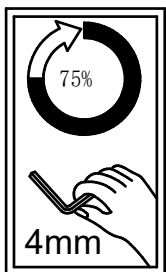
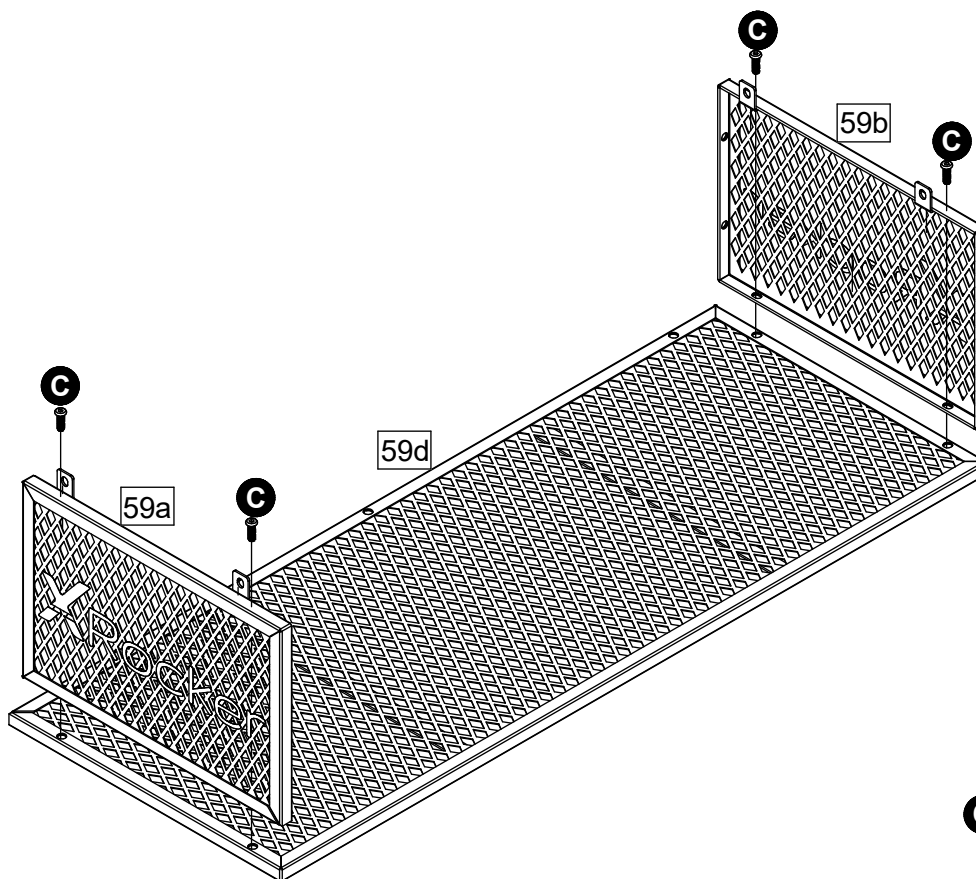

# 13

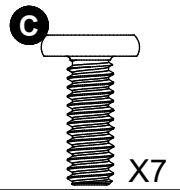
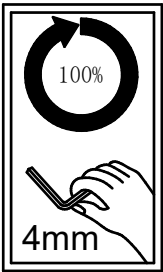
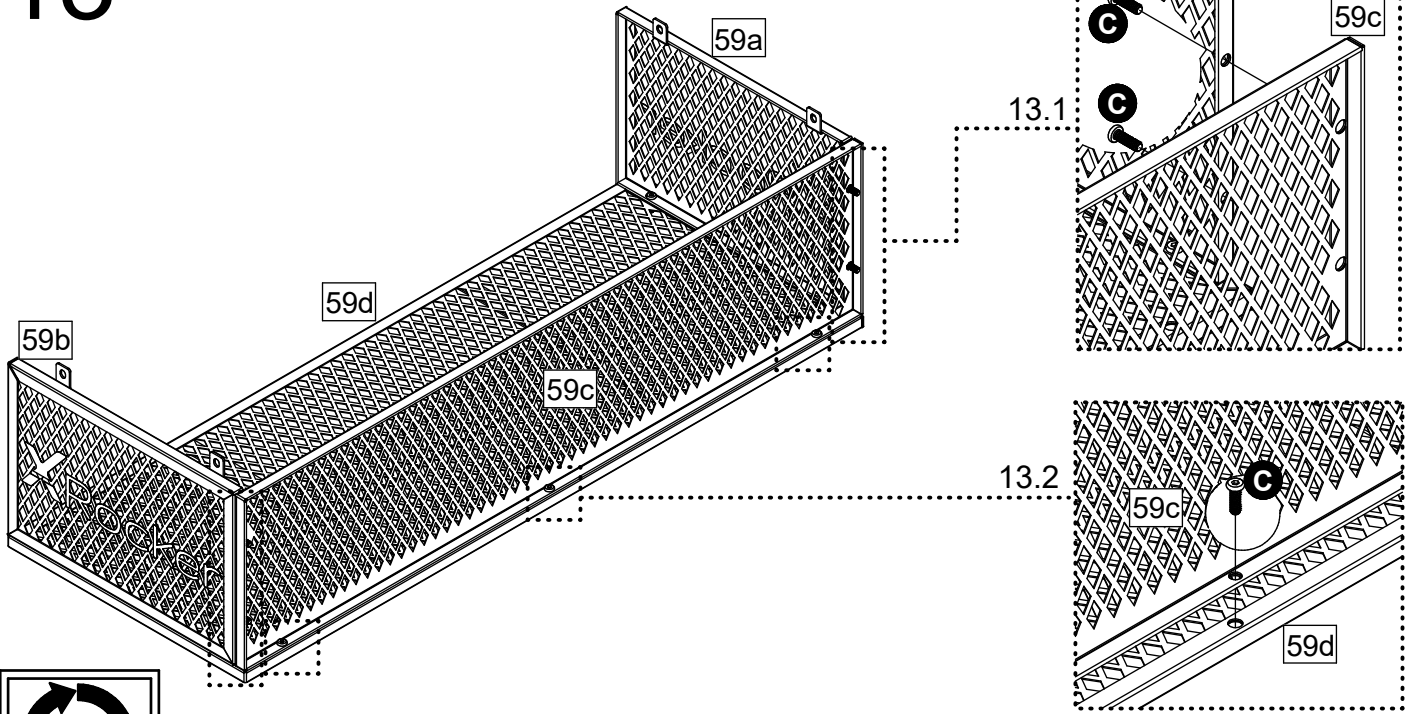

# 14

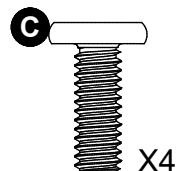
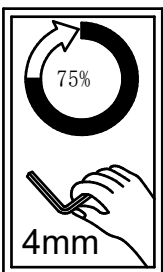
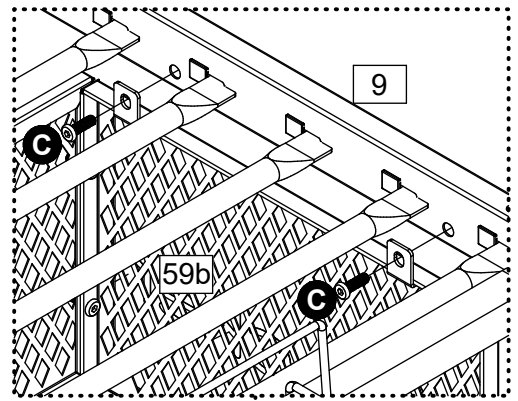
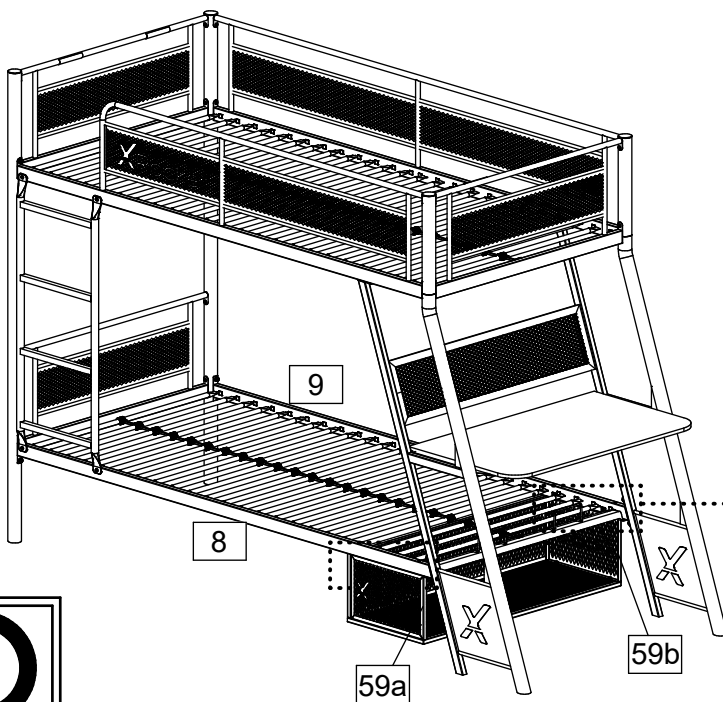

# 15

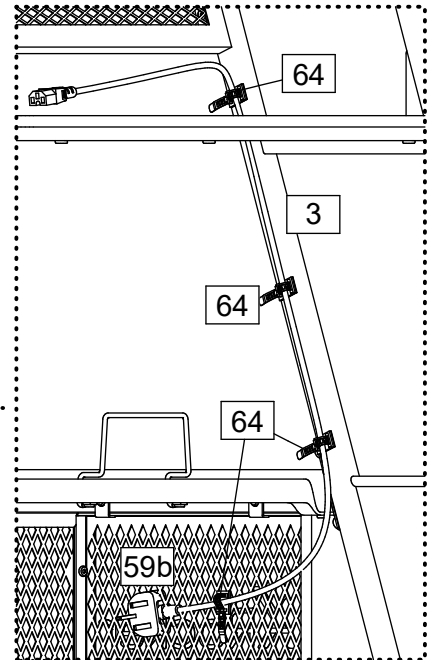
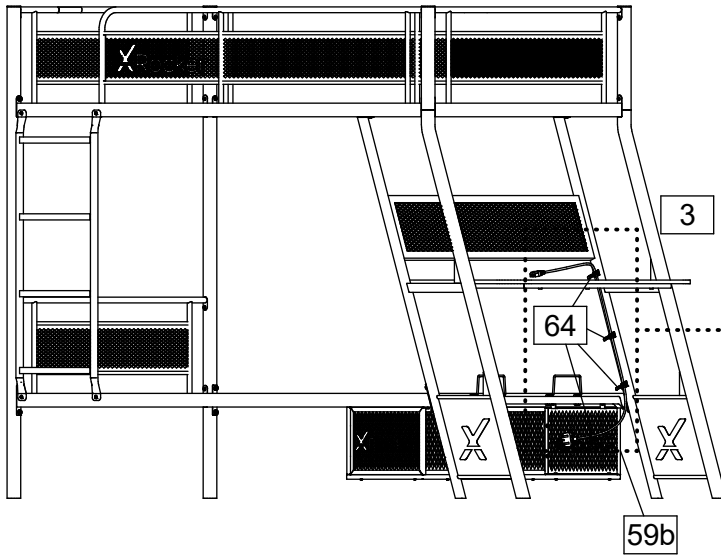
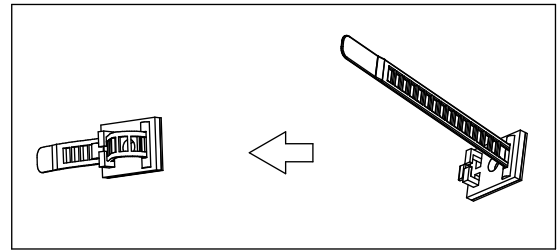

# 16

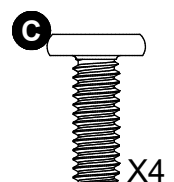
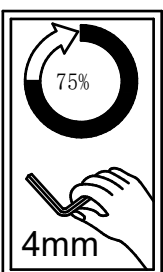
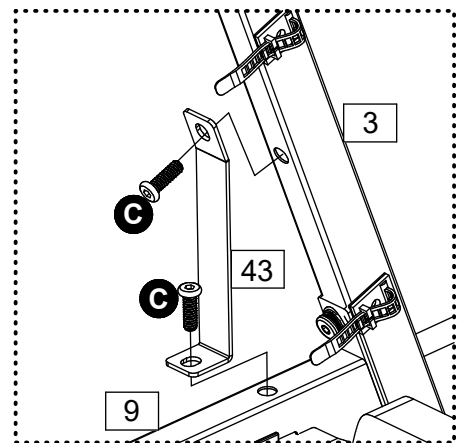
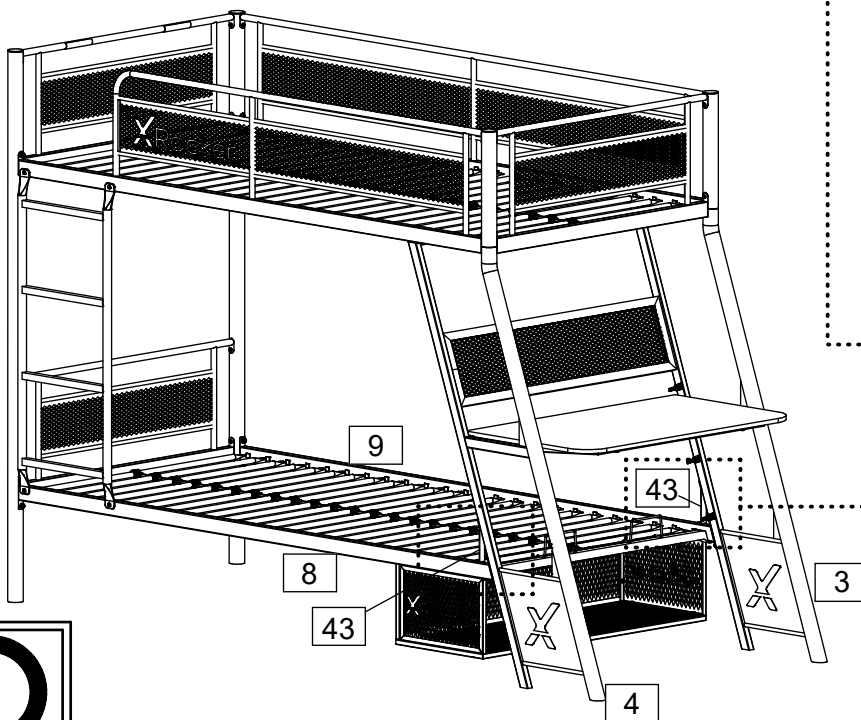

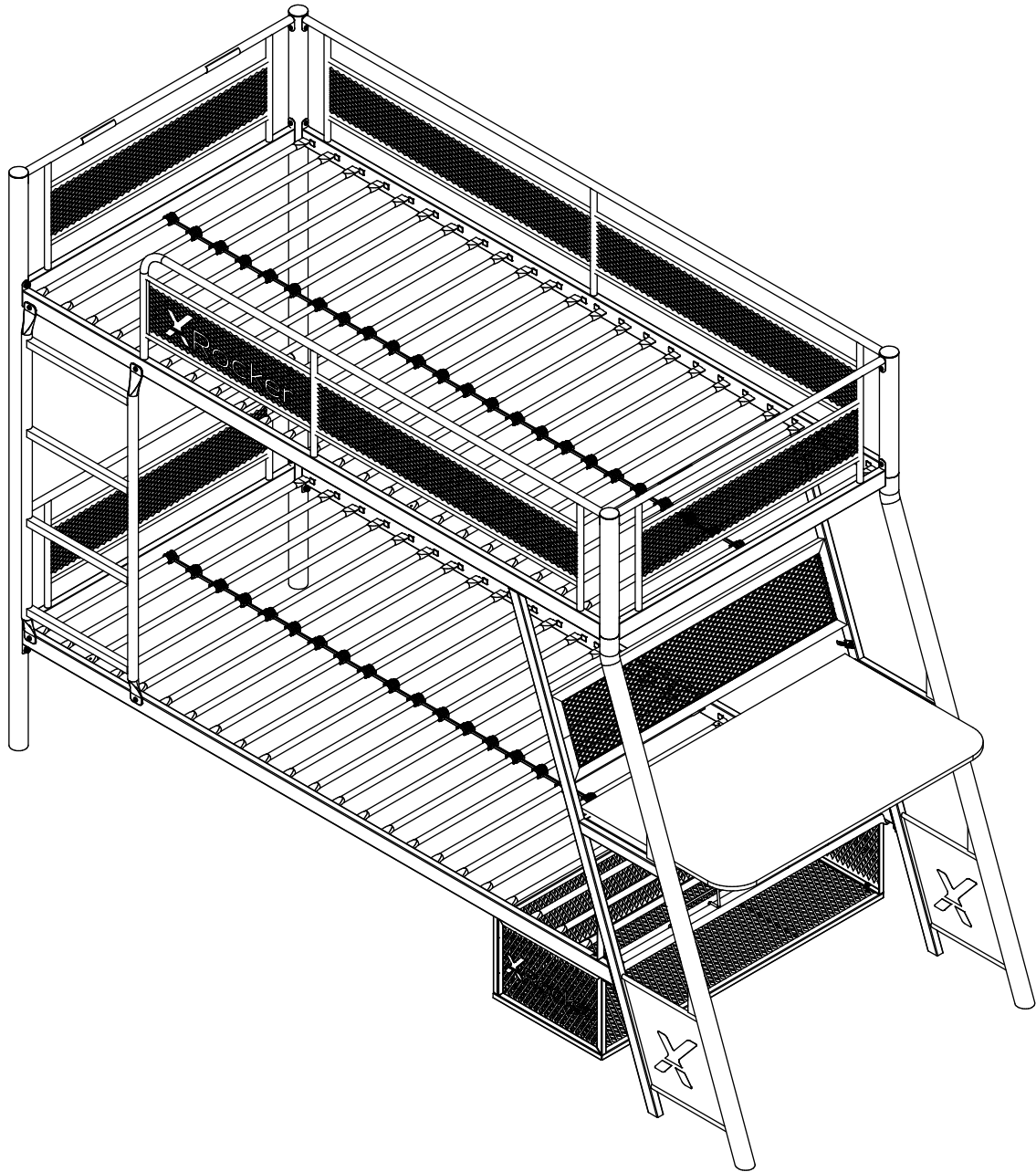

Assembly is complete

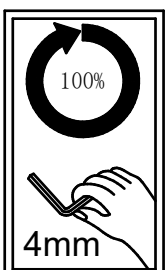

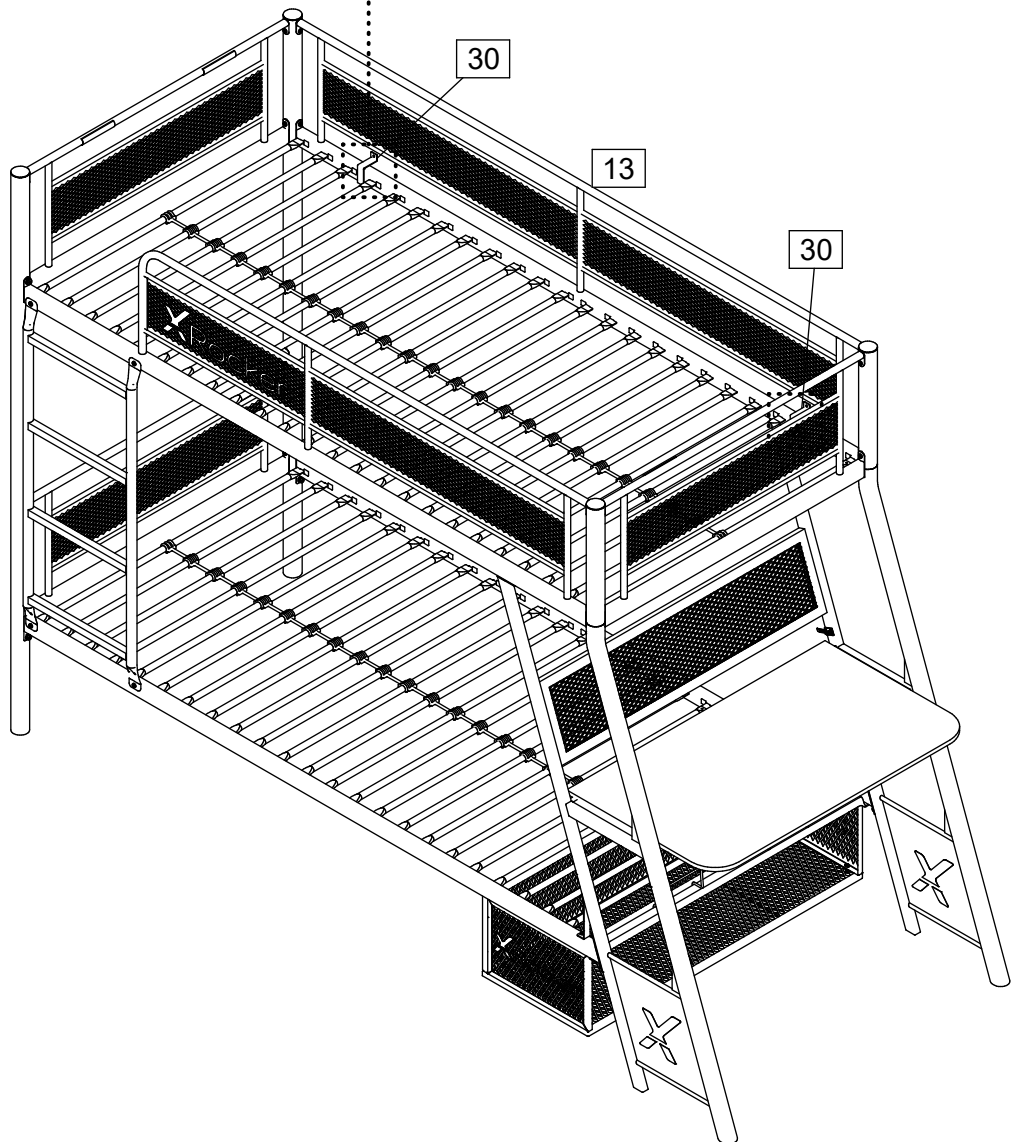
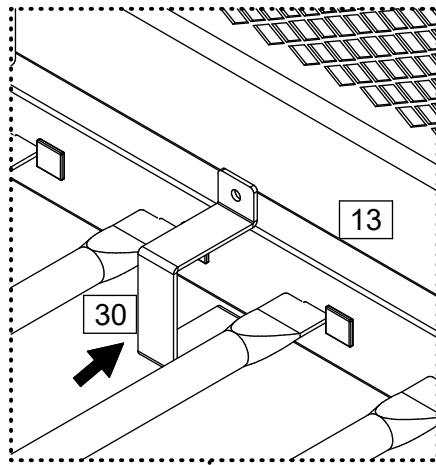

# A Guide to Wall Mounting & Fixings

## Important note:

If plastic wall plugs are supplied with your product:

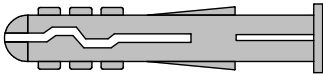

- these are only suitable for use in masonry walls.

If you are in any doubt about the correct wall plugs for your wall, seek professional advice.

Failure of the product due to using incorrect fixings is the responsibility of the installer.

## Important: When drilling into walls always check that there are no hidden wires or pipes etc.

Make sure that the screws and wall plugs being used are suitable for supporting your unit. Consult a qualified tradesperson if you are unsure.

### Hints:

- 1: General rule:  Always use a larger screw and wall plug if you are not sure.
- 2: Ensure you use the recommended drill bit to match the wall plug and hole size.
- 3: Ensure you drill the hole horizontally, do not force the drill or enlarge the hole.
- 4: Take extra care when drilling high walls, ceilings and ceramic tiles. Ensure wall plugs are inserted beyond the thickness of the ceramic tiles to avoid the tiles splitting or cracking.
- 5: Ensure wall plugs are well fitted and are a tight fit in the drill hole

## Types of walls

You can use one of the following types of wall plug if your walls are made of brick, breeze block, concrete, stone or wood.

### No.1 "General Purpose" wall plug

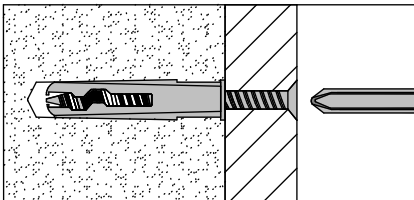

Generally aerated blocks should not be used to support heavy loads, use a specialist fitting in this case. For light loads, general purpose wall plugs can be used.

### No.2 "Plasterboard" wall plug

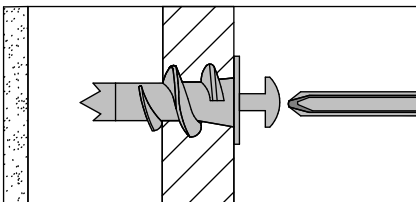

For use when attaching light loads on to plasterboard partitions.

### No.3 "Cavity Fixing" wall plug

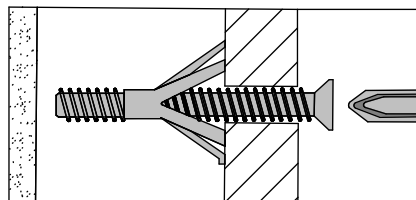

For use with plasterboard partitions or hollow wooden doors.

### No.4 "Cavity Fixing-Heavy Duty" wall plug

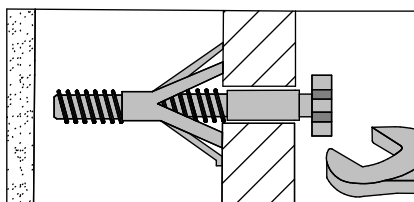

For use when fitting or supporting heavy loads such as shelving, wall cabinets and coat racks.

### No.5 "Hammer Fixing" wall plug

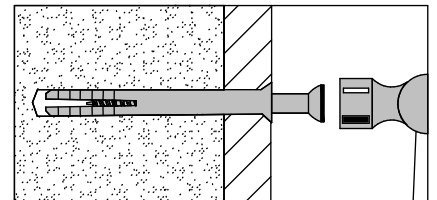

For use with walls stuck with plasterboard. The hammer fixing allows it to be fixed to the wall rather than the plasterboard. Always check the fixing is secure to the retaining wall.

### No.6 "Shield Anchor" wall plug Heavy load

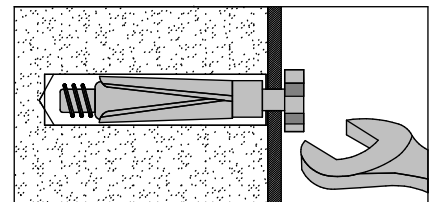

For use with heavier loads such as TV & HiFi speakers and satellite dishes etc.



## Care & Maintenance

**Safety:** Always check the fitting and location to ensure your safety in and around the home.

**Fitting:** From time to time check the fitting to ensure the wall plugs or screws do not become loose.