

INSTALLATION GUIDE

Polaris™ RZR Seat Mount Kit: 6603



Fitment:

Installs driver and passenger side ADS-1 seats into Polaris™ RZR models 2008-current.

PARTS INCLUDED

- | | |
|-------------------------|------------------------|
| 4 1 x 2 Angle Brackets | 16 5/16"-18 Nyloc nuts |
| 16 5/16" Carriage bolts | 8 5/16" Flat washers |

TO ENSURE YOUR SAFETY AND THE SAFETY OF OTHERS AND AVOID PROPERTY DAMAGE OR LOSS, PLEASE PAY CLOSE ATTENTION TO ALL INSTRUCTIONS, WARNINGS, CAUTIONS AND ATTENTION NOTES REGARDING THE USE AND CARE OF THIS PRODUCT.

NOTE: STRICTLY OBSERVE THE FOLLOWING GUIDELINES IN ORDER TO USE THE PRODUCT PROPERLY AND AVOID POTENTIALLY DANGEROUS ACCIDENTS

STEP 1 Remove the stock driver seat and place face-down on a clean surface. Remove plastic seat base using a T-25 Torx driver on four fasteners as indicated (figure 1). NOTE: You will need to activate the slider lever to disengage the lock pin from the adjuster gate. Retain these four fastener assemblies in the same sequence as they were removed.

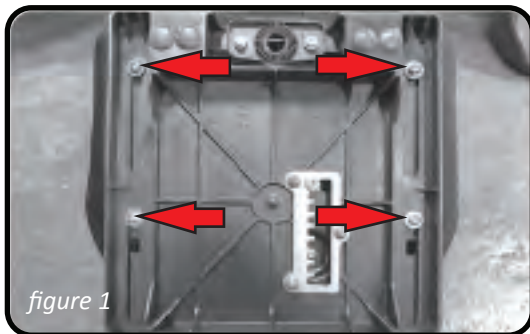

STEP 2 Next remove the four fasteners attaching the bottom pan assembly using the same T-25 Torx driver to free the seat slider plate (figure 2). These fasteners will not be re-used. You may now set remaining stock seat parts aside and place your Torque V2 seat face-down on the same clean work space.

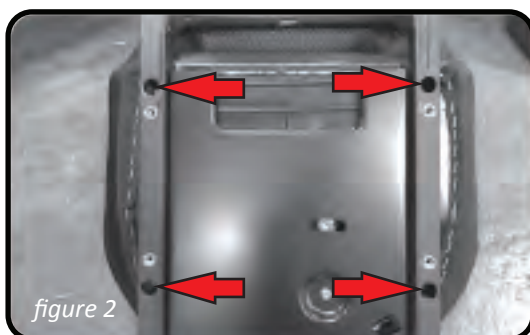

STEP 3 Insert a 1" carriage bolt through each of the slots in the seat frame, so that the round bolt head is on the lacing-side of the seat and the threaded end protrudes out (figure 3).

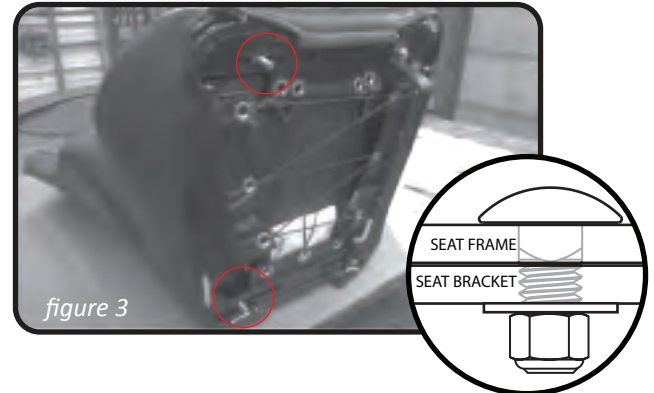

STEP 4 Place one angle bracket over each set of bolts, positioning the 2" rise (taller end) to the front of the seat as indicated (figures 3 & 4). The brackets should be centered on the seat frame, spaced 8" apart and with a washer and nyloc nut, tightened fully (diagram 1). NOTE: Figure 5 illustrates the stock items that will be re-installed in the following steps.

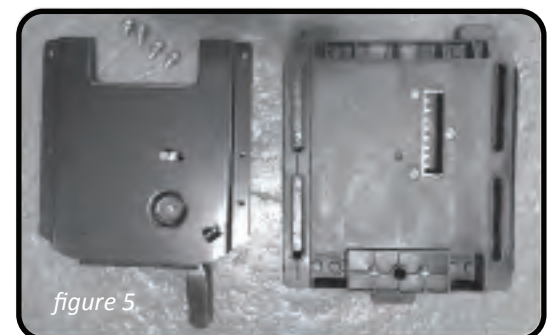
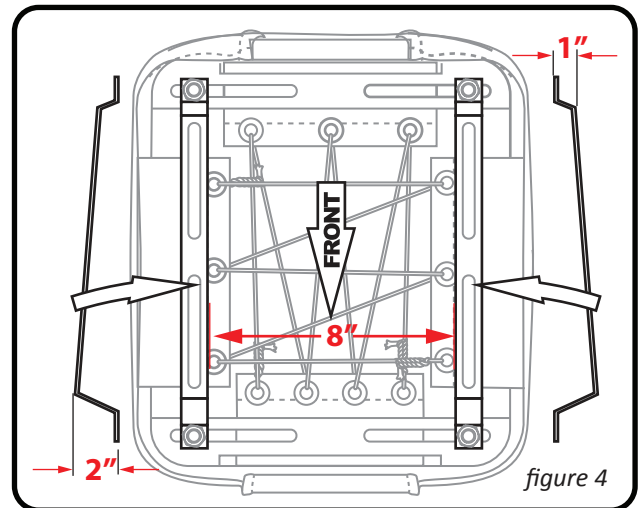

Refer to this diagram for steps 5 through 7.

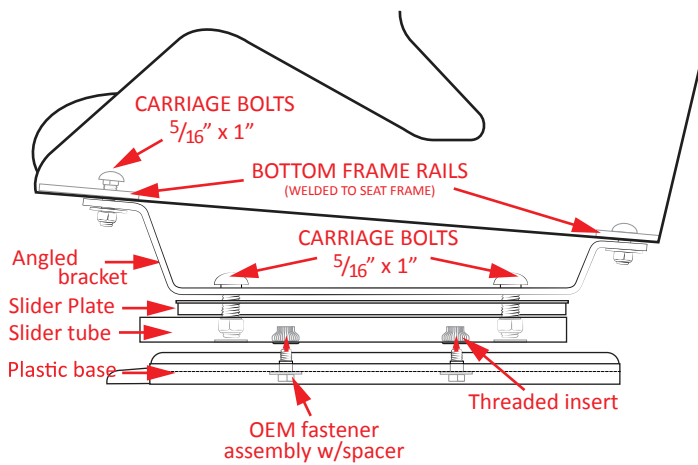

STEP 5 One at a time, install four of the 5/16" carriage bolts down through the slots in the angled brackets, position the slider plate on top, then the slider tube as shown with the long section forward. Start a nyloc nut on each carriage bolt, but do not tighten fully (*figure 6*).

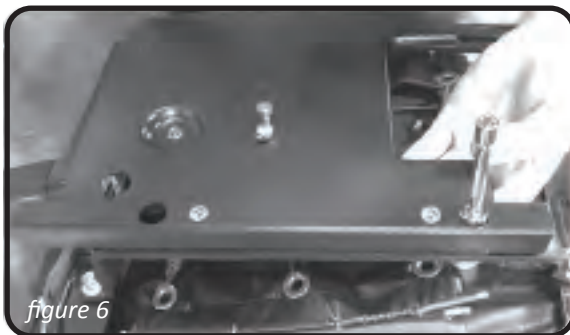

STEP 6 With all four nyloc nuts started, ensure that the slider plate/tube assembly is square on the seat and positioned to the back of the seat, then tighten each through-tube nut securely (*figure 6*).

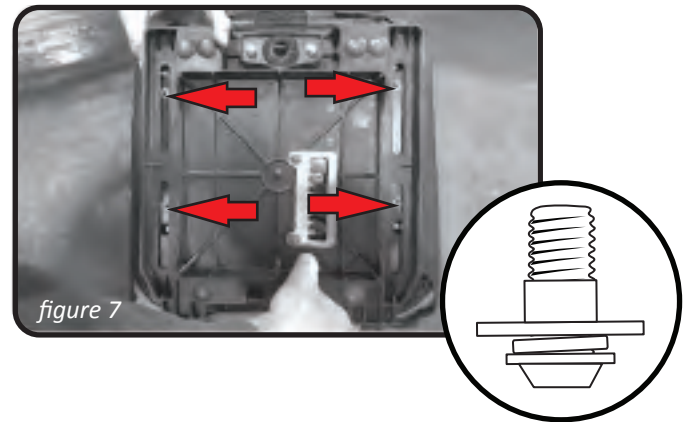

STEP 7 Next, position the plastic base onto the assembly, actuating the slider lever to engage the locking pin with the adjuster gate, and secure with the stock fastener assemblies retained from STEP 1 (*figure 7*).

STEP 8 Install your new Force-1 seat into the vehicle as you would the stock seat and repeat steps 1 through 7 for the passenger side.

NOTE: For applications where slider mechanism is not present or not to be used, skip steps 5 and 6 and re-mount the plastic base directly to the angled brackets.