



INSTALLATION INSTRUCTIONS

SKU: **SP-A080F**

FRONT A-ARM GUARDS CAN-AM OUTLANDER G2 (2019+)

01

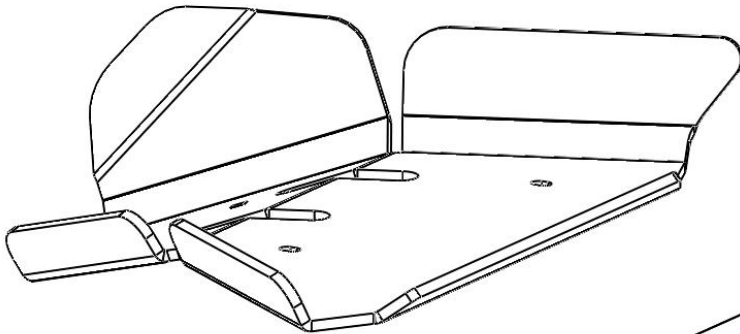

02

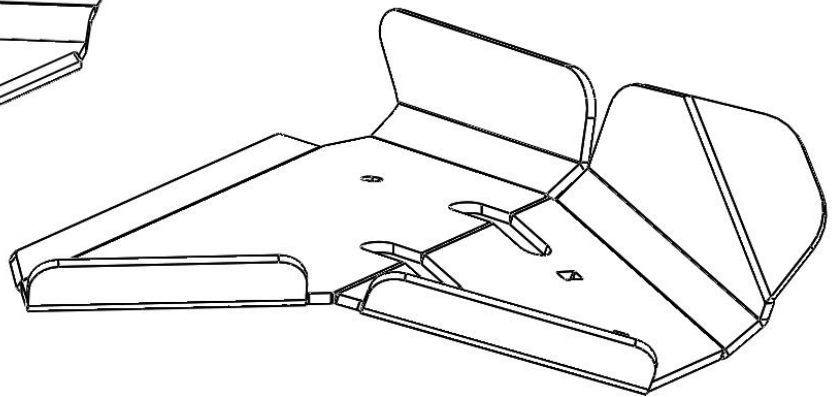

SAFETY WARNING

Please **read and understand** all instructions and safety warning prior to install the product. Failure to do so could result in product damage, personal injury or even death.

- Stay alert! Watch what you are doing and use common sense while handling this product.
- Inspect product for damage prior to installation, do not use if product is in unsafe condition.
- Do not install product while under the influence of drugs, alcohol or medication.
- Always use safety equipment to prevent injuries. Approved face and eye protection must always be worn by the installer, as well as others in the work area.
- Do not over reach. Keep proper footing and balance at all times.
- Dress properly. Do not wear loose clothing or jewelry. Keep your hair, clothing and gloves away from moving parts.
- Keep your work area clean and well lit.

Item	Part No.	Description	Qty.
COMPONENTS			
Those items are shown on the first page.			
01	A080-01	Front Left Aluminum A-arm Guard	1
02	A080-02	Front Right Aluminum A-arm Guard	1
HARDWARE			
Those items are included with each kit to install components.			
03	A-1005	M6 Flat Fender Washer	4
04	A-1505	M6-1.00 Flange Lock Nut	8
05	A-2605	M6-1.00 x 20mm Hex Flange Bolt	4
06	A-2658	M6-1.00 x 20mm Carriage Bolt	4
07	A-4001	Rubber Strip / Adhesive Back, 1x2" x 1/8" Thick	4
08	A-4014	1" Rubber Clamp / 0.281-hole dia.	4

INSTALLATION INSTRUCTIONS

PREPARATION

- Using a jack under center of front end, lift until the front wheels leave the ground.
- Remove the wheels.
- Remove the factory plastic A-arm guards.
- Using the image below as a guide, insert and pinch the rubber clamps on the a-arm, on each side.
- Stick the rubber strips on the a-arm guards. **See image below.**

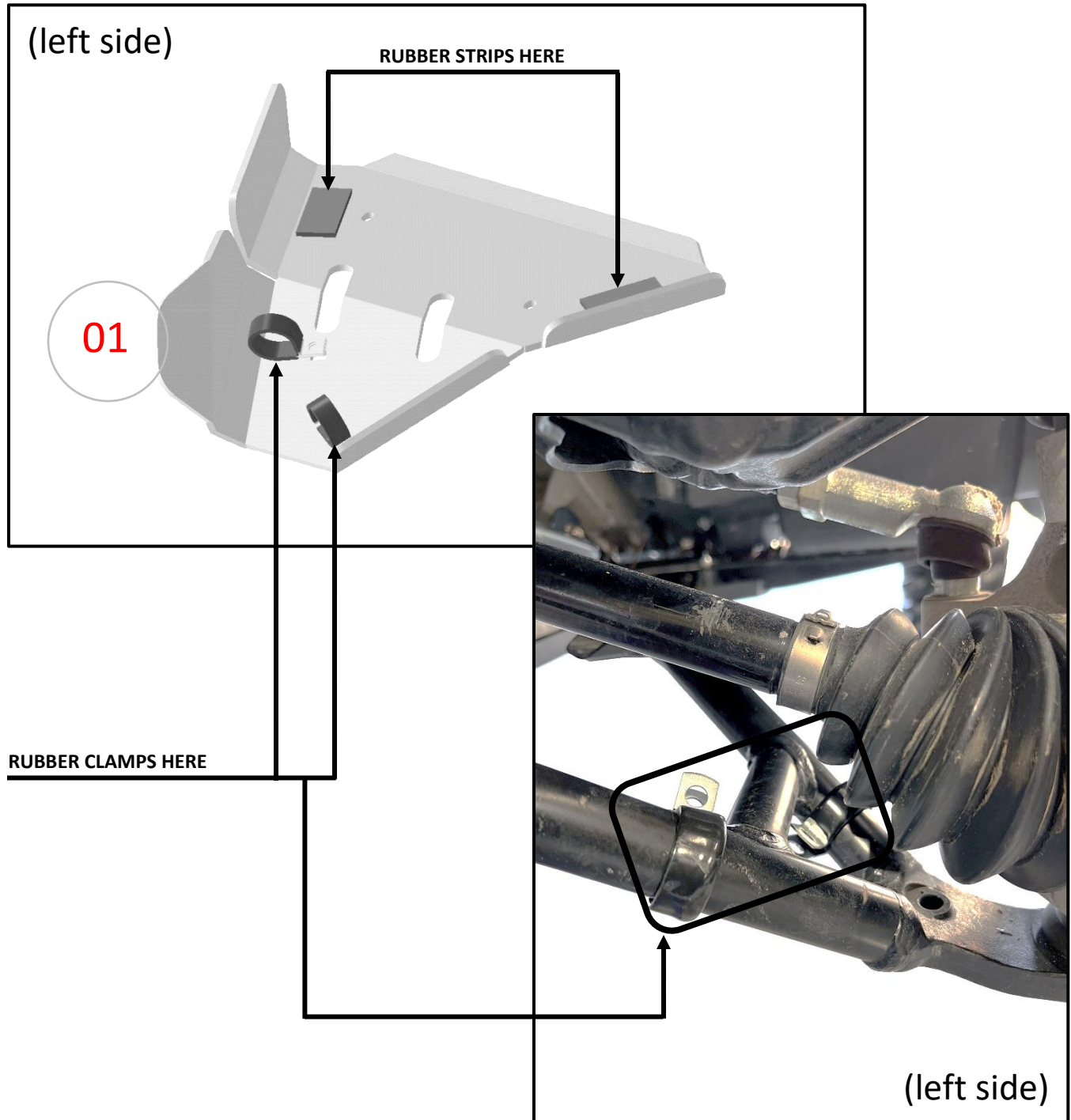

INSTALLATION

1. Install the guards to the suspension arms. Use the M6x20mm hex flange bolts, M6 washer and M6 lock nuts to secure the guards to the arms.

NOTE: Put the washers with the lock nuts, over the mounting points on the A-arms.

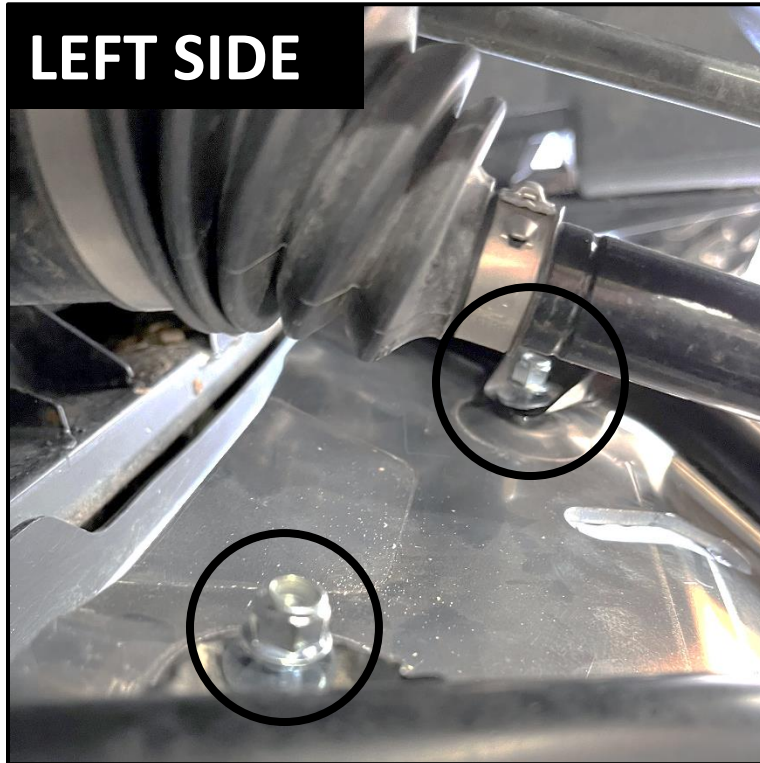

2. Secure the bottom of the guards to the rubber clamps. Use the M6x20mm carriage bolts and M6 lock nuts.
3. Tight all the hardware appropriately once the guards are correctly installed.
4. Put the wheels back on the ATV. Torque all lugs to factory specification.

NOTE: Check that the a-arm guards will clear the others components of the ATV. Re-adjust the guards if it's necessary.

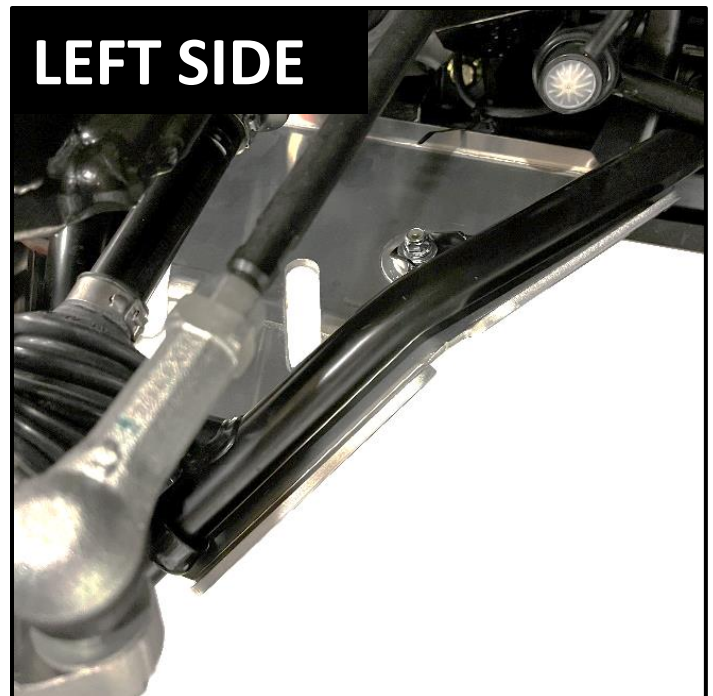



INSTALLATION INSTRUCTIONS

SKU: **SP-A080R**

REAR A-ARM GUARDS CAN-AM OUTLANDER G2 (2019+)

01

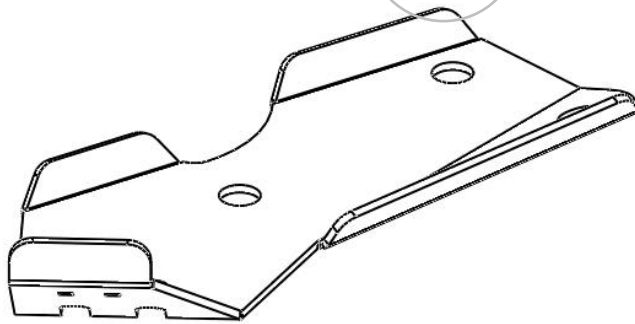

02

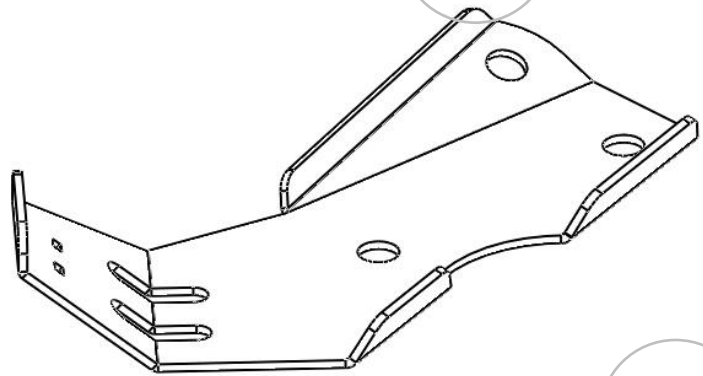

12

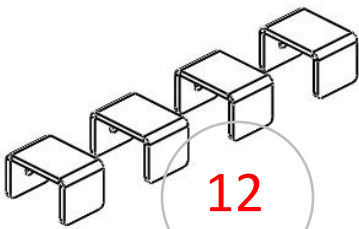

13



14

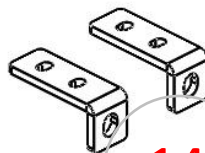

SAFETY WARNING

Please **read and understand** all instructions and safety warning prior to install the product. Failure to do so could result in product damage, personal injury or even death.

- Stay alert! Watch what you are doing and use common sense while handling this product.
- Inspect product for damage prior to installation, do not use if product is in unsafe condition.
- Do not install product while under the influence of drugs, alcohol or medication.
- Always use safety equipment to prevent injuries. Approved face and eye protection must always be worn by the installer, as well as others in the work area.
- Do not over reach. Keep proper footing and balance at all times.
- Dress properly. Do not wear loose clothing or jewelry. Keep your hair, clothing and gloves away from moving parts.
- Keep your work area clean and well lit.

Item	Part No.	Description	Qty.
COMPONENTS			
Those items are shown on the first page.			
01	A080-03	Rear Left Aluminum A-arm Guard	1
02	A080-04	Rear Right Aluminum A-arm Guard	1
HARDWARE			
Those items are included with each kit to install components.			
03	A-1505	M6-1.00 Flange Lock Nut	12
04	A-1509	M10-1.50 Flange Lock Nut	1
05	A-1205	M6 Cup Washer	6
06	A-2602	M6-1.00 x 16mm Hex Bolt	4
07	A-2605	M6-1.00 x 20mm Hex Flange Bolt	2
08	A-2607	M6-1.00 x 25mm Hex Flange Bolt	2
09	A-2658	M6-1.00 x 20mm Carriage Bolt	4
10	A-3006	M10-1.50 x 25mm Hex Bolt	1
11	A-3008	M10-1.50 x 30mm Hex Bolt	
12	B-5611	Clamp	4
13	B-5612	Mounting Clamp	2
14	B-5613	Mounting Clamp	2

INSTALLATION INSTRUCTIONS

PREPARATION

- Using a jack under center of rear end, lift until the rear wheels leave the ground.
- Remove the wheels.
- Remove both factory plastic A-arm guards.

INSTALLATION

5. Install the clamps (14) to the suspension arms. Use the M10 bolts (2x) and M10 lock nut (1x). See image below.
NOTE: The bolt on the right side will be bolted into the brake caliper.

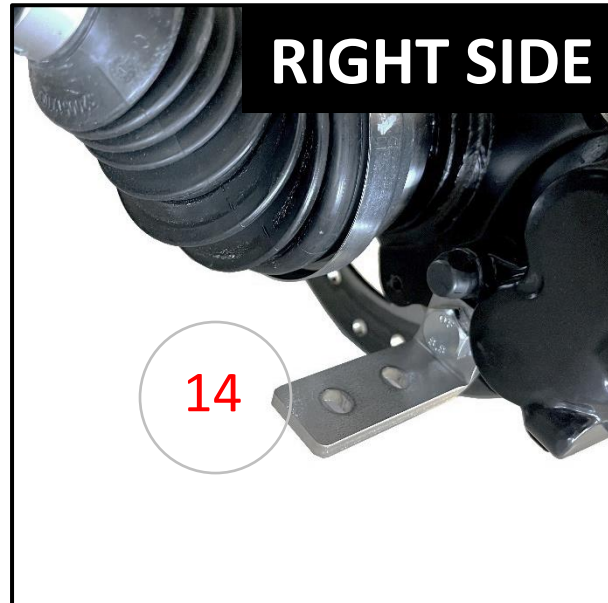
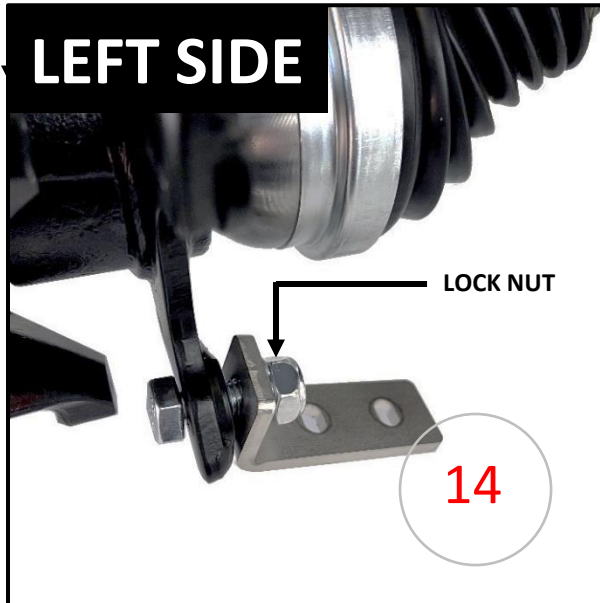

6. Install the clamps (13) to the suspension arms. Use the M6x25mm bolts (2x) with M6 lock nuts (2x). See image below.
NOTE: Tight both brackets. Re-adjust later if necessary.

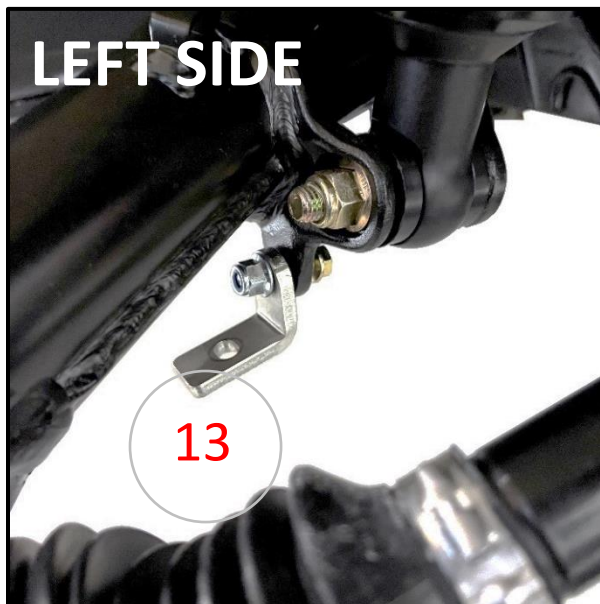

7. Install the clamps (12) to the new aluminum A-arm guards. Use the M6x16mm bolts (4x) with M6 cup washers (4x) and M6 lock nuts (4x). Refer to the image below. Do NOT tight now.

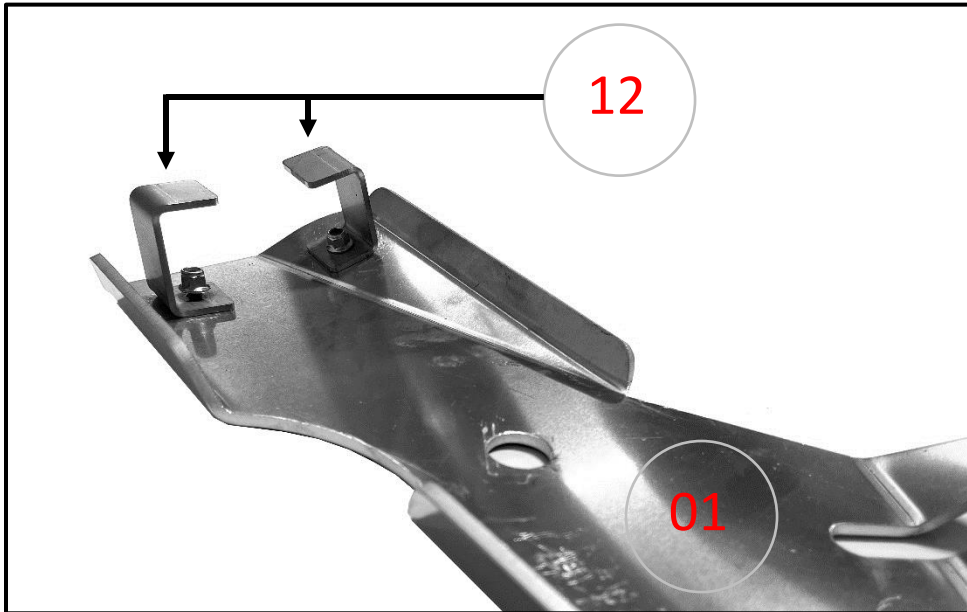

8. Install the new guards to the suspension arms. Use the M6x20mm carriage bolts (4x) with M6 lock nuts (4x) to secure the bottom of the guards to the clamps (14).
9. Secure the guards to the clamps (13) using the remaining M6x20mm bolts (2x), M6 cup washers (2x) and M6 lock nuts (2x).
10. Tight all the hardware once the guards are correctly installed & adjusted.
- Use a 10mm wrench and socket for the M6 hardware.
 - Use a 17mm wrench and socket for the M10 hardware.
- NOTE:** Start to tight hardware that are bolted to the clamps (13) and (14).
11. Put the wheels back on the ATV. Torque all lugs to factory specification.
- NOTE:** Check that the a-arm guards will clear the others components of the ATV. Re-adjust the guards if it's necessary.

