



INSTALLATION INSTRUCTIONS

SKU: **SP-A060F**

FRONT A-ARM GUARDS YAMAHA GRIZZLY 700 (2014+)

01

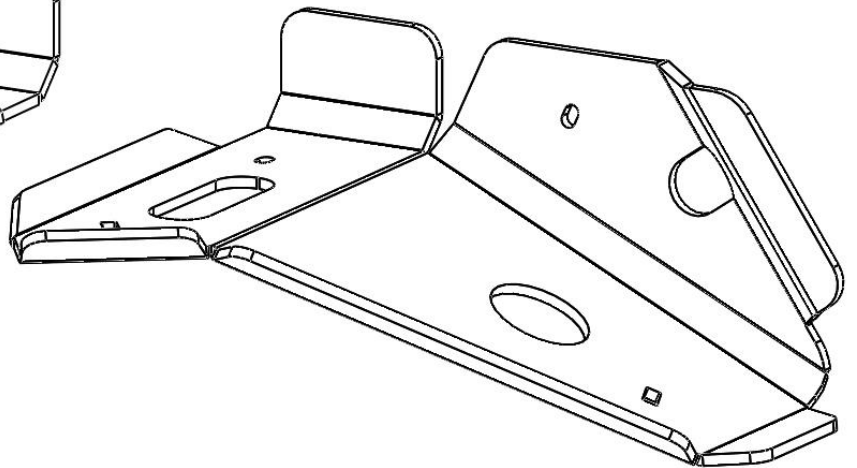
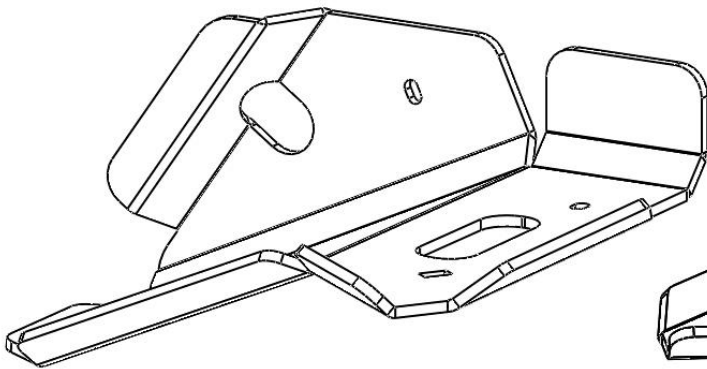

02

SAFETY WARNING

Please **read and understand** all instructions and safety warning prior to install the product. Failure to do so could result in product damage, personal injury or even death.

- Stay alert! Watch what you are doing and use common sense while handling this product.
- Inspect product for damage prior to installation, do not use if product is in unsafe condition.
- Do not install product while under the influence of drugs, alcohol or medication.
- Always use safety equipment to prevent injuries. Approved face and eye protection must always be worn by the installer, as well as others in the work area.
- Do not over reach. Keep proper footing and balance at all times.
- Dress properly. Do not wear loose clothing or jewelry. Keep your hair, clothing and gloves away from moving parts.
- Keep your work area clean and well lit.

Item	Part No.	Description	Qty.
COMPONENTS			
Those items are shown on the first page.			
01	A060-01	Front Left Aluminum A-arm Guard	1
02	A060-02	Front Right Aluminum A-arm Guard	1
HARDWARE			
Those items are included with each kit to install components.			
03	A-1505	M6-1.00 Flange Lock Nut	4
04	A-2605	M6-1.00 x 20mm Hex Flange Bolt	4
05	A-2662	M6-1.00 x 25mm Carriage Bolt	4
06	A-4001	Rubber Strip / Adhesive Back, 1x2" x 1/8" Thick	6
07	A-4013	7/8" Rubber Clamp / 0.281-hole dia.	2
08	A-4028	1-1/4" Steel Clamp / M6-1.00 Nut	2
09	B-5203	12mm ID. x 11/16" OD. x 3/16" Lg. Bushing	2
10	B-5606	Mounting Clamp	2

INSTALLATION INSTRUCTIONS

PREPARATION

- Using a jack under center of front end, lift until the front wheels leave the ground.
- Remove the wheels.
- Remove both factory A-arm guards.
- As shown below, stick the rubber strip on the new PERFEX A-arm guards.
- Install the rubber clamps on the suspension arms (see image below).

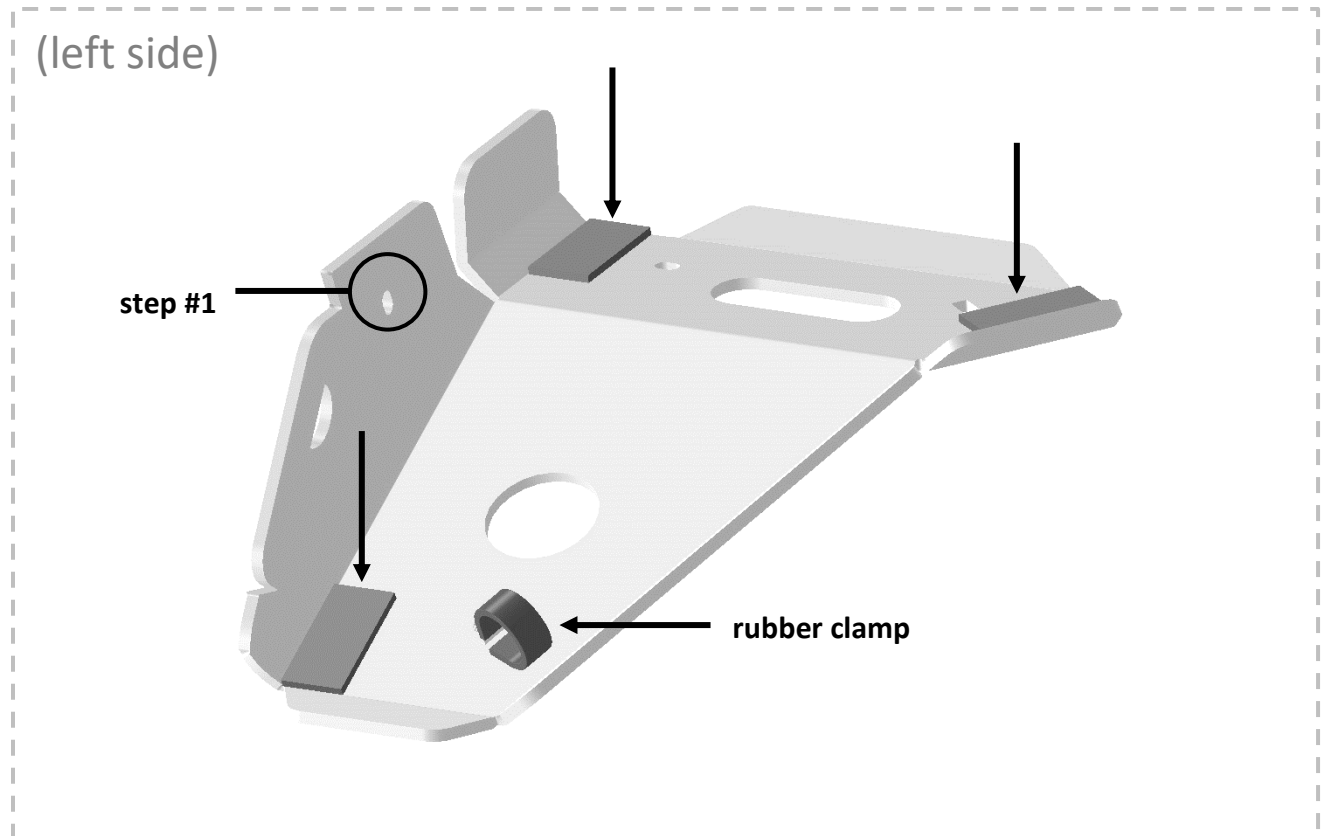

INSTALLATION

1. Install the guards to the suspension arms, using the factory mounting points (where the factory guards were connected). Use M6 hex bolts and 3/16" spacers to secure the guards to the arms.
NOTE: Put the spacers between the guards and the arms.
2. Secure the inside portion of the guards using the provided steel brackets.
NOTE: Use the bigger brackets for the front with M6 hex bolts.
NOTE 2: Use the smaller brackets on the back with M6 carriage bolts and M6 lock nuts.
3. Fix the bottom of the guards to the rubber clamps using M6 carriage bolts and M6 lock nuts.
4. Tight all the hardware once the guards are correctly installed.
5. Put the wheels back on the ATV. Torque all lugs to factory specification.
NOTE: Check that the a-arm guards will clear the others components of the ATV. Re-adjust the guards if it's necessary.



INSTALLATION INSTRUCTIONS

SKU: **SP-A060R**

REAR A-ARM GUARDS YAMAHA GRIZZLY 700 (2014+)

01

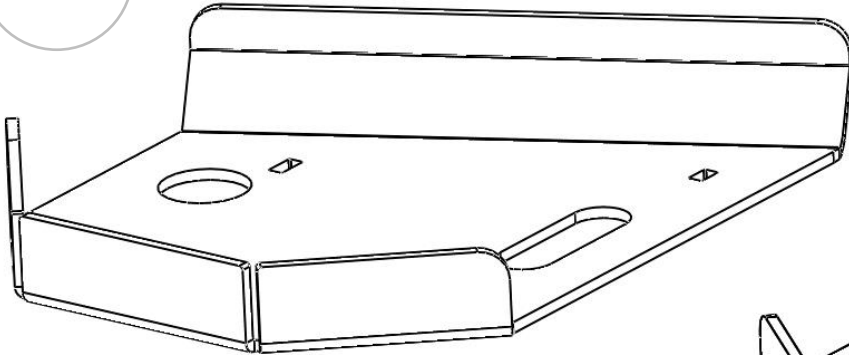

02

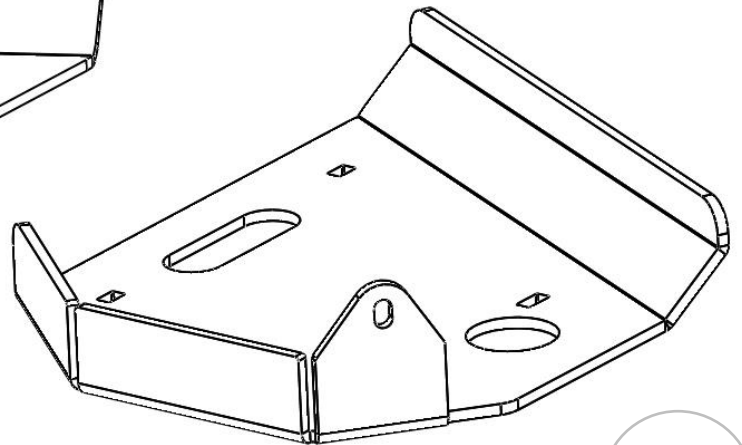

SAFETY WARNING

Please **read and understand** all instructions and safety warning prior to install the product. Failure to do so could result in product damage, personal injury or even death.

- Stay alert! Watch what you are doing and use common sense while handling this product.
- Inspect product for damage prior to installation, do not use if product is in unsafe condition.
- Do not install product while under the influence of drugs, alcohol or medication.
- Always use safety equipment to prevent injuries. Approved face and eye protection must always be worn by the installer, as well as others in the work area.
- Do not over reach. Keep proper footing and balance at all times.
- Dress properly. Do not wear loose clothing or jewelry. Keep your hair, clothing and gloves away from moving parts.
- Keep your work area clean and well lit.

Item	Part No.	Description	Qty.
COMPONENTS			
Those items are shown on the first page.			
01	A060-03	Rear Left Aluminum A-arm Guard	1
02	A060-04	Rear Right Aluminum A-arm Guard	1
HARDWARE			
Those items are included with each kit to install components.			
03	A-1505	M6-1.00 Flange Lock Nut	6
04	A-2605	M6-1.00 x 20mm Hex Flange Bolt	2
05	A-2662	M6-1.00 x 25mm Carriage Bolt	4
06	A-2682	M6-1.00 x 50mm Carriage Bolt	2
07	A-4001	Rubber Strip / Adhesive Back, 1x2" x 1/8" Thick	4
08	A-4014	1" Rubber Clamp / 0.281-hole dia.	4

INSTALLATION INSTRUCTIONS

PREPARATION

- Using a jack under center of rear end, lift until the rear wheels leave the ground.
- Remove the wheels.
- Remove both factory A-arm guards.
- As shown below, stick the rubber strip on the new PERFEX A-arm guards.
- Install the rubber clamps on the suspension arms (see image below).

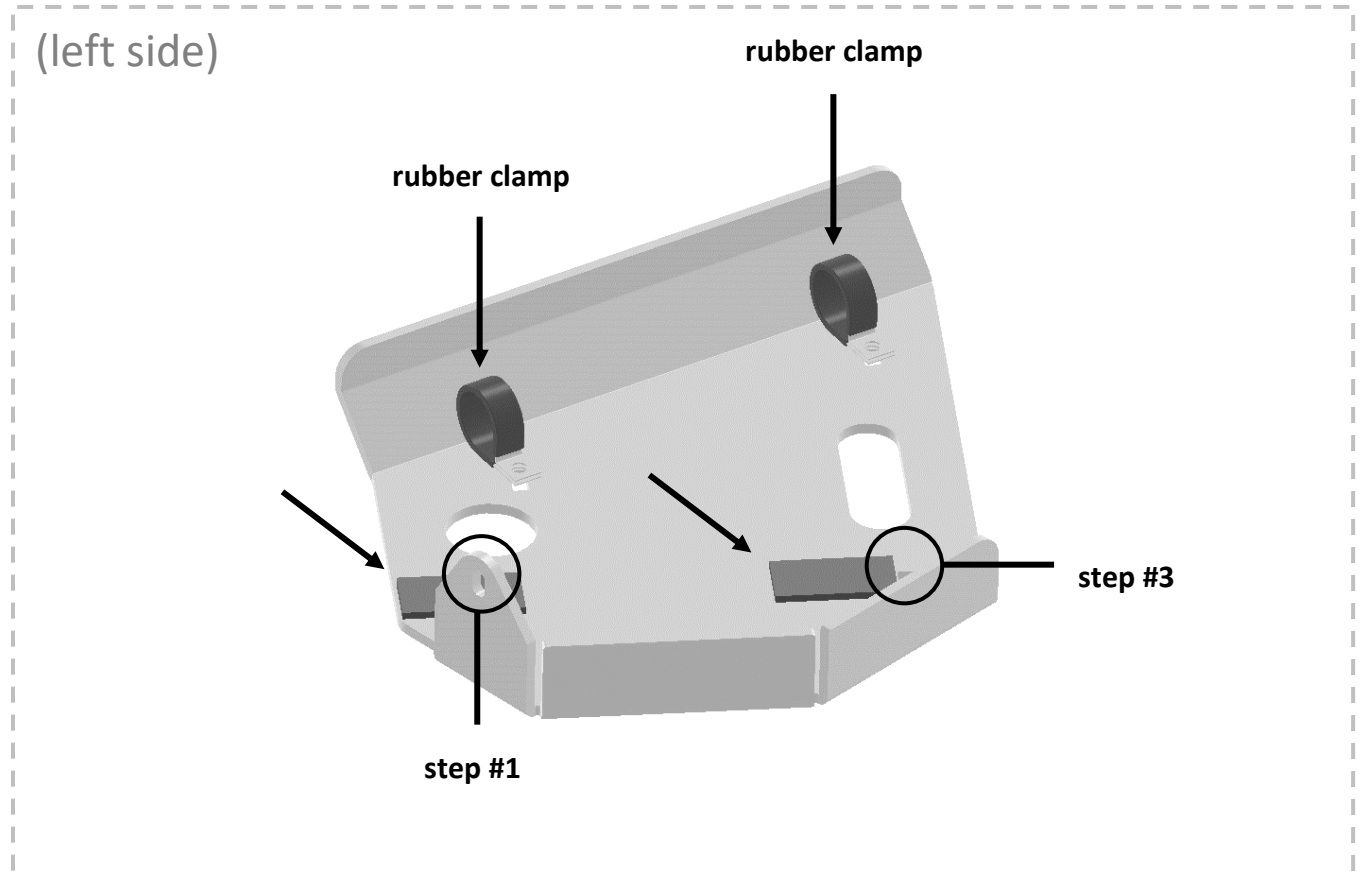

INSTALLATION

6. Install the guards to the suspension arms, using the factory mounting points (where the factory guards were connected on the back). Use M6 hex bolts to secure the guards to the arms.
7. Fix the front of the guards to the rubber clamps using M6x25mm carriage bolts and M6 lock nuts.
8. Secure the guards to the arms using the remaining M6x50mm carriage bolts and M6 lock nuts.
9. Tight all the hardware once the guards are correctly installed.

10. Put the wheels back on the ATV. Torque all lugs to factory specification.

NOTE: Check that the a-arm guards will clear the others components of the ATV. Re-adjust the guards if it's necessary.