

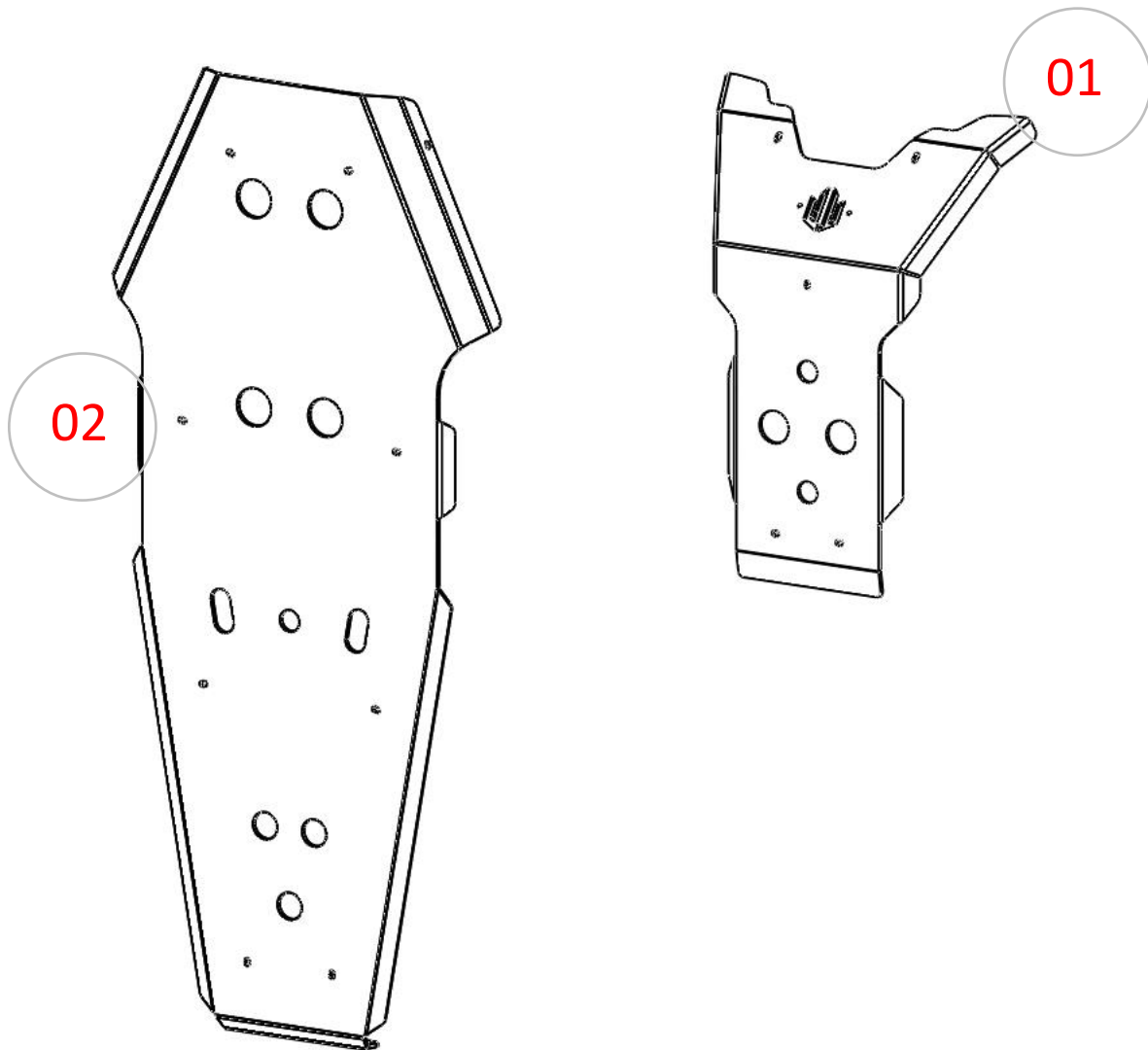

INSTALLATION INSTRUCTIONS

SKU: **SP-3161**

CENTRAL PLATES YAMAHA GRIZZLY 550/700 (2007-15)



SAFETY WARNING

Please **read and understand** all instructions and safety warning prior to install the product. Failure to do so could result in product damage, personal injury or even death.

- Stay alert! Watch what you are doing and use common sense while handling this product.
- Inspect product for damage prior to installation, do not use if product is in unsafe condition.
- Do not install product while under the influence of drugs, alcohol or medication.
- Always use safety equipment to prevent injuries. Approved face and eye protection must always be worn by the installer, as well as others in the work area.
- Do not over reach. Keep proper footing and balance at all times.
- Dress properly. Do not wear loose clothing or jewelry. Keep your hair, clothing and gloves away from moving parts.
- Keep your work area clean and well lit.

Item	Part No.	Description	Qty.
COMPONENTS			
Those items are shown on the first page.			
01	3161-01	Front Aluminum Central Plate	1
02	3161-02	Rear Aluminum Central Plate	1
HARDWARE (3161-01)			
Those items are included with each kit to install the front plate.			
03	A-1101	1/4" x 1.250" OD. Flat Fender Washer	1
04	A-1505	M6-1.00 Flange Lock Nut	1
05	A-2605	M6-1.00 x 20mm Hex Flange Bolt	4
06	A-2613	M6-1.00 x 40mm Hex Flange Bolt	1
07	A-4001	Rubber Strip / Adhesive Back, 1x2" x 1/8" Thick	4
08	A-4028	1-1/4" Steel Clamp / M6-1.00 Nut	2
HARDWARE (3161-02)			
Those items are included with each kit to install the rear plate.			
05	A-2605	M6-1.00 x 20mm Hex Flange Bolt	10
07	A-4001	Rubber Strip / Adhesive Back, 1x2" x 1/8" Thick	8
08	A-4028	1-1/4" Steel Clamp / M6-1.00 Nut	6
09	B-5204	12mm ID. x 11/16" OD. x 1/4" Lg. Bushing	2

INSTALLATION INSTRUCTIONS

PREPARATION

- We recommend to standing the ATV up on its end, to be able to install easily the plate under the bike.
- Remove the factory skid plates.
- On the new skid plates, stick the provided rubber strips. **Refer to the image below.**

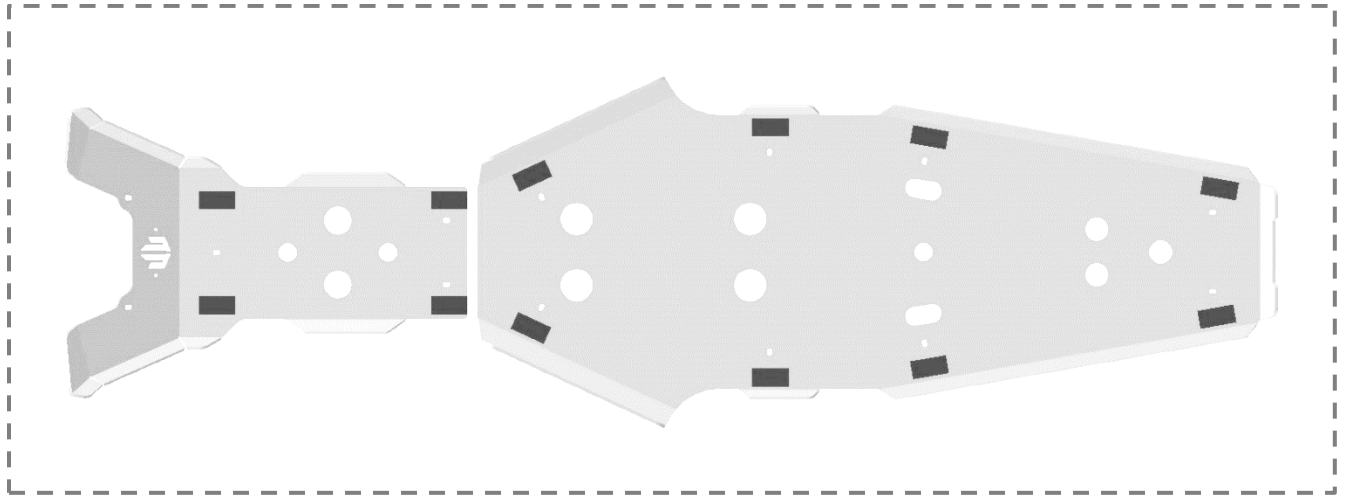

INSTALLATION (do not tight until all was fixed correctly)

1. Start with the bottom of the rear skid plate. Fix it to the factory mounting points (**where the bottom of the rear plastic skid plate was bolted**). Use (2x) M6-1.00 x 20mm hex flange bolt and (2x) 1/4" Lg. spacer. **See image below.**

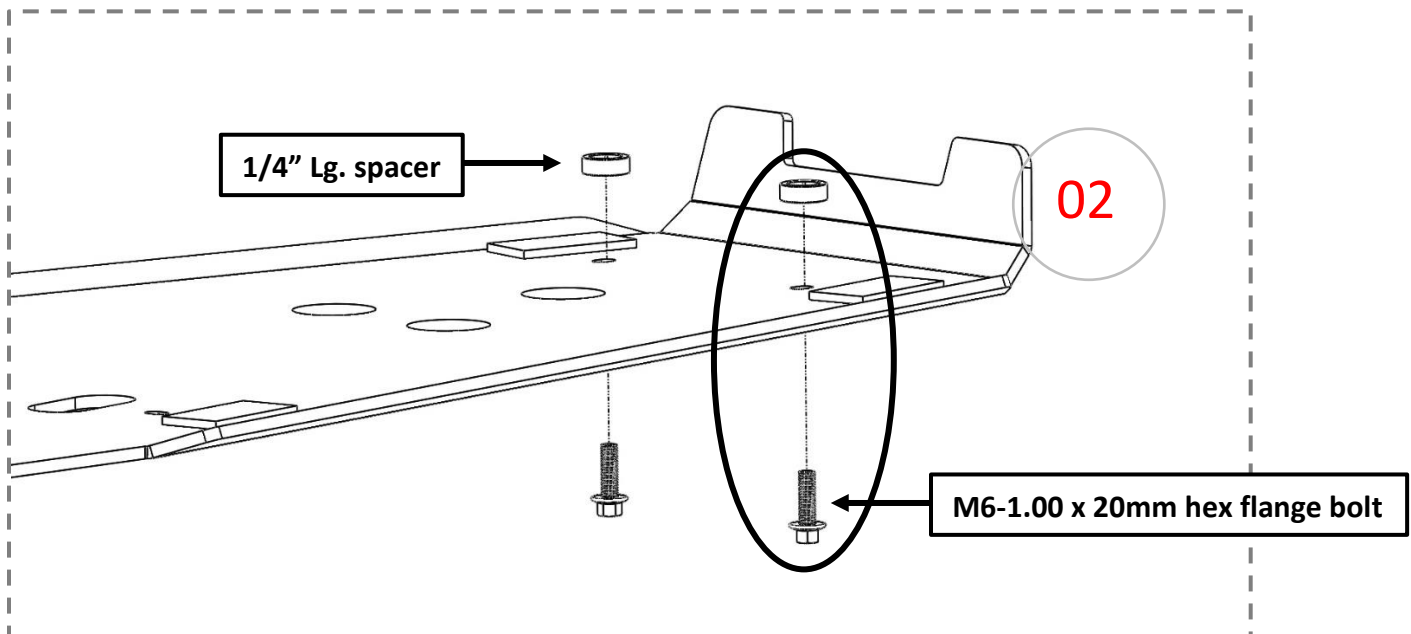

2. Using the provided (6x) 1-1/4" clamp and (6x) M6-1.00 x 20mm hex flange bolt, secure the underside of the rear plate to the frame. See image below.

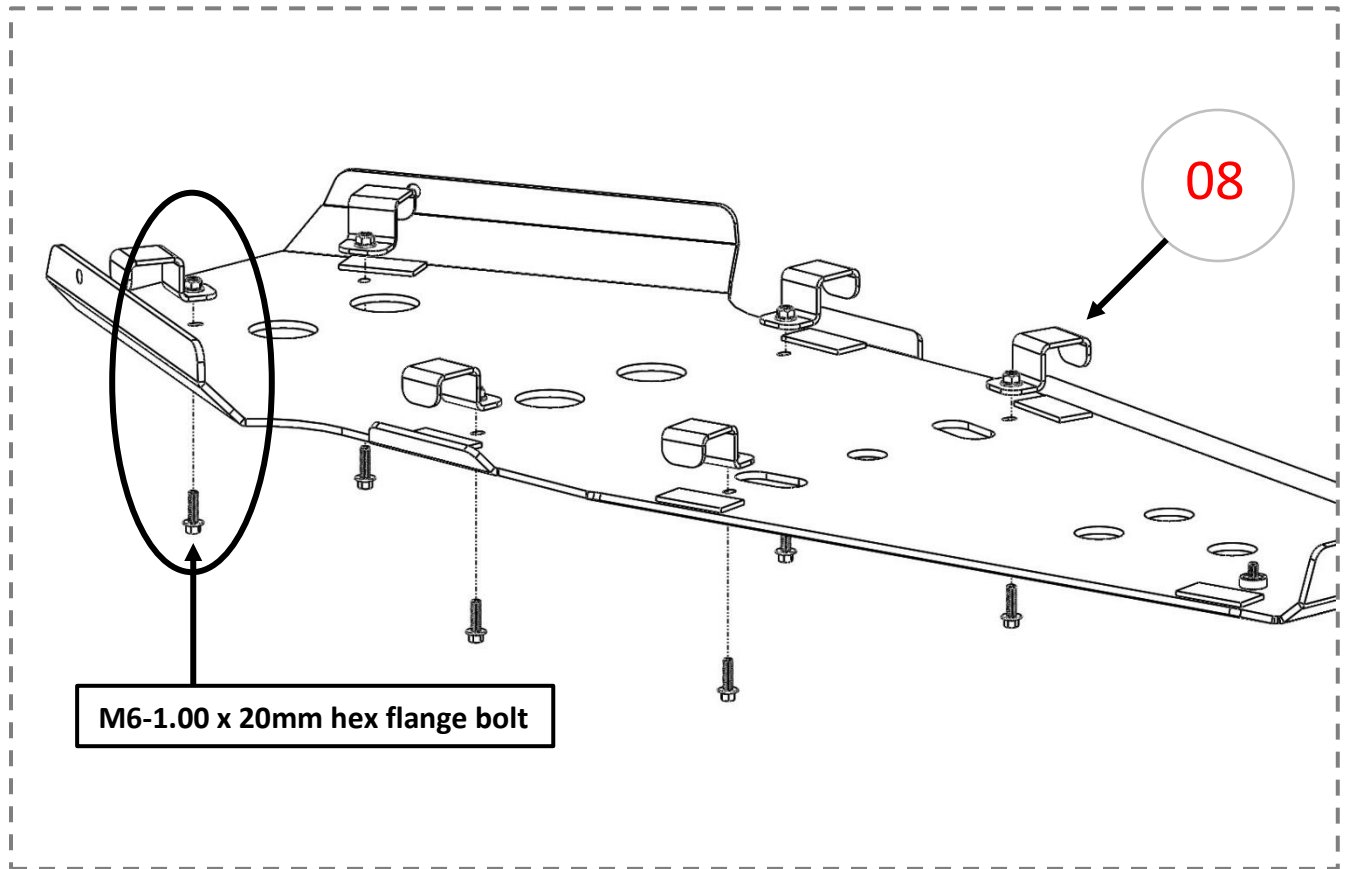

3. Install the front skid plate to the frame. Use (2x) 1-1/4" clamp and (2x) M6-1.00 x 20mm hex flange bolt. See image below.

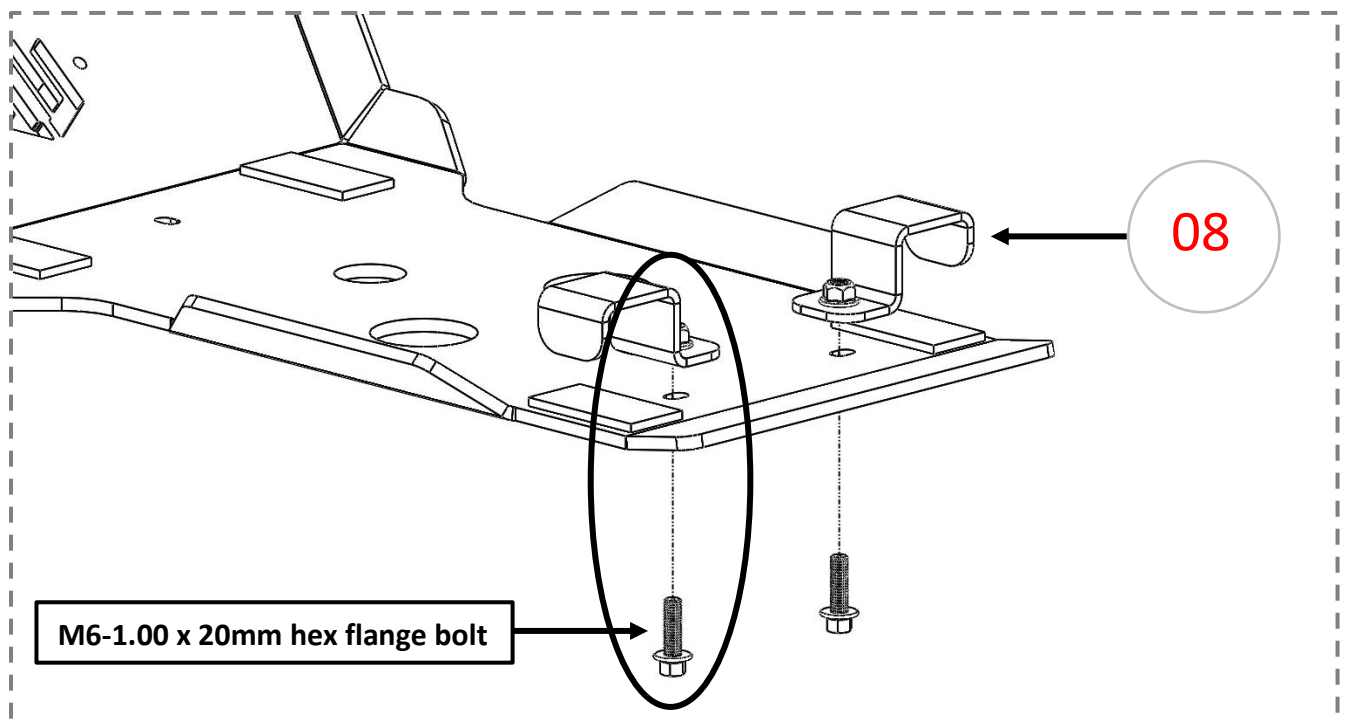

4. Then, use (1x) M6-1.00 x 40mm hex flange bolt, (1x) 1/4" fender washer and (1x) M6-1.00 lock nut. Put the washer and the lock nut above the frame. **See image below.**

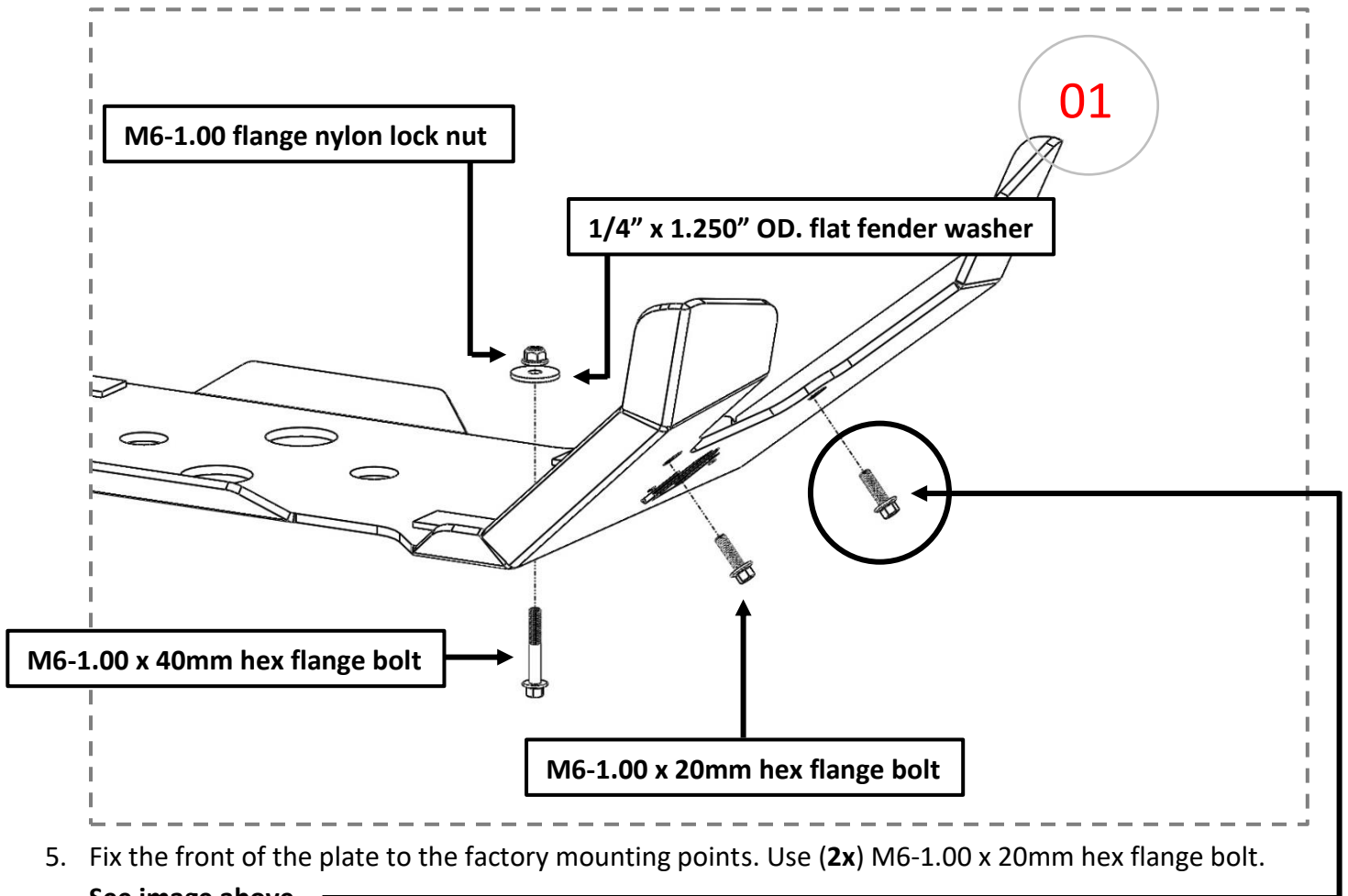

5. Fix the front of the plate to the factory mounting points. Use (2x) M6-1.00 x 20mm hex flange bolt. **See image above.**
6. Last step, using the remaining (2x) M6-1.00 x 20mm hex flange bolt, secure both sides of the rear skid plate to the plastics, as shown below.

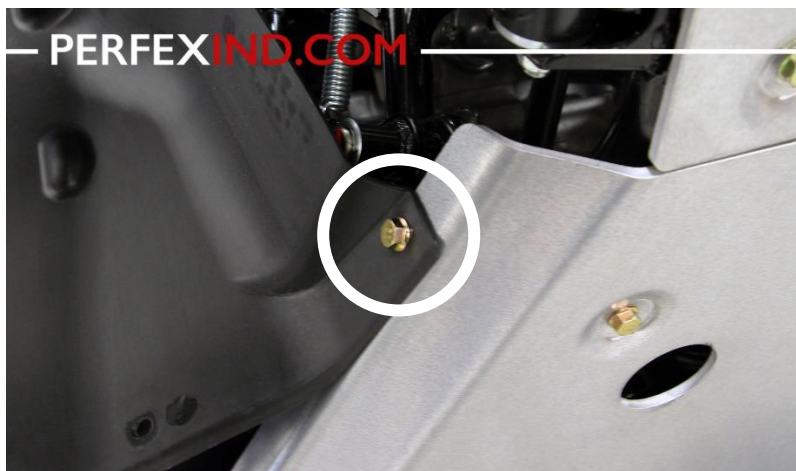

7. Once both skid plates are correctly installed, tight all the bolts appropriately. **Note:** Do not over tight bolts that are bolted to the factory mounting points. Those threads can break easily.