

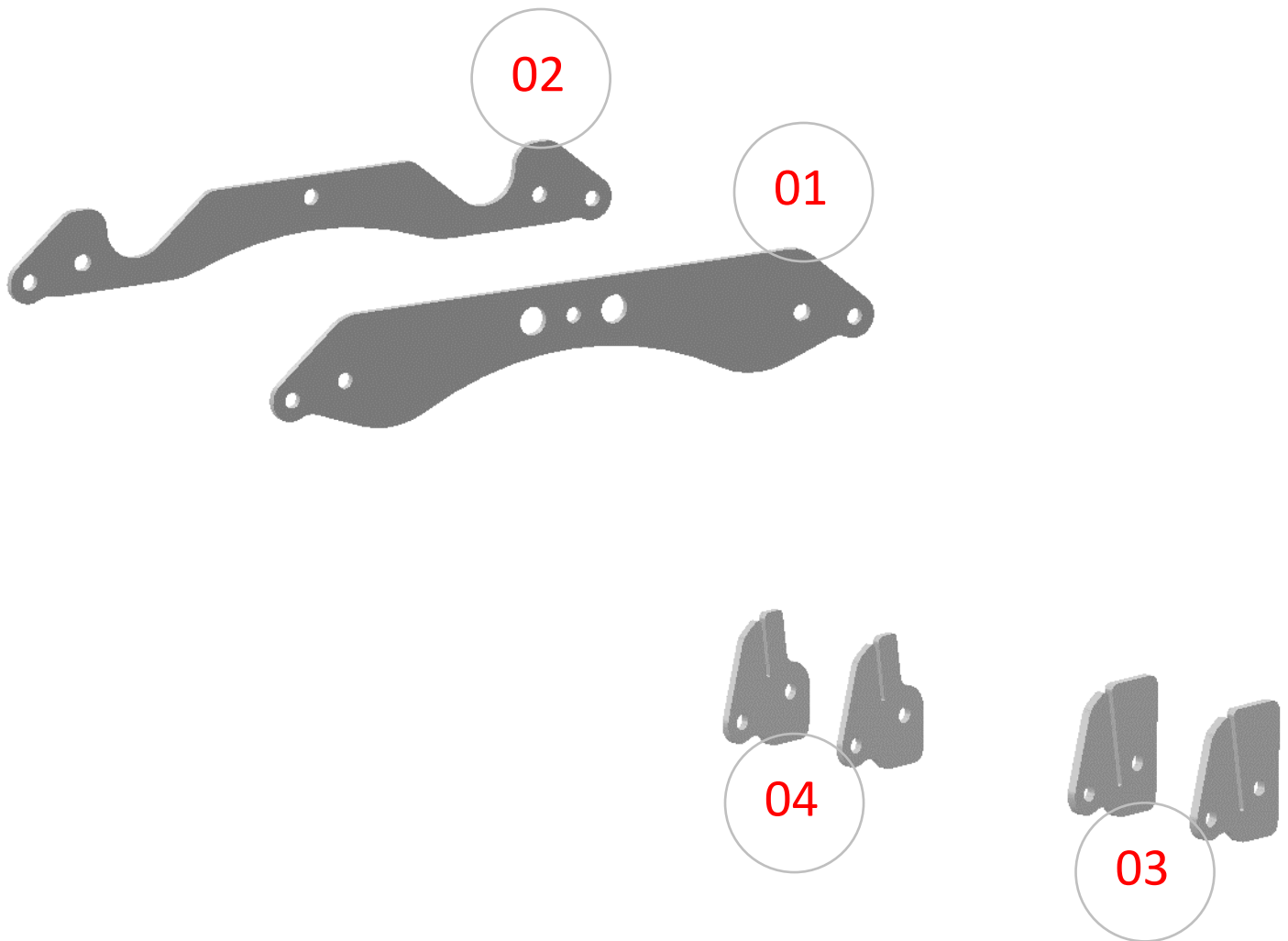

INSTALLATION INSTRUCTIONS

SKU: **LK-10310**

2" LIFT KIT POLARIS RZR 900 TRAIL (2021+)



Item	Part No.	Description	Torque	Qty.
------	----------	-------------	--------	------

LIFT COMPONENTS

Those items are shown on the first page.

01	310-01	Front Lift Bracket		1
02	310-02	Front Lift Bracket		1
03	310-03	Rear Lift Bracket		2
04	310-04	Rear Lift Bracket		2

FRONT HARDWARE

Those items are included with each kit to install the front lift components.

05	A-1008	M10 Flat Washer		3
06	A-1105	3/8" x 1.250" OD. Flat Fender Washer		1
07	A-1509	M10-1.50 Flange Lock Nut	36 to 38 ft-lbs	3
08	A-3021	M10-1.50 x 60mm Hex Flange Bolt	36 to 38 ft-lbs	3
09	B-5216	12mm ID. x 11/16" OD. x 1" Lg. Spacer		3

REAR HARDWARE

Those items are included with each kit to install the rear lift components.

10	A-1058	M10 Flat Heavy Washer		2
07	A-1509	M10-1.50 Flange Lock Nut	36 to 38 ft-lbs	4
11	A-3023	M10-1.50 x 65mm Hex Flange Bolt	36 to 38 ft-lbs	4
12	B-5004	10mm ID. x 5/8" OD. x 1/4" Lg. Spacer		2
13	B-5219	12mm ID. x 11/16" OD. x 1-3/16" Lg. Spacer		2

Good to know:

For the Razor with fox shocks, we recommend you to adjust the preload of the front shocks at 4-3/4 inches. And the preload of the rear shocks at 1-3/8 inches.

Always consult your owner's manual for the factory settings for your specific year and model. PERFEX has found the 1-3/8" and 4-3/4" to be a good starting point.

On the rear installation, disconnecting the sway bar will help for the installation of the lift bracket. Reconnect once the job is done.

PLEASE READ AND UNDERSTAND BEFORE THE INSTALLATION

CUSTOMER AND/OR END USER:

This product is designed for use on ATVs and/or UTVs to increase ground clearance and fender clearance. Purchasers should be aware that use of this product may increase the frequency of required maintenance, part wear...

Using a lift kit will raise the center of gravity on your ATV and/or UTV, increasing risk of roll-over, injury and death on ALL types of terrain. It's YOUR RESPONSIBILITY to always inform other operators and passengers of this vehicle about the added risks.

Our products are designed to best fit user's ATV/UTV under stock conditions. Adding, modifying, or fabricating any OEM or aftermarket parts will void warranty. PERFEX Industries products could interfere with other aftermarket accessories. If the user has aftermarket products on machine, please contact PERFEX Industries to verify that they will work together.

Adding aftermarket suspension components and/or more aggressive tires can cause breakage of other OEM driveline components such as differentials, axles or drive shafts.

We ALWAYS recommend that wider tires and/or wheel spacers be used to achieve a wider stance and to improve stability of the ATV and/or UTV. Riders should be advised that the handling characteristics of a taller ATV and/or UTV are different and require extra care when riding, particularly on side hills or off-camber situations. If you further raise the center of gravity by adding taller tires, heavy loads to racks or seats, or by any other means, the ATV and/or UTV must be operated with even more care, at slower speeds and on relatively flat ground. All turns should be done at a slow speed, even on level ground.

Operation of an ATV and/or UTV with or without modified suspension components, while or shortly after consuming alcohol or drugs, subjects the rider to the risk of serious bodily harm or possible death. This risk is compounded if the rider does not wear an approved helmet and other safety gear.

PERFEX Industries urges that all approved safety gear be worn when riding an ATV and/or UTV as a driver or passenger.

By purchasing and installing PERFEX Industries products, user agrees that should damages occur, PERFEX Industries will not be held responsible for loss of time, use, labor fees, replacement parts, or freight charges. WE (PERFEX Industries) will not be held responsible for any direct, indirect, incidental, special, or consequential damages that result from any product purchased from PERFEX Industries.

PLEASE TAKE NOTE: The total liability of seller to user for all damages, losses, and causes of action, will never exceed the total purchase price paid for the product that gives rise to the claim.

DEALER AND/OR OTHER INSTALLERS:

You are responsible for informing your customer and end user of the information contained above and the increased potential hazards of operating an ATV and/or UTV equipped with modified suspension components.

If you install any suspension modifying components, it is your responsibility to also install a warning label prominently in view of the driver and in prominent view of the driver and passenger on UTVs and multi-passenger ATVs.

They should also be instructed to notify anyone operating the vehicle, as well as any passengers, that said vehicle is modified.

As discussed above, it is critically important that they be instructed in the need for slower speed operation, regardless of terrain, after this lift kit is installed.

FRONT INSTALLATION INSTRUCTIONS

PREPARATION

- Using a jack under center of front end, lift until the front wheels leave the ground.
- Remove the wheels.
- Disconnect the top of the front shock from the frame shock mount. Save factory hardware.
- Remove the hood.
- Remove the vent tube from the frame cross member.
- Remove the clips that attach the wires to the frame cross member.

INSTALLATION

1. Insert the front inner bracket (02) inside of the frame mounting. See image 1.
2. Install the bracket to the frame shock mount. Use M10-1.50 x 60mm bolts and 1" spacers. See image 1.
3. Insert one M10 washer at the end of each bolt. See image 1.

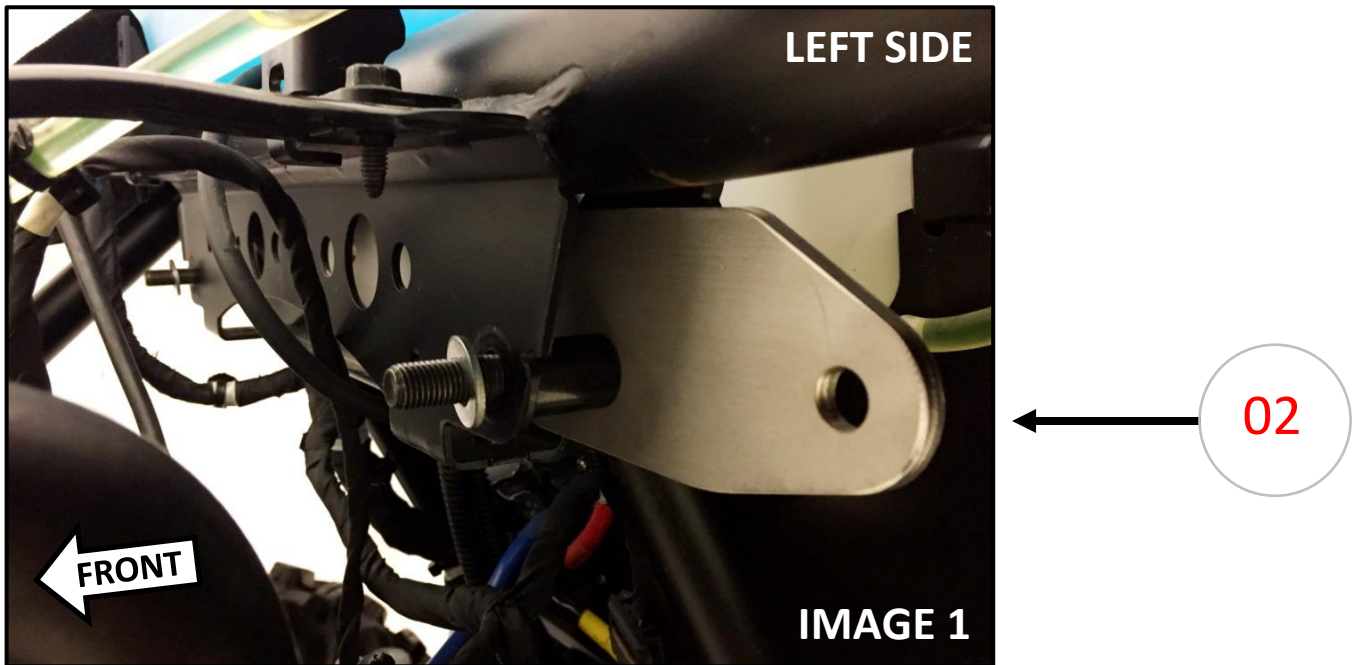

4. Insert the second bracket (01) to the assembly. Secure with M10-1.50 lock nuts at the end of each bolt. See image 2.

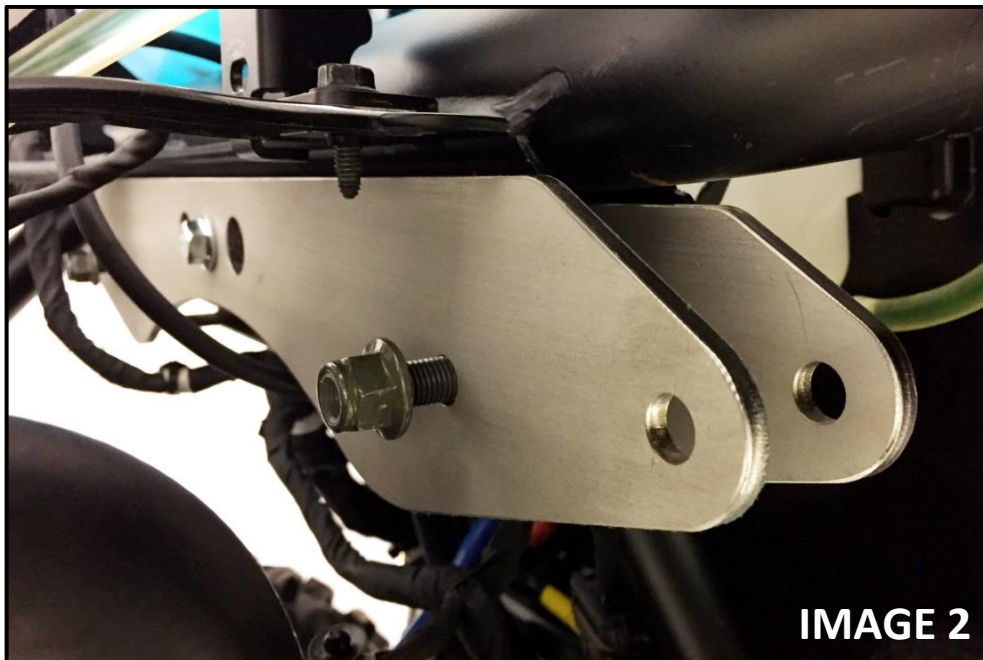

5. Secure the middle of the brackets together. Use M10-1.50 x 60mm bolt, M10 washer, 1" spacer, 3/8" fender washer and M10-1.50 lock nut.
 - Put the M10 washer between the front outer bracket and the frame mounting.
 - Put the spacer between the frame mounting.
 - Put the 3/8" fender washer at the end with the M10-1.50 lock nut.
6. Connect the top of the shocks to the brackets. Use factory hardware.
7. Tight all the hardware appropriately at this point.
8. Put the vent tube back through the frame cross member.
9. Put the wheels back on the UTV when the installation is finished. Torque all lugs to factory specification.

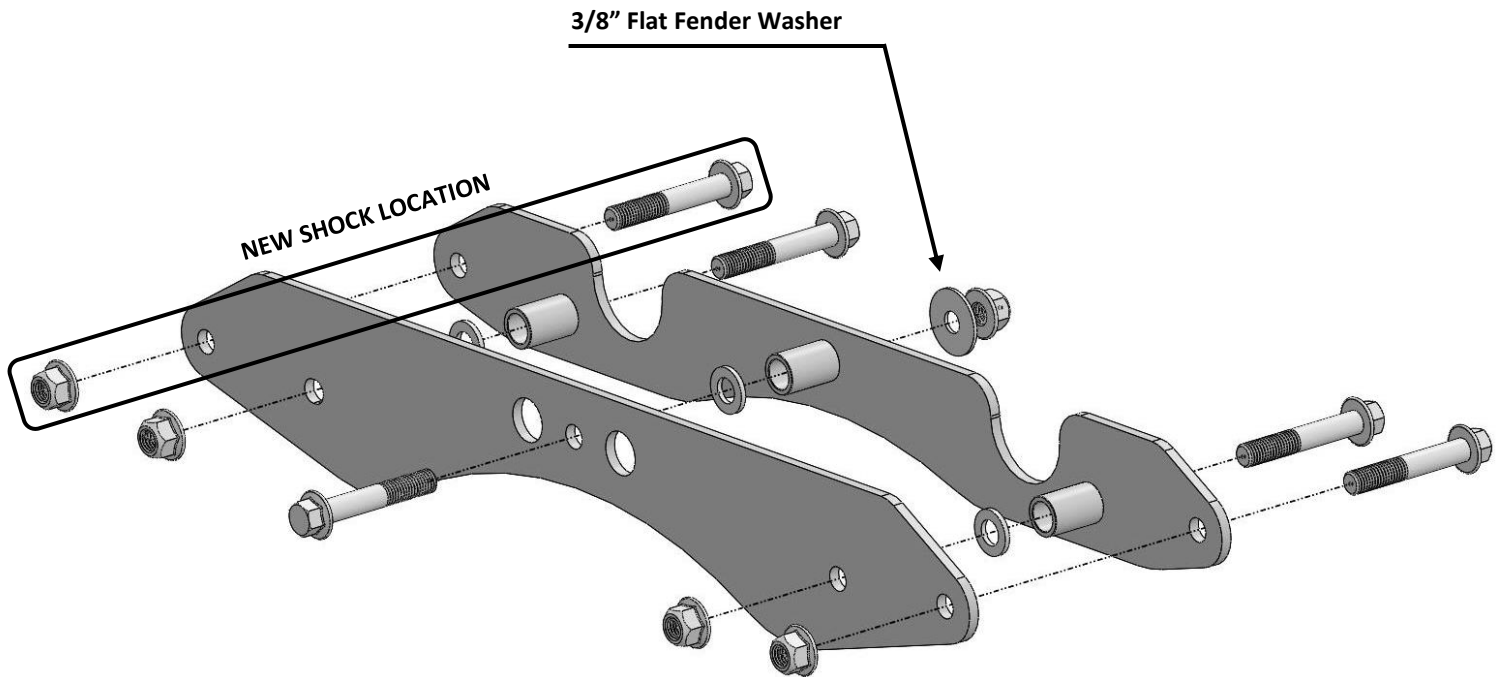

REAR INSTALLATION INSTRUCTIONS

PREPARATION

- Using a jack under center of rear end, lift until the rear wheels leave the ground.
- Remove the wheels.
- Disconnect the top of the shocks from the frame shock mount.

INSTALLATION

1. Install the rear brackets (one **03** and one **04** on each side) to the frame shock mount. Use M10-1.50 x 65mm bolt, 1-3/16" spacer and M10-1.50 lock nut. See images below.
2. Connect the top of the shock to the brackets. Use M10-1.50 x 65mm bolt, heavy washer, 1/4" spacer and M10-1.50 lock nut.
 - Put the heavy washer between the bracket (**03**) and the shock eyelet. See image below.
 - Put the 1/4" spacer between the bracket (**04**) and the shock eyelet. See image below.

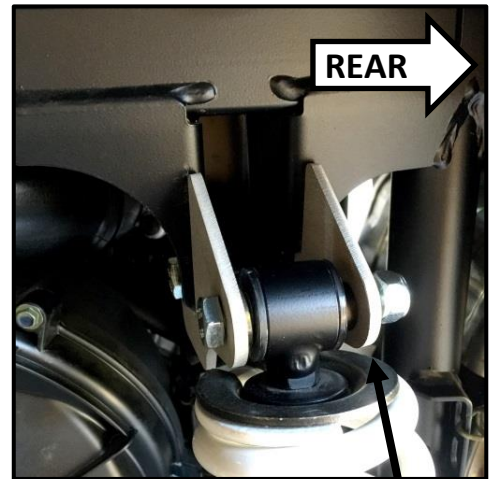

3. Tight all the hardware appropriately at this point.
4. Repeat the same steps for the opposite side.
5. Using the OEM shock spanner wrench, tight the preload adjustment of one position higher.
6. Put the wheels back on the UTV when the installation is finished. Torque all lugs to factory specification.

