

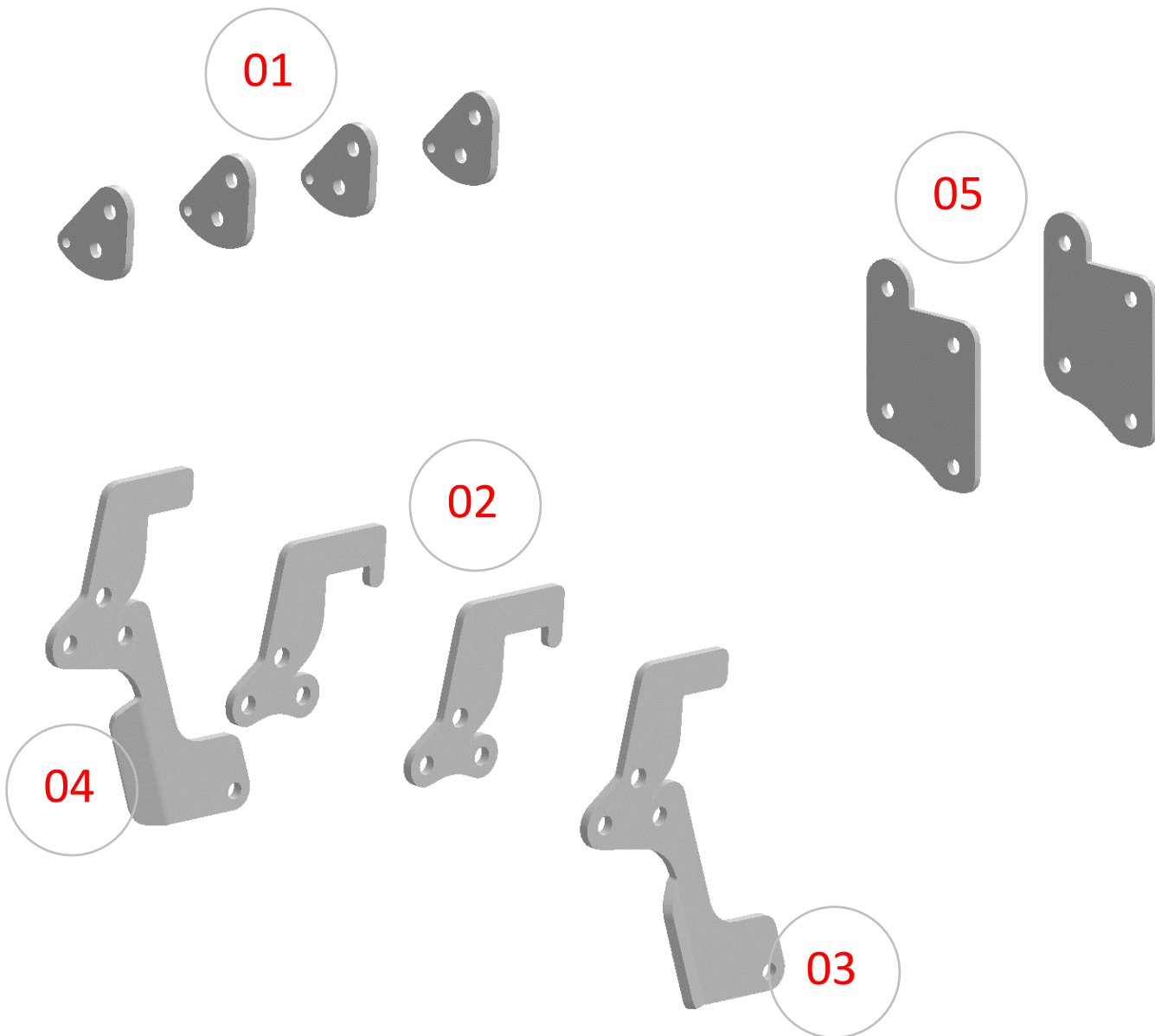

INSTALLATION INSTRUCTIONS

SKU: **LK-10282**

2" LIFT KIT YAMAHA WOLVERINE 850 (2018+)



Item	Part No.	Description	Torque	Qty.
LIFT COMPONENTS				
Those items are shown on the first page.				
01	282-01	Front Lift Bracket		4
02	282-02	Rear Lift Bracket		2
03	282-03L	Rear Lift Bracket (left side)		1
04	282-03R	Rear Lift Bracket (right side)		1
05	283-06	Rear Sway Bar Relocation Bracket		2

FRONT HARDWARE				
Those items are included with each kit to install the front lift components.				
06	A-1058	M10 Flat Heavy Washer		4
07	A-1505	M6-1.00 Flange Lock Nut	7.8 ft-lbs	2
08	A-1509	M10-1.50 Flange Lock Nut	36 to 38 ft-lbs	4
09	A-2621	M6-1.00 x 60mm Hex Flange Bolt	7.8 ft-lbs	2
10	A-3023	M10-1.50 x 65mm Hex Flange Bolt	36 to 38 ft-lbs	4
11	B-5220	12mm ID. x 11/16" OD. x 1-1/4" Lg. Spacer		2

REAR HARDWARE				
Those items are included with each kit to install the rear lift components.				
12	A-1008	M10 Flat Washer		6
13	A-1010	M12 Flat Washer		8
14	A-1058	M10 Flat Heavy Washer		10
08	A-1509	M10-1.50 Flange Lock Nut	36 to 38 ft-lbs	6
15	A-1510	M12-1.75 Lock Nut	62 to 64 ft-lbs	4
16	A-3006	M10-1.50 x 25mm Hex Bolt	36 to 38 ft-lbs	6
17	A-3030	M10-1.50 x 90mm Hex Bolt	36 to 38 ft-lbs	2
18	A-3234	M12-1.75 x 110mm Hex Bolt	62 to 64 ft-lbs	4
19	B-5207	12mm ID. x 11/16" OD. x 7/16" Lg. Spacer		2
20	B-5214	12mm ID. x 11/16" OD. x 7/8" Lg. Spacer		2
21	B-5216	12mm ID. x 11/16" OD. x 1" Lg. Spacer		4
22	B-5218	12mm ID. x 11/16" OD. x 1-1/8" Lg. Spacer		2
23	B-5225	12mm ID. x 11/16" OD. x 1-9/16" Lg. Spacer		2

PLEASE READ AND UNDERSTAND BEFORE THE INSTALLATION

CUSTOMER AND/OR END USER:

This product is designed for use on ATVs and/or UTVs to increase ground clearance and fender clearance. Purchasers should be aware that use of this product may increase the frequency of required maintenance, part wear...

Using a lift kit will raise the center of gravity on your ATV and/or UTV, increasing risk of roll-over, injury and death on ALL types of terrain. It's YOUR RESPONSIBILITY to always inform other operators and passengers of this vehicle about the added risks.

Our products are designed to best fit user's ATV/UTV under stock conditions. Adding, modifying, or fabricating any OEM or aftermarket parts will void warranty. PERFEX Industries products could interfere with other aftermarket accessories. If the user has aftermarket products on machine, please contact PERFEX Industries to verify that they will work together.

Adding aftermarket suspension components and/or more aggressive tires can cause breakage of other OEM driveline components such as differentials, axles or drive shafts.

We ALWAYS recommend that wider tires and/or wheel spacers be used to achieve a wider stance and to improve stability of the ATV and/or UTV. Riders should be advised that the handling characteristics of a taller ATV and/or UTV are different and require extra care when riding, particularly on side hills or off-camber situations. If you further raise the center of gravity by adding taller tires, heavy loads to racks or seats, or by any other means, the ATV and/or UTV must be operated with even more care, at slower speeds and on relatively flat ground. All turns should be done at a slow speed, even on level ground.

Operation of an ATV and/or UTV with or without modified suspension components, while or shortly after consuming alcohol or drugs, subjects the rider to the risk of serious bodily harm or possible death. This risk is compounded if the rider does not wear an approved helmet and other safety gear.

PERFEX Industries urges that all approved safety gear be worn when riding an ATV and/or UTV as a driver or passenger.

By purchasing and installing PERFEX Industries products, user agrees that should damages occur, PERFEX Industries will not be held responsible for loss of time, use, labor fees, replacement parts, or freight charges. WE (PERFEX Industries) will not be held responsible for any direct, indirect, incidental, special, or consequential damages that result from any product purchased from PERFEX Industries.

PLEASE TAKE NOTE: The total liability of seller to user for all damages, losses, and causes of action, will never exceed the total purchase price paid for the product that gives rise to the claim.

DEALER AND/OR OTHER INSTALLERS:

You are responsible for informing your customer and end user of the information contained above and the increased potential hazards of operating an ATV and/or UTV equipped with modified suspension components.

If you install any suspension modifying components, it is your responsibility to also install a warning label prominently in view of the driver and in prominent view of the driver and passenger on UTVs and multi-passenger ATVs.

They should also be instructed to notify anyone operating the vehicle, as well as any passengers, that said vehicle is modified.

As discussed above, it is critically important that they be instructed in the need for slower speed operation, regardless of terrain, after this lift kit is installed.

FRONT INSTALLATION INSTRUCTIONS

PREPARATION

- Using a jack under center of front end, lift until the front wheels leave the ground.
- Disconnect the bottom of the shocks from the suspension arms. Use a 14mm and a 17mm wrench and socket.



DISCONNECT

INSTALLATION

1. Install (1x) front bracket to the shock mount. Use (1x) M10-1.50 x 65mm bolt and (1x) 1-1/4" Lg. spacer.

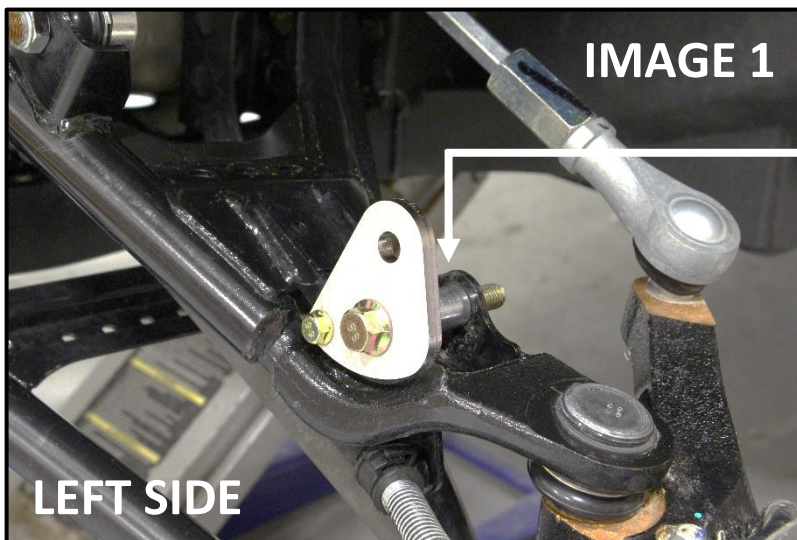

SPACER

LEFT SIDE

2. Secure the brackets to the shock mount using (1x) M6-1.00 x 60mm bolt. See IMAGE 1.
3. Connect the bottom of the shock to the bracket. Use (1x) M10-1.50 x 65mm bolt and (2x) M10 heavy washer.



4. Insert another front bracket at the end of the bolts. Secure using the appropriated lock nut.



5. Tight all the hardware appropriately at this point.
- Use a 10mm wrench and socket for the M6 hardware.
 - Use a 14mm and a 15mm wrench and socket for the M10 hardware.
6. Repeat the same steps for the opposite side.

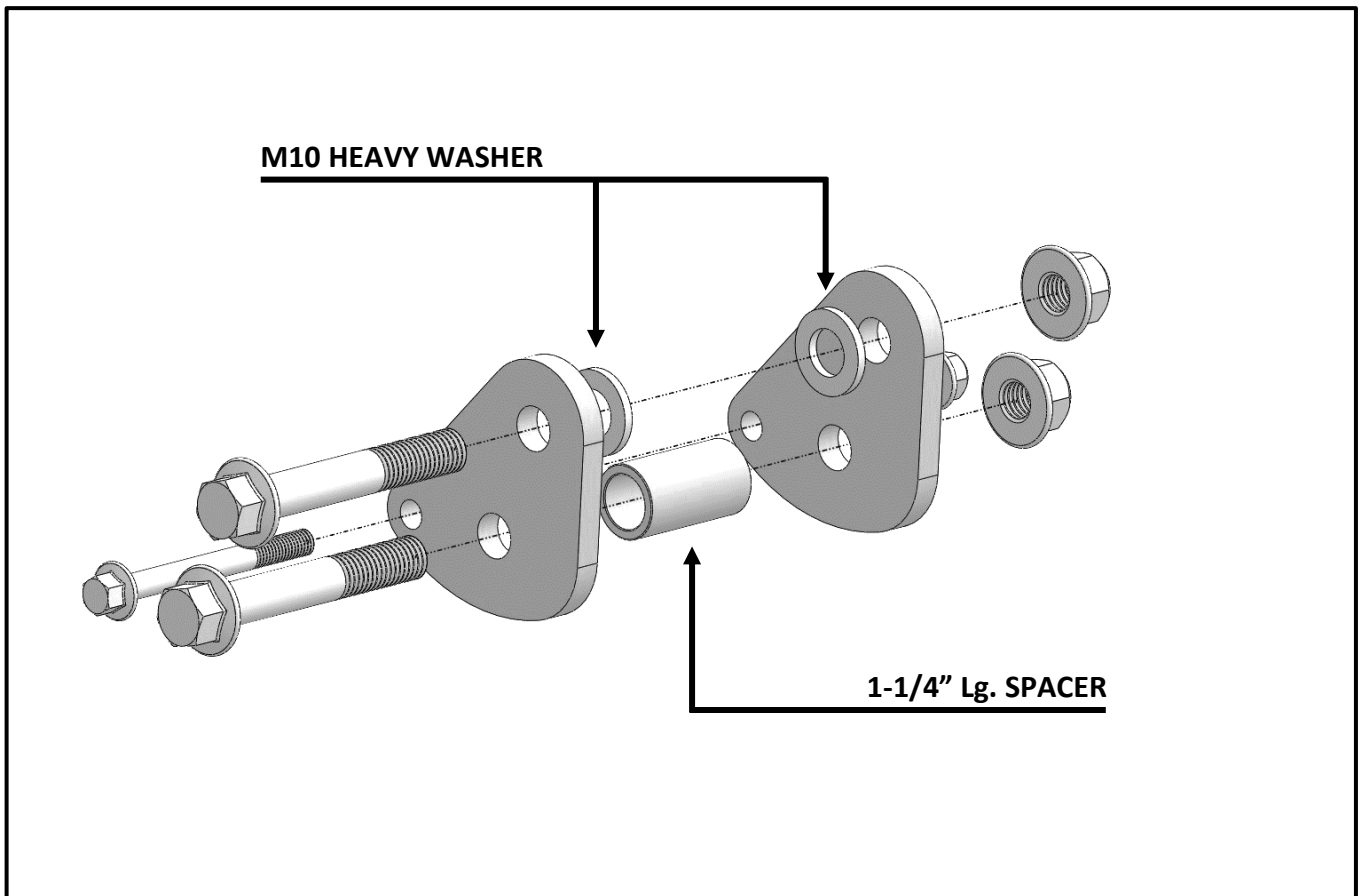

REAR INSTALLATION INSTRUCTIONS

PREPARATION

- Using a jack under center of rear end, lift until the rear wheels leave the ground.
- Remove the wheels.
- Disconnect the top of the shocks from the frame shock mount. Use a 14mm and a 17mm wrench and socket.

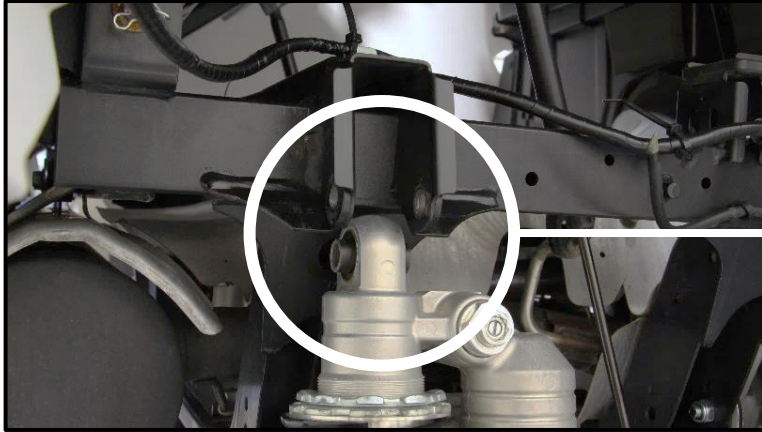

DISCONNECT BOTH SIDE

- Disconnect the top of the sway bar link from the swing arm. Use a 17mm wrench and a 5mm Allen key.
- Remove the sway bar from the UTV. Use a 14mm and a 17mm wrench and socket.

INSTALLATION

1. Install (1x) rear bracket (02) to the shock mount. Use (1x) M12-1.75 x 110mm bolt and (2x) M12 washer.

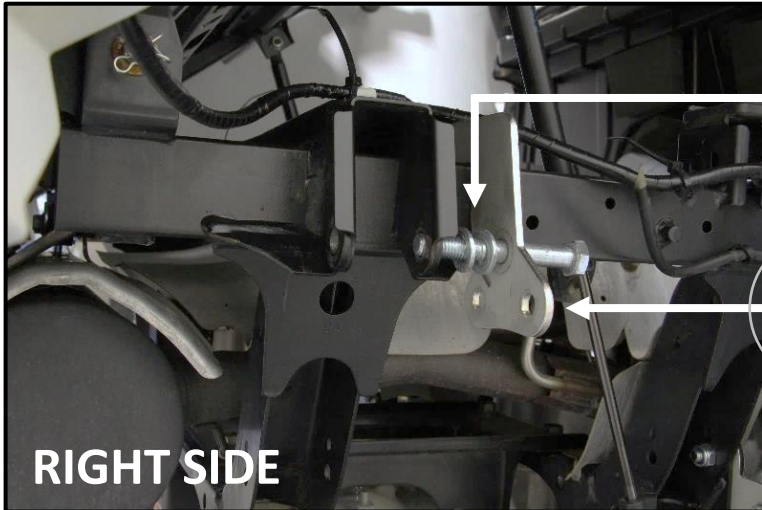

WASHERS

02

RIGHT SIDE

2. Insert (1x) 1-9/16" Lg. spacer between the frame shock mount.

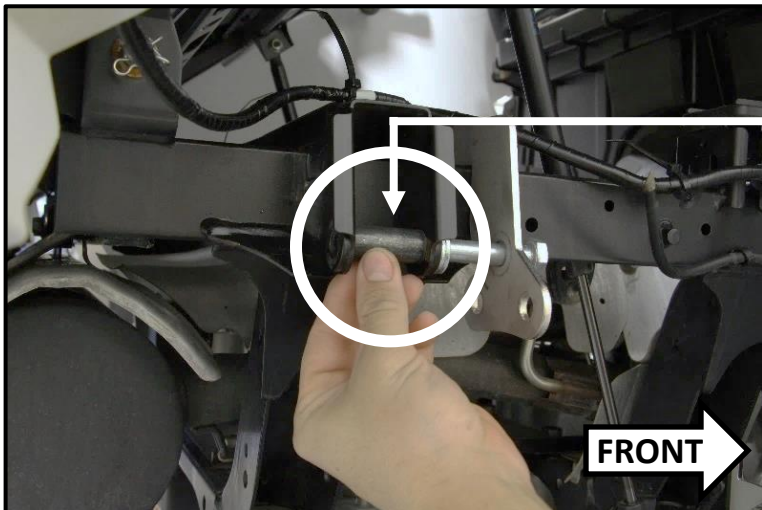

SPACER

FRONT

3. Insert (1x) 7/8" Lg. spacer at the end of the bolt.

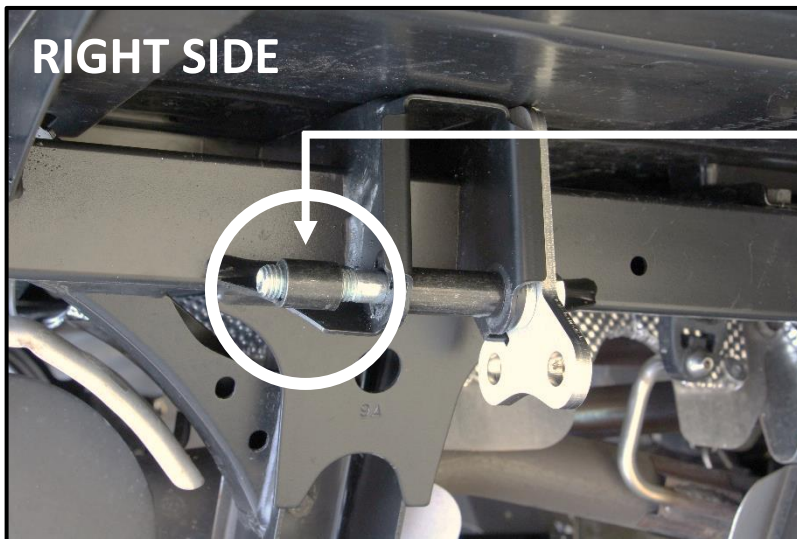

SPACER

4. Complete the assembly with the other appropriated rear bracket. Secure with (1x) M12 washer and (1x) M12-1.75 lock nut.
- **NOTE 1:** You have one bracket that is for the left side and another one for the right side. See image below.
 - **NOTE 2:** The bottom of the bracket will need to be OUTSIDE of the frame, NOT INSIDE.



5. Secure the bottom of the bracket to the square frame.
- **WOLVERINE 2018 and 2019:** Use (1x) M10-1.50 x 25mm bolt, (1x) M10 washer and (1x) M10-1.50 lock nut.
 - **WOLVERINE 2020:** Use (1x) M10-1.50 x 90mm bolt, (2x) 1" Lg. spacer, (5x) M10 heavy washer, (1x) M10 washer and (1x) M10-1.50 lock nut. See image below.

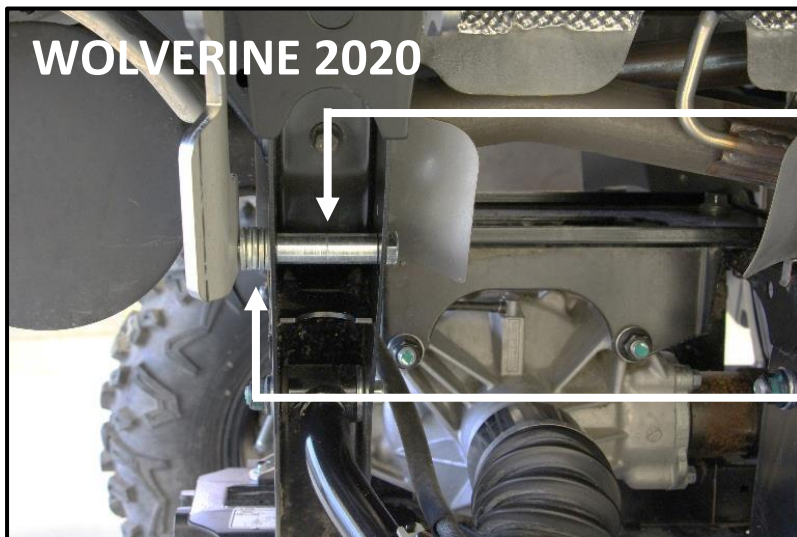

SPACERS

WASHERS

6. Tight completely the lock nut of the step 5. Use a 17mm wrench and socket.
- **NOTE:** Be sure that the top of the bracket is well abutted on the square frame when you will tight the lock nut.

7. Connect the top of the shock to the brackets. Use (1x) M12-1.75 x 110mm bolt, (1x) 7/16" Lg. spacer, (1x) 1-1/8" Lg. spacer, (1x) M12 washer and (1x) M12-1.75 lock nut.

- **REAR LIFT OPTION 01 (IMAGE 8.1):** Choose the outside lift position to have a 2" rear lift, with stiffer suspension.
- **REAR LIFT OPTION 02 (IMAGE 8.2):** Choose the inside lift position to have a 1.5" rear lift, with smoother suspension.

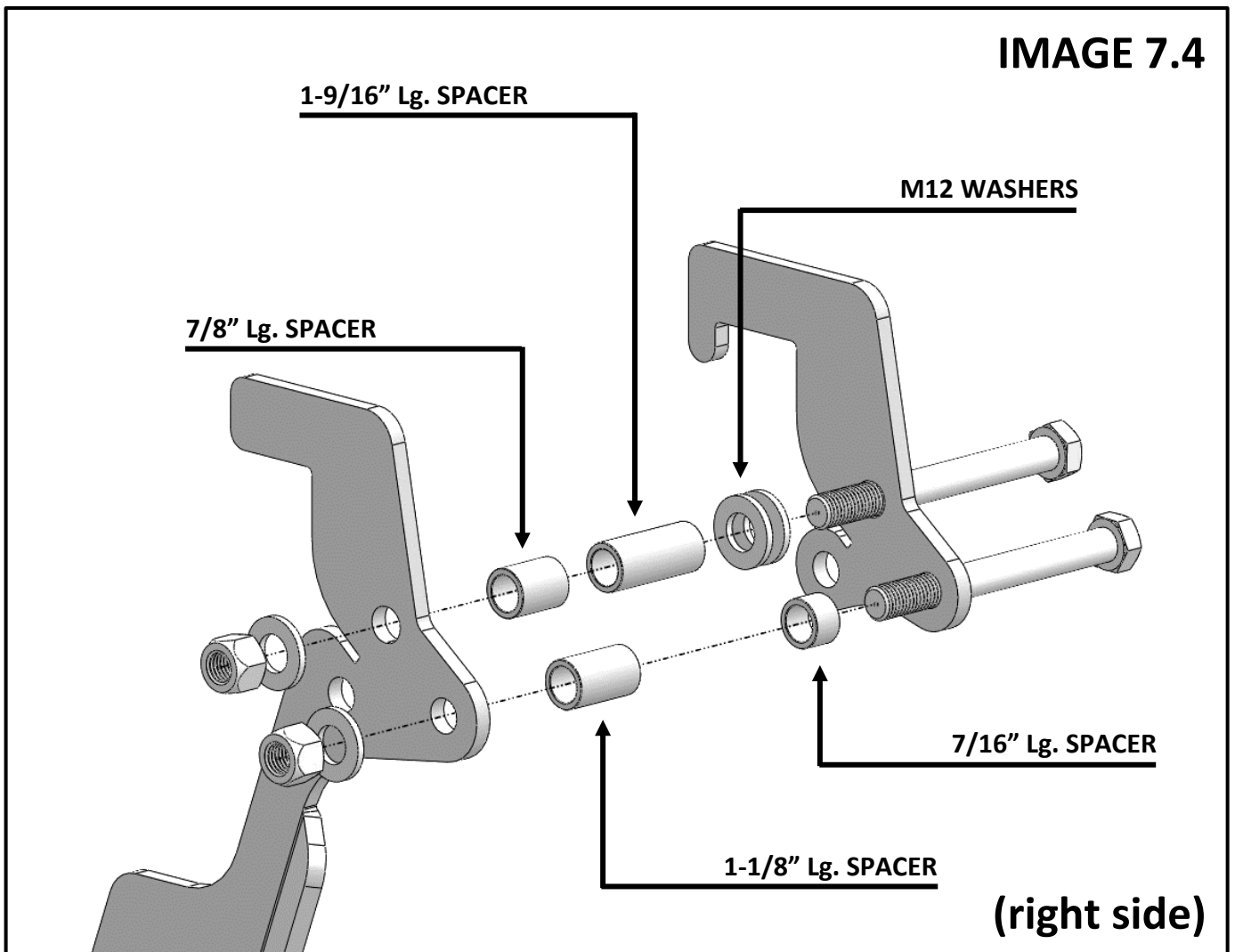
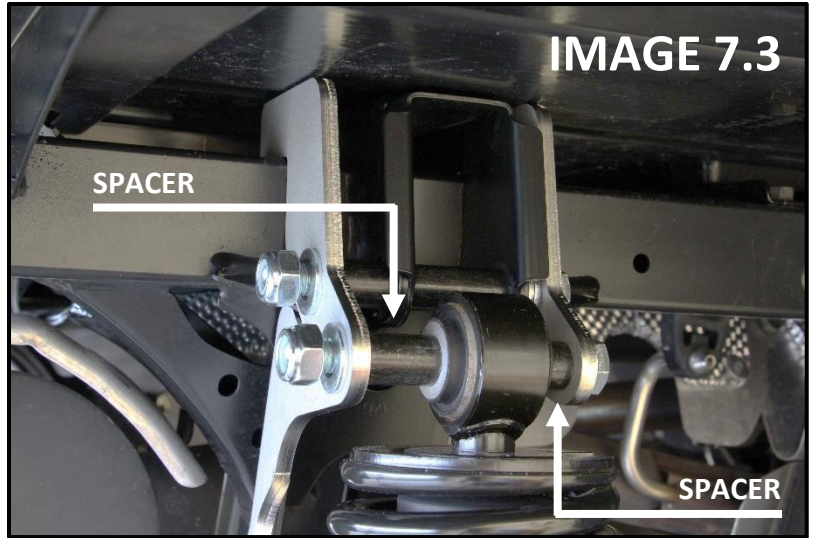
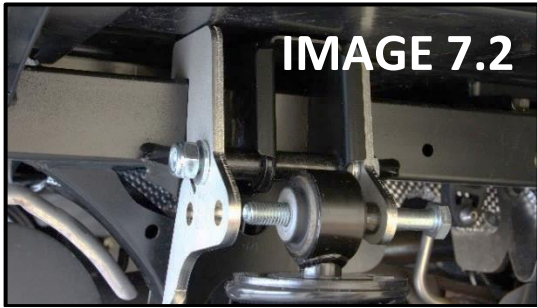

8. Tight all the remaining hardware appropriately at this point. Use a 19mm wrench and socket.

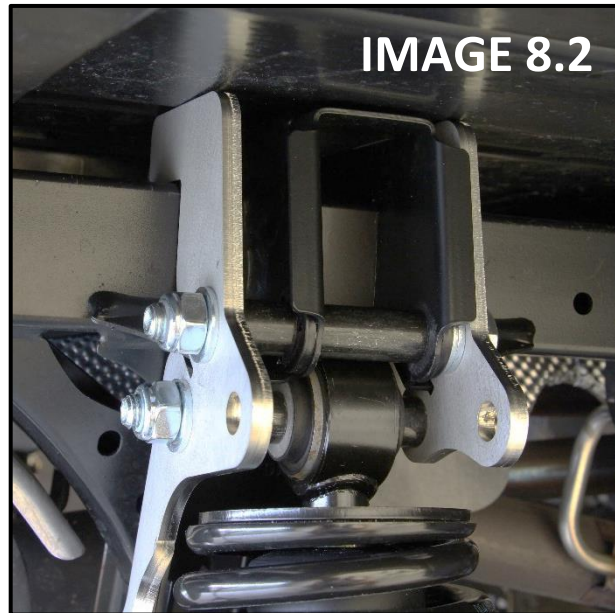

9. Repeat the same steps for the opposite side.
10. Remove the bush stabilizers on the sway bar.
11. Place them on the other side of the bushing that is fixed on the sway bar.
12. Install, on both sides, the new sway bar relocation brackets (05) where the sway bar was fixed before. Use (4x) M10-1.50 x 25mm bolt, (4x) M10 washer and (4x) M10-1.50 lock nut.
13. Put the sway bar back on the UTV. Install the bar on its new position. Use factory hardware.
14. Re-connect the top of the sway bar link to the sway bar, using factory hardware.

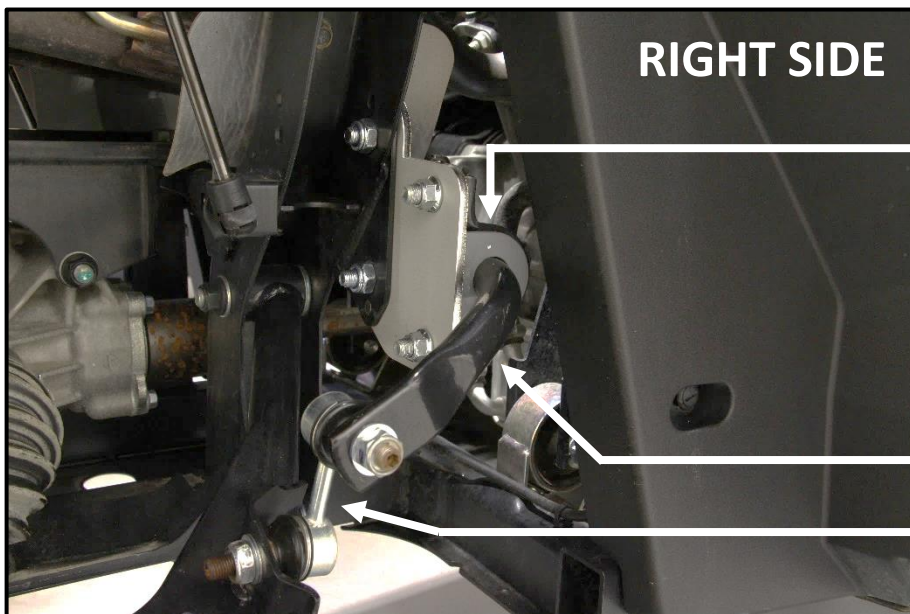

BUSH STABILIZER

SWAY BAR

SWAY BAR LINK

15. Tight all the hardware appropriately. Use a 17mm wrench and socket for the provided M10 hardware.
16. Put the wheels back on the vehicle when the installation is finished. Torque all lugs to factory specification.