



# INSTALLATION INSTRUCTIONS

SKU: **LK-10244**

2" LIFT KIT POLARIS BRUTUS (13-18)

01

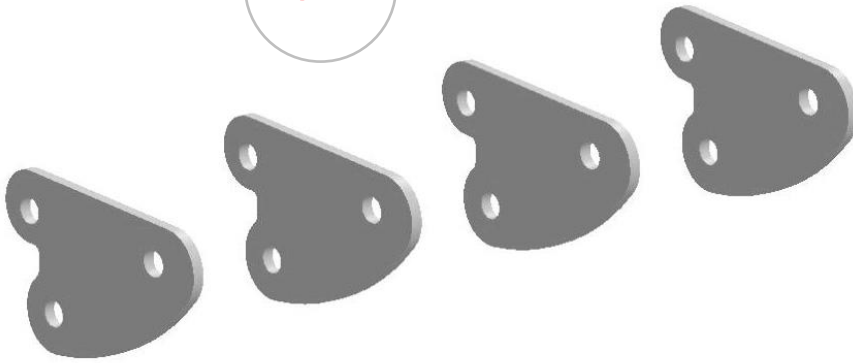

02

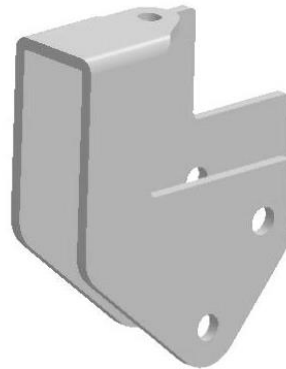

03

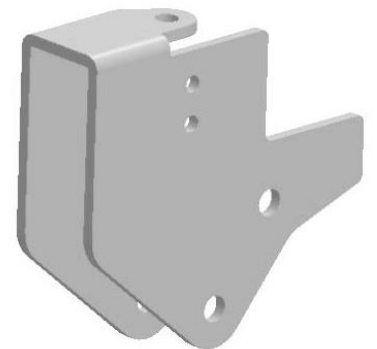

Item	Part No.	Description	Torque	Qty.
<b>LIFT COMPONENTS</b>				
Those items are shown on the first page.				
01	244-01	Front Lift Bracket		4
02	244-02L	Rear Lift Bracket (left side)		1
03	244-02R	Rear Lift Bracket (right side)		1
<b>FRONT HARDWARE</b>				
Those items are included with each kit to install the front lift components.				
04	A-1008	M10 Flat Washer		2
05	A-1058	M10 Flat Heavy Washer		4
06	A-1509	M10-1.50 Flange Lock Nut	36 to 38 ft-lbs	4
07	A-3021	M10-1.50 x 60mm Hex Flange Bolt	36 to 38 ft-lbs	4
08	B-5216	12mm ID. x 11/16" OD. x 1" Lg. Spacer		4
<b>REAR HARDWARE</b>				
Those items are included with each kit to install the rear lift components.				
04	A-1008	M10 Flat Washer		2
09	A-1505	M6-1.00 Flange Lock Nut	7.8 ft-lbs	4
10	A-1507	M8-1.25 Flange Lock Nut	18.75 ft-lbs	2
06	A-1509	M10-1.50 Flange Lock Nut	36 to 38 ft-lbs	4
11	A-2605	M6-1.00 x 20mm Hex Flange Bolt	7.8 ft-lbs	4
12	A-2805	M8-1.25 x 20mm Hex Flange Bolt	18.75 ft-lbs	2
07	A-3021	M10-1.50 x 60mm Hex Flange Bolt	36 to 38 ft-lbs	4
13	B-5003	10mm ID. x 5/8" OD. x 3/16" Lg. Spacer		2
08	B-5216	12mm ID. x 11/16" OD. x 1" Lg. Spacer		2

# PLEASE READ AND UNDERSTAND BEFORE THE INSTALLATION

## CUSTOMER AND/OR END USER:

---

This product is designed for use on ATVs and/or UTVs to increase ground clearance and fender clearance. Purchasers should be aware that use of this product may increase the frequency of required maintenance, part wear...

Using a lift kit will raise the center of gravity on your ATV and/or UTV, increasing risk of roll-over, injury and death on ALL types of terrain. It's YOUR RESPONSIBILITY to always inform other operators and passengers of this vehicle about the added risks.

Our products are designed to best fit user's ATV/UTV under stock conditions. Adding, modifying, or fabricating any OEM or aftermarket parts will void warranty. PERFEX Industries products could interfere with other aftermarket accessories. If the user has aftermarket products on machine, please contact PERFEX Industries to verify that they will work together.

Adding aftermarket suspension components and/or more aggressive tires can cause breakage of other OEM driveline components such as differentials, axles or drive shafts.

We ALWAYS recommend that wider tires and/or wheel spacers be used to achieve a wider stance and to improve stability of the ATV and/or UTV. Riders should be advised that the handling characteristics of a taller ATV and/or UTV are different and require extra care when riding, particularly on side hills or off-camber situations. If you further raise the center of gravity by adding taller tires, heavy loads to racks or seats, or by any other means, the ATV and/or UTV must be operated with even more care, at slower speeds and on relatively flat ground. All turns should be done at a slow speed, even on level ground.

Operation of an ATV and/or UTV with or without modified suspension components, while or shortly after consuming alcohol or drugs, subjects the rider to the risk of serious bodily harm or possible death. This risk is compounded if the rider does not wear an approved helmet and other safety gear.

PERFEX Industries urges that all approved safety gear be worn when riding an ATV and/or UTV as a driver or passenger.

By purchasing and installing PERFEX Industries products, user agrees that should damages occur, PERFEX Industries will not be held responsible for loss of time, use, labor fees, replacement parts, or freight charges. WE (PERFEX Industries) will not be held responsible for any direct, indirect, incidental, special, or consequential damages that result from any product purchased from PERFEX Industries.

**PLEASE TAKE NOTE: The total liability of seller to user for all damages, losses, and causes of action, will never exceed the total purchase price paid for the product that gives rise to the claim.**

## DEALER AND/OR OTHER INSTALLERS:

---

You are responsible for informing your customer and end user of the information contained above and the increased potential hazards of operating an ATV and/or UTV equipped with modified suspension components.

If you install any suspension modifying components, it is your responsibility to also install a warning label prominently in view of the driver and in prominent view of the driver and passenger on UTVs and multi-passenger ATVs.

They should also be instructed to notify anyone operating the vehicle, as well as any passengers, that said vehicle is modified.

As discussed above, it is critically important that they be instructed in the need for slower speed operation, regardless of terrain, after this lift kit is installed.

# FRONT INSTALLATION INSTRUCTIONS

## PREPARATION

- Using a jack under center of front end, lift until the front wheels leave the ground.
- Remove the wheels.
- Disconnect the top of the shocks from the frame shock mount. Save factory hardware.

## INSTALLATION

1. Install one front bracket outside of the shock mount, face of the front of the UTV. Use 2 M10-1.50 x 60mm bolts and 2 3/8" heavy washers. Put the washers between the bracket and the shock mount, as shown below.

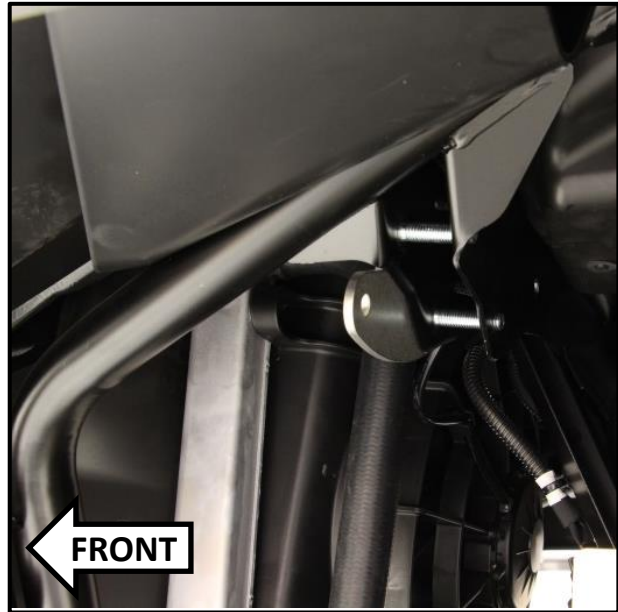

2. Insert one spacer on each bolt, inside of the shock mount.

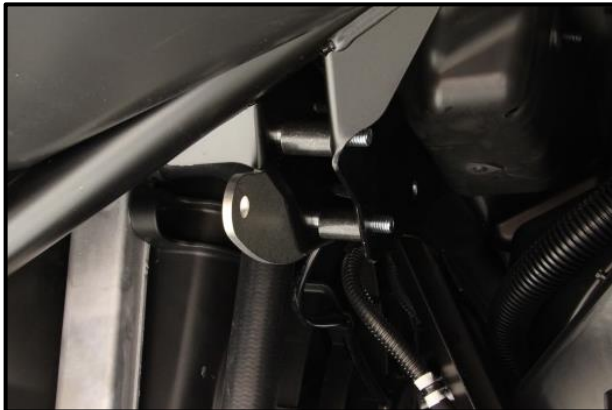

3. Insert another one front bracket to the assembly, inside of the shock mount.



4. Secure with 2 M10-1.50 lock nuts. Don't tight completely at this point.
5. Connect the top of the shock using the factory hardware and one M10 washer. Put the M10 washer between the front outside bracket and the shock eyelet.

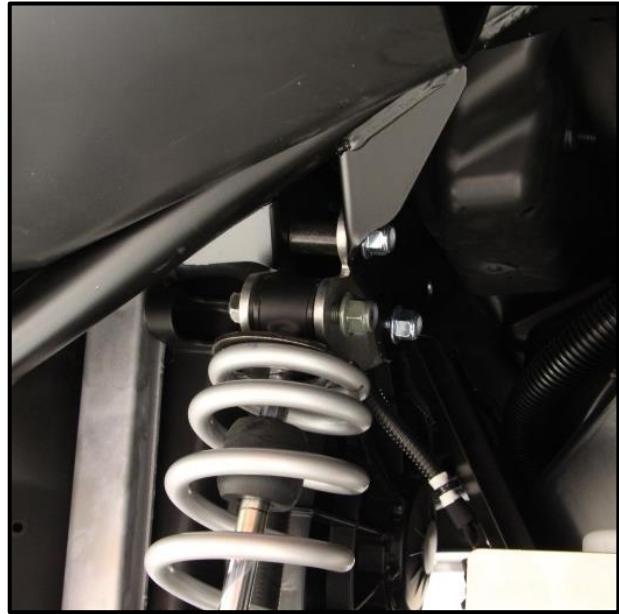
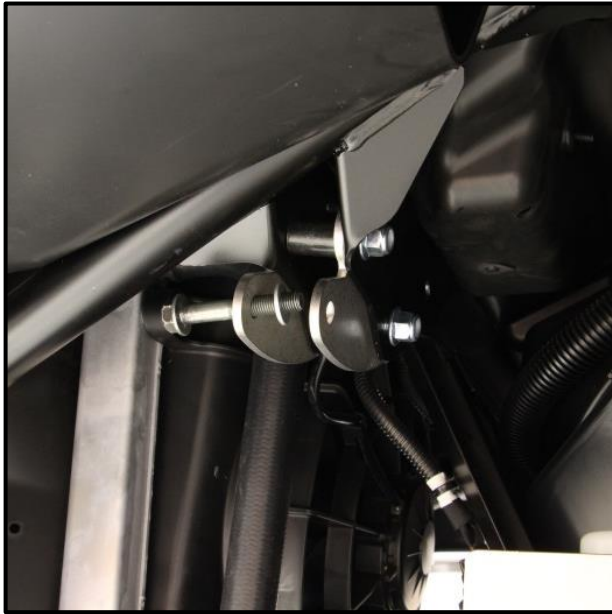

6. Tight all the hardware appropriately at this point.
7. Repeat the same steps for the opposite side.
8. Put the wheels back on the vehicle when the installation is finished. Torque all lugs to factory specification.

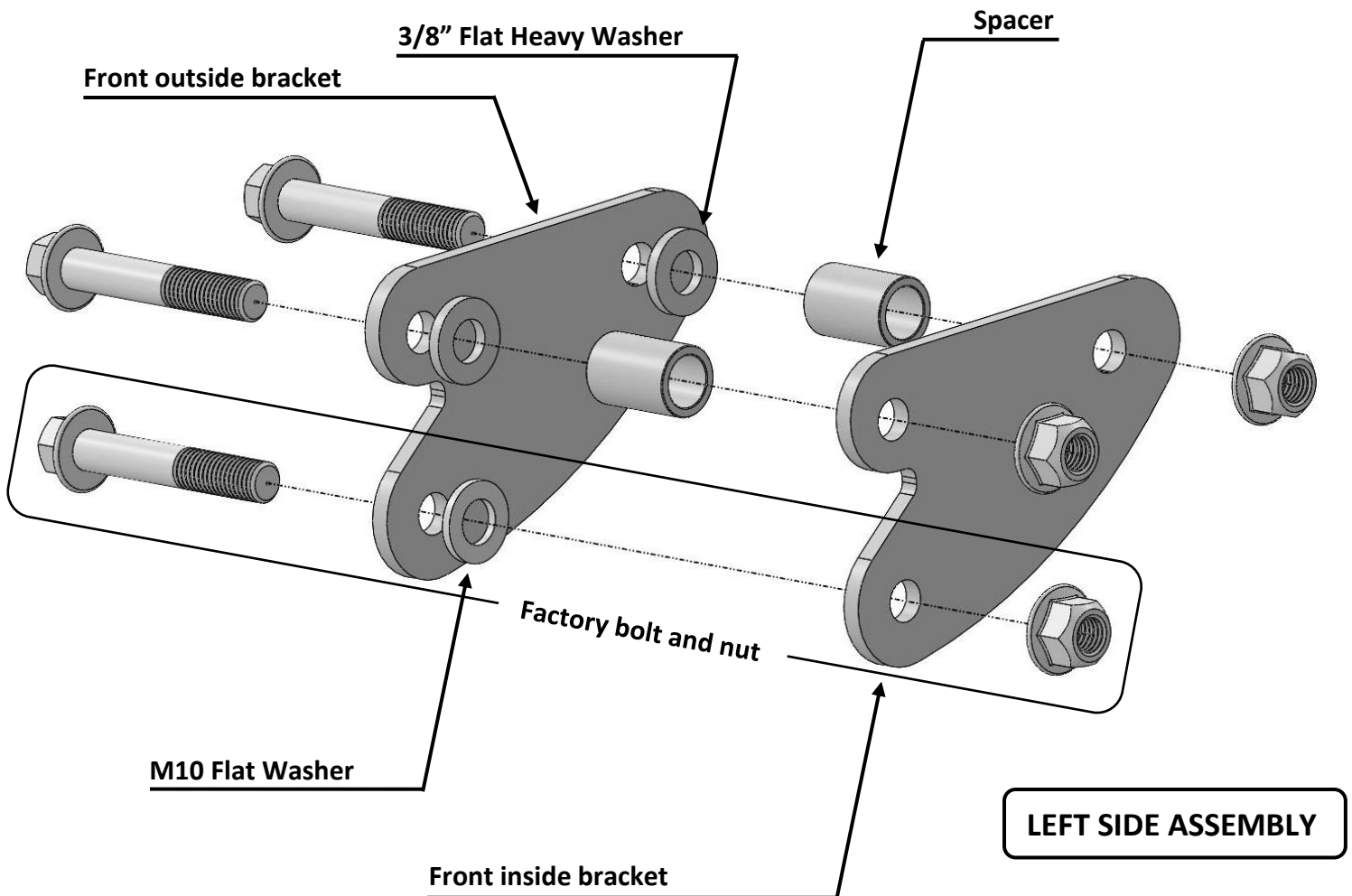



# REAR INSTALLATION INSTRUCTIONS

## PREPARATION

- Using a jack under center of rear end, lift until the rear wheels leave the ground.
- Sit the rear of the UTV on two supports placed on each side of the rear square frame.
- Remove the wheels.
- Then, place the jack under the rear axle brace.
- Disconnect the top of the shock from the frame shock mount. You will be able to drop the suspension using the jack under the rear axle brace.
- Remove the bolts that fix the bracket just under the shock mount.

## INSTALLATION

1. Insert the appropriate rear bracket (you have one for the left side and one for the right side) to the frame shock mount. Refer to the image below (right side shown).

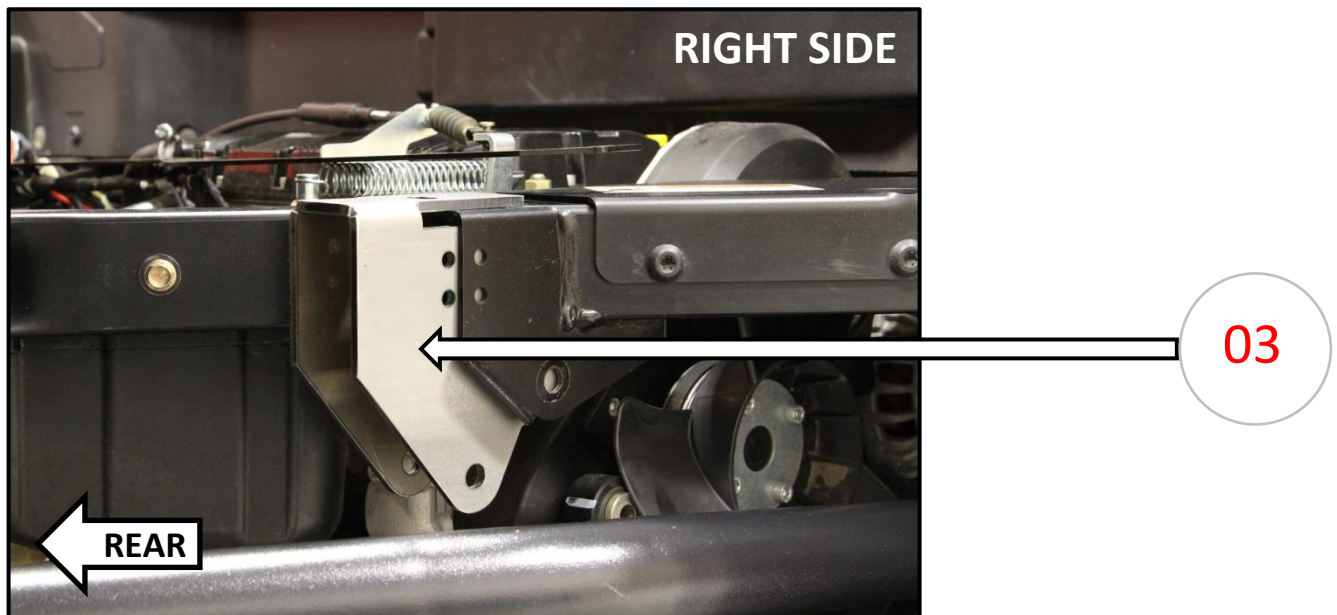

2. Install the bracket to the shock mount. Use M10-1.50 x 60mm bolt, one big spacer, one small spacer and M10-1.50 lock nut.
  - Put the big spacer (1" long) inside of the shock mount.
  - Put the small spacer (3/16" long) outside of the shock mount, between the frame and the bracket.
  - Secure with M10-1.50 lock nut at the end of the bolt.

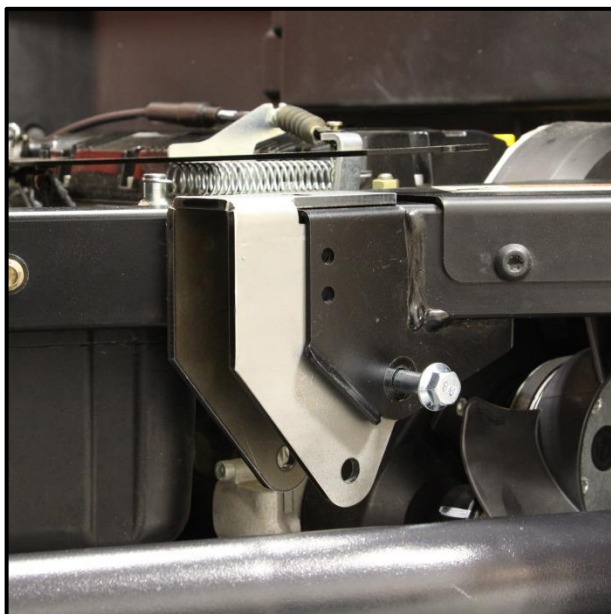

3. Secure the bracket to the frame.

- Use two M6-1.00 bolts and lock nuts for the side of the bracket.
- Use one M8-1.25 bolt for the top of the bracket. Don't forget to re-install the long factory plate.

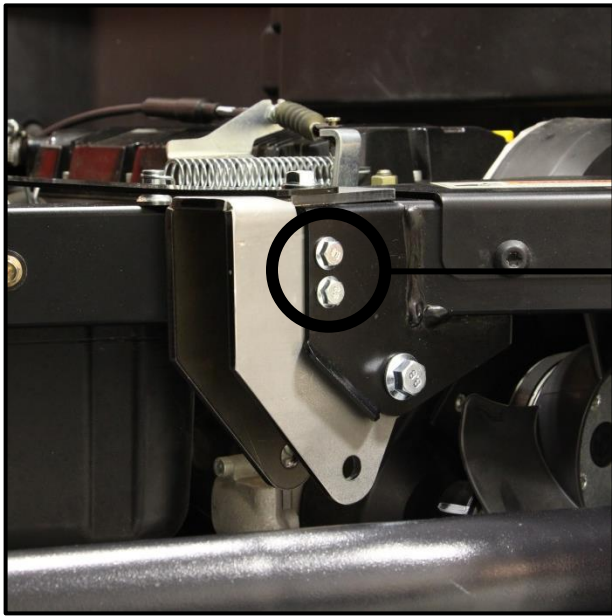

**M6-1.00 Hardware**

4. Connect the top of the shock to the bracket. Use M10-1.50 x 60mm bolt, M10 washer and M10-1.50 lock nut. Put the washer between the shock eyelet and the bracket, on the interior side.

5. Tight all the hardware appropriately at this point.

6. Repeat the same steps for the opposite side.

7. Put the wheels back on the vehicle when the installation is finished. Torque all lugs to factory specification.

