

THIS SHEET INCLUDES FITTING INSTRUCTIONS FOR THE FOLLOWING PARTS:

Secondary Alternator Cover Part No. EC-MT07-2014-1-GBR / Secondary Clutch Cover Part No. EC-MT07-2014-2-GBR /  
 Secondary Water Pump Cover Part No. EC-MT07-2014-5-GBR / Paddock Stand Bobbin Set Part No. BA12-6-GBR-SET (MT-07 Tracer model only)  
 Secondary Water Pipe Cover Part No. WPC-MT07-2014 / Bullet Frame Sliders - Street - Part No. FS-MT07-2014-LHS-S & FS-MT07-2014-RHS-S



**SECONDARY ALTERNATOR COVER – PART NO. EC-MT07-2014-1-GBR**

1. Place your bike in an upright position when fitting the Alternator as you will lose a small amount of engine oil when you remove Bolt 3.
2. Remove 4 existing bolts from the stock Alternator cover, shown as position Bolt 1, 2, 3 & 4.
2. Place the Secondary Alternator Cover over the stock cover.
3. Assemble 4 replacement **M6X50A2** bolts loosely in the correct position as shown.
4. Tighten bolts to a Torque of 10Nm as per Manufacturer's recommendations. **DO NOT OVERTIGHTEN.**

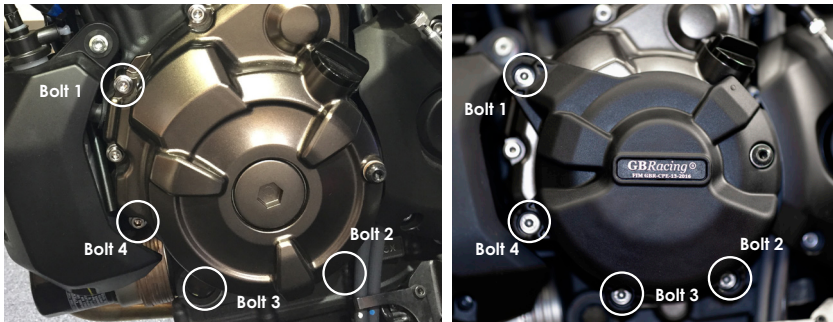

**Bolt 1**  
**M6X50A2 - 10Nm**

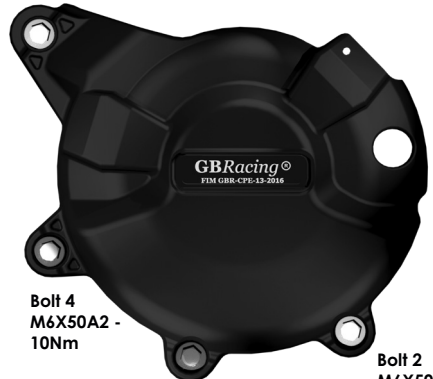

**Bolt 4**  
**M6X50A2 - 10Nm**

**Bolt 3**  
**M6X50A2 - 10Nm**

**Bolt 2**  
**M6X50A2 - 10Nm**

**SECONDARY CLUTCH COVER**  
**PART NO. EC-MT07-2014-2-GBR**

**Please note: When fitting to the Yamaha Ténéré 700, please remove the small OE plastic cover before fitment.**

1. Remove 4 existing bolts from the stock Clutch cover, shown as position Bolt 1, 2, 3 & 4.
2. Place the Secondary Clutch Cover over the stock cover.
3. Assemble 4 replacement bolts loosely in the correct positions as shown.
4. Tighten bolts to a Torque of 10Nm as per Manufacturer's recommendations. **DO NOT OVERTIGHTEN.**

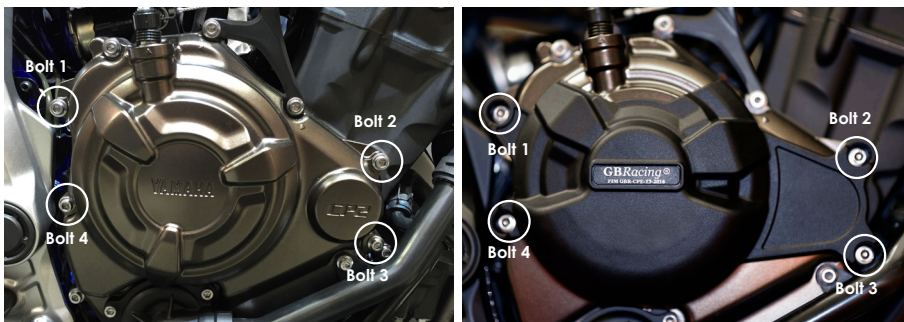

**Bolt 1**  
**M6X35A2 - 10Nm**



**Bolt 2**  
**M6X35A2 - 10Nm**

**Bolt 4**  
**M6X35A2 - 10Nm**

**Bolt 3**  
**M6X35A2 - 10Nm**

**SET: Engine Cover Set: EC-MT07-2014-SET-GBR**

Secondary Alternator Cover Part No. EC-MT07-2014-1-GBR / Secondary Clutch Cover Part No. EC-MT07-2014-2-GBR

**PADDOCK STAND / BOBBIN SET**  
**PART NO. BA12-6-GBR-SET**

**THIS PART FITS MT-07 TRACER MODEL ONLY:**

1. Assemble M6 x 40mm Bolt & M6 Washer through the moulded bobbin.
2. Tighten bolts to swing arm boss, 8 Nm.  
**DO NOT OVERTIGHTEN**

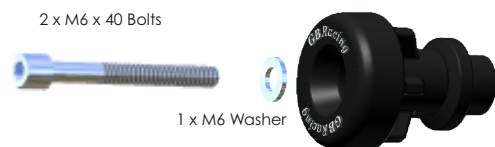

2 x M6 x 40 Bolts

1 x M6 Washer

1 x Moulded Paddock Stand / Bobbin

**SECONDARY WATER PUMP COVER – PART NO. EC-MT07-2014-5-GBR**

Please note:

- Always fit with a cold engine.
  - Coolant may leak whilst fitting the protective cover, so prepare with a container underneath the bike.
1. Remove 3 existing bolts from the stock water pump cover, shown as position Bolt 1, 2 & 3.
  2. Place the Secondary water pump cover over the stock cover.
  3. Assemble 3 replacement **M6X25A2** bolts loosely in the correct position as shown.
  4. Tighten bolts to a Torque of 10Nm as per Manufacturer's recommendations. **DO NOT OVERTIGHTEN.**
  5. Check coolant levels.

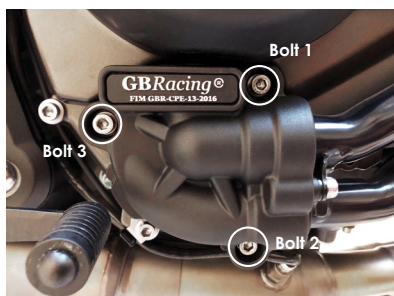
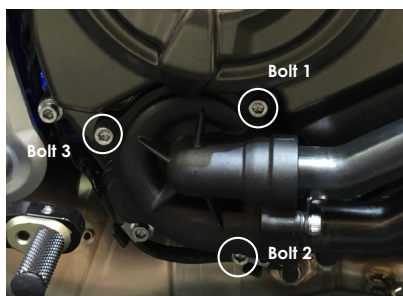
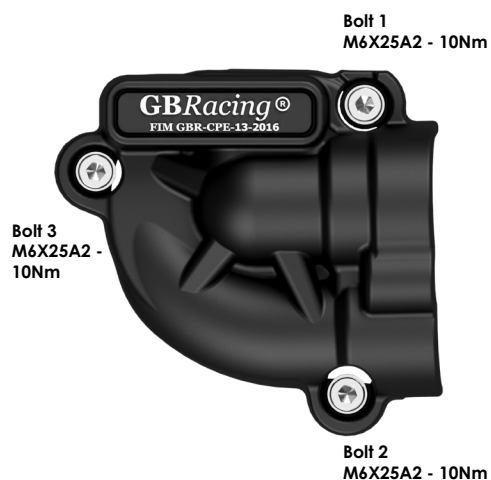

**WATER PIPE COVER – PART NO. WPC-MT07-2014**

1. Ensure engine is cold.
2. Remove 3 existing bolts from the correct locations.
3. Place the water pipe cover over the water pipes.
4. Assemble 3 replacement bolts from the stock water pipe cover, shown as position Bolt 1, 2 & 3.
5. Tighten bolts to a Torque of 10Nm as per Manufacturer's recommendations. **DO NOT OVERTIGHTEN.**

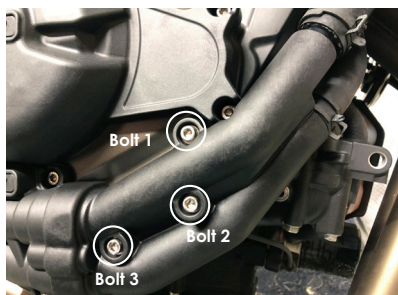
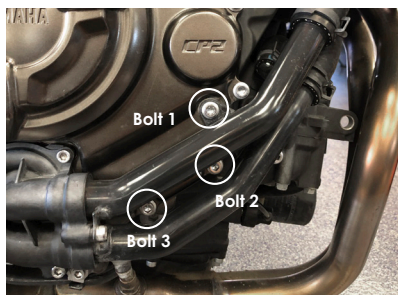
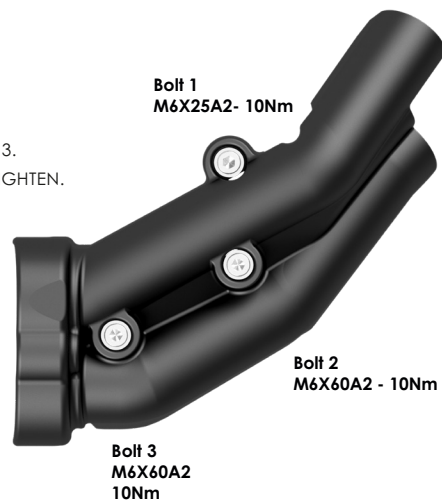

**BULLET FRAME SLIDER - LEFT HAND SIDE - STREET**  
**PART NO. FS-MT07-2014-LHS-S**



**BULLET FRAME SLIDER - RIGHT HAND SIDE - STREET**  
**PART NO. FS-MT07-2014-RHS-S**

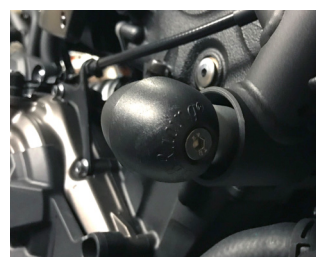

**INSTRUCTIONS FOR THESE PARTS:**

1. Remove upper engine mounting bolt.
2. Assemble bolt through the aluminium bush into correct position.
3. Tighten to 60NM torque.
4. Slide bullet moulding onto aluminium bush.
5. Screw M6 bolt into front of bullet moulding hand tight.