

THIS SHEET INCLUDES FITTING INSTRUCTIONS FOR THE FOLLOWING PARTS:

Secondary Alternator Cover Part No. EC-GSXR1000-L7-1-GBR / Secondary Clutch Cover Part No. EC-GSXR1000-L7-2-GBR /
Secondary Pulse / Timing Cover Part No. EC-GSXR1000-L7-3-GBR / Secondary Water Pump Cover Part No. EC-GSXR1000-L7-5-GBR /
Lower Chain Guard Part No. CGA10-GBR / Paddock Stand/Bobbin Set Part No. BA12-8-GBR-SET / Bullet Frame Sliders Set Part No. FS-GSXR1000-L7-S



SECONDARY ALTERNATOR COVER PART NO. EC-GSXR1000-L7-1-GBR

- 1 Remove the fairing.
- 2 Remove 4 existing bolts from the Stock Alternator cover, shown as position Bolt 1, 2, 3 & 4
Please note: Do not remove the fairing bracket.
- 3 Place the Secondary Alternator Cover over the Stock cover.
- 4 Assemble 4 replacement bolts (3xM6X40HHF & 1xM6X50HHF) loosely in the correct position as shown.
- 5 Tighten bolts to a Torque of 10Nm as per Manufacturer's recommendations. DO NOT OVERTIGHTEN.
- 6 Replace the fairing.

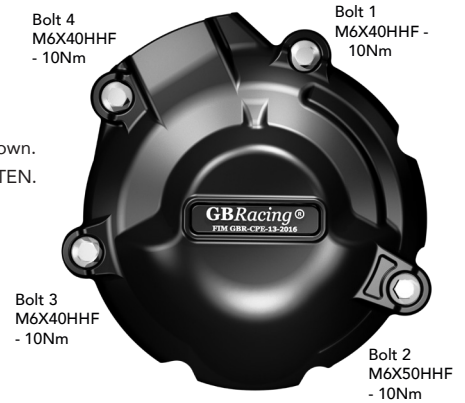
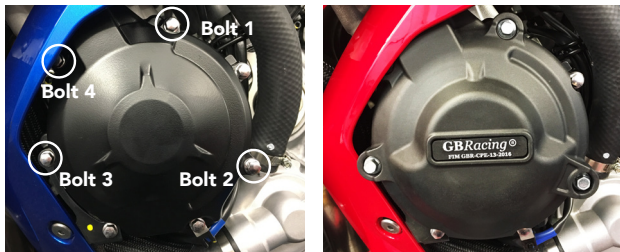

SECONDARY CLUTCH COVER PART NO. EC-GSXR1000-L7-2-GBR

- 1 Remove the fairing.
- 2 Remove 4 existing bolts from the stock Clutch cover, shown as position Bolt 1, 2, 3 & 4.
- 3 Place the Secondary Clutch Cover over the stock cover.
- 4 Assemble 4 replacement bolts (M6X35HHF) loosely in the correct position as shown.
- 5 Tighten bolts to a Torque of 10Nm as per Manufacturer's recommendations. DO NOT OVERTIGHTEN.
- 6 Replace the fairing.

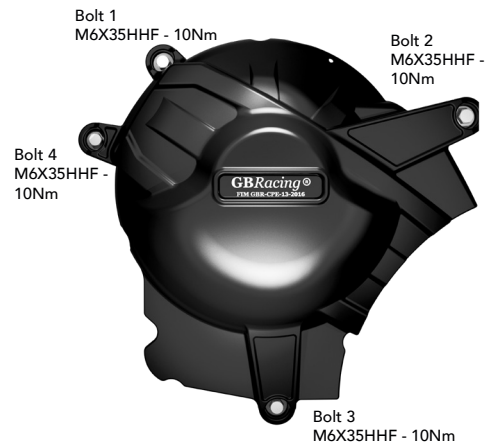
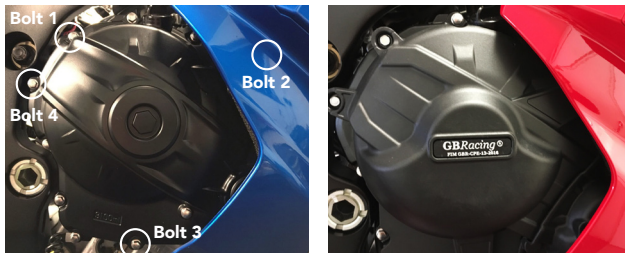

SECONDARY PULSE COVER PART NO. EC-GSXR1000-L7-3-GBR

- 1 Remove the fairing.
- 2 Remove 3 existing bolts from the stock Pulse cover, shown as position Bolt 1, 2 & 3. *Note :* Bolt 1 has a sealing washer that needs retaining for re-use later.
- 3 Assemble one of the M6X35HHF replacement bolts through the Secondary Pulse Cover at position 1, then re-assemble the stock sealing washer as shown above (See Fig.1).
- 4 Place the Secondary Pulse Cover over the OE stock cover ensuring the fairing bracket is sandwiched between the OE cover & GBRacing Secondary Pulse Cover at Bolt Position 2 (See Fig.2).
- 5 Assemble the remaining replacement bolts loosely in the correct position.
- 6 Tighten all bolts to a Torque of 10Nm as per Manufacturer's recommendations. DO NOT OVERTIGHTEN.
- 7 Replace the fairing. *Please note:* when refitting the fairing it will feel tighter due to the sound cushioning on the inside of the fairing pushing up against the secondary cover. If reinstalled correctly this will not damage either component.

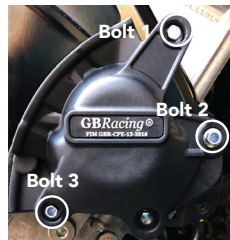
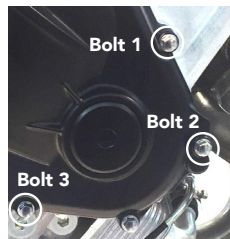
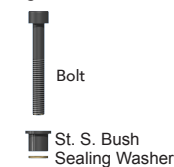
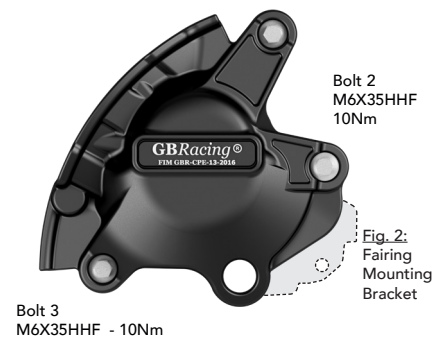

Fig.1



Bolt 1
M6X35HHF - 10Nm
- See Fig. 1



Bolt 2
M6X35HHF
10Nm

Fig. 2:
Fairing
Mounting
Bracket

SECONDARY WATER PUMP COVER
PART NO. EC-GSXR1000-L7-5-GBR

- 1 Fitting requires a COLD engine.
- 2 **See Fig 1:** Gently loosen Jubilee clip 1 and rotate clip to the left (as shown). Gently loosen Jubilee clip 2 & push clip back towards the engine to create space to fit secondary cover. Move cable 3 to tuck in behind OE cover as shown.
- 3 Place secondary water pump cover over stock cover by sliding in from the right hand side.
- 4 Assemble replacement Bolt 1 into position first - do not tighten. Then assemble Bolt 2 into position - do not tighten.
- 5 Do not attempt to tighten bolts until both are in position and secondary water pump cover feels seated in position.
- 8 Tighten bolts to a Torque of 10Nm. **DO NOT OVERTIGHTEN.**

Fig 1

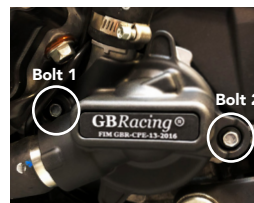
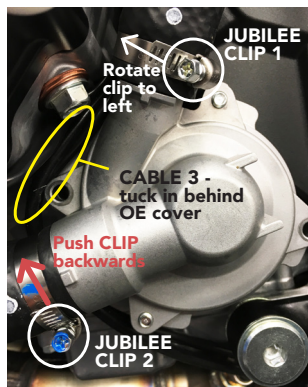

Bolt 1
M6X40HHF -
10Nm



Bolt 2
M6X40HHF -
10Nm

BULLET FRAME SLIDER - LEFT & RIGHT HAND SIDE - RACE - PART NOS. FS-GSXR1000-L7-RHS-R & FS-GSXR1000-L7-LHS-R

- 1 Remove the fairing.
- 2 Unscrew the engine mounting sufficiently so that the bolt will mark the inside of the fairing.
- 3 Mark the head of the unscrewed bolt with a marker pen and assemble the fairing back, pushing in the area of the unscrewed bolt head.
- 4 Remove the fairing and drill a 22mm Diameter through hole where the head of the engine mount bolt has marked.
- 5 Now remove the engine bolt fully.
- 6 Replace the fairing.
- 7 Assemble replacement engine mount bolt through the aluminium bush into correct position.
- 8 Tighten to 75NM torque.
- 9 Slide bullet moulding onto aluminium bush.
- 10 Screw M6 bolt into front of bullet moulding hand tight.

LEFT HAND SIDE



RIGHT HAND SIDE



BULLET FRAME SLIDER - LEFT & RIGHT HAND SIDE - STREET - PART NO. FS-GSXR1000-L7-RHS-S & FS-GSXR1000-L7-LHS-S

- 1 Remove the fairing.
- 2 Unscrew the engine mounting sufficiently so that the bolt will mark the inside of the fairing.
- 3 Mark the head of the unscrewed bolt with a marker pen and assemble the fairing back, pushing in the area of the unscrewed bolt head.
- 4 Remove the fairing and drill a 22mm Diameter through hole where the head of the engine mount bolt has marked.
- 5 Now remove the engine bolt fully.
- 6 Replace the fairing.
- 7 Assemble replacement engine mount bolt through the aluminium bush into correct position.
- 8 Tighten to 75NM torque.
- 9 Slide bullet moulding onto aluminium bush.
- 10 Screw M6 bolt into front of bullet moulding hand tight.

LEFT HAND SIDE



RIGHT HAND SIDE



LOWER CHAIN GUARD PART NO. CGA10-GBR

- 1 Assemble 2 bolts and washers through the lower chain guard into the Black Anodised aluminium mounting block CGA10-2.
- 2 Position the assembly underneath the swing arm, closing the gap to the rear sprocket.
Note : There should be a 5mm minimum gap from the bike chain to the lower chain guard.
- 3 Mark off the chosen hole positions.
- 4 Drill & Tap the marked holes , M6 - (Drill 5mm Dia. for tapping)
- 5 Disassemble the Black Anodised block from the assembly, and mount the block to the underside of the swing arm using the remaining 2 bolts and washers.
- 6 Re-assemble the lower chain guard to the fixed bracket.



2 x Bolts & Washers
M6x20 - 10Nm



PADDOCK STAND / BOBBIN SET PART NO. BA12-8-GBR-SET

- 1 Assemble M8 x 40mm Bolt through the moulded bobbin.
- 2 Tighten bolts to swing arm boss, 8 Nm.
DO NOT OVERTIGHTEN

1 x M8 x 40 Bolt



1 x Moulded Paddock Stand / Bobbin