

THIS SHEET INCLUDES FITTING INSTRUCTIONS FOR THE FOLLOWING PARTS:

Secondary Alternator Cover Part No. EC-Z650-2017-1-GBR / Secondary Clutch Cover Part No. EC-Z650-2017-2-GBR /  
Secondary Pulse Cover Part No. EC-Z650-2017-3-GBR / Paddock Stand Bobbin Set Part No. BA12-8-GBR-SET /  
Lower Chain Guards Part No. CGA09-GBR & CGA29-GBR



**SECONDARY ALTERNATOR COVER PART NO. EC-Z650-2017-1-GBR**

1. *For Model Ninja 650 Only:* Remove nearside lower belly panel.  
The lower part of the main fairing panel will need to be loosened to allow for access to Bolt 4 in terms of its removal and replacement.
2. Remove 4 existing bolts from the stock Alternator cover, shown as position Bolt 1, 2, 3 & 4.
3. Place the Secondary Alternator Cover over the stock cover.
4. Assemble 4 replacement bolts loosely in the correct positions as shown.
5. Tighten bolts to a Torque of 11Nm as per Manufacturer's recommendations. **DO NOT OVERTIGHTEN.**
6. *For Model Ninja 650 Only:* Replace lower belly panel.

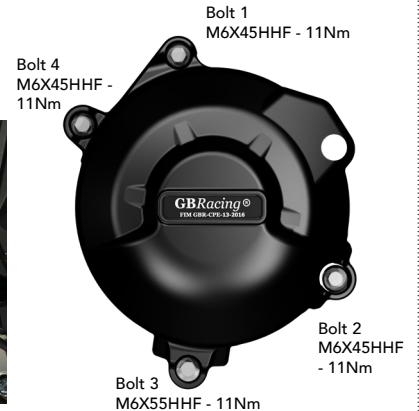
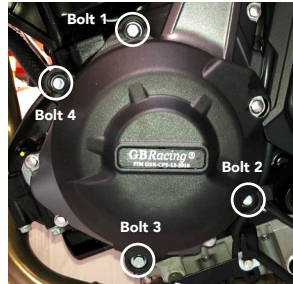

**SECONDARY CLUTCH COVER PART NO. EC-Z650-2017-2-GBR**

1. Remove 4 existing bolts from the Clutch cover, shown as position Bolt 1, 2, 3 & 4.  
*Please note: Fairing around Bolt 1 just needs lightly pushing to get to Bolt 1 (see Fig.1).*
2. Place the Secondary Clutch Cover over the stock cover.
3. Assemble 4 replacement bolts M6X35HHF loosely in the correct position as shown.
4. Tighten bolts to a Torque of 11Nm as per Manufacturer's recommendations.  
**DO NOT OVERTIGHTEN.**

Fig.1

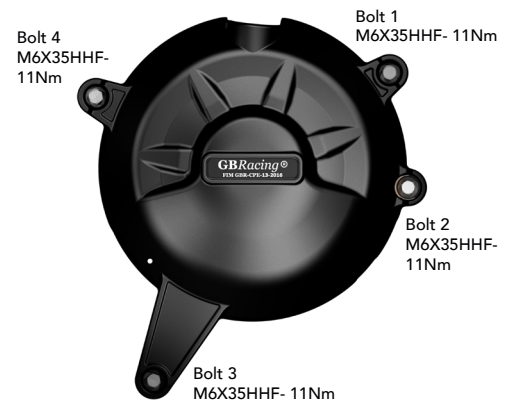
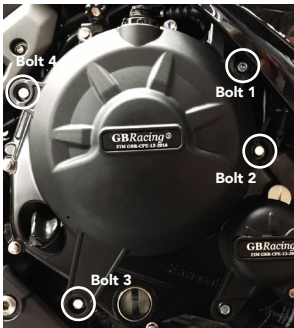

**SECONDARY PULSE COVER PART NO. EC-Z650-2017-3-GBR**

1. Remove Lower Fairing Bolt - see Fig.1
2. Remove 3 existing bolts from the Pulse cover, shown as position Bolt 1, 2, & 3
3. Place the Secondary Pulse Cover over the stock cover. Assemble 3 replacement bolts - M6X30HHF loosely in the correct position as shown.
4. Tighten bolts to a Torque of 11Nm as per Manufacturer's recommendations.
5. Replace Lower Fairing Bolt. **DO NOT OVERTIGHTEN.**

Fig.1

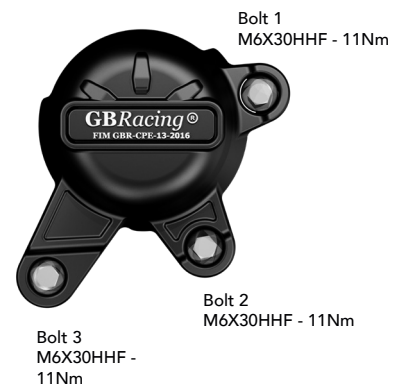



**PADDOCK STAND / BOBBIN SET PART NO. BA12-8-GBR-SET**

- 1 Assemble M8 x 40mm Bolt through the moulded bobbin.
- 2 Tighten bolts to swing arm boss, 8 Nm.  
DO NOT OVERTIGHTEN

1 x M8 x 40 Bolt



1 x Moulded Paddock Stand / Bobbin

**LOWER CHAIN GUARD PART NO. CGA09-GBR**

- 1 Assemble 2 off M6 x 20mm bolts and washers through the moulded lower chain guard into the Black Anodised aluminium mounting block CGA09-2.
- 2 Position the assembly underneath the swing arm, closing the gap to the rear sprocket. Note : There should be a 5mm minimum gap from the bike chain to the lower chain guard.
- 3 Mark the position of the Black Anodised block, relative to the swing arm.
- 4 Disassemble the assembly, leaving the block to be replaced into the correct position.  
Mark the C/Sunk fixing hole positions on the underside of the swing arm.
- 5 Drill & Tap the marked holes , M6 - (Drill 5mm Dia. for tapping)
- 6 Re-assemble the lower chain guard to the fixed block.



2 x C/Sunk Bolts  
M6x10 - 10Nm  
2 x Bolts &  
Washers  
M6x20 - 10Nm

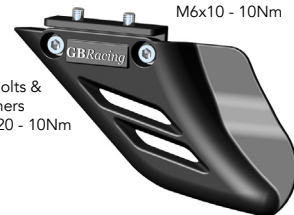

**LOWER CHAIN GUARD PART NO. CGA29-GBR**

- 1 Assemble 2 bolts and washers through the lower chain guard into the Black Anodised aluminium mounting block CGA09-2.
- 2 Position the assembly underneath the swing arm, closing the gap to the rear sprocket.  
*Note : There should be a 5mm minimum gap from the bike chain to the lower chain guard.*
- 3 Mark off the chosen hole positions.
- 4 Drill & Tap the marked holes , M6 - (Drill 5mm Dia. for tapping)
- 5 Disassemble the Black Anodised block from the assembly, and mount the block to the underside of the swing arm using the remaining 2 bolts and washers.
- 6 Re-assemble the lower chain guard to the fixed bracket.

2 x Bolts &  
Washers  
M6x20 - 10Nm



2 x Bolts &  
washers  
M6x10 - 10Nm

**Engine Cover Set: EC-Z650-2017-SET-GBR**

EC-Z650-2017-1-GBR, EC-Z650-2017-2-GBR, EC-Z650-2017-3-GBR

[www.GBRacing.eu](http://www.GBRacing.eu)