

THIS SHEET INCLUDES FITTING INSTRUCTIONS FOR THE FOLLOWING PARTS:

Secondary Alternator Cover Part No. EC-Z300-2014-1-GBR / Secondary Clutch Cover Part No. EC-Z300-2014-2-GBR



SECONDARY ALTERNATOR COVER
PART NO. EC-Z300-2014-1-GBR

1. Remove nearside lower belly panel. The lower part of the main fairing panel will need to be loosened to allow for access to Bolt 4 in terms of its removal and replacement.
2. Remove 4 existing bolts from the stock Alternator cover, shown as position Bolt 1, 2, 3 & 4.
3. Place the Secondary Alternator Cover over the stock cover.
4. Assemble 4 replacement bolts loosely in the correct positions as shown.
5. Tighten bolts to a Torque of 11Nm as per Manufacturer's recommendations. **DO NOT OVERTIGHTEN.**
6. Replace lower belly panel.

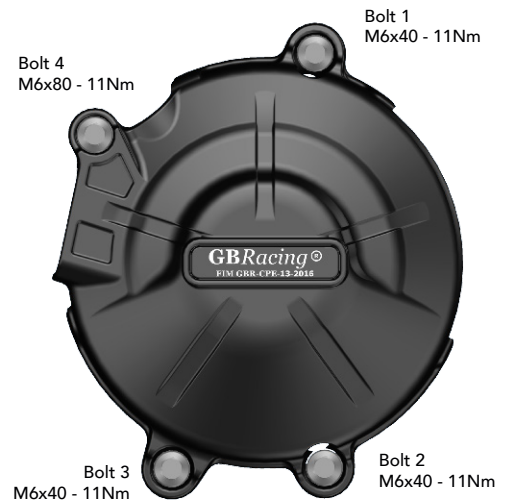
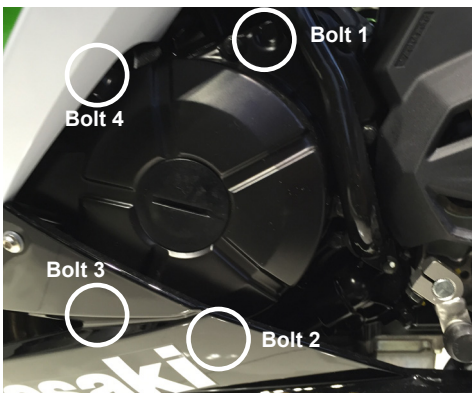

SECONDARY CLUTCH COVER
PART NO. EC-Z300-2014-2-GBR

1. Remove offside lower belly pan panel.
2. Remove 4 existing bolts from the stock Clutch cover, shown as position Bolt 1, 2, 3 & 4.
3. Place the Secondary Clutch Cover over the stock cover.
4. Assemble 4 replacement bolts loosely in the correct positions as shown.
5. Tighten bolts to a Torque of 11Nm as per Manufacturer's recommendations. **DO NOT OVERTIGHTEN.**
6. Replace lower belly pan panel.

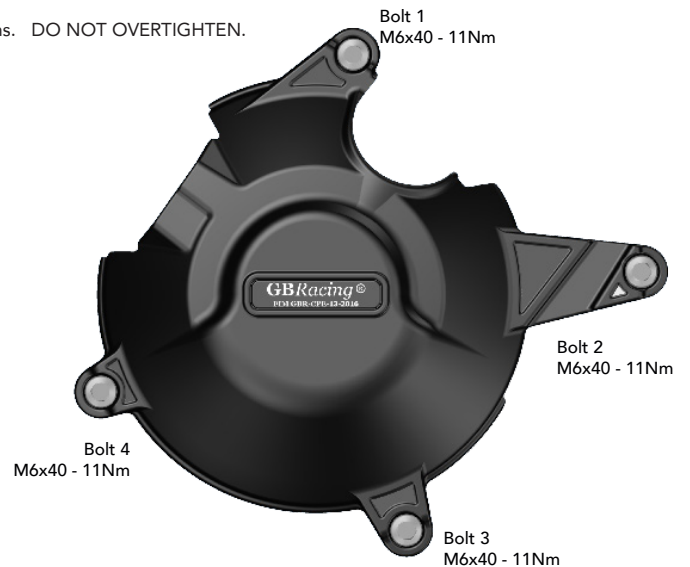
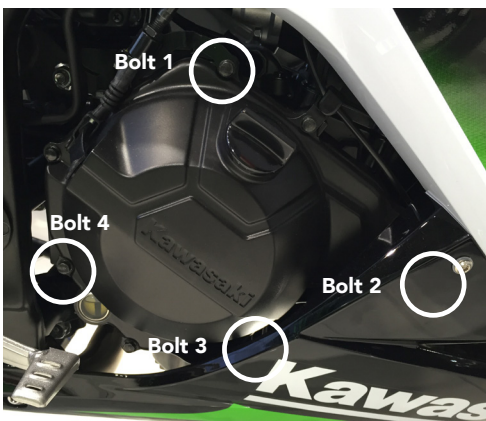

Engine Cover Set: EC-Z300-2014-SET-GBR
EC-Z300-2014-1-GBR - EC-Z300-2014-2-GBR

www.GBRacing.eu