

THIS SHEET INCLUDES FITTING INSTRUCTIONS FOR THE FOLLOWING PARTS:

Secondary Alternator Cover Part No. EC-R1-2009-1-GBR / Secondary Alternator Cover KIT Part No. EC-R1-2009-1-K-GBR /  
Secondary Clutch Cover Part No. EC-R1-2009-2-GBR / Secondary Pulse Cover Part No. EC-R1-2009-3-GBR  
Paddock Stand / Bobbin Set Part No. BA12-6-GBR-SET



**SECONDARY ALTERNATOR COVER PART NO. EC-R1-2009-1-GBR**

- 1 Remove 4 existing bolts from the stock Alternator cover, shown as position Bolt 1, 2, 3 & 4.
- 2 Place the Secondary Alternator Cover over the stock cover.
- 3 Assemble 4 replacement bolts loosely in the correct position as shown.
- 4 Tighten bolts to a Torque of 10Nm as per manufacturers recommendations.  
DO NOT OVERTIGHTEN.

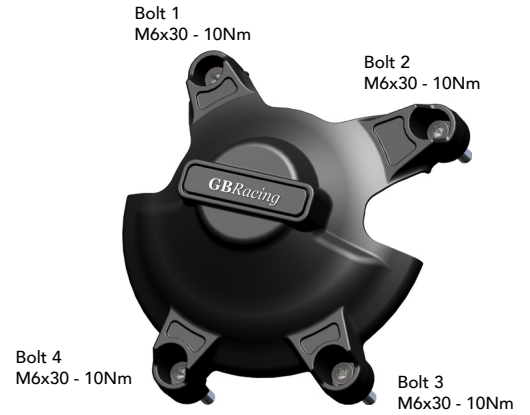
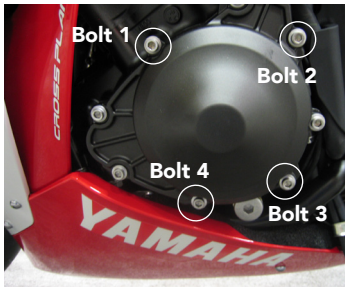

**SECONDARY CLUTCH COVER PART NO. EC-R1-2009-2-GBR**

- 1 Remove 4 existing bolts from the stock Clutch cover, shown as position Bolt 1, 2, 3 & 4.
- 2 Place the Secondary Clutch Cover over the stock cover.
- 3 Assemble 4 replacement bolts loosely in the correct position as shown.
- 4 Tighten bolts to a Torque of 10Nm as per manufacturers recommendations.  
DO NOT OVERTIGHTEN.

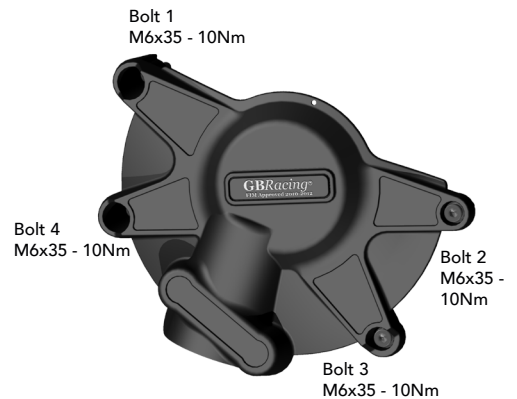
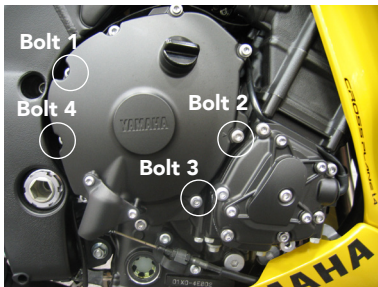

**SECONDARY PULSE COVER PART NO. EC-R1-2009-3-GBR**

- 1 Remove 3 existing bolts from the stock Pulse cover, shown as position Bolt 1, 2, & 3.
- 2 Place the Secondary Pulse Cover over the stock cover.
- 3 Assemble 3 replacement bolts loosely in the correct position as shown.
- 4 Tighten bolts to a Torque of 10Nm as per manufacturers recommendations.  
DO NOT OVERTIGHTEN.

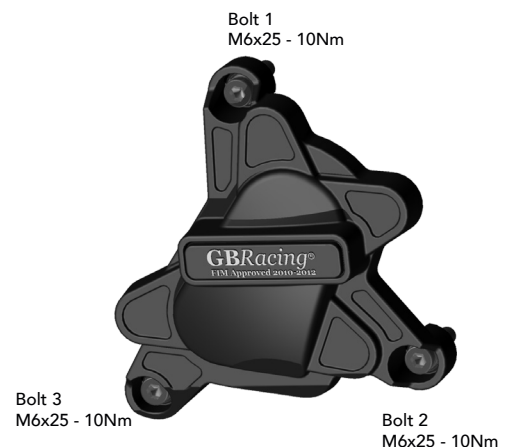
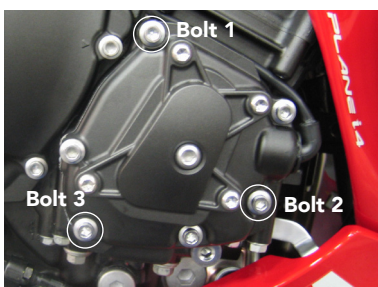

**SECONDARY ALTERNATOR COVER - KIT - PART NO. EC-R1-2009-1-K-GBR**

- 1 Remove 4 existing bolts from the stock Alternator cover, shown as position Bolt 1, 2, 3 & 4.
- 2 Place the Secondary Alternator Cover over the stock cover.
- 3 Assemble 4 replacement bolts loosely in the correct position as shown.
- 4 Tighten bolts to a Torque of 10Nm as per manufacturers recommendations.  
DO NOT OVERTIGHTEN.

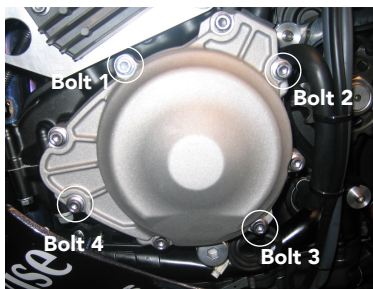

KIT ONLY

Bolt 1  
M6x30 - 10Nm

Bolt 2  
M6x30 - 10Nm

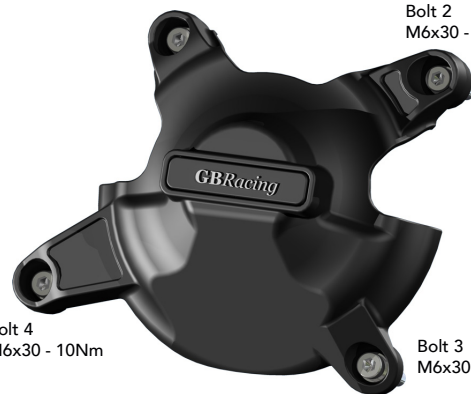

Bolt 4  
M6x30 - 10Nm

Bolt 3  
M6x30 - 10Nm

**PADDOCK STAND / BOBBIN SET**  
**PART NO. BA12-6-GBR-SET**

- 1 Assemble M6 x 40mm Bolt & M6 Washer through the moulded bobbin.
- 2 Tighten bolts to swing arm boss, 8 Nm.  
DO NOT OVERTIGHTEN

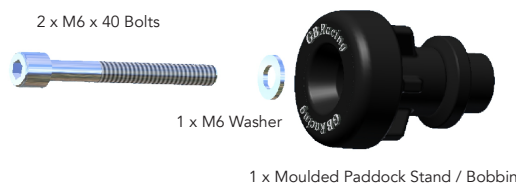

[www.GBRacing.eu](http://www.GBRacing.eu)

**SETS & BUNDLE:**

Engine Cover Set **STOCK EC-R1-2009-SET-GBR:** EC-R1-2009-1-GBR, EC-R1-2009-2-GBR, EC-R1-2009-3-GBR

Engine Cover Set **KIT EC-R1-2009-SET-K-GBR:** EC-R1-2009-1-K-GBR, EC-R1-2009-2-GBR, EC-R1-2009-3-GBR

Engine Protection Bundle **STOCK CP-R1-2009-CS-GBR:** EC-R1-2009-1-GBR, EC-R1-2009-2-GBR, EC-R1-2009-3-GBR, BA12-6-GBR-SET

Engine Protection Bundle **KIT CP-R1-2009-CS-K-GBR:** EC-R1-2009-1-K-GBR, EC-R1-2009-2-GBR, EC-R1-2009-3-GBR, BA12-6-GBR-SET