

STOCK 8mm

THIS SHEET INCLUDES FITTING INSTRUCTIONS FOR THE FOLLOWING PARTS:

Secondary STOCK Alternator Cover Part No. EC-D675R-2013-1-GBR / Secondary Clutch Cover Part No. EC-D675R-2011-2-GBR /

Secondary Pulse Cover Part No. EC-D675R-2013-3-GBR

Paddock Stand / Bobbin Set Part No. BA12-8-GBR-SET / Lower Chain Guard Part No. CGA06-GBR

Bullet Frame Slider Set RACE - D675R Model ONLY - Part No. FS-675-2013-R



SECONDARY ALTERNATOR COVER - STOCK - PART NO. EC-D675R-2013-1-GBR

- 1 Remove lower fairing.
- 2 Remove 4 existing bolts from the stock Alternator cover, shown as position Bolt 1, 2, 3 & 4.
- 3 Place the Secondary Alternator Cover over the stock cover.
- 4 Assemble 4 replacement bolts loosely in the correct position as shown.
- 5 Tighten bolts to a Torque of 8 Nm as per manufacturers recommendations. DO NOT OVERTIGHTEN.
- 6 Re-Fit lower Fairing.

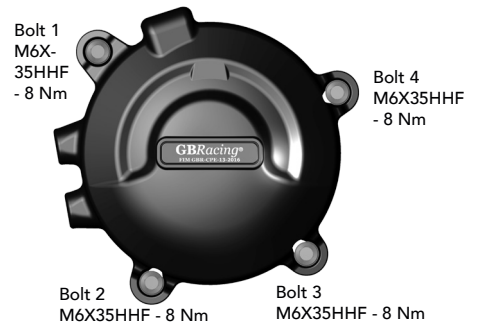

SECONDARY CLUTCH COVER PART NO. EC-D675R-2011-2-GBR

- 1 Remove lower fairing.
- 2 Remove 4 existing bolts from the stock Clutch cover, shown as position Bolt 1, 2, 3 & 4.
- 3 Place the Secondary Clutch Cover over the stock cover.
- 4 Assemble 4 replacement bolts loosely in the correct position as shown.
- 5 Tighten bolts to a Torque of 8 Nm as per Manufacturer's recommendations. DO NOT OVERTIGHTEN.
- 6 Re-Fit lower Fairing.

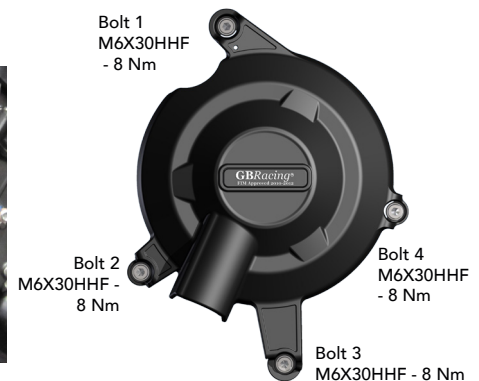
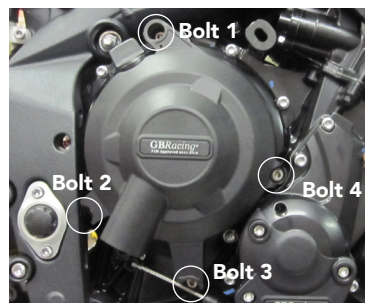

SECONDARY PULSE COVER PART NO. EC-D675R-2013-3-GBR

- 1 Remove lower fairing.
- 2 Remove 4 existing bolts from the stock Pulse cover, shown as position Bolt 1, 2, 3 & 4.
- 3 Place the Secondary Pulse Cover over the stock cover.
- 4 Assemble 4 replacement bolts loosely in the correct position as shown.
- 5 Tighten bolts to a Torque of 8 Nm as per Manufacturer's recommendations. DO NOT OVERTIGHTEN.

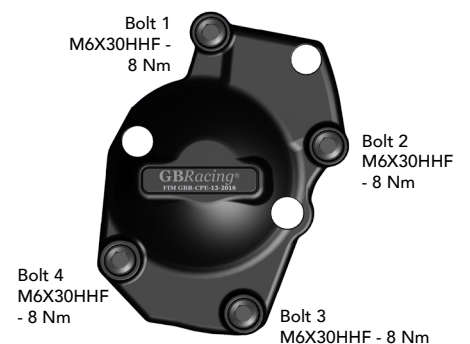
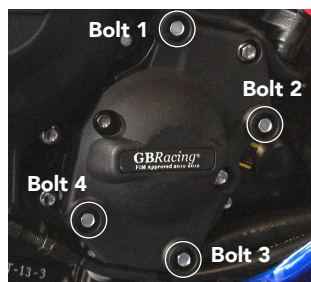

LOWER CHAIN GUARD PART NO. CGA06-GBR

- 1 Assemble 2 off M6 washers on to 2 off M6 x 20mm Bolts
- 2 Line up the Moulded Chain Guard to the Swing Arm bosses.
- 3 Assemble the M6 bolts through the 2 fixing holes on the aligned chain guard.
- 4 Assemble remaining 2 off M6 washers & M6 Lock Nuts onto the M6 bolts. DO NOT OVERTIGHTEN.



STOCK 8mmBullet Frame Slider Set - RACE - **D675R 2013-2016 Model ONLY** - Part No. FS-675-2013-R**BULLET FRAME SLIDER SET - LEFT HAND SIDE - RACE**

- 1 Remove front fairing.
- 2 Remove front engine mount bolt.
- 3 Assemble bolt through the aluminium bush into correct position.
- 4 Tighten to 25NM torque.
- 5 Slide bullet moulding onto aluminium bush.
- 6 Screw M6 bolt into front of bullet moulding hand tight.
- 7 Replace fairing.

**BULLET FRAME SLIDER SET - LEFT HAND SIDE - RACE**

- 1 Remove front fairing.
- 2 Remove front engine mount bolt.
- 3 Assemble bolt through the aluminium bush into correct position.
- 4 Tighten to 25NM torque.
- 5 Slide bullet moulding onto aluminium bush.
- 6 Screw M6 bolt into front of bullet moulding hand tight.
- 7 Replace fairing.

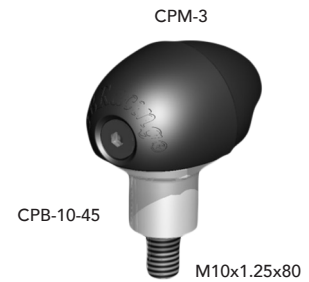
www.GBRacing.eu**Engine Cover Set: EC-D675R-2013-SET-GBR**

EC-D675R-2013-1-GBR, EC-D675R-2011-2-GBR, EC-D675R-2013-3-GBR