

### STOCK 8mm

THIS SHEET INCLUDES FITTING INSTRUCTIONS FOR THE FOLLOWING PARTS:

Secondary STOCK Alternator Cover Part No. EC-D675R-2011-1-GBR / Secondary Clutch Cover Part No. EC-D675R-2011-2-GBR /  
Secondary Pulse Cover Part No. EC-D675R-3-GBR  
Bullet Frame Race Slider Set - STREET - Part No. FS-675-2006-CS-S / Bobbin Set Part No. BA12-8-GBR-SET /  
Lower Chain Guard Part No. CGA06-GBR / Front Spindle Protectors Part No. BA-675-SET-GBR



#### SECONDARY ALTERNATOR COVER - **STOCK** - PART NO. EC-D675R-2011-1-GBR

- 1 Remove lower fairing.
- 2 Remove 4 existing bolts from the stock Alternator cover, shown as position Bolt 1, 2, 3 & 4.
- 3 Place the Secondary Alternator Cover over the stock cover.
- 4 Assemble 4 replacement bolts loosely in the correct position as shown.
- 5 Tighten bolts to a Torque of 8 Nm as per manufacturer's recommendations. DO NOT OVERTIGHTEN.
- 6 Re-Fit lower Fairing.

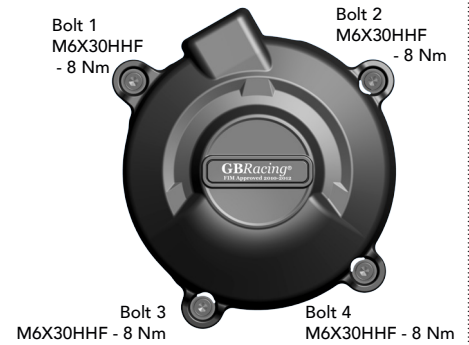
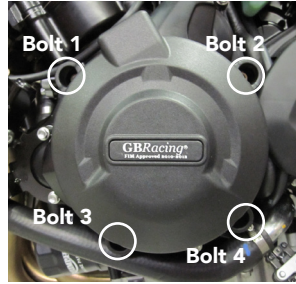

#### SECONDARY CLUTCH COVER PART NO. EC-D675R-2011-2-GBR

- 1 Remove lower fairing.
- 2 Remove 4 existing bolts from the stock Clutch cover, shown as position Bolt 1, 2, 3 & 4.
- 3 Place the Secondary Clutch Cover over the stock cover.
- 4 Assemble 4 replacement bolts loosely in the correct position as shown.
- 5 Tighten bolts to a Torque of 8 Nm as per manufacturer's recommendations. DO NOT OVERTIGHTEN.
- 6 Re-Fit lower Fairing.

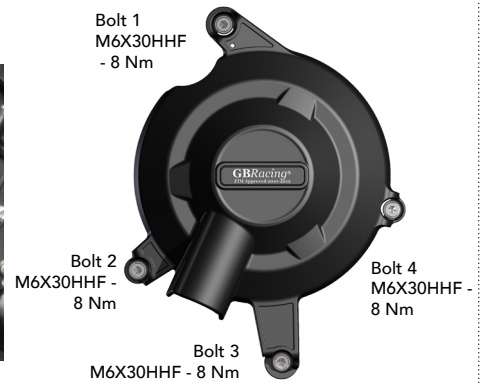
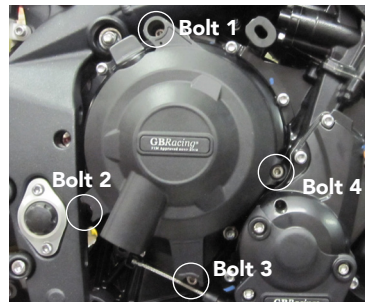

#### SECONDARY PULSE COVER PART NO. EC-D675-3-GBR

- 1 Remove 4 off existing Bolts at the base of the stock aluminium Pulse cover.
- 2 Place the Secondary Pulse Cover over the stock aluminium Pulse cover.
- 3 Loosely assemble the top 2 M6x30 Bolts 1&2 then assemble the bottom 2 M6x25 Bolts 3&4.
- 4 Tighten all 4 bolts to a torque of 8 N/m as per manufacturer's recommendations. DO NOT OVERTIGHTEN

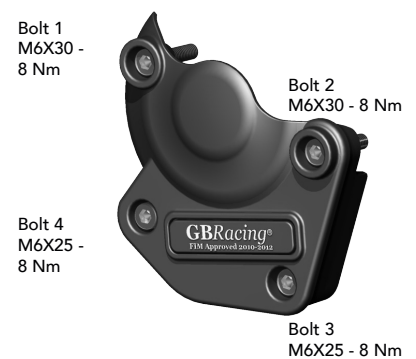
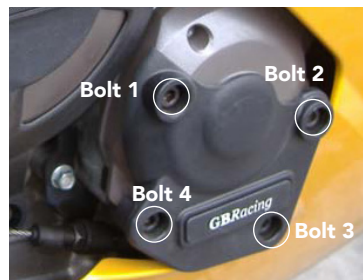

#### LOWER CHAIN GUARD PART NO. CGA06-GBR

- 1 Assemble 2 off M6 washers on to 2 off M6 x 20mm Bolts
- 2 Line up the Moulded Chain Guard to the Swing Arm bosses.
- 3 Assemble the M6 bolts through the 2 fixing holes on the aligned chain guard.
- 4 Assemble remaining 2 off M6 washers & M6 Lock Nuts onto the M6 bolts. DO NOT OVERTIGHTEN.



**STOCK 8mm**

**BULLET FRAME SLIDER - LEFT HAND SIDE - STREET**

**PART NO. FS-675-2006-LHS-SET-S**

1. Remove left side fairing
  2. Unscrew engine bolts 1 & 2 as shown. Retain M10 locking nuts from Bolt 1.
  3. Assemble black anodised bracket. Use 1 off M10 x 120 x 1.25 & 1 off M10 x 60 x 1.25 nickel plated bolts. Re-use the original M10 locking nut.
- Note: You may need to loosen the Air Breather Bottle temporarily.
4. Tighten both bolts to 48 N/m, as per manufacturers recommendations.
  5. Re-assemble Left side fairing
  6. Assemble Crash Mushroom FS-675-2006-LHS-S. Tighten to 25 N/m DO NOT OVERTIGHTEN

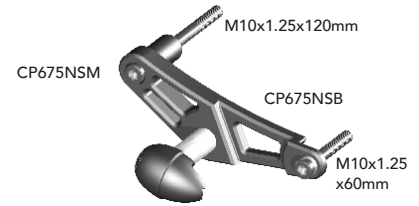
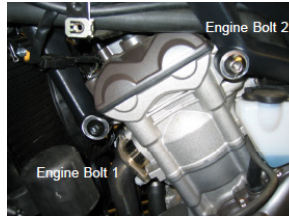

**BULLET FRAME SLIDER - RIGHT HAND SIDE - STREET**

**PART NO. FS-675-2006-RHS-SET-S**

1. Remove right side fairing
  2. Unscrew engine bolts 1 & 2 as shown. Retain M10 locking nuts from Bolt 1.
  3. Assemble black anodised bracket. Use 1 off M10 x 120 x 1.25 & 1 off M10 x 60 x 1.25 nickel plated bolts. Re-use the original M10 locking nut.
- Note: You may need to loosen the Air Breather Bottle temporarily.
4. Tighten both bolts to 48 N/m, as per manufacturers recommendations.
  5. Re-assemble Right side fairing
  6. Assemble Crash Mushroom FS-675-2006-LHS-S. Tighten to 25 N/m. DO NOT OVERTIGHTEN

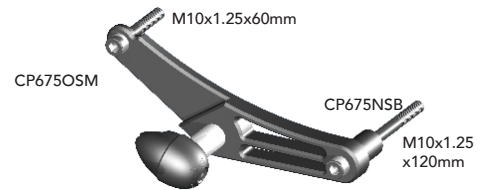
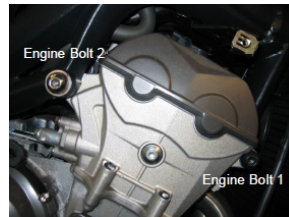

**FRONT SPINDLE PROTECTORS - LEFT HAND SIDE**

**PART NO. BA-675-LHS-GBR**

- 1 Assemble the Stainless Steel bar through the front spindle.
  - 2 Place the Left Hand Side spindle protector assembly over the bar.
  - 3 Assemble the M6 Washer first, then the lock nut. (The Washer must be used).
- Note: You can prevent the bar from rotating by holding the opposite end of the bar by the slot providing with a flat headed screw driver.
- 4 When both ends are fitted, tighten the lock nuts together to a Torque of 10Nm. There should be approximately 2-3 threads equally showing over the lock nuts. DO NOT OVERTIGHTEN.

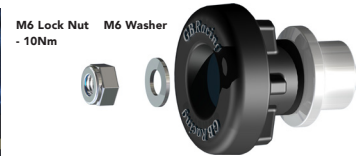

**FRONT SPINDLE PROTECTORS - LEFT HAND SIDE**

**PART NO. BA-675-LHS-GBR**

- 1 Assemble the Stainless Steel bar through the front spindle.
  - 2 Place the Right Hand Side spindle protector assembly over the bar.
  - 3 Assemble the M6 Washer first, then the lock nut. (The Washer must be used).
- Note: You can prevent the bar from rotating by holding the opposite end of the bar by the slot providing with a flat headed screw driver.
- 4 When both ends are fitted, tighten the lock nuts together to a Torque of 10Nm. There should be approximately 2-3 threads equally showing over the lock nuts. DO NOT OVERTIGHTEN.

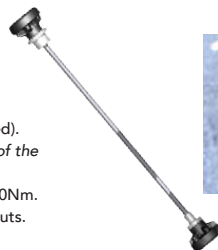

**PADDOCK STAND / BOBBIN SET**

**PART NO. BA12-8-GBR-SET**

- 1 Assemble M8 x 40mm Bolt through the moulded bobbin.
  - 2 Tighten bolts to swing arm boss, 8 Nm.
- DO NOT OVERTIGHTEN



1 x Moulded Paddock Stand / Bobbin

[www.GBRacing.eu](http://www.GBRacing.eu)

**Protection Bundle: CP-D675R-2011-CS-8-GBR**

EC-D675R-2011-1-GBR, EC-D675R-2011-2-GBR, EC-D675-3-GBR, CGA06-GBR, BA-675-SET-GBR, BA12-8-GBR-SET, FS-675-2006-CS-S

**Engine Cover Set: EC-D675R-2011-SET-GBR**

EC-D675R-2011-1-GBR, EC-D675R-2011-2-GBR, EC-D675-3-GBR

DO NOT use these products unless you agree to our Terms & Conditions, as shown on our paperwork and website. If you do not agree, please return the product(s) to your dealer for a refund.