

THIS SHEET INCLUDES FITTING INSTRUCTIONS FOR THE FOLLOWING PARTS:

Secondary Alternator Cover Part No. EC-R1-2015-1-GBR / Secondary Clutch Cover Part No. EC-R1-2015-2-GBR /
Secondary Pulse Cover Part No. EC-R1-2015-3-GBR

Bullet Frame Race Slider Set - STREET - Part No. FS-R1-2015-S / Bullet Frame Race Slider Set - RACE - Part No. FS-R1-2015-R /
Yamaha 6mm Paddock Stand / Bobbin Set Part No. BA12-6-GBR-SET / Lower Chain Guard Part No. CGA10-GBR



SECONDARY ALTERNATOR COVER
PART NO. EC-R1-2015-1-GBR

1. Remove 4 existing bolts from the stock Alternator cover, shown as position Bolt 1, 2, 3 & 4.
2. Place the Secondary Alternator Cover over the stock cover.
3. Assemble 4 replacement bolts loosely in the correct position as shown.
4. Tighten bolts to a Torque of 6Nm. DO NOT OVERTIGHTEN.

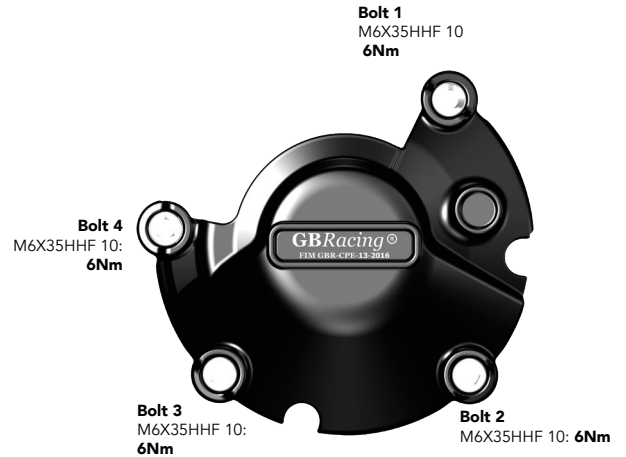
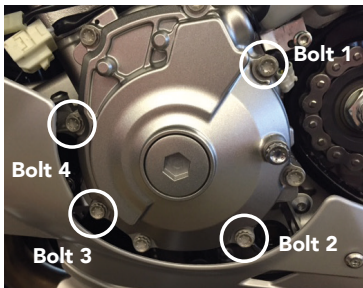

SECONDARY CLUTCH COVER
PART NO. EC-R1-2015-2-GBR

1. Remove 4 existing bolts from the stock Clutch cover, shown as position Bolt 1, 2, 3 & 4.
2. Place the Secondary Clutch Cover over the stock cover.
3. Assemble 4 replacement bolts loosely in the correct positions as shown.
4. Tighten bolts to a Torque of 6Nm. DO NOT OVERTIGHTEN.

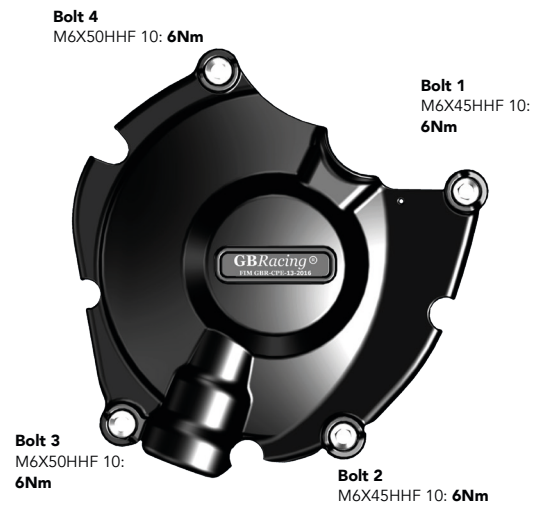
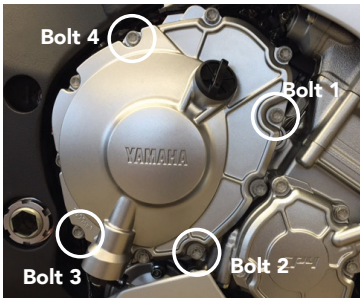

SECONDARY PULSE COVER
PART NO. EC-R1-2015-3-GBR

1. Remove 3 existing bolts from the stock pulse cover, shown as position Bolt 1, 2 & 3.
2. Place the Secondary Pulse Cover over the stock cover.
3. Assemble 3 replacement bolts loosely in the correct positions as shown.
4. Tighten bolts to a Torque of 6Nm. DO NOT OVERTIGHTEN.

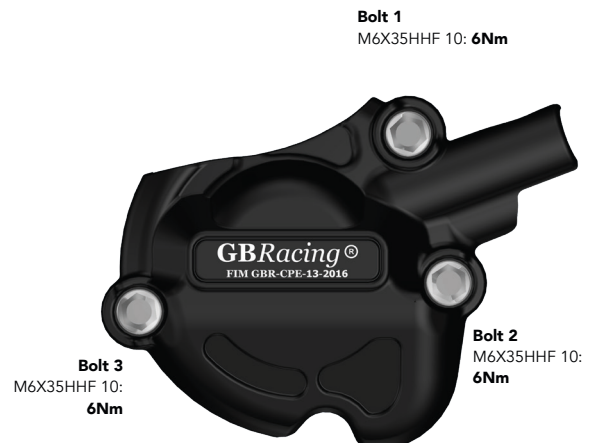
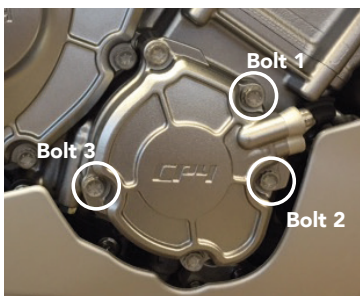

BULLET FRAME SLIDER - LEFT HAND SIDE - STREET
PART NO. FS-R1-2015-LHS-S

- 1 Remove upper engine mounting bolt, located through the fairing opening.
- 2 Assemble bolt through the aluminium bush into correct position.
- 3 Tighten to 70NM torque.
- 4 Slide bullet moulding onto aluminium bush.
- 5 Screw M6 bolt into front of bullet moulding hand tight.

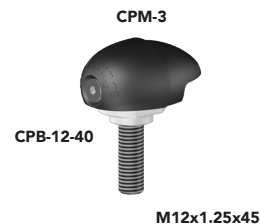

BULLET FRAME SLIDER - RIGHT HAND SIDE - STREET
PART NO. FS-R1-2015-RHS-S

- 1 Remove upper engine mounting bolt, located through the fairing opening.
(ensuring that the OE Washer is not removed).
- 2 Assemble bolt through the aluminium bush into correct position.
- 3 Tighten to 70NM torque.
- 4 Slide bullet moulding onto aluminium bush.
- 5 Screw M6 bolt into front of bullet moulding hand tight.



BULLET FRAME SLIDER - LEFT HAND SIDE - RACE
PART NO. FS-R1-2015-LHS-R

- 1 Remove upper fairing.
- 2 Remove upper engine mounting bolt. Fairing will require modification as per image to allow the frame slider to protrude slightly.
- 3 Assemble bolt through the aluminium bush into correct position.
- 4 Tighten to 70NM torque.
- 5 Slide bullet moulding onto aluminium bush.
- 6 Screw M6 bolt into front of bullet moulding hand tight.
- 7 Replace upper fairing.



BULLET FRAME SLIDER - RIGHT HAND SIDE - RACE
PART NO. FS-R1-2015-RHS-R

- 1 Remove upper engine mounting bolt, located through the fairing opening.
- 2 Assemble bolt through the aluminium bush into correct position.
- 3 Tighten to 70NM torque.
- 4 Slide bullet moulding onto aluminium bush.
- 5 Screw M6 bolt into front of bullet moulding hand tight.



PADDOCK STAND / BOBBIN SET
PART NO. BA12-6-GBR-SET

- 1 Assemble M6 x 40mm Bolt & M6 Washer through the moulded bobbin.
- 2 Tighten bolts to swing arm boss, 8 Nm.
DO NOT OVERTIGHTEN

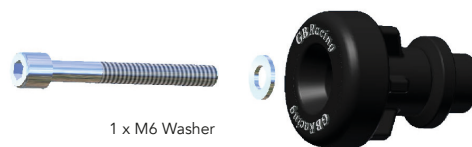

1 x Moulded Paddock Stand / Bobbin

LOWER CHAIN GUARD
PART NO. CGA10-GBR

- 1 Assemble 2 bolts and washers through the lower chain guard into the Black Anodised aluminium mounting block CGA10-2.
- 2 Position the assembly underneath the swing arm, closing the gap to the rear sprocket.
Note : There should be a 5mm minimum gap from the bike chain to the lower chain guard.
- 3 Mark off the chosen hole positions.
- 4 Drill & Tap the marked holes , M6 - (Drill 5mm Dia. for tapping)
- 5 Disassemble the Black Anodised block from the assembly, and mount the block to the underside of the swing arm using the remaining 2 bolts and washers.
- 6 Re-assemble the lower chain guard to the fixed bracket.

