

21055 Honda CB750 Hornet Radiator Cheeks 2023> Fitting Instructions

Kit Includes:

1.	X1	21055A	Hornet Radiator Cheek (LHS)
2.	X1	21055B	Hornet Radiator Cheek (RHS)
3.	X1	CFK21055A	Carbon Steel Bracket (LHS)
4.	X1	CFK21055B	Carbon Steel Bracket (RHS)
5.	X2	CBOLM50008	M5x16mm Flanged-Button Bolt
6.	X2	CBOLM60012	M6x30mm Flanged-Button Bolt
7.	X2	CBOLM60007	M6x12mm Flanged-Button Bolt
8.	X2	CNUTM60002	M6 Serrated-Flanged Hex Nut
9.	X4	CCAP0002	M6 Bolt Cap
10.	X2	CSPAM60022	M6x12mm Black Nylon Spacer
11.	X2	CFOA0001	2mm Foam Pad (40mm Lengths)
12.	X1	CBRA0103	Red Decal Set (21055C & 21055E)
13.	X1	CBRA0104	Black & Yellow Decal Set (21055D)
14.	X1	CBRA0105	Black Decal Set (21055Y)

The installation process is replicated on both sides. This consists of the relevant panel and fixing bracket, together with an equal share of the supplied fixings. Please note: LHS denotes the left-hand side from the rider's point of view and likewise RHS denotes the right-hand side.

Assembly Instructions

- Begin by placing the foam pad strip (Item 11) on the LHS bracket (Item 3) in the position marked in 'FIG. 3'. Please ensure the foam pad is lightly placed on the bracket in case it needs to be repositioned or trimmed.
- Continue by removing the two OEM fixings in the marked areas shown in 'FIG. 4' from the LHS of the motorcycle. Take the LHS bracket (Item 3), together with 1 x M5x16mm Bolt (Item 5), and thread the bolt into the marked area '1' shown in 'FIG. 4'. Tighten the bolt so that the bracket is parallel with the face of the radiator cheek on the motorcycle. Please do not overtighten the bolt as you may wish to adjust this angle slightly to improve the fitment of the Pyramid Radiator Cheek.
- Take the LHS Radiator Cheek (Item 1), along with 1 x M6x30mm bolt (Item 6) and 1 x black nylon spacer (Item 10). Place the spacer on the underside of the lower mounting point of the panel and thread the M6 bolt through and into the area marked '2' shown in 'FIG. 3'. Please do not tighten at this stage.
- Proceed by taking 1 x M6x12mm bolt (Item 7) and 1 x M6 nut (Item 8) and placing through the upper mounting hole of the panel to secure the bracket. Please check the alignment of the Radiator Cheek and make any adjustments by altering the angle of the bracket. Please check the support provided by the foam pad by gently pressing in that area. Make any necessary adjustments. Once you are happy with the fitment, firmly press the foam pad and tighten all fixings to sufficient resistance.
- Finally, place 2 x bolt end caps (Item 9) over the bolt heads. Repeat this step for the RHS of the motorcycle.

Please Note:

We advise that all fixings are checked periodically.

FIG. 1



Any questions?
sales@pyramidmoto.co.uk
 +44 (0)1427 677990
www.pyramidmoto.co.uk



Follow us on social media and feel free to leave us a review!

21055 Honda CB750 Hornet Radiator Cheeks 2023> Fitting Instructions

Please note: 2 x Item 9 shown in 'FIG. 2' is not required with colour options 'Pearl Glare White' or 'Goldfinch Yellow' but may be used if desired.

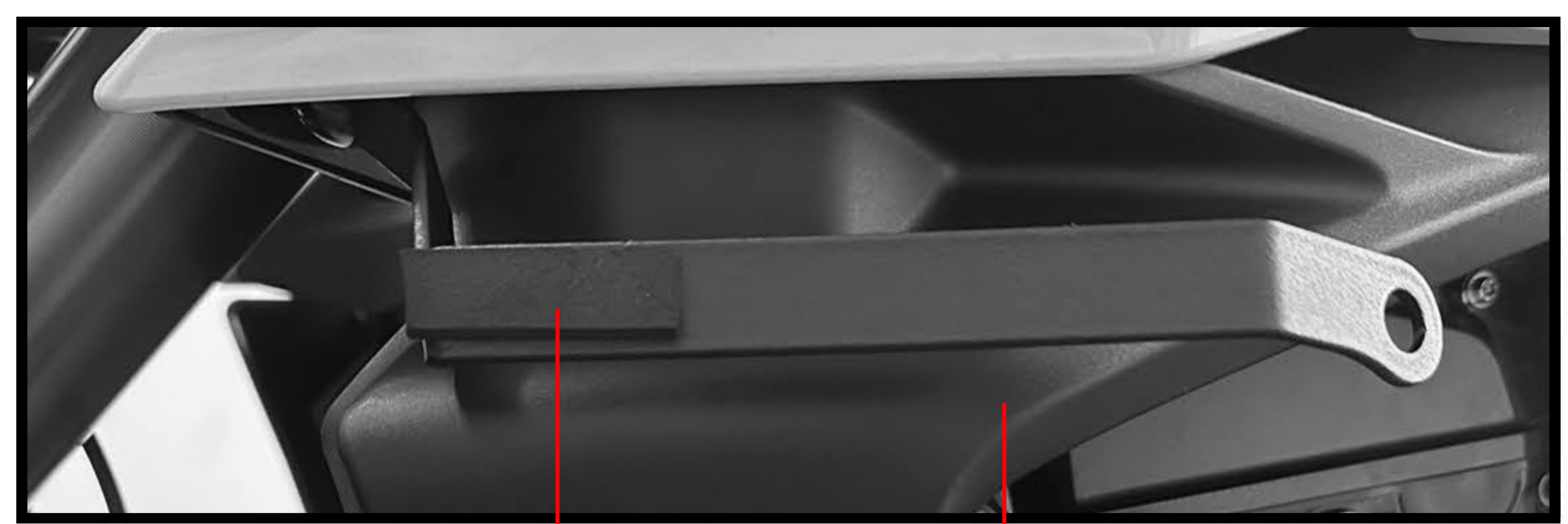
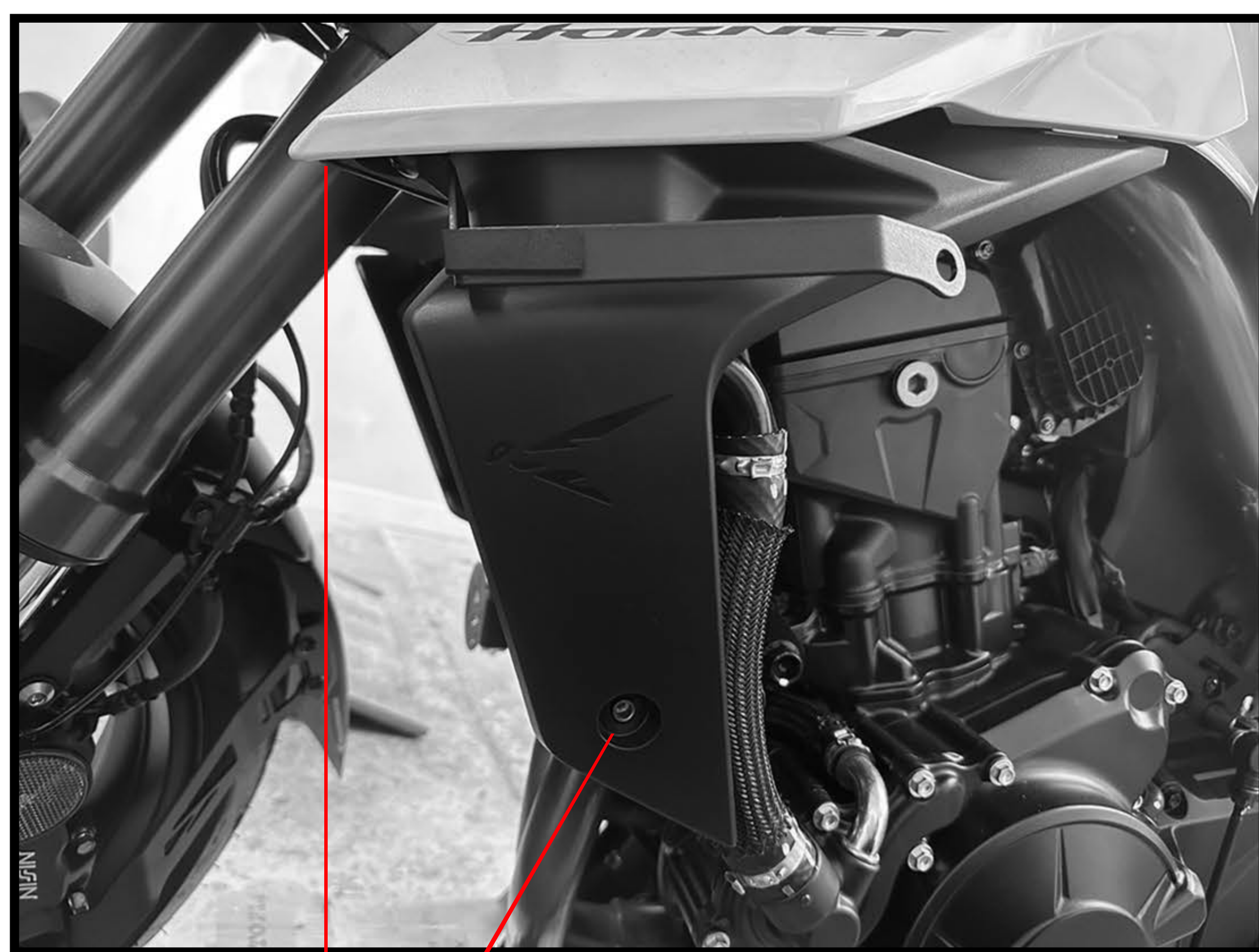
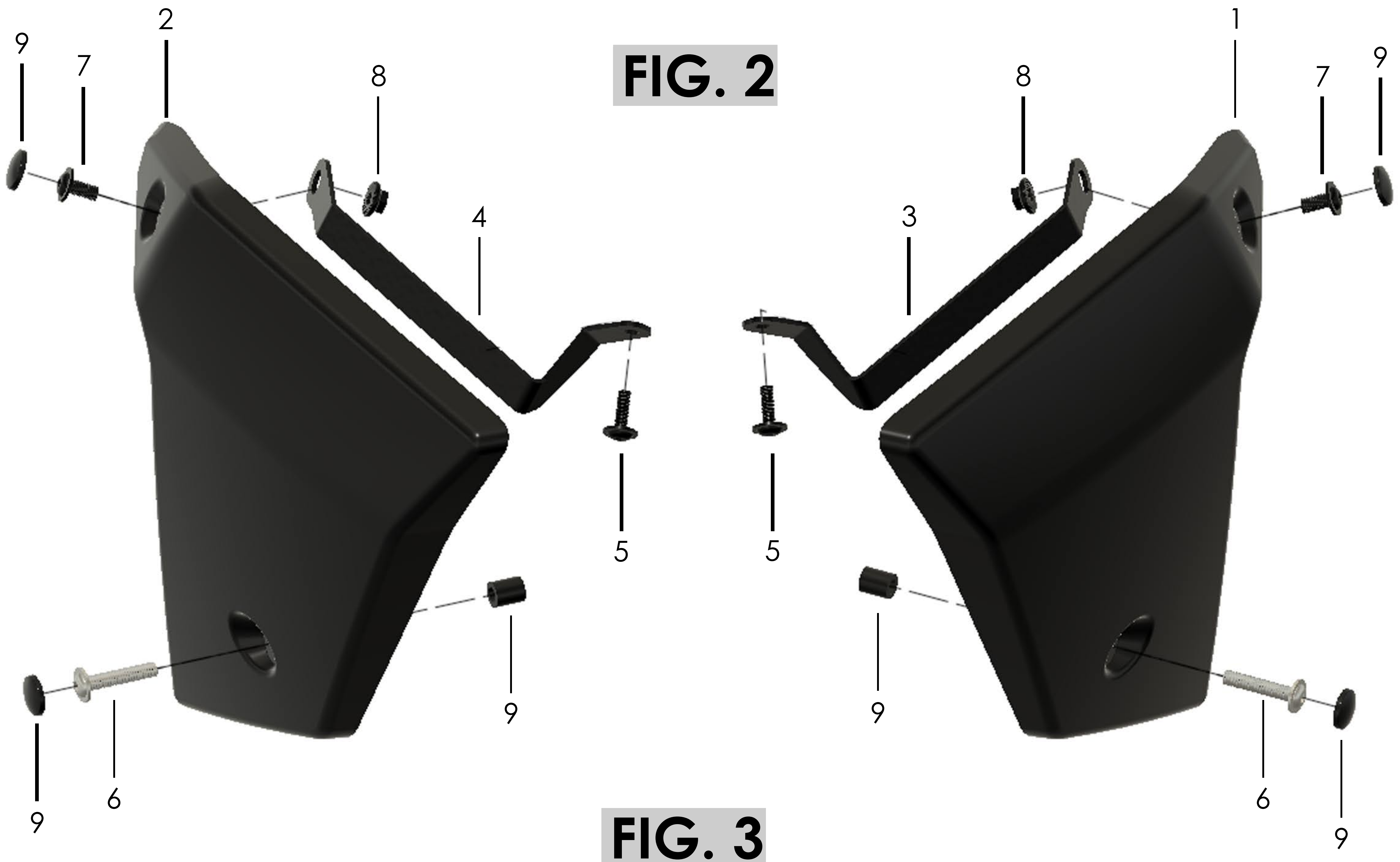

Foam pad strip placed up to the bend in the supporting bracket. Replacement or trimming may be required.

Alignment of bracket to be parallel in relation to the motorcycle. This angle may need to be altered upon fitment of the Radiator Cheek.

1 2

'FIG. 4' illustrates how to alter the angle of the bracket without having to remove the Radiator Cheek. Please ensure the bolt in the lower mounting position has been sufficiently loosened before attempting to rotate the Radiator Cheek.



FIG. 4

Any questions?
sales@pyramidmoto.co.uk
 +44 (0)1427 677990
www.pyramidmoto.co.uk



Follow us on social media and feel free to leave us a review!