

072453 Yamaha Tracer 9 Hugger Fitting Instructions

Kit Includes:

1X	C072453	Moulding
1X	CFK072453	Bracket - left-hand side front
1X	CFK072453B	Bracket - right-hand side
1X	CFK072453C	Bracket -left hand side rear
1X	CBOLM60007	M6 x 12mm Bolt
4X	CWASM60003	M6 Washer
1X	CNUTM60003	M6 Nyloc Nut
2X	CBOLM50005	M5 x 12mm Bolt
2X	CWASM50001	M5 Washer
2X	CNUTM50002	M5 Nyloc Nut
1X	CBOLM40004	M4 x 16mm Bolt
1X	CNUTM40001	M4 Rubber Anchor Nut
1X	CWASM60007	Rubber Washer

Note for GT owners: the suspension sensor mounted on top of the swingarm can be removed and refitted in its original place with our hugger without the need for modification or recalibration.

Fitting note: attach fixings loosely at first - this aids alignment of the hole centres.

Remove the left-hand side rider foot peg for access. Remove the OEM hugger from the motorcycle. Ensure all the fixings from the OEM hugger are retained. The small silver collars removed with the OEM hugger will no longer be required.

Attach the left-hand side rear bracket as shown in **Fig 1** (**Note: Do not overtighten!** Bring the components together and engage the nylon thread).

Loosely attach the left-hand side front bracket as shown in **Fig 2**.

Attach the right-hand side bracket as shown in **Fig 3** (first insert the M4 rubber anchor nut into the blank hole in the swingarm).

Position the Pyramid hugger over the rear tyre and attach as shown in **Figs 4, 5 & 6**.

Fully tighten all mounting points. Ensure fixings are checked periodically.

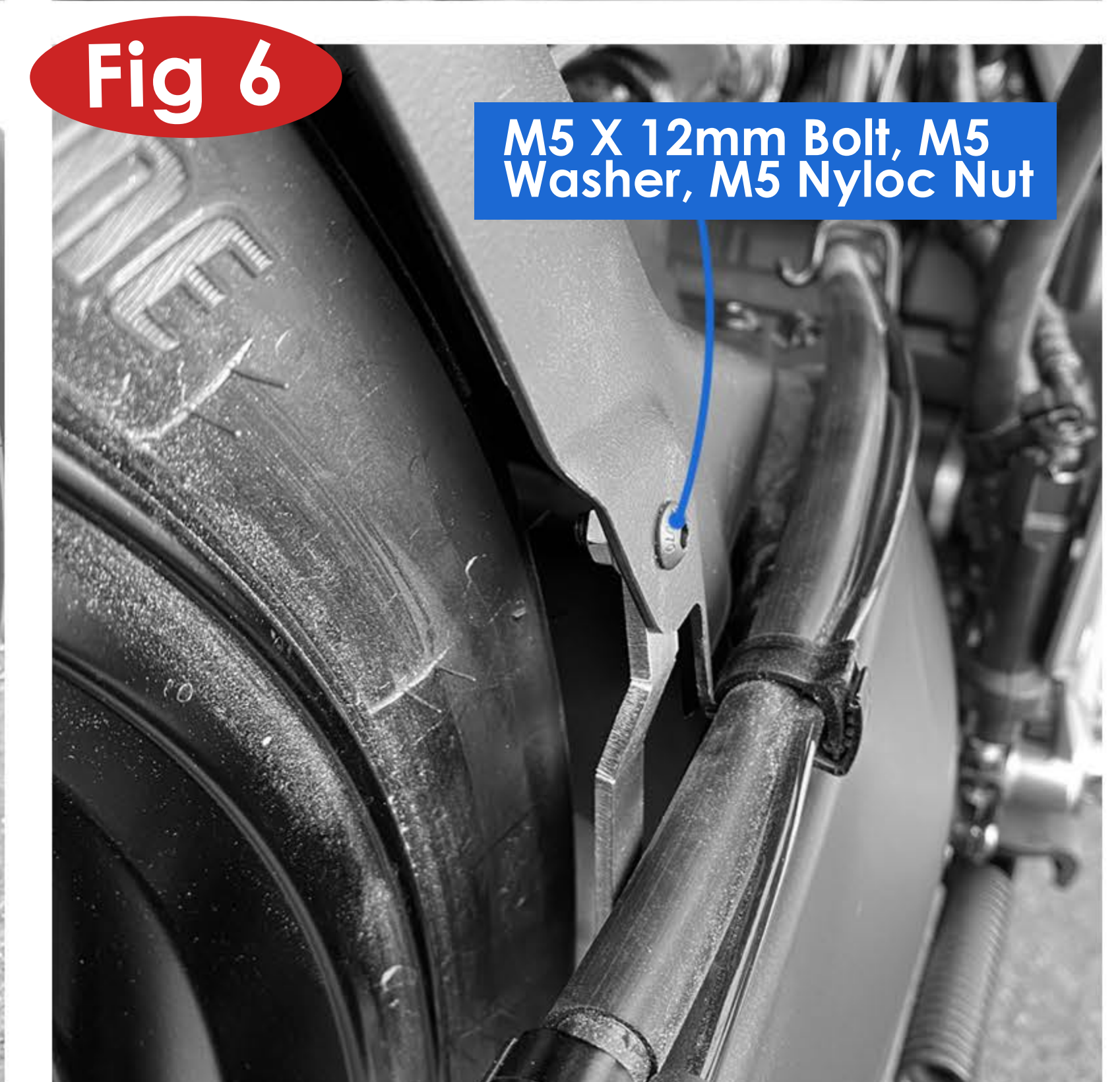
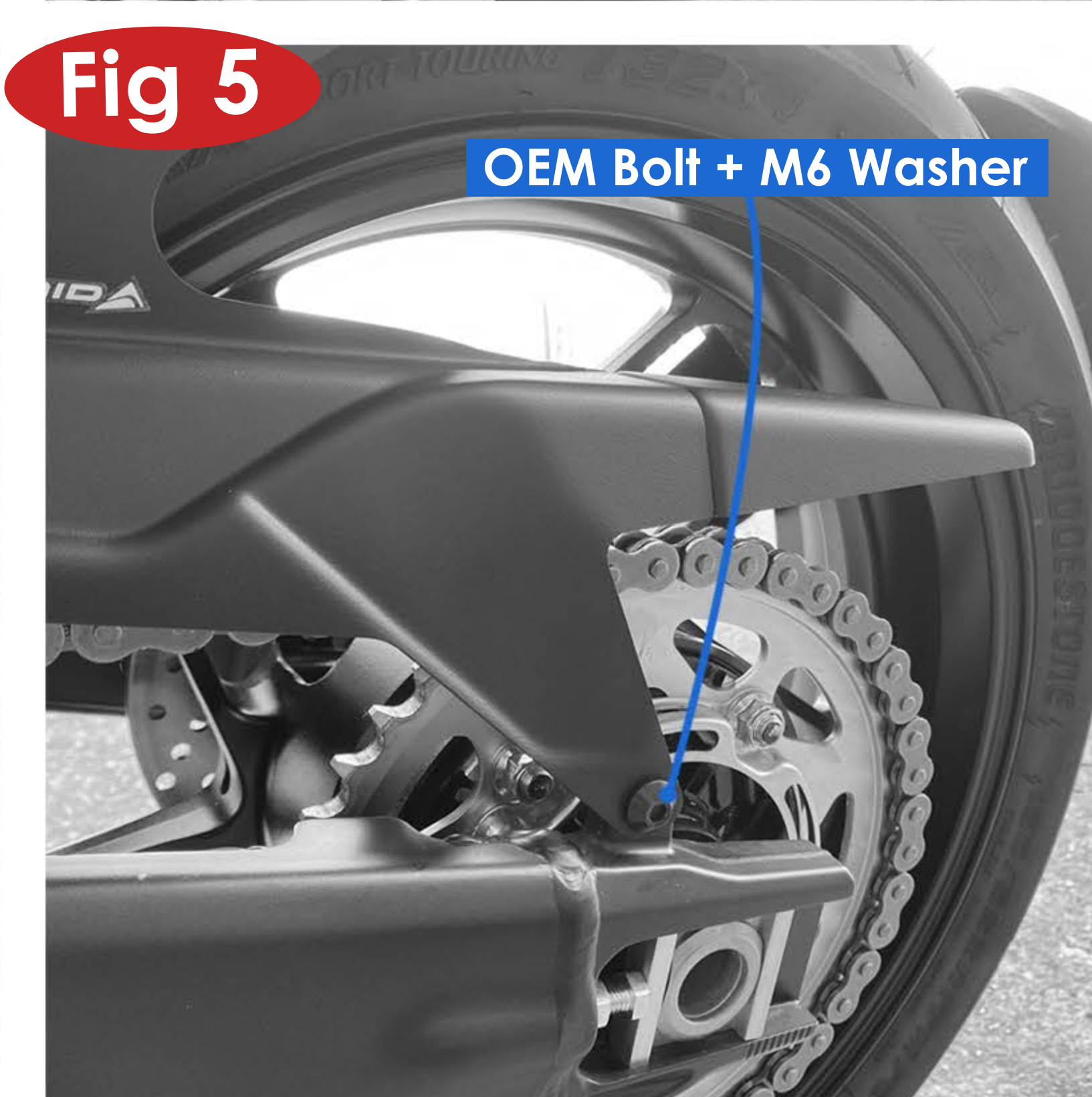
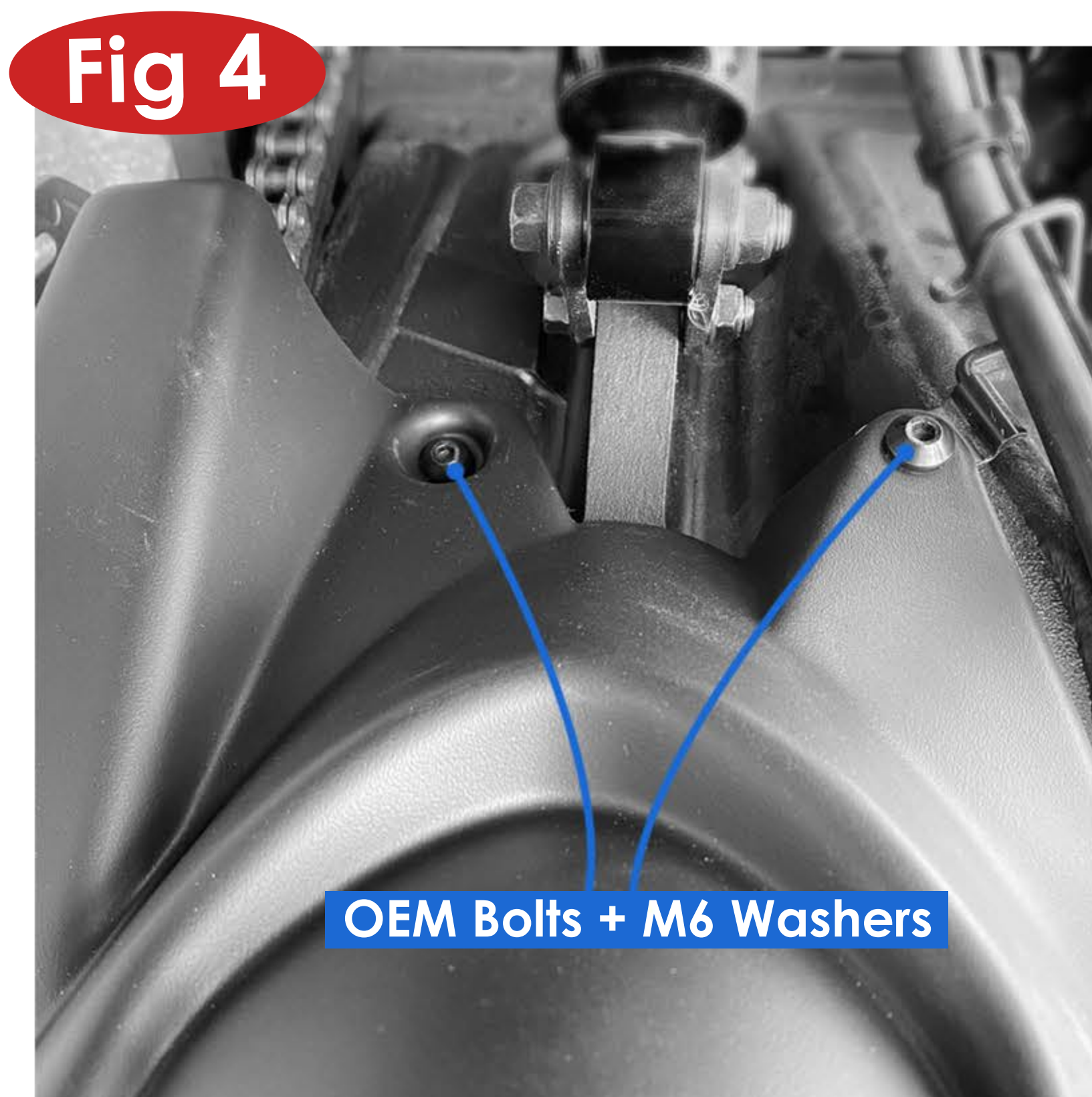
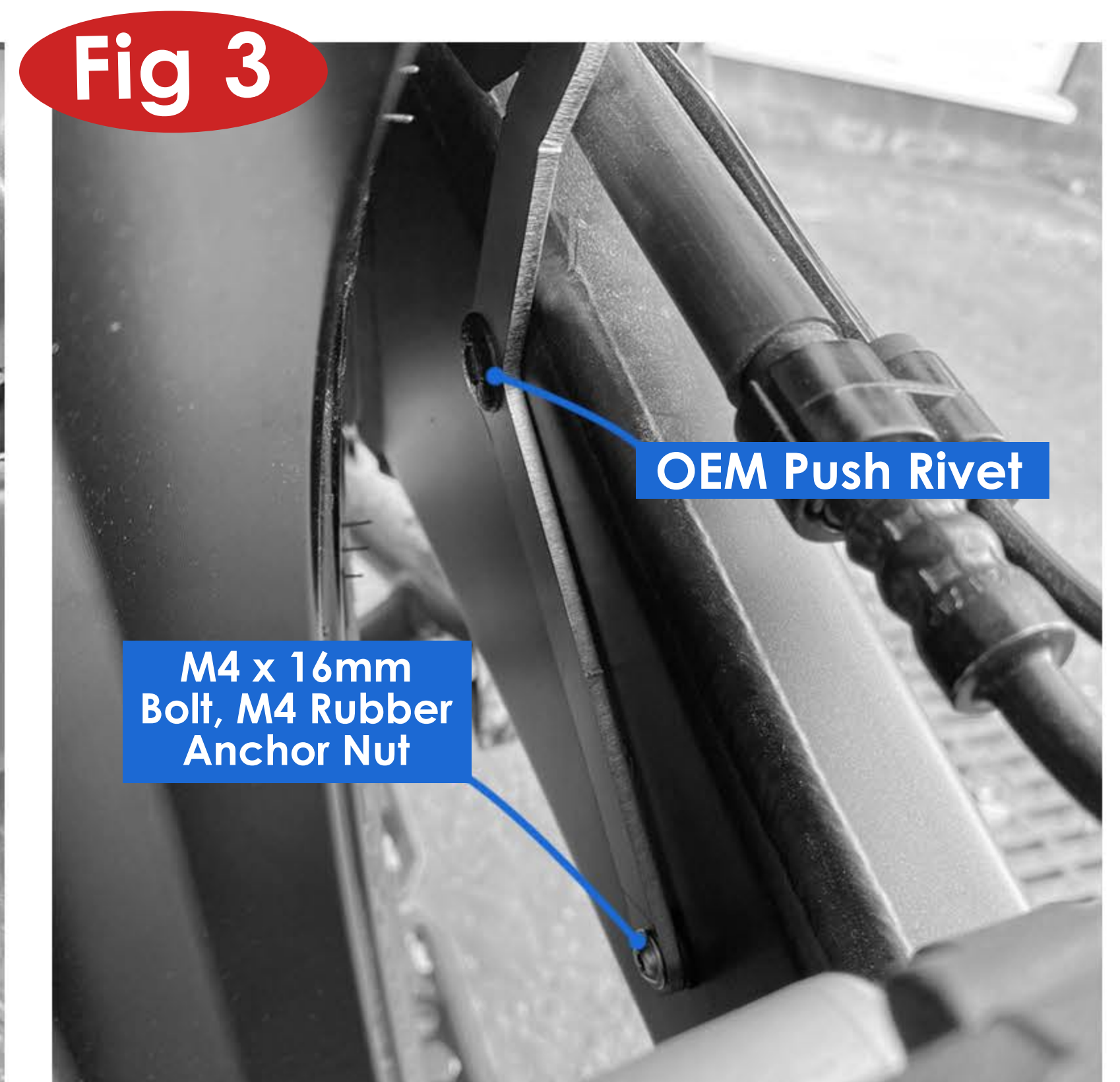
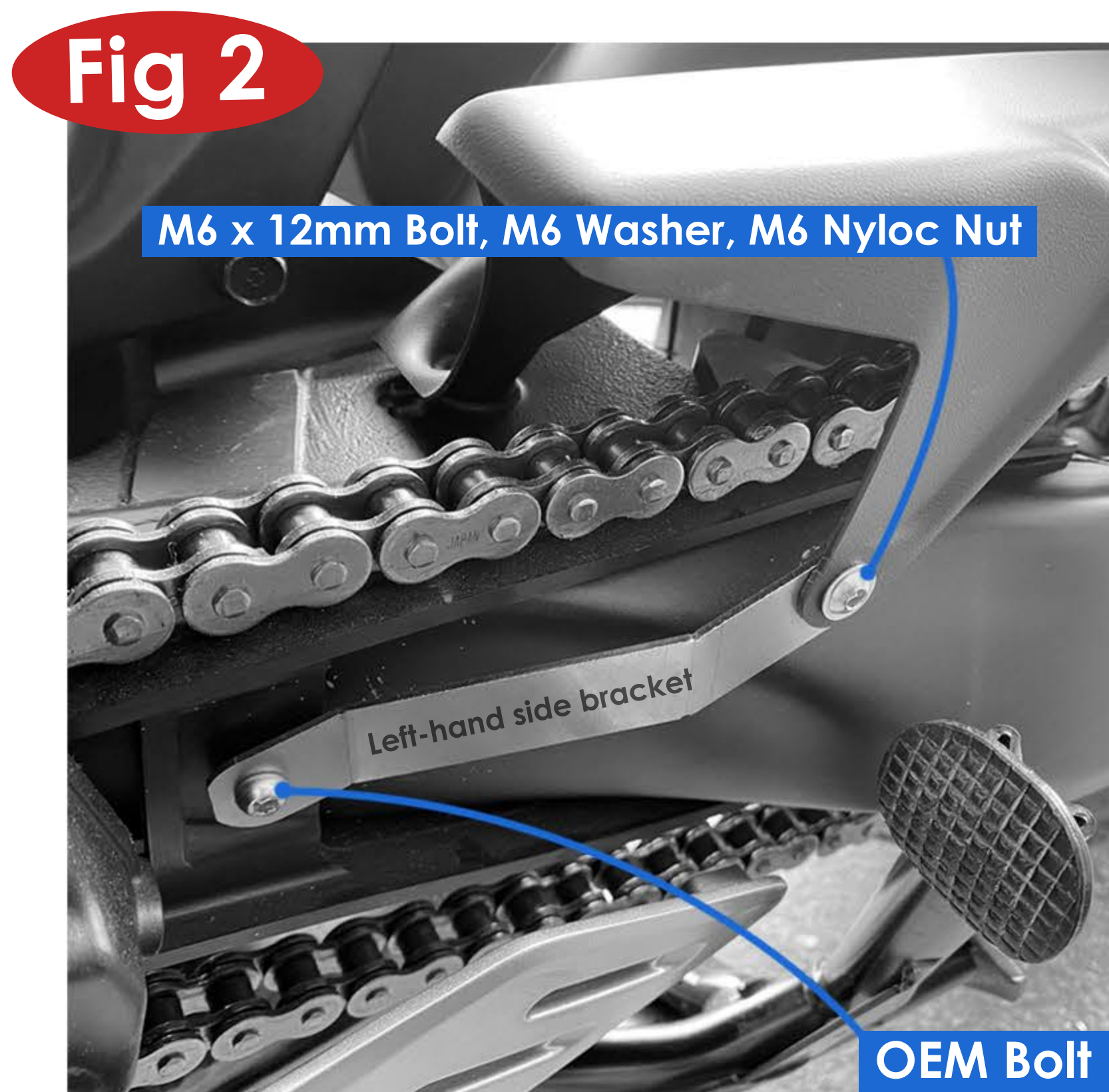
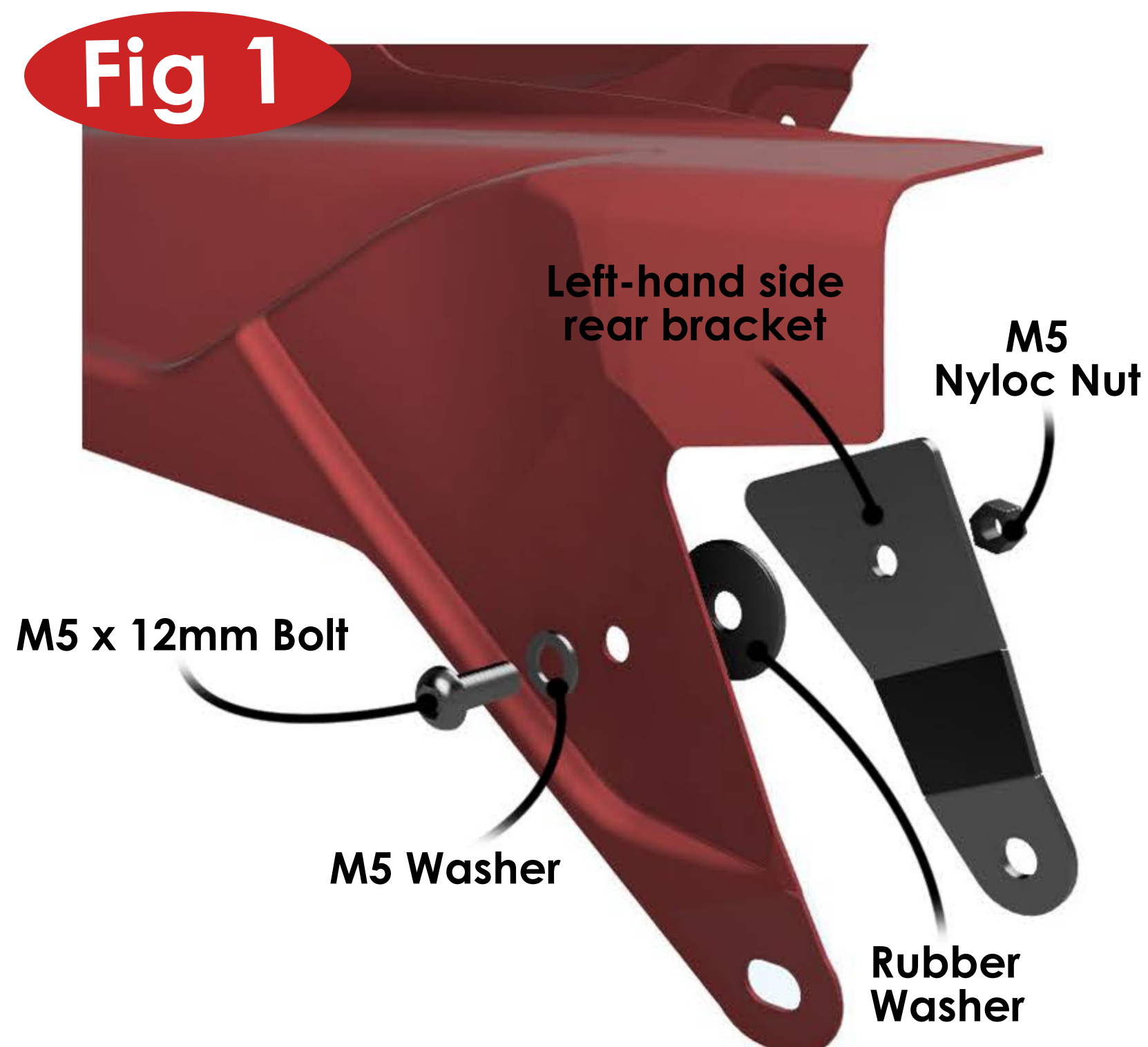

Any questions?
sales@pyramid-plastics.co.uk
 +44 (0)1427 677990
www.pyramid-plastics.co.uk

