



# INSTALLATION GUIDE

## TRANSIT VAN REAR TIRE CARRIER AND LADDER TR1106B



### TOOLS REQUIRED (NOT INCLUDED)

- |                      |                           |
|----------------------|---------------------------|
| + 6MM ALLEN WRENCH   | + 5/32" ALLEN WRENCH      |
| + 13MM SOCKET        | + POWER DRILL             |
| + 13/16" SOCKET      | + 3/16" DRILL BIT         |
| + 9/16" WRENCH       | + 27/64" DRILL BIT        |
| + 7/16" WRENCH       | + 3/4" WRENCH             |
| + 7/32" ALLEN WRENCH | + AUTO PANEL REMOVAL TOOL |

### INSTALL INFO

TIME TO INSTALL THIS PRODUCT: 1-2 HOURS

Additional help is suggested for a few of the install steps.

### BEFORE YOU START

Please inspect the product and packaging upon delivery to ensure there are no issues and that all parts and hardware are accounted for.

Contact us ASAP if anything is missing at:  
[support@flatlinevanco.com](mailto:support@flatlinevanco.com)

# BEFORE YOU START

All Flatline Van Co products must be properly assembled and secured before attaching to your vehicle. Improper attachment could result in an automobile accident, and could cause serious bodily injury or death to you or to others involved. You are responsible for assembling and securing Flatline Van Co products to your vehicle, checking the mounting points and attachments prior to use, and regularly inspecting the products for wear and or damage. We always recommend you use a professional to install any aftermarket accessories to your vehicle. If you have no mechanical experience and are not thoroughly familiar with the installation procedures, you must have the product installed by a professional installer or other qualified persons. The responsibility is yours and must be taken seriously for everyone's safety.



# PACKAGE CONTENTS

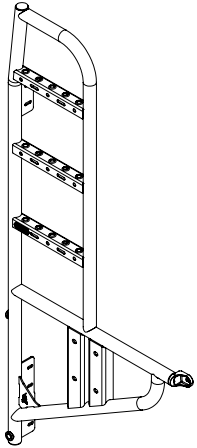

**TIRE CARRIER**  
QTY: 1

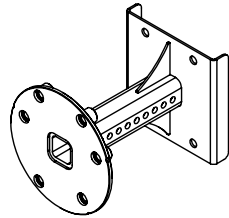

**WHEEL BRACKET**  
QTY: 1



**BACKER PLATES**  
QTY: 2



**FRONT DRILL TEMPLATE**  
QTY: 1

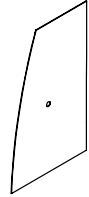

**SIDE DRILL TEMPLATE**  
QTY: 1

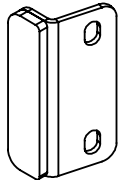

**FRAME BRACE**  
QTY: 1

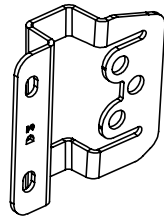

**LOWER HINGE BRACKET**  
QTY: 1

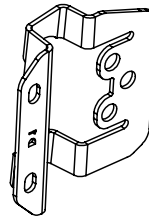

**UPPER HINGE BRACKET**  
QTY: 1

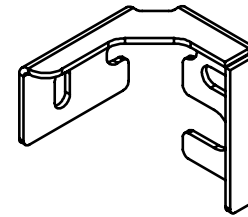

**INTERNAL BRACE**  
QTY: 1

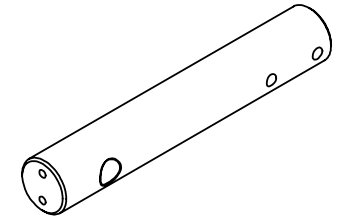

**LOCK ROD**  
QTY: 1

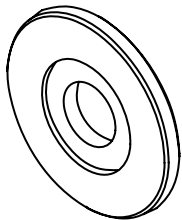

**BUSHING CAP**  
QTY: 1

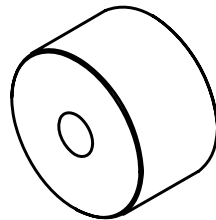

**TALL BUSHING**  
QTY: 1

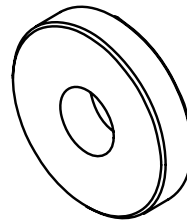

**SHORT BUSHING**  
QTY: 1

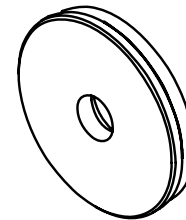

**SEALING WASHER**  
QTY: 1

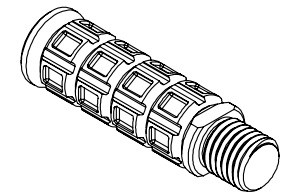

**FOOT PEGS**  
QTY: 2

# HARDWARE

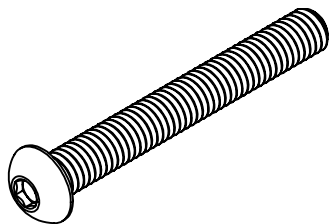

3/8-16 X 3 BUTTON HEAD  
HEX DRIVE SCREW

QTY: 1

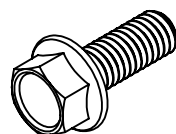

3/8-16 X 1 FLANGED HEX  
HEAD SCREW

QTY: 8

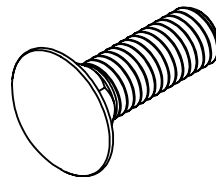

1/2-13 X 1.5 SQUARE NECK  
CARRIAGE BOLT

QTY: 4



1/4-20 X 1.0 FLANGED  
BUTTON HEAD HEX DRIVE

QTY: 1

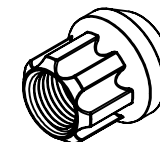

M14-1.5 LUG NUT

QTY: 3



3/8 FLAT WASHER

QTY: 9

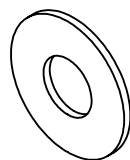

1/2 FLAT WASHER

QTY: 4



1/4 FLAT WASHER

QTY: 1

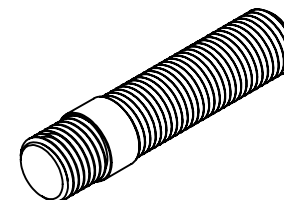

M14-1.5 X 65 WHEEL STUD

QTY: 3

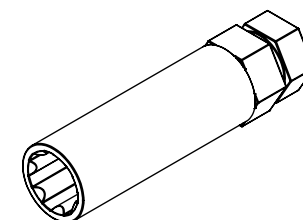

LUG NUT KEY

QTY: 1



3/8-16 NYLON LOCKNUT

QTY: 7

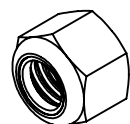

1/2-13 NYLON LOCKNUT

QTY: 4



1/4-20 NYLON LOCKNUT

QTY: 1

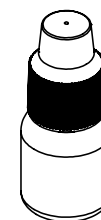

THREAD LOCKER

QTY: 1

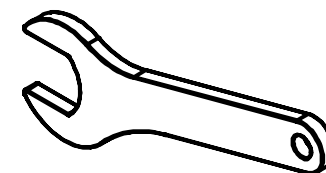

FOOT PEG WRENCH

QTY: 1

# INSTALL

TOOLS REQUIRED FOR THIS STEP: + AUTO PANEL REMOVAL TOOL

## STEP | 01 LAYOUT AND INSTALL PREP

**1.1 Door Panel Removal:** Remove the Lower Panel Trim (FIG 1) using plastic panel removal tools. Be gentle to avoid breaking the factory panel clips. If clips get stuck in the door, pop them out and slide them back into place on the trim panel.

**1.2 Vapor Barrier:** Peel back the top left corner of the factory vapor barrier (FIG 2), keeping the adhesive intact for easier reinstallation.

**NOTE-** You may have any number of different door configurations- stock full trim, stock half trim, stock panel (Pictured FIG 1), upholstered wood, etc. Each require their own removal method.

**NOTE-** Sometimes the clips will get stuck in the door. All you need to do is pop them out and slide them back in to their location on the trim panel.

**\*\*DISCLAIMER\*\***

Installing the tire carrier limits your ability to open the driver side rear door past 90° without the tire carrier making contact with your van. Please be advised to use care opening the door past 90°



FIG 1



FIG 2

- TOOLS REQUIRED FOR THIS STEP:**
- + MARKER
  - + MEASURING TAPE
  - + POWER DRILL
  - + 3/16" DRILL BIT
  - + 27/64" DRILL BIT

## STEP | 02 DRILL FOR THIRD MOUNT

**2.1 Marking Front Drill Location:** Use the **Front Drill Template** to mark the outside of the rear driver door. The arrows should align with the edge of the sheet metal under the window and the right side of the door as shown in **FIG 3**.

**2.2 Drill Front-Facing Third Mount:** Drill out your mark with a **Pilot Bit** (3/16" sized or similar) as shown in **FIG 4**, then enlarge it with a **27/64" Drill Bit**. Deburr and paint the exposed edges for rust prevention.

**2.3 Side Drill Template:** Use the **Side Drill Template** to mark the side of the rear driver door (**FIG 5**). The center of the drill hole should be about 15.25" from the door latch (**FIG 6**).

**NOTE -** Some vans may have the side door hole already. If yours does not, drill out with a 9/32" or similar-sized drill bit.

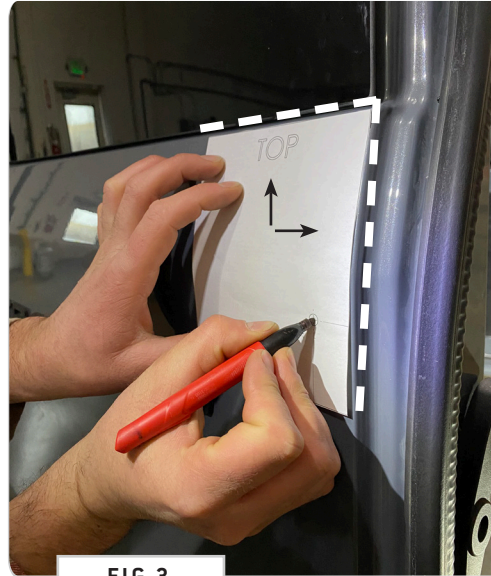

FIG 3



FIG 4

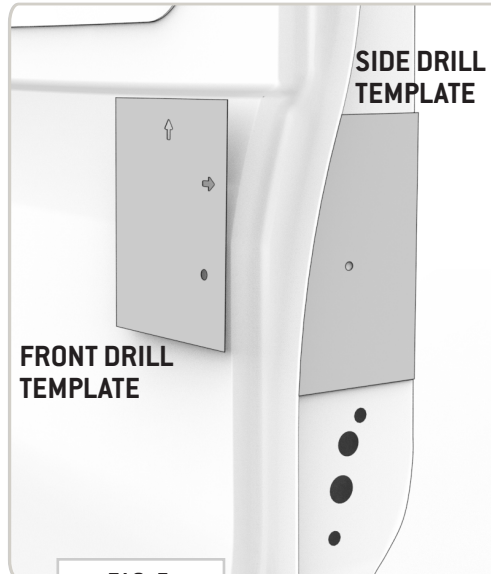

FIG 5

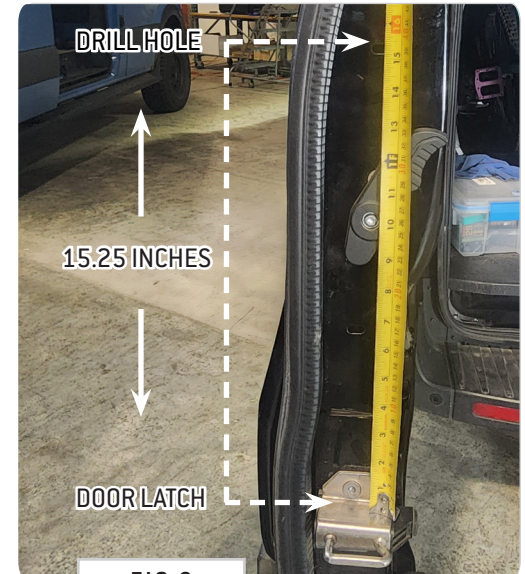

FIG 6

**TOOLS REQUIRED FOR THIS STEP:** + 3/4" WRENCH OR SOCKET  
+ 9/16" WRENCH OR SOCKET

## STEP | 03 BRACKET ASSEMBLY

**3.1 Assemble the Tire Carrier:** Attach the **Wheel Bracket** to the **Tire Carrier Frame** using: **(2) Backer Plates**, **(4) 1/2-13 X 1.5 Square Neck Carriage Bolts**, **(4) 1/2 Screw Flat Washers**, And **(4) 1/2-13 Nylon Insert Locknuts** and a **3/4" Wrench or Socket**.

**3.2 Lock Rod (Optional):** If you would like to run a lock to your wheel fasten the **Lock Rod** to the **Wheel Bracket** using **(2) 3/8-16 X 1 Hex Head Screws with Flat Washers**, **Loctite** and a **9/16" Wrench or Socket**. The depth is adjustable to suit your specific wheel setup.

**Optional:** If you have locking lug nuts, skip the lock rod installation for a clean look.

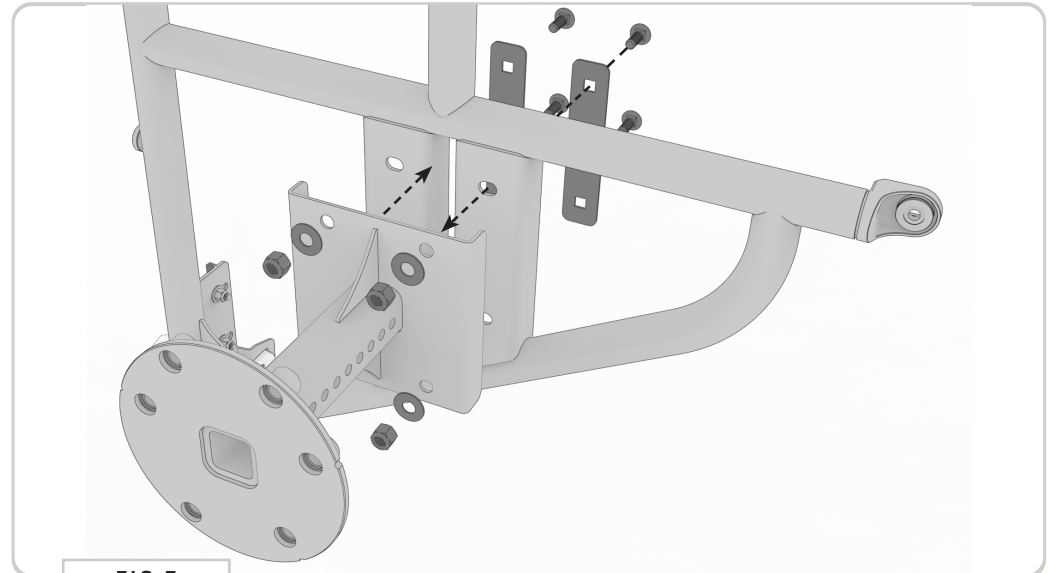

FIG 7

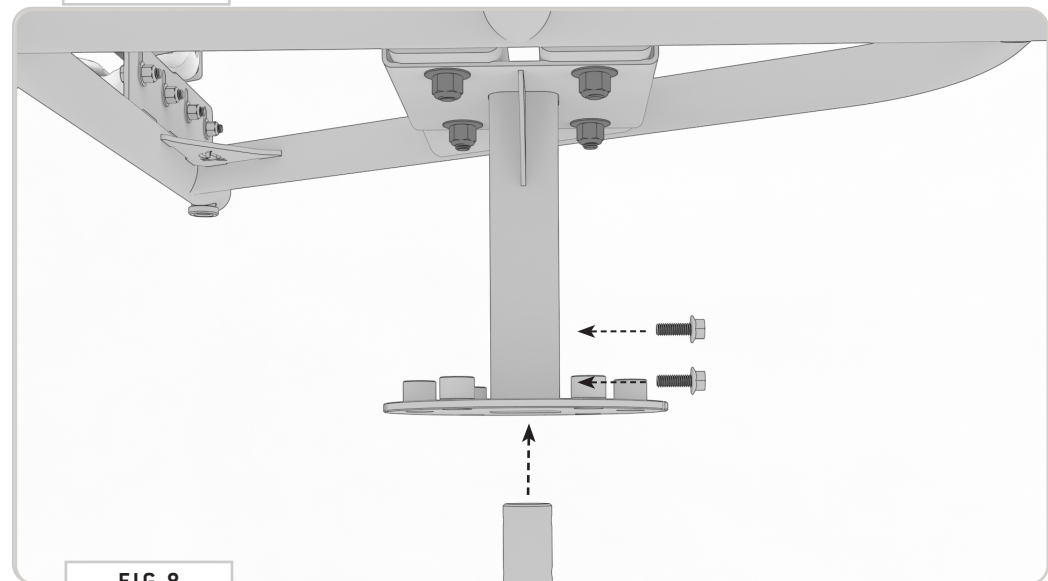

FIG 8

**TOOLS REQUIRED FOR THIS STEP:** + MARKER  
+ RATCHET  
+ 13MM SOCKET

## STEP | 04 HINGE BRACKET INSTALL

**4.1 Bottom Hinge Alignment Marks:** Begin by marking alignment points at the bottom hinge of the driver-side door (**FIG 9**).

**4.2 Release Bottom Hinge:** Remove the three factory bolts of the lower hinge using a **13MM Socket** (**FIG 10**).

**4.3** Support the door while swinging the hinge back to slide the **D2 Hinge Bracket** over it (**FIG 11**).

**4.4** Reinstall the factory bolts snugly, then check clearances by slowly closing the door before tightening the bolts (**FIG 12**).

**NOTE** - *Some adjustment may be needed to properly seat the bracket on top of the hinge.*

**4.5** Repeat the process for the upper hinge with the **D1 Hinge Bracket**. Ensure the door is supported to prevent twisting during hinge removal. After installing the **D1 Hinge Bracket**, test door function to ensure there is no contact with the van's body during operation.



FIG 9



FIG 10



FIG 11



FIG 12



TOOLS REQUIRED FOR THIS STEP:

## STEP | 05 SECURE CARRIER

**5.1 Hinge Mounts:** With assistance, raise the carrier up to the door and insert (2ea) 3/8" Flanged Hex Head Screws through the Upper (FIG 13) and Lower (FIG 14) Hinge Brackets. Loosely thread on (2ea) 3/8" Flat Washers and Nylon Locknuts.

**NOTE -** Ensure that the "fins" of the Tire Carrier are on the inside of the Hinge Brackets as shown in FIG 13 and 14.

**5.2 Third Mount:** Insert the Bushing Assembly through the third mount hole to center the carrier. (FIG 15).

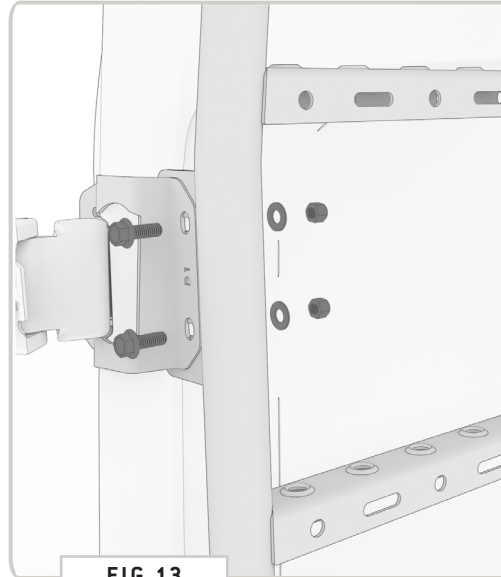

FIG 13



FIG 14

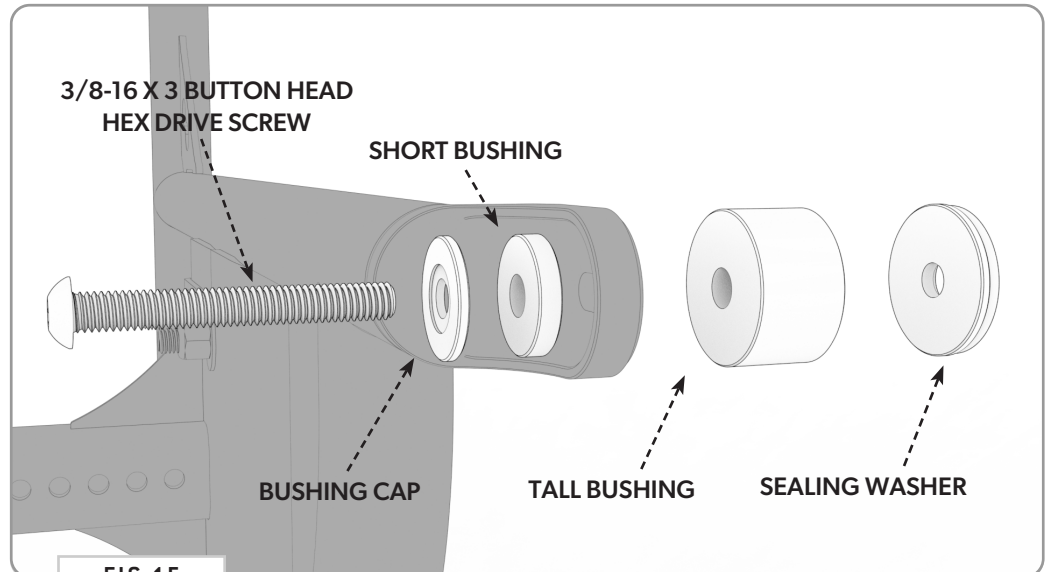

FIG 15

## STEP | 05 SECURE CARRIER

**5.3 Internal Brace:** Install the **Internal Door Brace** over the inserted **3/8" Bushing Assembly Bolt**, keeping it in place by loosely threading on a **3/8" Flat Washer and Nylon Locknut** (**FIG 16**). Align the brace with the hole on the inside of the door frame and insert a **1/4-20" Screw**, loosely threading on a **1/4" Flat Washer and Nylon Locknut** as well (**FIG 17**). Tighten down these fasteners while maintaining alignment using the tools listed above.

**5.4 Checking Clearance:** Ensure the third mount is secure, then operate the door to check for interference with mount brackets. If everything is lining up, tighten down all fasteners on the hinge mounts.

**5.5 Lower Frame Brace:** Use a **9/16" Wrench and Socket** to attach the lower frame brace tightly to the door using **(2ea) 3/8" Flanged Hex Head Screws** and **(2ea) 3/8" Flat Washers and Nylon Locknuts**.

**TOOLS REQUIRED FOR THIS STEP:**

- + RATCHET
- + 9/16" WRENCH
- + 7/16" WRENCH
- + 5/32" ALLEN WRENCH
- + 7/32" ALLEN WRENCH



FIG 16

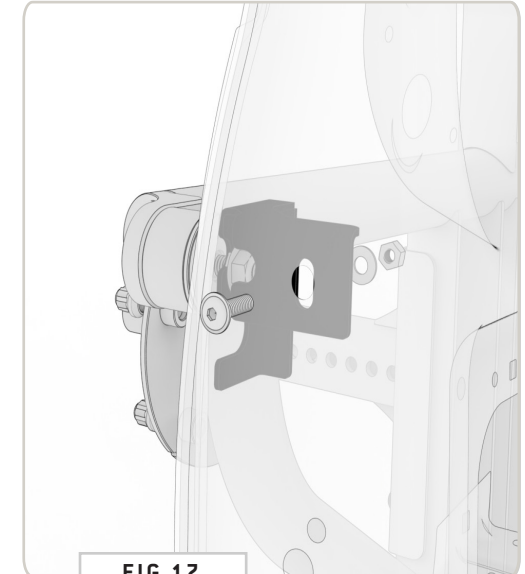

FIG 17



FIG 18



FIG 19

## STEP | 06 ATTACH WHEEL

**6.1 Wheel Studs and Lug Nuts:** Apply Loctite to the **Wheel Studs** on the short end and screw them into the notched locations on the **Wheel Bracket**. Tighten with a **6MM Allen Wrench** (**FIG 20**).

**NOTE** - The notched stud locations of the wheel bracket are for the 5x160 bolt pattern and the non-notched holes are for the 6x180 bolt pattern.

**6.2 Attach the Wheel:** Lift your wheel onto the carrier and fasten the **Lug Nuts** using the supplied **Lug Nut Key**. Tighten well with a **13/16" Socket** (**FIG 21**).

**TOOLS REQUIRED FOR THIS STEP:** + 6MM ALLEN WRENCH  
+ 13/16" SOCKET

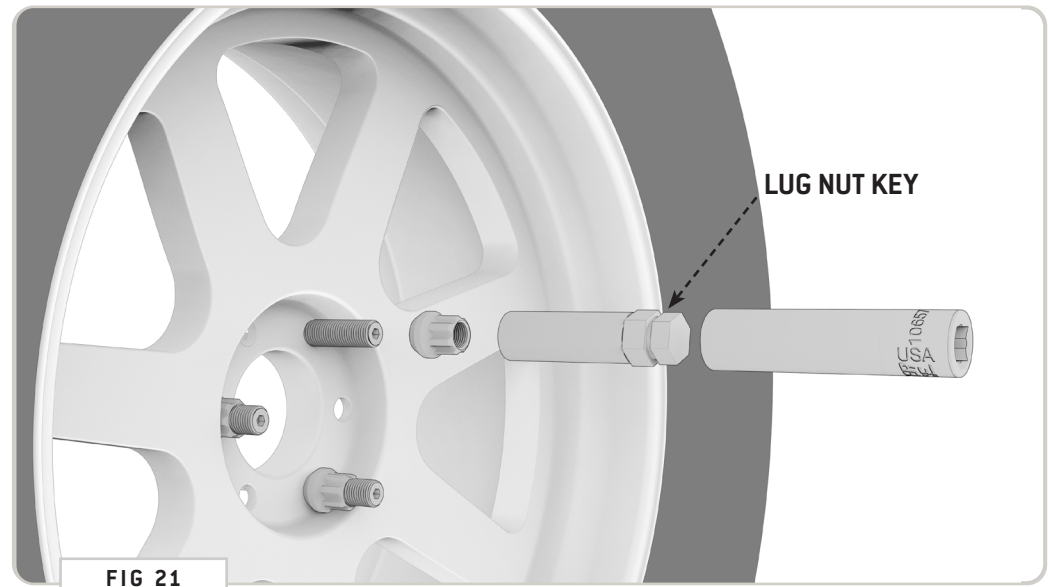
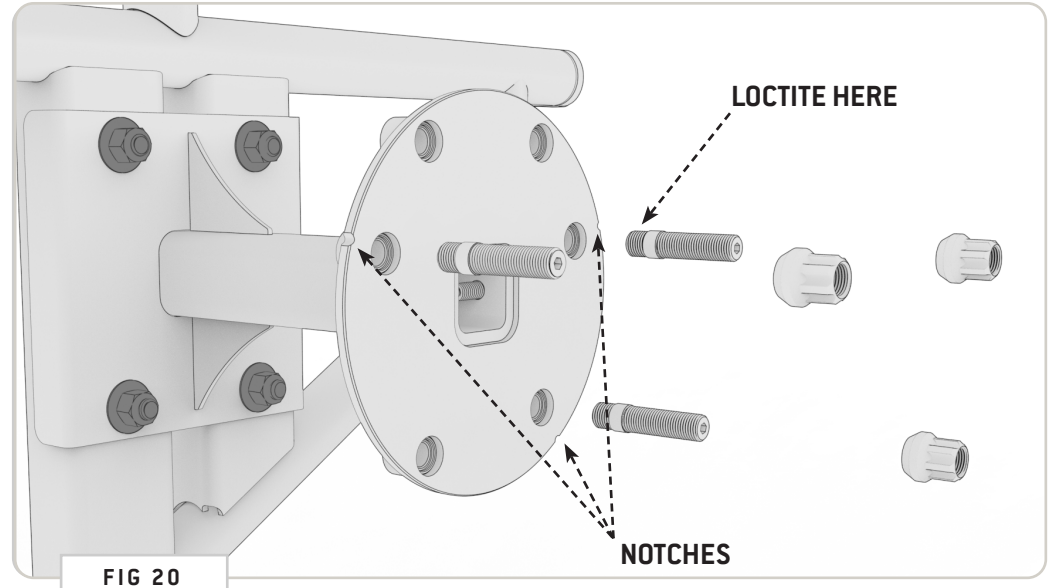

## STEP | 07 FOOT PEGS

**7.1 Foot Pegs:** Add Loctite to Foot Peg threads and install to locations shown in FIG 22 using the provided **Foot Peg Wrench**. (FIG 23).

**TOOLS REQUIRED FOR THIS STEP:** + FOOT PEG WRENCH  
+ LOCTITE

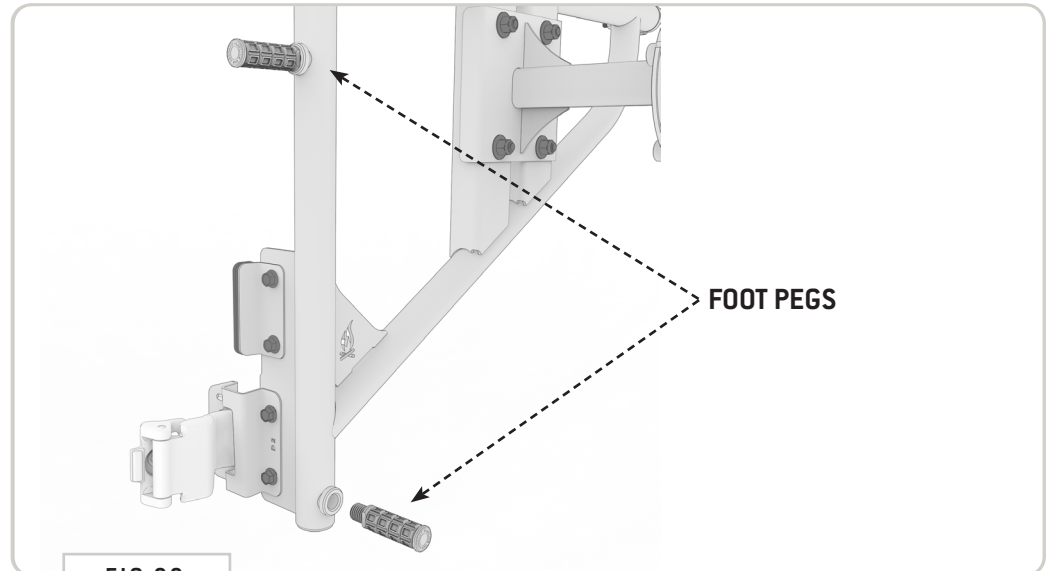

FIG 22

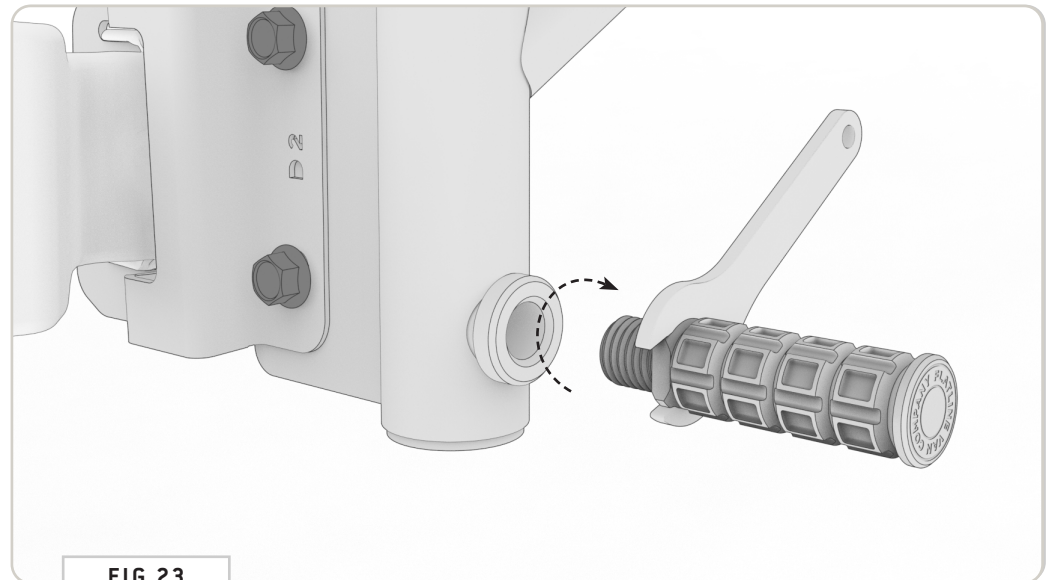

FIG 23

# GET OUT AND EXPLORE!

## + LEAVE US A REVIEW

---

Happy with your new FVC product? We would love to hear (and see) from you! Head to the product page and click "Leave Review." Add a short review and upload a few photos to be showcased on the product page.

## + SHARE YOUR PICS

---

We love seeing how our customers use their FVC products and following along with your adventures. Tag us in your photos with: @flatlinevanco or send them to us via email. We love posting customer pictures in our feed!

## + NEED ANY HELP?

---

If you are having any issues with your product, please reach out, and we will make it right. FVC is a company of van and outdoor enthusiasts that design and use our own products, so we want you to be as stoked on your new parts as we are!



@FLATLINEVANCO