



# INSTALLATION GUIDE

## SPRINTER VAN SIDE LADDER

SP0201B



### TOOLS REQUIRED (NOT INCLUDED)

- + 9/16" WRENCH OR SOCKET
- + 7/16" WRENCH OR SOCKET
- + 7/32" ALLEN WRENCH
- + 5/32" ALLEN WRENCH
- + POWER DRILL
- + 1/2" DRILL BIT
- + 1/8" DRILL BIT

### INSTALL INFO

TIME TO INSTALL THIS PRODUCT: 1 HOUR

Additional help is suggested for a few of the install steps.

### BEFORE YOU START

Please inspect the product and packaging upon delivery to ensure there are no issues and that all parts and hardware are accounted for.

Contact us ASAP if anything is missing at:  
[support@flatlinevanco.com](mailto:support@flatlinevanco.com)

# BEFORE YOU START

All Flatline Van Co products must be properly assembled and secured before attaching to your vehicle. Improper attachment could result in an automobile accident, and could cause serious bodily injury or death to you or to others involved. You are responsible for assembling and securing Flatline Van Co products to your vehicle, checking the mounting points and attachments prior to use, and regularly inspecting the products for wear and or damage. We always recommend you use a professional to install any aftermarket accessories to your vehicle. If you have no mechanical experience and are not thoroughly familiar with the installation procedures, you must have the product installed by a professional installer or other qualified persons. The responsibility is yours and must be taken seriously for everyone's safety.



# PACKAGE CONTENTS

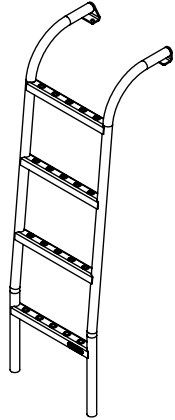

LADDER UPPER HALF

QTY: 1

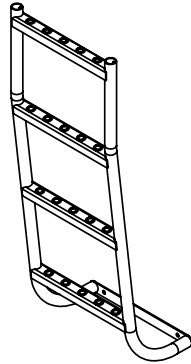

LADDER LOWER HALF

QTY: 1

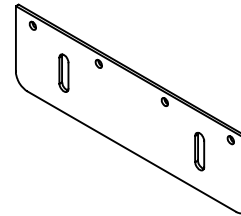

MOUNTING PLATE

QTY: 1



SUPPORT BRACKET

QTY: 1

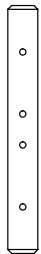

BAYONET COUPLER

QTY: 2

# HARDWARE

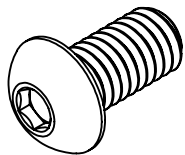

3/8-16 X 0.75 BUTTON HEAD  
HEX DRIVE SCREW

QTY: 2

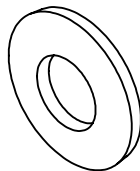

3/8 SCREW BELLEVILLE  
SPRING LOCK WASHER

QTY: 2

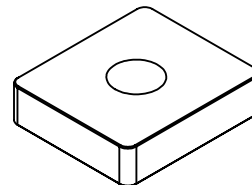

SPRINTER RAIL NUT

QTY: 2

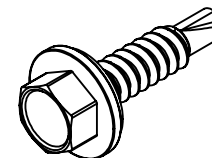

1/4 X 1 HEX HEAD WITH  
SEALING WASHER DRILLING  
SCREW

QTY: 4

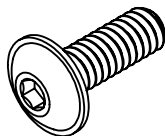

1/4-20 X 0.75 FLANGED  
BUTTON HEAD HEX DRIVE

QTY: 8

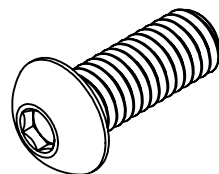

3/8-16 X 1 BUTTON HEAD HEX  
DRIVE SCREW

QTY: 3



3/8 SCREW FLAT  
WASHER

QTY: 4

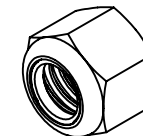

3/8-16 NYLON INSERT  
LOCKNUT

QTY: 3

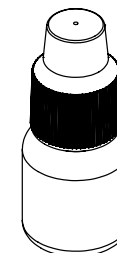

5ML THREADLOCKER  
BOTTLE

QTY: 1

# INSTALL

## STEP | 01 LAYOUT AND INSTALL PREP

**1.1 Identify Van Configuration:** There could be any number of accessories mounted to your van that may inform the way you approach the install of your **Side Ladder** (Roof Racks, Side Steps, Water Tanks, etc.) See **FIG 1** for key areas that will need accessed.

**NOTE -** The van pictured is a 144" High Roof Sprinter, but the same principles apply to the 170"

**NOTE -** You may need to loosen or temporarily remove mounted accessories to gain sufficient access to the Roof Rail and Pinch Seam of your van.

TOOLS REQUIRED FOR THIS STEP:

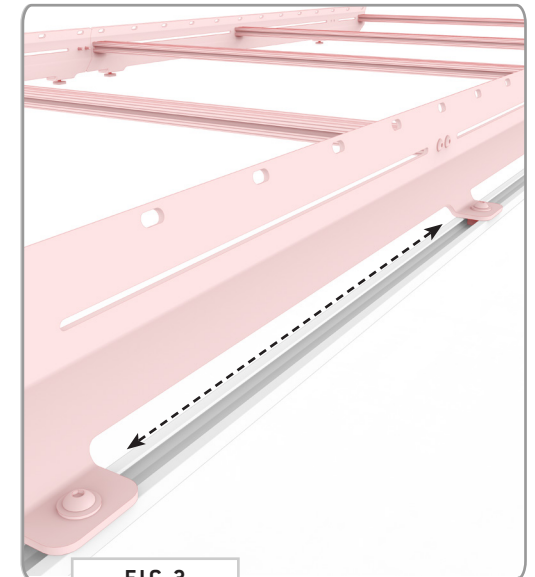
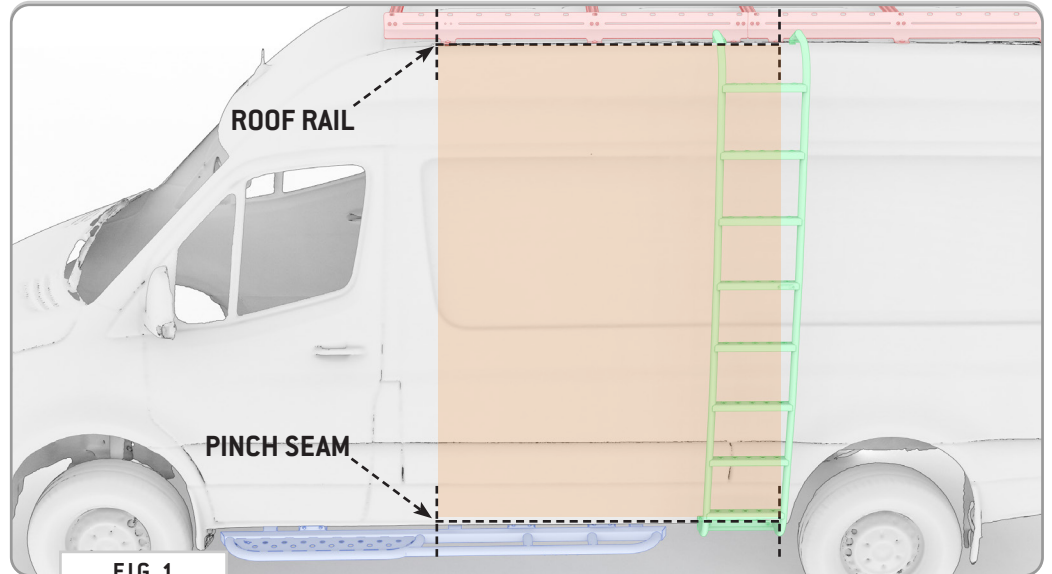

TOOLS REQUIRED FOR THIS STEP: + 5/32" ALLEN WRENCH

## STEP | 02 SIDE LADDER ASSEMBLY

**2.1 Install Bayonets to Top Ladder Half:** Find the **Top Half** of the **Side Ladder** and insert **Bayonets** as shown in **FIG 4**. Secure using **(2ea)** **1/4-20 x 0.75 Flanged Button Head Hex Drive Screws** and **Loctite**.

**2.2 Attach Bottom Ladder Half:** Find the **Bottom Half** of the **Side Ladder** and attach to protruding Bayonets using **(2ea)** **1/4-20 x 0.75 Flanged Button Head Hex Drive Screws** and **Loctite** as shown in **FIG 5-7**.



TOOLS REQUIRED FOR THIS STEP: + 7/32" ALLEN WRENCH

## STEP | 03 SIDE LADDER FITTING

**3.1 Roof Rail Nuts:** Slide in **Rail Nuts** to location of install along the Roof Rail (**FIG 8+9**). In this case, directly above the Rear Wheel Well.

*NOTE - If you already have a Roof Rack installed, this can be a somewhat lengthy process.*

**3.2 Attach Side Ladder:** Loosely secure **Side Ladder** to **Rail Nuts** using (2) 3/8-16 x 0.5" **Button Head Hex Screws** and **Lock Washers** (**FIG 10+11**).

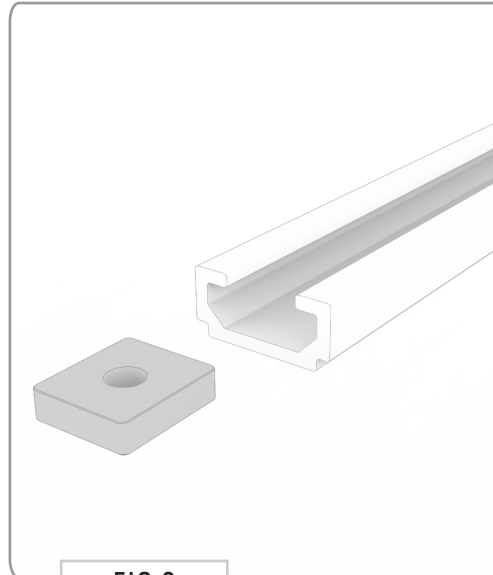

FIG 8

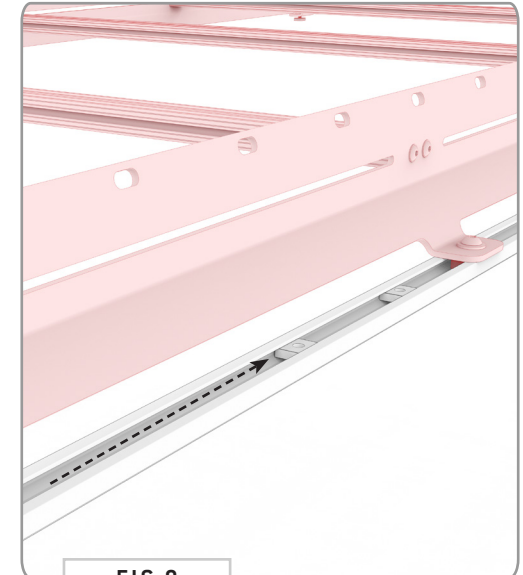

FIG 9

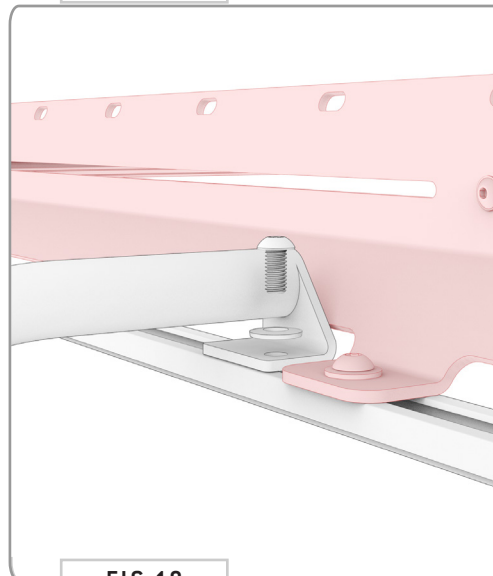

FIG 10

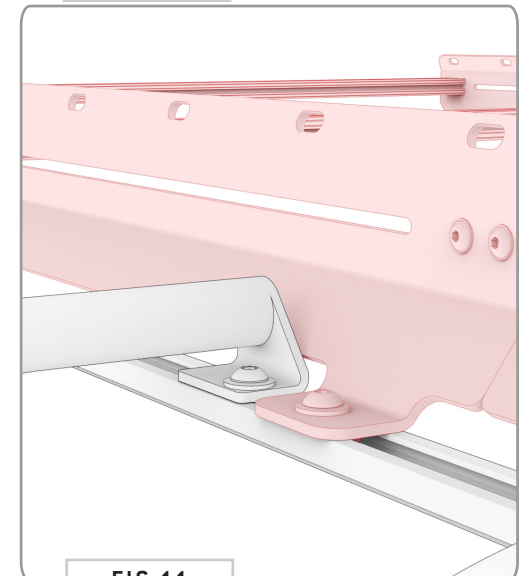

FIG 11

## STEP | 04 SIDE LADDER ALIGNMENT

**4.1 Position Side Ladder:** Position **Side Ladder** in desired location (**FIG 12**).

**NOTE-** We like the ladder as close to the rear wheel well as we can in order to utilize the **Support Bracket**.

**4.2 Attach Mounting Brackets:** Take the **Mount Plate** and the **Support Bracket** (if applicable) and loosely attach them to the bottom of the ladder using the **3/8-16 X 1" Screws**, **3/8 Flat Washers**, and **3/8-16 Nylock Nuts** (**FIG 13**).

**4.3 Drill for Support Bracket (if applicable):** Locate where the support bracket lands on the chassis beam shown in **FIG 14** and use it to mark the thru hole to be drilled. Once marked, swing the bracket out of the way so you can access with power drill. Drill through using a **1/2" Drill Bit**.

**NOTE -** Leave this support bracket loose as you fit everything in place, or you'll likely need to loosen it again.

**NOTE -** Make sure that the ladder is straight up and down.

### TOOLS REQUIRED FOR THIS STEP:

- + 7/32" ALLEN WRENCH
- + 9/16" WRENCH OR SOCKET
- + POWER DRILL
- + 1/2" DRILL BIT



FIG 12



FIG 13



FIG 14



## STEP | 05 SIDE LADDER INSTALL

**5.1 Fastening Support Bracket to Van (if applicable):** After drilling, swing the bracket back in place and loosely attach using (1) 3/8-16 x 1" Screw, 3/8 Flat Washer, and 3/8-16 Nylock Nut (FIG 15).

**5.2 Fastening Mount Plate to Van:** Slide the **Mount Plate** up as tight to the pinch seam as you can (FIG 16) and temporarily tighten the two bolts holding it to the Ladder. Using the **Mount Plate** as a guide, drill pilot holes for the two center holes along the pinch seam, then drive 1/4" **Self Drilling Screws** through them to hold it in place. You'll have to remove the ladder to get to the remaining two (2) as they sit behind the ladder uprights and are not easily accessible without a 90-degree drill head.

**5.3 Tighten Down All Fasteners:** Go back and tighten down your fasteners along the Roof Rail and Mounting Brackets.

**NOTE** - *If desired, you can replace the self drilling screw with 1/4-20 bolts & nuts.*

**TOOLS REQUIRED FOR THIS STEP:**

- + POWER DRILL
- + 1/8" DRILL BIT
- + 9/16" WRENCH OR SOCKET
- + 7/32" ALLEN WRENCH
- + 7/16" WRENCH OR SOCKET
- + 5/32" ALLEN WRENCH

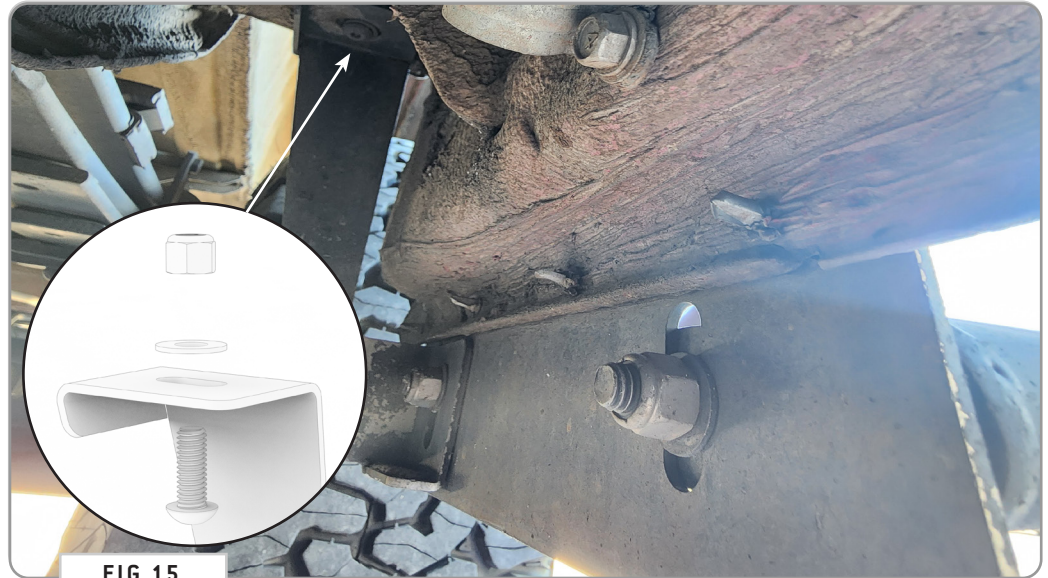

# GET OUT AND EXPLORE!

## + LEAVE US A REVIEW

---

Happy with your new FVC product? We would love to hear (and see) from you! Head to the product page and click "Leave Review." Add a short review and upload a few photos to be showcased on the product page.

## + SHARE YOUR PICS

---

We love seeing how our customers use their FVC products and following along with your adventures. Tag us in your photos with: @flatlinevanco or send them to us via email. We love posting customer pictures in our feed!

## + NEED ANY HELP?

---

If you are having any issues with your product, please reach out, and we will make it right. FVC is a company of van and outdoor enthusiasts that design and use our own products, so we want you to be as stoked on your new parts as we are!



@FLATLINEVANCO