



Installation Guide



Low Pro Roof Rack 144 LR SP0110B

All Flatline Van Co products must be properly assembled and secured before attaching to your vehicle. Improper attachment could result in an automobile accident, and could cause serious bodily injury or death to you or to others involved. You are responsible for assembling and securing flatline van co products to your vehicle, checking the mounting points and attachments prior to use, and regularly inspecting the products for wear and or damage. We always recommend you use a professional to install any aftermarket accessories to your vehicle. If you have no mechanical experience and are not thoroughly familiar with the installation procedures, you must have the product installed by a professional installer or other qualified persons. The responsibility is yours and must be taken seriously for everyone's safety.



thanks.

THANK YOU!

ARE YOU EXCITED ABOUT YOUR NEW LOW PRO ROOF RACK 144? HERE ARE A FEW THINGS TO DO BEFORE BEGINNING THE INSTALLATION PROCESS--

- PLEASE INSPECT THE PRODUCT TO ENSURE THERE WAS NO DAMAGE INCURRED DURING SHIPPING.
- IF THERE IS DAMAGE TO REPORT, PLEASE CONTACT OUR CUSTOMER SERVICE DEPARTMENT AS SOON AS POSSIBLE.
- NEXT, USING THE "PACKAGE CONTENTS" PAGE, CHECK INVENTORY AND FAMILIARIZE YOURSELF WITH THE PARTS AND HARDWARE.
- GATHER ALL TOOLS REQUIRED FOR INSTALL.
 - 5/32 HEX KEY ALLEN WRENCH
 - 7/32 HEX KEY ALLEN WRENCH

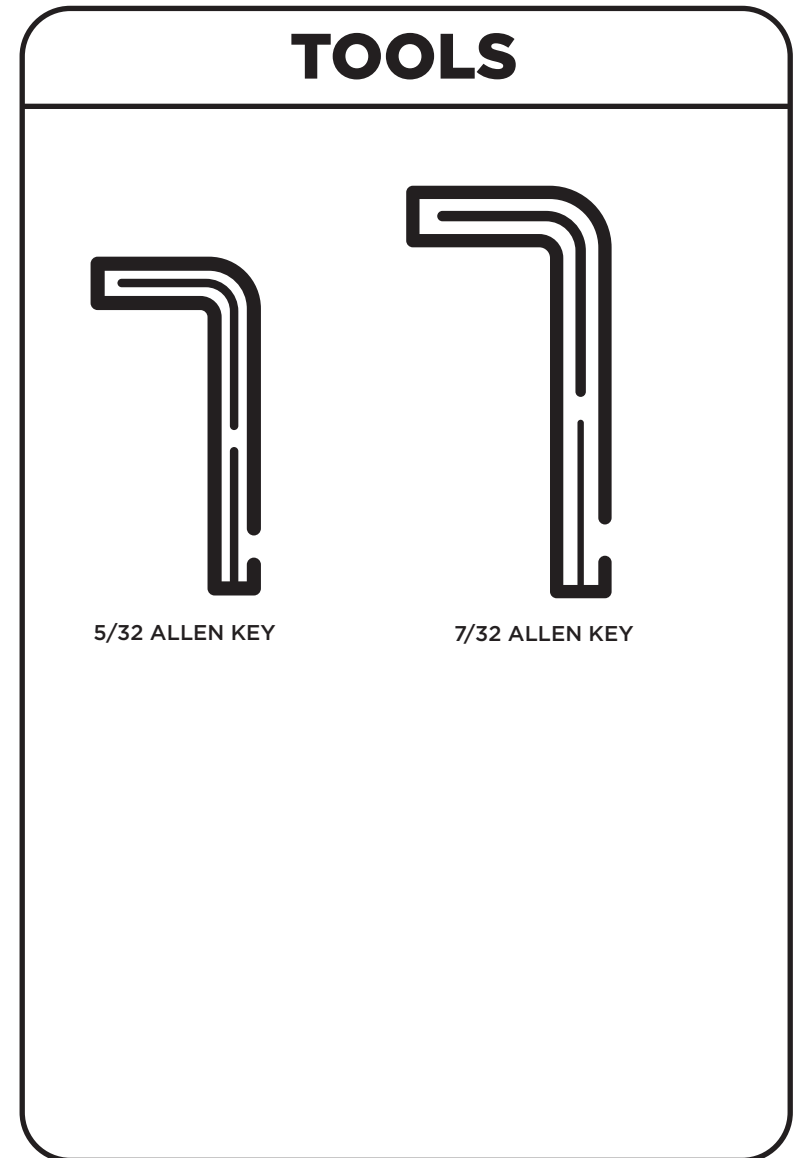

PACKAGE CONTENTS

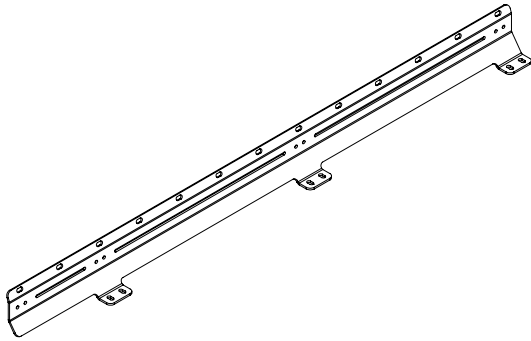

LEFT SIDE RAIL
QTY-2

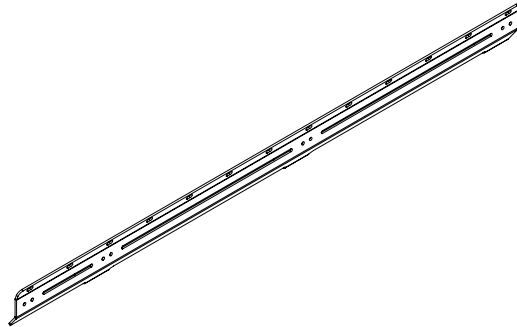

RIGHT SIDE RAIL
QTY-2

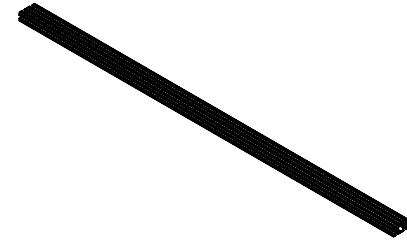

CROSSBAR
QTY-6

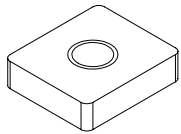

RAIL NUT
QTY-24

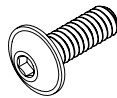

1/4-20 FLANGE HEAD SCREW
QTY-24

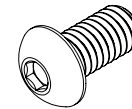

3/8-16 BUTTON HEAD SCREW
QTY-24

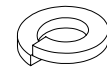

3/8 SPLIT LOCK WASHER
QTY-24



STICKER PACK
QTY-1

FVCO
Installation Guide



Low Pro Roof Rack 144
SP0101B

INSTALLATION GUIDE
QTY-1

LET'S GET STARTED!

1. SLIDE HALF OF THE RAIL NUTS INTO THE PASSENGER SIDE FACTORY ROOF RAIL, AND HALF OF THEM INTO THE DRIVER SIDE RAIL.
2. SPACE OUT THE RAIL NUTS CLOSE TO THE FINAL POSITION (GROUPS OF 2) SEE **FIGURE 1** FOR ROUGH REFERENCE DIMENSIONS.
NOTE- 2 FEET PADS MEET IN THE CENTER OF THE RACK

RAIL NUT

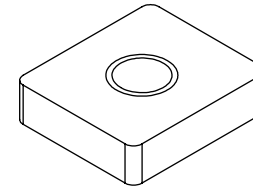
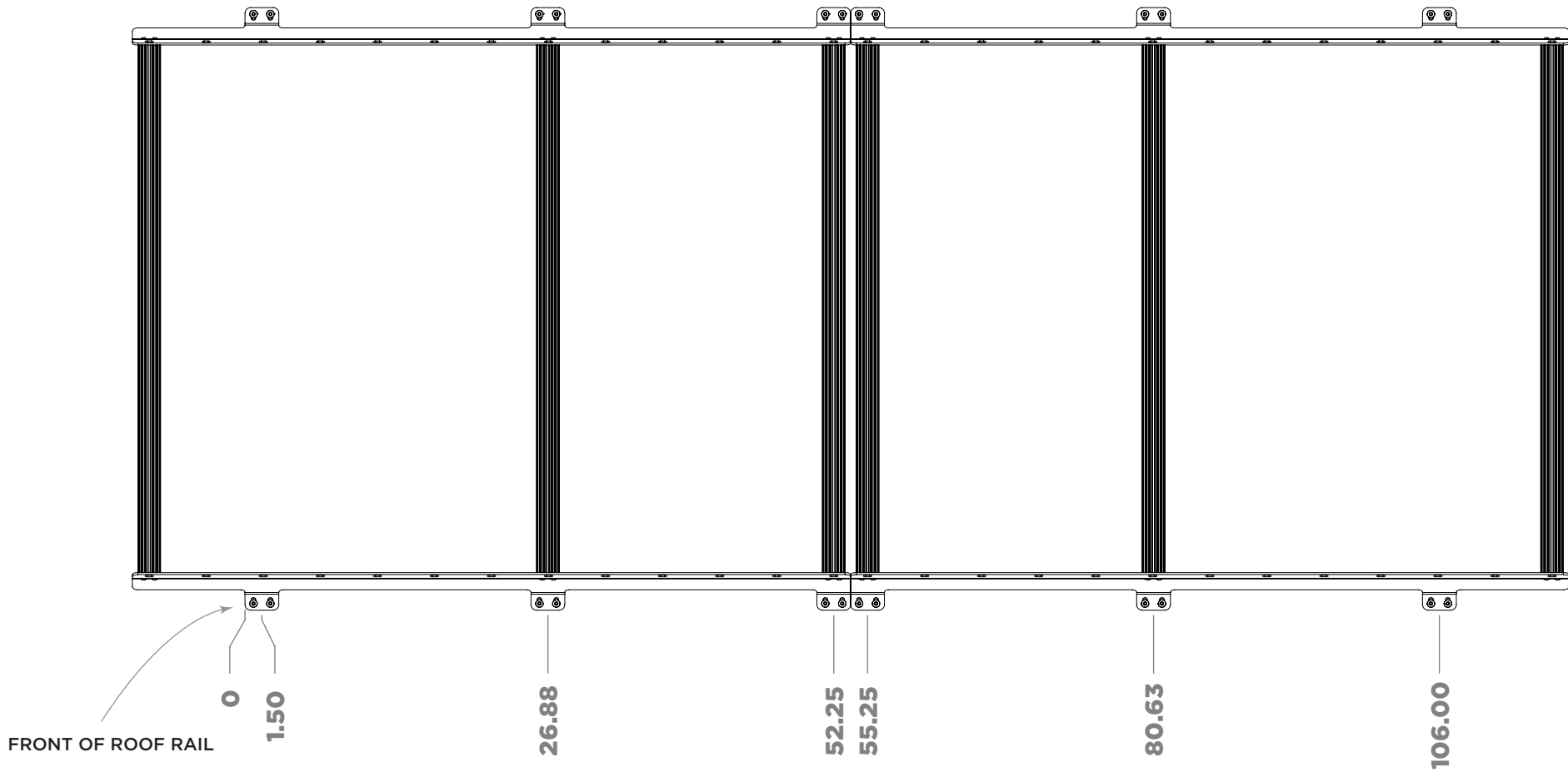

FIGURE 1



USE THESE DIMENSIONS FOR ROUGH REFERENCE ONLY

3. BEGINNING WITH THE FORWARD SECTION OF THE RACK (SEE **FIGURE 2** FOR LAYOUT), START *LOOSELY* ATTACHING THE SIDE RAILS TO THE ROOF RAILS USING THE 3/8-16 BUTTON HEAD SCREW & 3/8 SPLIT LOCK WASHER, BUT DO NOT TIGHTEN ALL THE WAY DOWN (SEE **FIGURE 3** FOR DETAIL)

FIGURE 2

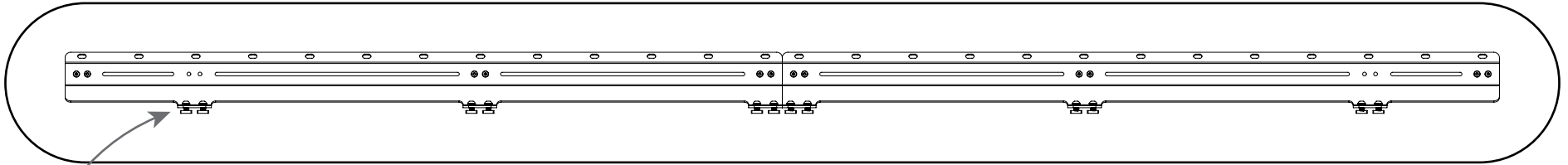

NOTE- FRONT "FOOT" OF RACK SHOULD BE AS FAR FORWARD IN ROOF RAIL AS IT CAN GO.

FIGURE 3

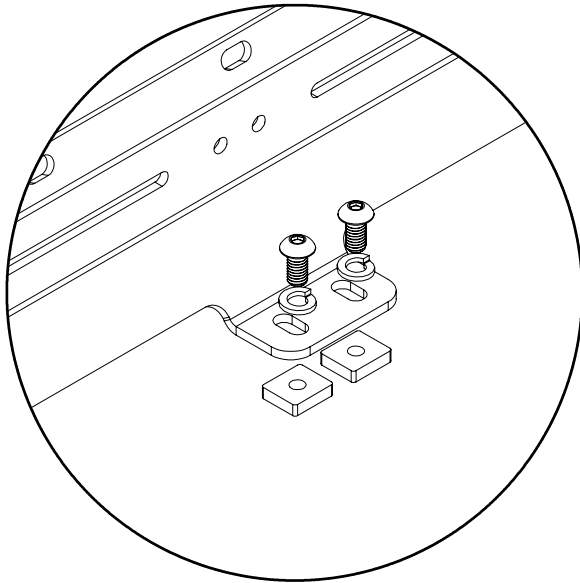

NOTE- IF YOU ARE USING OUR F80 KIT FOR A FIAMMA AWNING REFER TO THE F80 KIT INSTALL GUIDE FOR DETAILS BEFORE PROCEEDING.

4. PLACE YOUR CROSSBARS IN DESIRED LOCATION, LOOSELY BOLTING THE 1/4-20 FLANGE HEAD SCREWS IN PLACE.

NOTE- KEEP IN MIND THE LAYOUT OF YOUR ROOF TOP ARRAY (SOLAR PANELS, FANS, TENTS, ETC.) YOU CAN MOUNT CROSSBARS IN THE SET PAIR OF HOLES (SEE **FIGURE 4**), OR YOU CAN PLACE THEM IN THE SLOTS WHICH PROVIDES YOU MORE FREEDOM OF LAYOUT.

FIGURE 5

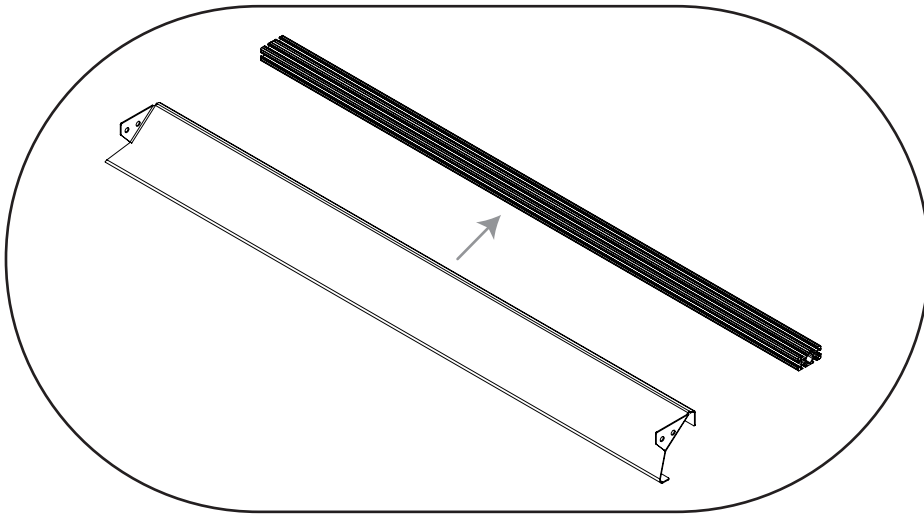
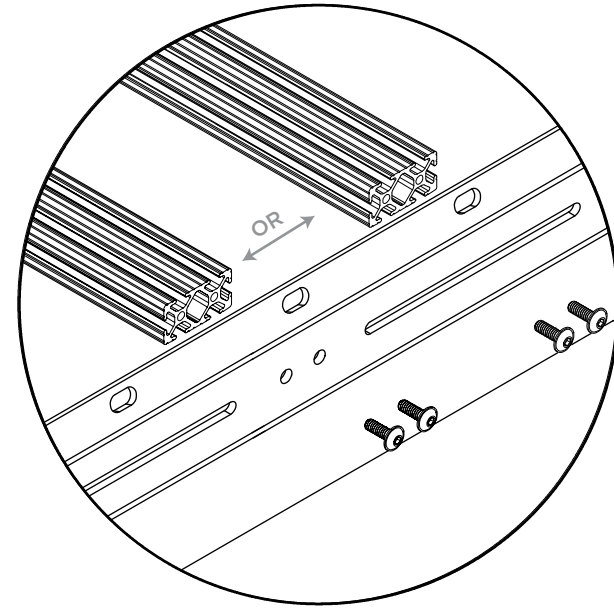

FIGURE 4



NOTE- IF INSTALLING OUR FRONT FAIRING; IT IS SUGGESTED TO BOLT THE FAIRING TO THE CROSSBAR FIRST (SEE **FIGURE 5**), THEN ATTACH THAT ASSEMBLY TO THE ROOF RACK (SEE **FIGURE 6**)

FIGURE 6

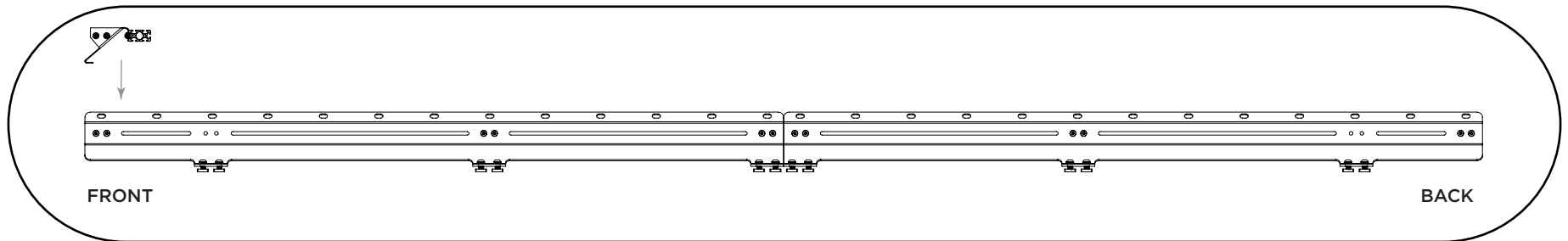
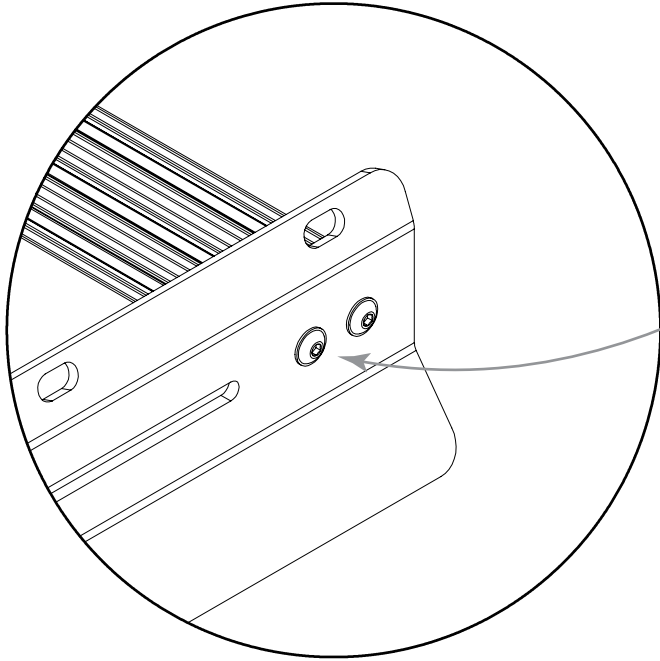

FIGURE 7



5. TIGHTEN ALL CROSSBAR BOLTS USING THE 5/32 ALLEN KEY (SEE **FIGURE 7**)
NOTE- DO NOT OVERTIGHTEN! IF YOU ARE CONCERNED ABOUT THE BOLTS BACKING OUT, YOU CAN PUT A DAB OF BLUE LOCTITE ON THE BOLTS BEFORE TIGHTENING DOWN COMPLETELY.

6. NOW TIGHTEN SIDE RAILS TO ROOF RAIL USING THE 7/32 ALLEN KEY (SEE **FIGURE 8**)

FIGURE 8

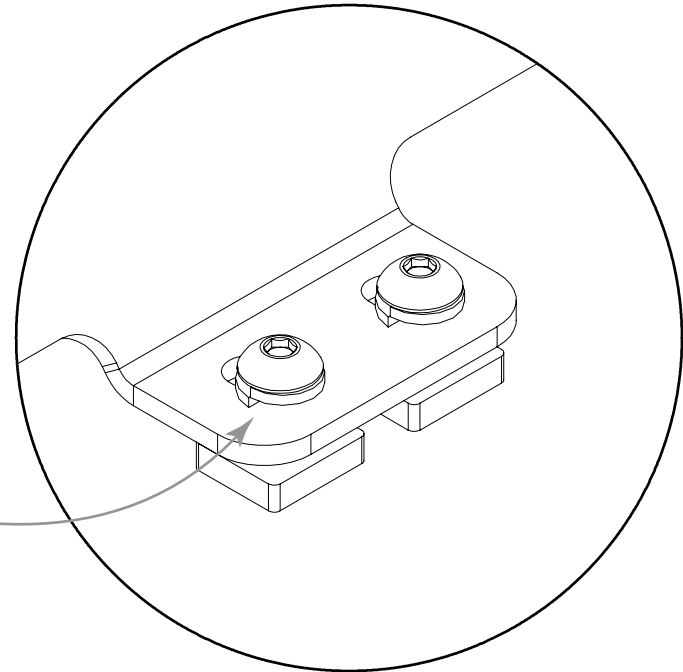

GET OUT AND EXPLORE!

LEAVE US A REVIEW

Happy with your new FVC product? We would love to hear (and see) from you! Head to the product page and click "Leave Review." Add a short review and upload a few photos to be showcased on the product page.

SHARE YOUR PHOTOS WITH US

We love seeing how our customers use their FVC products and following along with your adventures. Tag us in your photos with @flatlinevanco or send them to us via email. We love posting customer pictures in our feed!

CUSTOMER SUPPORT

If you are having any issues with your product, please reach out, and we will make it right. FVC is a company of van and outdoor enthusiasts that design and use our own products, so we want you to be as stoked on your new parts as we are!



@flatlinevanco



facebook.com/flatlinevanco



youtube.com/c/flatlinevanco



support@flatlinevanco.com



thanks!