

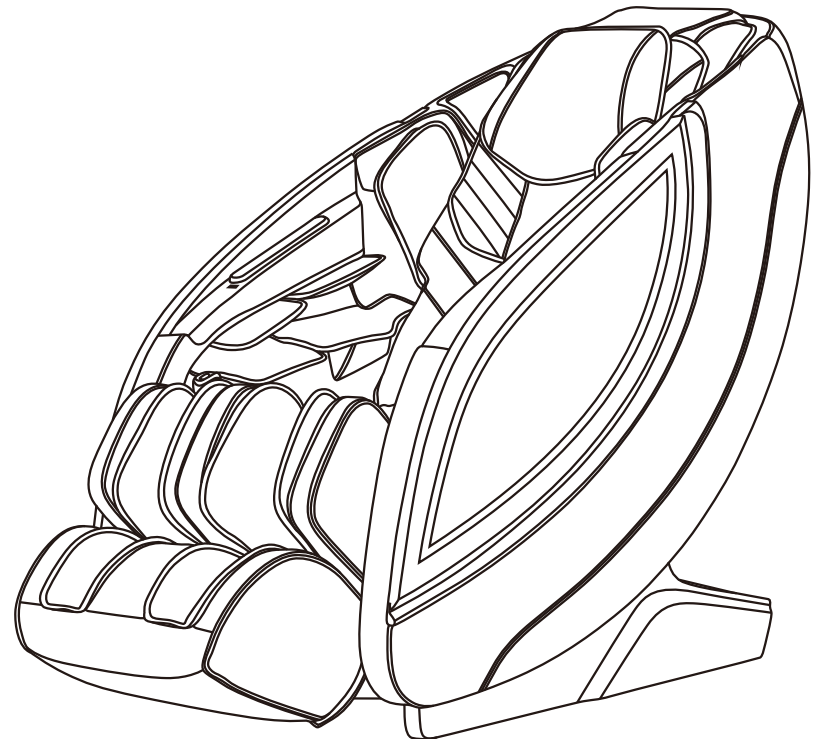

Titan Pro - 3D Cascade
MASSAGE CHAIR
OPERATION INSTRUCTIONS

SAVE THESE INSTRUCTIONS



Thank you for purchasing this product. Before you use it, please read the Operation Instructions in detail for the correct usage of this product, especially the important safety warnings. Keep the Operation Instructions properly for future reference.

Note: Our company reserves the right to change and explain any product design without prior notice. Product colors are subject to the actual products.

TABLE OF CONTENTS

Safety and Maintenance	02-03
Safety Warning	04-07
Name of Components	08
Function	09-10
Introduction to the Remote Controller	11-12
Method of Usage	13-32
I.Turn on the power supply of this product	13
II.Massage function control operation	13-31
III.Introduction to armrest shortcut keys	32
IV.Voice control mode	33
V.Turn off the power and stop massage	34
VI.Operation Instructions for Bluetooth Speaker Play	34
VII.Installation Instructions for Legrest	34
VIII.Instructions for removal and use of head cushion and backrest	35
IX.Floor Protection	36
X.Instruction for movement	36
Product Specification	37

Safety and Maintenance

1. Important Safety Warnings

- Do not allow children to touch any movable part of this product.
- Use the well-grounded power supply unit suitable for this product.
- Pull out the plug after use or before cleaning to avoid any physical injury or damage to the product.
- Operate this product as instructed in this manual.
- Do not use any parts or accessories which are not recommended.
- Do not use this product outdoors.
- Please read the Operation Instructions carefully before operation.
- Never use this product for any other purpose not listed herein.
- 20 minutes of usage each time is recommended.
- Do not use this product if the leather is broken or damaged.
- Do not use this product if the cover or leather is broken or damaged.
- Do not use this product if the radiator hole is covered or blocked.
- Do not drop anything into this product.
- Never fall asleep while using this product.
- Do not use this product if you are drunk or feel unwell.
- Do not use this product within one hour after a meal.
- Do not use this product with excessive force to avoid any injury.
- Do not carry any fragile, explosive, or combustible material in your pocket, such as a mobile phone and lighter when using the massage chair.

2. Operating Environment

- Do not use this product in a very moist environment such as the bathroom.
- Stop using this product immediately when the ambient temperature changes sharply.
- Do not use this product in any heavily-dusty or caustic environment.
- Do not use this product in a small space or a place without good ventilation.
- The normal room temperature ranges from 0 °C to 35 °C.
- Do not use this product in an excessively humid room such as a bathroom. Use it at a relative humidity between 20% and 80%.
- Do not use this product outdoors.
- Avoid direct sunlight.
- Keep this product away from any heat source such as a stove and air outlet of an air conditioner.
- Do not use this product during thunder or lightning weather.
- Do not use this product in dusty places.

3. The following populations should not use this product

- Patients with osteoporosis.
- Patients with heart disease or wearing electronic medical devices such as a pacemaker.
- People who have a fever.
- Pregnant women or women on their menstrual period.
- Patients who are injured or have a skin disease.
- When unsupervised, any children are under the age of 14 and those unconscious are not allowed to use this product.
- People who are told by their physicians to have rest or who feel unwell.
- People whose bodies are wet are forbidden to use this product.
- This product has a hot surface. Persons insensitive to heat must pay attention when using this product.

Safety and Maintenance

4. Safety Precautions

- Check whether voltage is consistent with the specification of this product.
- Never insert or pull out the plug with a wet hand.
- Do not let water flow into this product to avoid electric shock or cause damage to this product.
- Do not pull the power cord when plugging or unplugging it. Rough handling is forbidden.
- Do not damage the wire or modify the circuit of this product.
- Do not clean live parts of this product with a wet cloth such as a power switch and plug.
- Be away from this product in case of power failure to avoid any injury if power is restored suddenly.
- Stop using this product at once while it works abnormal, and consult your local supplier.
- Stop using this product if you feel unwell, and consult your health care practitioner.
- This product is not intended for use by persons (including children) with reduced physical, sensory or mental capabilities, or lack of experience and knowledge, unless they have been given supervision or instruction concerning the use of this product by the personnel responsible for their safety. Children should be supervised to ensure that they do not play with this product.
- If the power cord is damaged, it must be replaced by the manufacturer, its service agent or similarly qualified staff in order to avoid hazards.

5. Product Service and Maintenance

- This product should be maintained by the service center designated by the manufacturer only. No user should disassemble or maintain it without permission.
- Do not forget to turn off the main power switch after usage.
- Do not use this product if the power socket becomes loose.
- If this product will be left unused for a long period of time, it is necessary to roll up the power cord of this product and store this product in a dry and dust-free environment.
- Do not store this product at a high temperature or near open flame. Avoid prolonged exposure to direct sunshine.
- Please clean this product with dry cloth. Never use thinner, benzene or alcohol.
- The mechanical components of this product are specially designed and manufactured, so no special maintenance is needed.
- Do not use a sharp object to stab at this product.
- Do not roll or pull this product on any uneven ground. Instead, it should be lifted before moving.
- Please use this product intermittently. Do not keep it working continuously for a long period of time.

6. Solutions to Ordinary Malfunctions

- If the motor sounds during operation of this product, this is the normal operation sound.
- If the controller cannot work normally, check whether the plug and the power socket are connected reliably, and whether the power switch is turned on.
- If the rated working time is over, this product will automatically activate the power-off button; If this product keeps operating for a long period of time, the temperature protector will stop this product automatically. The product can be used again after half an hour.

7. Storage Conditions

- Storage room temperature: -5 °C to 35 °C.
- Relative humidity (RH) between 20% and 80%; free of corrosive gases, and a well-ventilated room.

Safety Warning

⚠ Warning

When the legrest of the massage chair is lifted, nobody should apply pressure on the legrest to prevent the massage chair from falling forward which will damage this product or result in personal injuries.

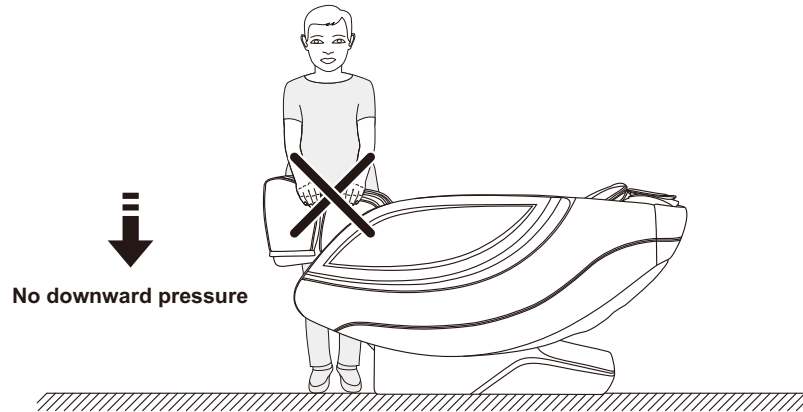

⚠ Warning

Before sitting on the massage chair, make sure that the massage chair manipulator does not stay in the seat cushion position to avoid discomfort to the buttocks during the body pressing down and any damage to the massage chair manipulator.

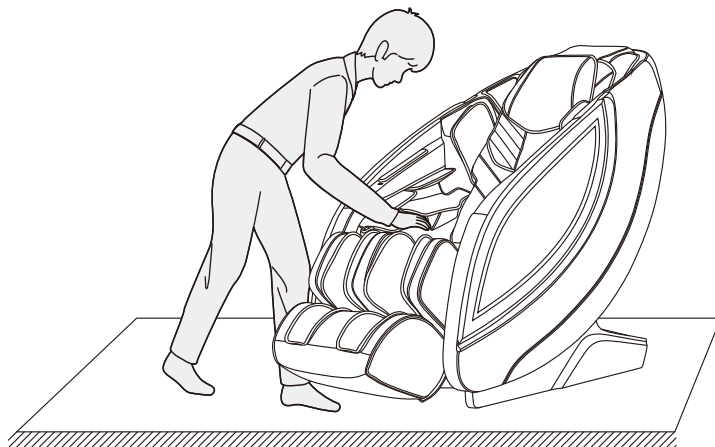

04

Safety Warning

⚠ Warning

Do not remove or pull out the remote controller cable or the power cord in the standby or power-on state to avoid any damage to this product or accidental electric shock of a body part. You are advised to unplug the remote controller cable and the power cord and put them away after you use the massage chair.

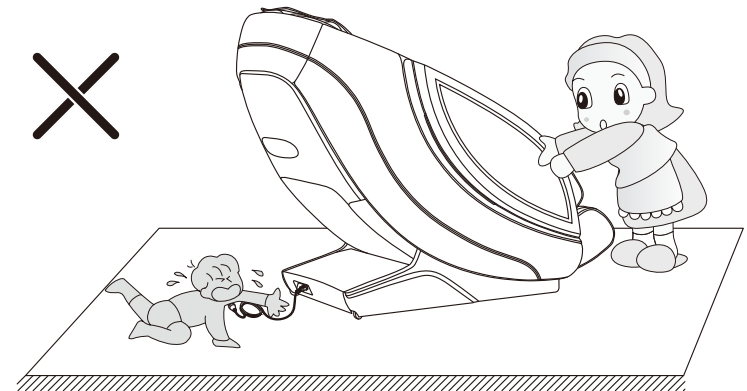

⚠ Warning

When the zero-gravity lying function is enabled, be sure to check whether there is any child or pet staying or playing under the bottom of the legrest and backrest, in order to avoid any damage to this product or physical injury.

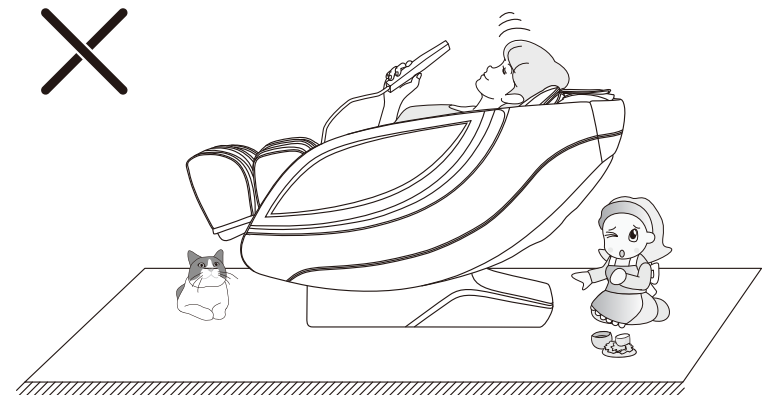

05

Safety Warning

⚠ Warning

Before using the massage chair, remove any hard objects in your pocket(s) or any jewelry carried with you (e.g. key, watch, other similar portable hard objects) to avoid any damage to this product or physical injury during massage.

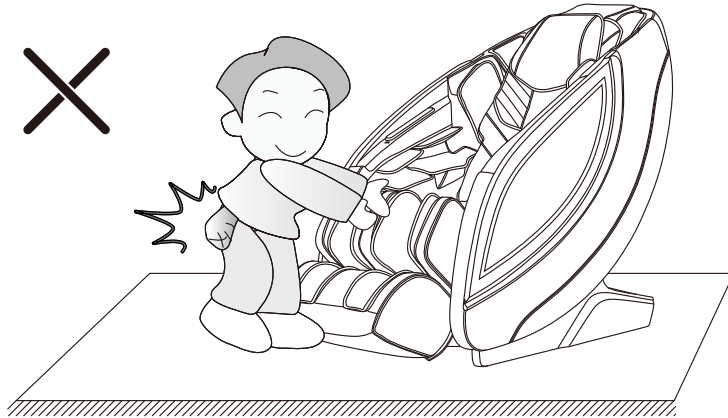

⚠ Warning

Do not unplug the power cord, or directly turn off the power switch on the back of the massage chair during massage, in order to avoid any damage to this product or physical injury.

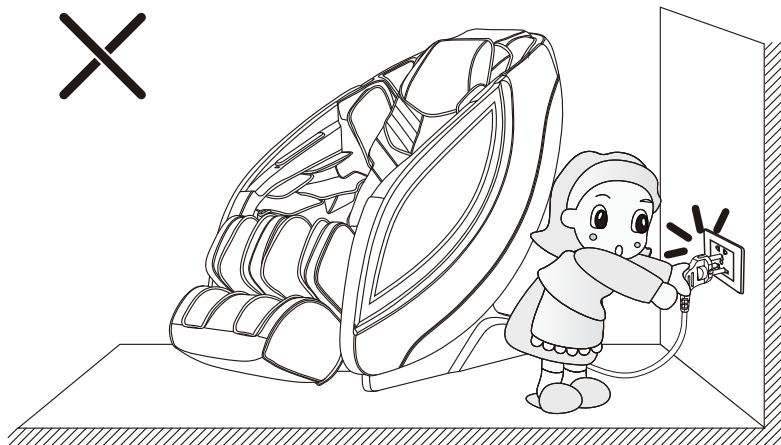

06

Safety Warning

⚠ Warning

In order to allow the calf frame and backrest frame of the massage chair to move freely, the rear of the backrest frame of the massage chair needs to keep a distance of more than 6cm from the wall, which can conveniently adjust the inclination angle of the massage chair.

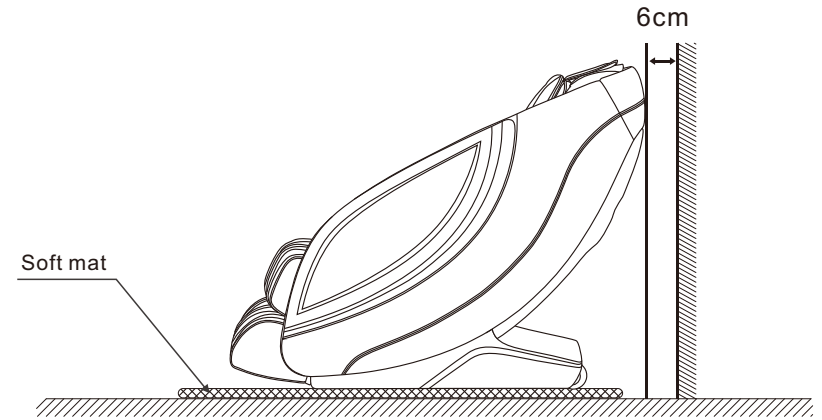

⚠ Warning

The massage chair should not be used by more than one person at the same time to avoid product failure or personal injury. In addition, do not let children play on the massage chair or climb onto the lower leg, seat cushion, foot, backrest or armrest. Otherwise, accidents or injuries may be caused.

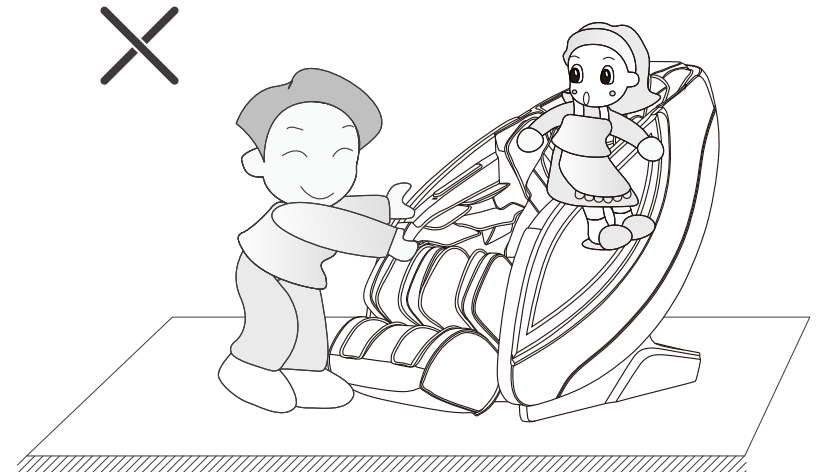

07

Name of Components

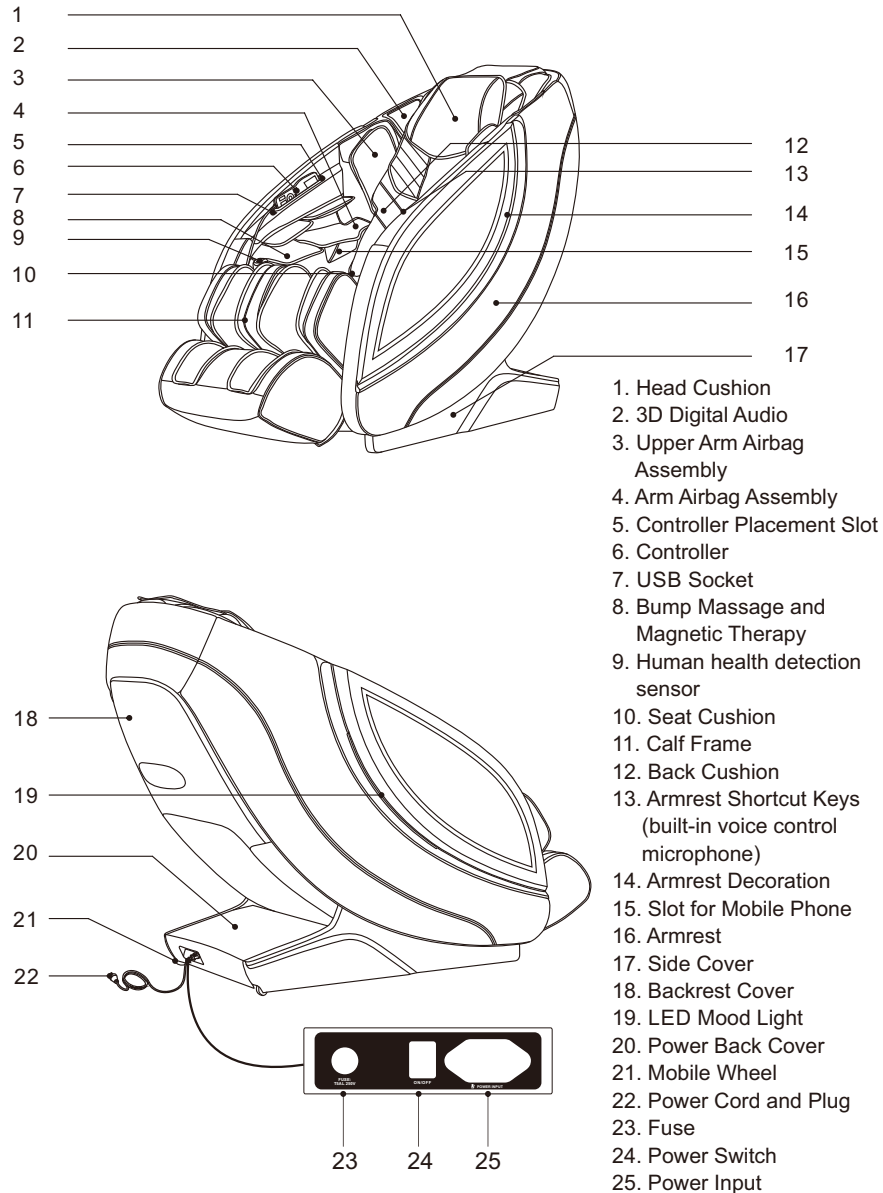

Function

- This product has been designed by a group of AI intelligent core massage manipulators that can walk up and down, stretch back and forth and silent in design.
- It is designed with the function of automatic detection and micro-adjustment of shoulder position and the automatic detection function of the human body curve and massage shiatsu point to automatically adjust the stretch back and forth of the manipulator according to the detected human body curve and massage shiatsu point, making massage more humanized and scientific.
- There are six automatic massage functions, i.e. Comfort massage, Relax massage, Neck & shoulder massage, Stretch massage, Back & waist massage and full body massage.
- There are four personalized massage functions, i.e., Massage shoulder, Massage the back, Massage waist & buttocks, Massage legs & feet.
- It is provided with five manipulator message scopes for manual selection, i.e., Spot, Partial, Full, Upper and Lower.
- It is provided with eleven manipulator massage functions for manual selection, i.e., eight massage methods such as Knead, Tap (Tap I, Tap II), Knead & Tap, Shiatsu (Shiatsu I, Shiatsu II), Grab and 3D (3D I, 3D II, 3D III, 3D IV).
- It is provided with massage adjustment functions: including five massage adjustment functions for selection, i.e., air compression force, massage intensity, massage speed, massage width and roller speed, with a total of five levels for adjustment.
- It is provided with an air compression massage function: upper arm air compression massage function (built-in 6 airbags), arm air compression massage function (built-in 8 airbags), palm air compression massage function (built-in 8 airbags), and calf air compression massage function (built-in 16 airbags), with five levels of air compression intensity for adjustment.
- It is provided with waist and calf heating functions: carbon fiber is used as far infrared heat source.
- Slide rail technology is adopted for lying down of the backrest frame to keep zero distance between backrest and wall, thus saving space to the greatest extent.
- The guide rail of the backrest frame adopts curved guide rail technology, which conforms to the back of the human body and makes people enjoy a massage from the head to the thigh.
- It is provided with an intelligent voice control recognition function (built-in voice control microphone beside the left armrest shortcut keys).
- USB charging function is provided in front of the slot for the right armrest controller.
- The left armrest is equipped with Automatic key, Voice Control Wake-up key (this key is only effective when the voice control switch in the hand controller is turned on), Calf Up key, Calf Down key, Linkage Lying key, Linkage Up key, Standby key and other shortcut keys.
- Bump massage and magnetic therapy function are provided in the left and right palm airbag pockets.

Function

- The front end of the right armrest is provided with the human health detection feature to detect the current human heart rate, blood oxygen saturation and fatigue index.
- It is provided with Thai stretch massage function: the calf and backrest are lifted to form automatic lying down in a cyclic manner. At the same time, the calf air compression and the back manipulators cooperate together to massage and the legs can be stretched for a stretch massage.
- It is provided with a separate lifting adjustment function for the calf frame, zero-gravity I and zero-gravity II automatic lying angle adjustment function and linkage lifting adjustment function for the backrest frame.
- It is provided with the sole roller massage function. A group of rollers roll to massage, with five levels of speed for adjustment.
- The calf frame is provided with a retractable adjustment function. The user uses his/her foot to push out his/her calf and foot. The length for the user to stretch out his/her foot is dependent on the length of his/her calf, and the user stretches back his/her foot by spring force. It is adapted to different people's height.
- Music playing system, with built-in 3D digital audio in the left and right upper arms. The Bluetooth function of intelligent devices can be used for wireless connection to play music.
- The left and right armrests are equipped with LED mood lights.
- Equipped with TFT color screen hand controller.
- Automatic sit-up function when the power is off and manipulator automatic re-set function.
- The head cushion adopts two independent designs, one large and one small, which can be used according to one's own needs to reduce the massage strength of the neck and shoulders; head cushion can be expanded to extend to the back to reduce the strength of back massage. It is suitable for different people to use and can be freely selected.

Introduction to the Remote Controller

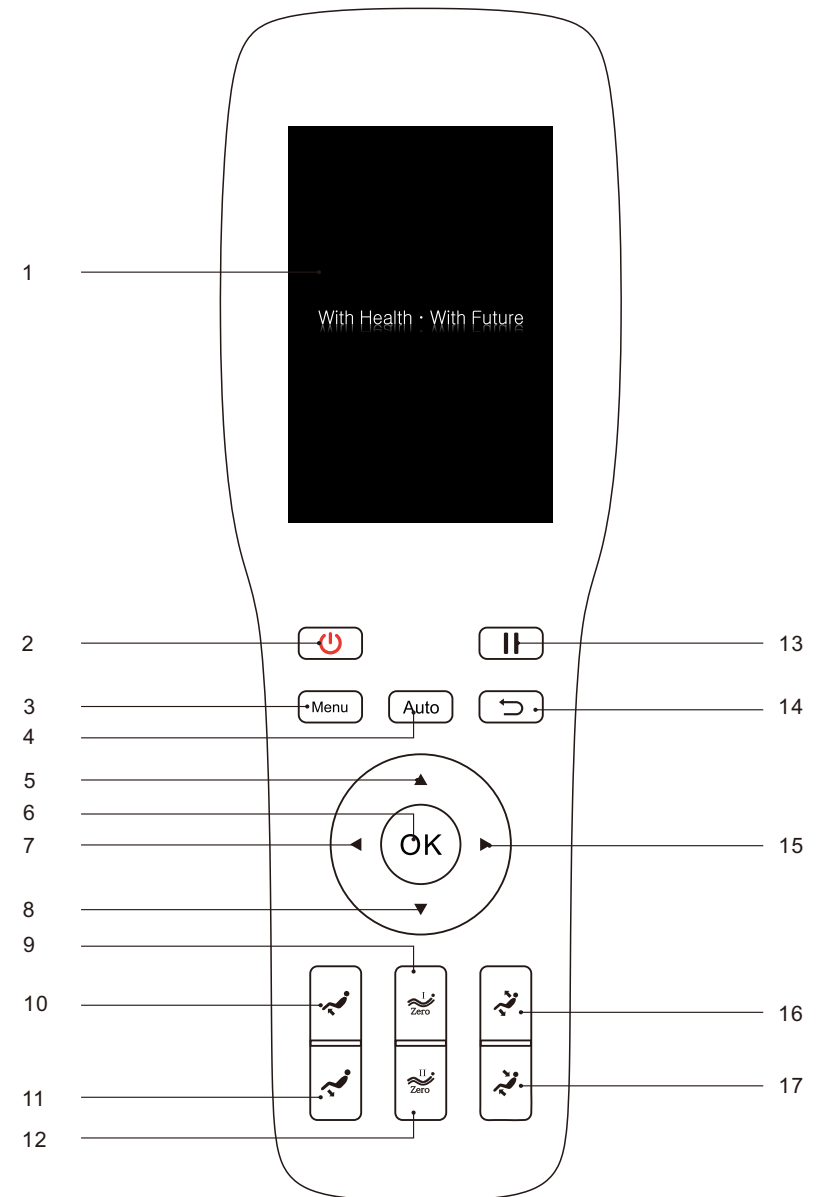

Introduction to the Remote Controller

1. Display screen:
 - TFT color liquid crystal display screen displays the massage function in the operating status.
2. Standby key:
 - Turn the massage chair on or off.
3. Menu key:
 - Enter the main menu selection interface. Please refer to page 15 of this manual for detailed function descriptions.
4. Automatic key:
 - Enter the automatic function mode selection interface. Please refer to page 16 of this manual for detailed function description.
5. Up key:
 - Navigate the Up key, select the object upward in the menu or adjust the massage position upward.
6. OK key:
 - Confirm the selected massage function to perform confirmed massage.
7. Left key:
 - Navigate the Left key, select the object to the left or enter the left menu.
8. Down key:
 - Navigate the Down key, select the object downward in the menu or adjust the massage position downward.
9. Zero-gravity I key:
 - The calf frame and backrest will be automatically adjusted to the zero-gravity I position.
10. Calf frame ascending key:
 - According to the user's own massage requirements, the calf frame is ascended to the most comfortable massage posture.
11. Calf frame descending key:
 - According to the user's own massage requirements, the calf frame is descended to the most comfortable massage posture.
12. Zero-gravity II key:
 - The calf frame and backrest will be automatically adjusted to the zero-gravity II position.
13. Pause key:
 - Pause all currently running massage functions and press this key again to continue running all massage functions before the pause.
14. Back key:
 - Return to the function information interface in the current operating status or return to the previous interface.
15. Right key:
 - Navigate the Right key to enter the sub-menu or select the object to the right.
16. Linkage sit-up key:
 - According to the desired massage angle, the backrest frame and the calf frame are adjusted for linkage sit-up at the same time to the most comfortable linkage sit-up massage posture.
17. Linkage lying key:
 - According to the desired massage angle, the backrest frame and the calf frame are adjusted for linkage lying at the same time to the most comfortable linkage lying massage posture.

Method of Usage

I. Turn on the power supply of this product:

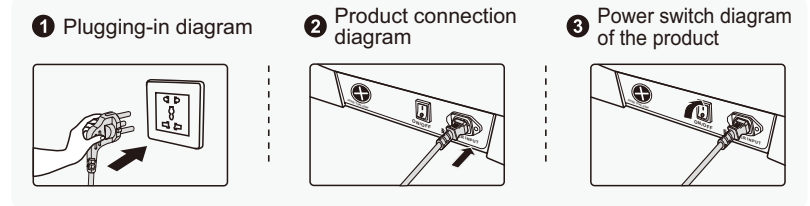

II. Massage Function Control Operation:

- After the massage chair is powered on and off and in the standby state, (LED lamp) can be awakened by the hand controller or shortcut key (LED lamp lights up), the backrest frame and calf frame can be adjusted and voice-activated awakening can be carried out and other functions cannot be used.



2. Start massage (on/off key)

- Press the on/off key, start massage, enter the startup screen, keep the backrest frame at the default position, lift the calf frame slightly, wait for any one of the automatic function programs to be selected and start to automatically detect the full body shape and shoulder position. If the automatic function is not selected within 5 minutes, the massage chair will automatically shut down.
- To select a personalized program, press the "Menu" key to enter the main menu interface, and use the navigation "Up" or "Down" key to select the "Personalized Program" function and press the "OK" key to enter the personalized program selection.

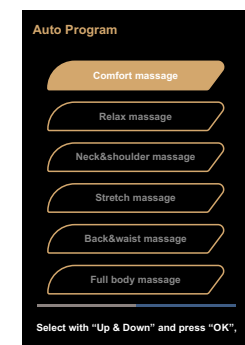

Method of Usage

1).Shoulder position and body shape detection

- After any automatic function is selected, the position of the backrest frame and calf frame will be adjusted to the set angle.
- After the angle is adjusted, the massage chair automatically enters the state of automatic detection of the body shape and shoulder position (Note: If you want to skip the detection of shoulder position and body shape, you can press the "OK" key to cancel the body shape detection and start massage).

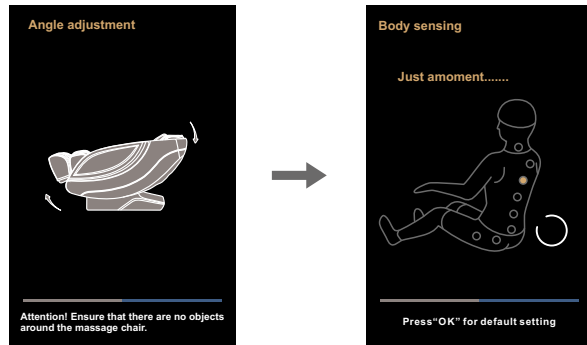

2).Shoulder position adjustment

- After detecting the shoulder position, the buzzer prompts with a "beep." If there is any difference from the actual shoulder position, adjust to the appropriate position by pressing "Up" or "Down." Shoulder position is adjustable in 11 gears. If there is no shoulder position adjustment within 10 seconds, it will automatically enter the massage function. If you press the "OK" key directly, you will enter the massage immediately. If the shoulder position cannot be detected, massage is performed at the default shoulder position height.
- Note: During massage, from the information interface, you can press "Up" key or "Down" key to select the "Shoulder Position" button, then press the "OK" key to enter the shoulder position adjustment interface, and then press "Up" key or "Down" key to adjust the shoulder position.

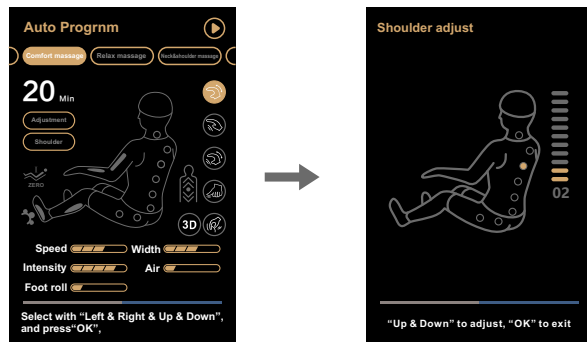

Method of Usage

Key	Description
	Move the massage balls upward to a suitable shoulder position
	Move the massage balls downward to a suitable shoulder position

- After entering the massage program, if the shoulder position needs to be adjusted from the operation status information interface, you can directly select the "Shoulder Position" key with the "Up Key" or "Down" key, then press the "OK" key to enter the shoulder position section interface, and press the "Up" key or "Down" key to adjust the shoulder position height; Press the "Back" key to return to the previous menu, or wait for 10 seconds to automatically return to the information interface.

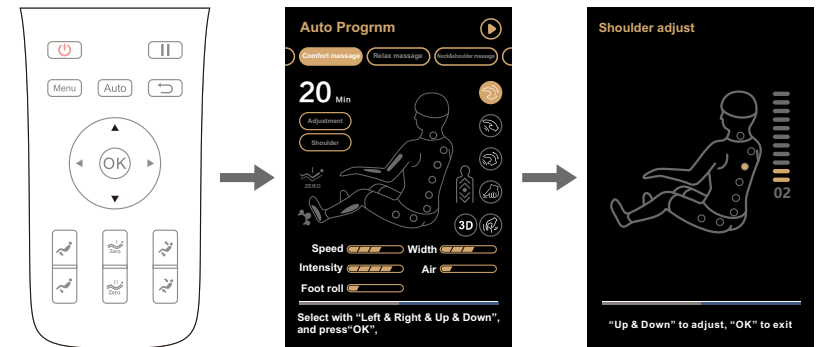

3).Adjustment

- After entering the massage program, if message position adjustment is required, press "Menu" key on the hand controller to enter the main menu interface, select the adjustment icon with "Up" key or "Down" key or "Left" key or "Right" key, press "OK" key to enter the adjustment function interface, and then press "Left" key or "Right" key to select the massage function to be adjusted.
- You can also directly press "Up" key or "Down" key to select the adjustment button from the operation status information interface, and press "OK" key to enter the adjustment interface to select the massage function to be adjusted.
- From the message position interface, if the message position is a fixed point or local, you can directly press the "Up" or "Down" key to move the manipulator up and down for adjustment.
- From the manual program interface, if the message position is not fixed point or local, you need to adjust the message position as fixed point or local, then press the "Left" key to select adjustment function and enter the message position interface, and then press the "Up" or "Down" key to move the manipulator up or down for adjustment.

Method of Usage

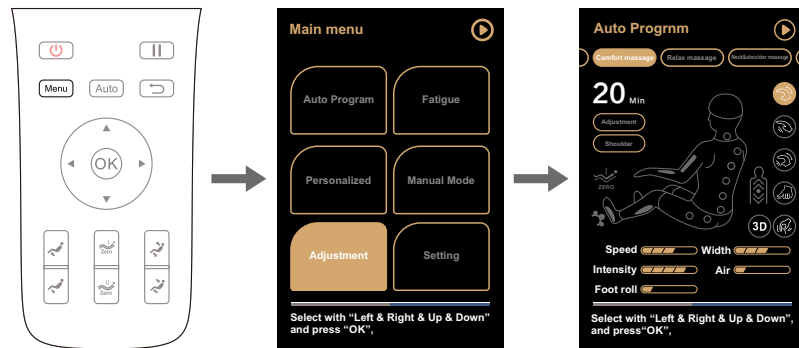

3. Pause key

- When the massage function is operating, press the "Pause" key to temporarily stop all massage functions; press the "Pause" key again to continue the massage function before the pause. If the pause lasts for more than 20 minutes, all massage functions will be automatically turned off.

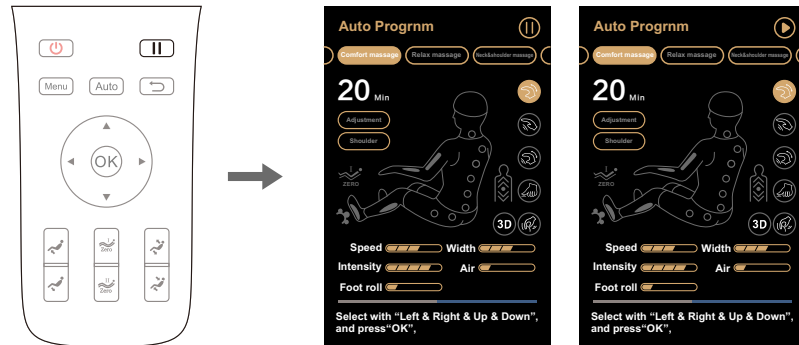

4. Menu key (main menu)

- Press the "Menu" key to enter the main menu message function selection interface, including automatic program, fatigue detection, personalized program, manual program, adjustment function, setting, etc.
- Press "Up" key or "Down" key or "Left" key or "Right" key to select the massage function, and press "OK" key to enter the massage function selected. Press "Back" key to return to the operation status information interface.

Method of Usage

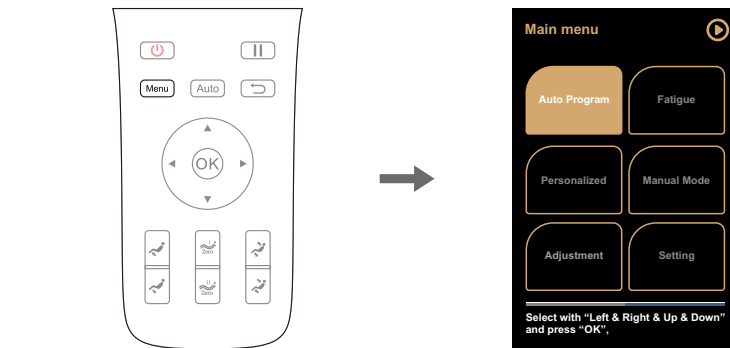

5. Manual program (main menu - automatic program)

- Press "Menu" key to enter the main menu interface, and press "Up" key or "Down" key or "Left" key or "Right" key to select the automatic program; The automatic program includes six automatic massage modes, i.e. Comfort massage, Relax massage, Neck and shoulder massage, Stretch massage, Back and waist massage and Full body massage; Note: You can directly press the "Automatic" key to enter the automatic program interface.
- Press "Up" or "Down" key to select any of automatic massage functions, and press "OK" key to enter the automatic massage function selected. Press "Back" key to return to the operation status information interface.

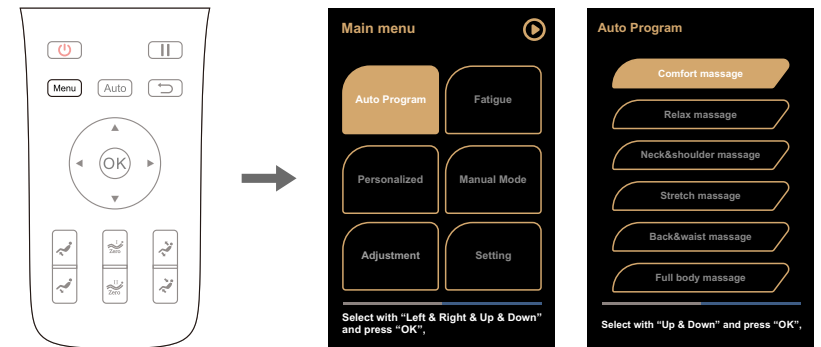

Method of Usage

Function	Description
Comfort massage	The most comfortable massage experience.
Relax massage	Gentle and comfortable deep massage, which can relieve body fatigue and relax the body.
Neck& shoulder massage	According to the unique neck and shoulder massage method, through effective massage of cervical spine and scapula, neck and shoulder pain can be relieved and neck and shoulder fatigue can be improved.
Stretch massage	The calf frame and the backrest frame are lifted and lowered for stretching and traction of the calf and waist, effectively relieving tiredness, relieving joint soreness and restoring vitality.
Back& waist massage	Focus on the back and waist to relieve back and waist soreness.
Full body massage	Deep massage, which can revive body vitality.

Note: If the automatic function has been selected and used, it will be displayed in the status bar of massage function. You can directly press the "Back" key to view it

6. Fatigue detection (main menu - fatigue detection)

- Press the "Menu" key to enter the main menu screen, press the "Up" key or "Down" key or "Left" key or "Right" key to select the fatigue detection icon, and press the "OK" key to pop out the fatigue detection box. At this time, do not place your finger on the fatigue detection sensor or it cannot detect.
- After entering the fatigue detection box, press the "Left" or "Right" key to select the "Yes" menu in the box and then press the "OK" key to start the fatigue detection. At this time, the finger pulp can be placed on the fatigue detection sensor and the finger should be still and not move. The fatigue detection can be completed in about 40-60 seconds and the currently measured heart rate, blood oxygen saturation and fatigue index can be displayed in the pop-up box. After 10 seconds, the system recommends executing the corresponding fatigue recovery automatic program according to the detected human body fatigue index (you can also press the "Right" key to select the "No" menu in the box, and then press the "OK" key to skip the fatigue recovery automatic program and continue to run the

Method of Usage

normal massage program). If the human body is detected to be free from fatigue, the normal massage program will run.

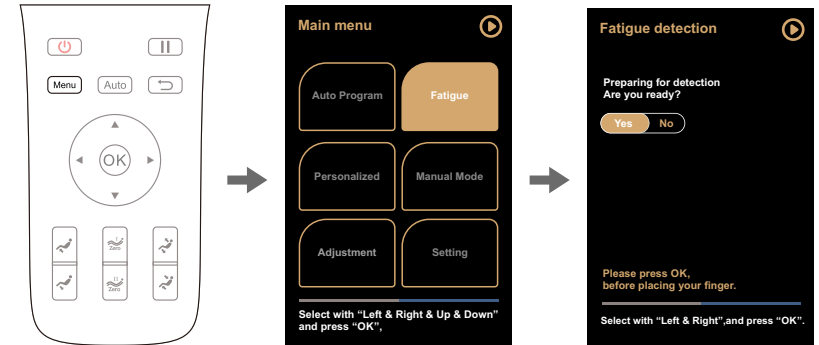

- After the fatigue detection is completed, select "Yes" or "No" again to select the exclusive massage program and then press the "OK" key to confirm. Press the "Back" key to return to the previous menu interface.
- If the fatigue detection is unsuccessful, you can select "Yes" again to start the re-detection or select "No" to cancel the fatigue detection.

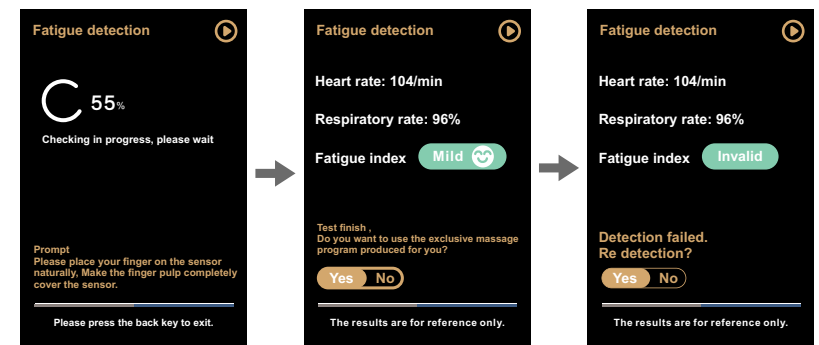

Note: During the detection, you cannot move or press down hard. The body should be in a relaxed state. Otherwise, the detection data may be inaccurate.

Method of Usage

7. Personalized program (main menu - personalized program)

- Press "Menu" key to enter the main menu interface and press "Up" key or "Down" key or "Left" key or "Right" key to select the personalized program; under the personalized program, there are four personalized massage modes: Massage shoulder, Massage the back, Massage waist and buttocks and Massage legs and feet.
- Press "Up" or "Down" key to select any of personalized massage functions and press "OK" key to enter the personalized massage function selected. Press "Back" key to return to the operating status information interface.

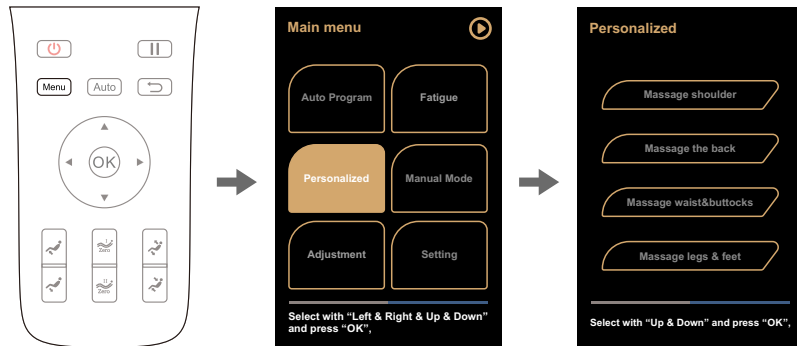

Function	Description
Massage shoulder	Massage neck and shoulders with various techniques such as kneading and kneading and tapping.
Massage the back	Massage with massage, tapping and other techniques, mainly on the back, sometimes on the shoulders and waist.
Massage waist& buttocks	Massage the waist and buttocks with kneading and tapping.
Massage legs & feet	Wrap feet with an airbag + sole roller and massage the legs and feet with a calf airbag.

Method of Usage

8. Manual program (main menu - manual program)

- Press the "Menu" key to enter the main menu interface, press the "Up" key or "Down" key or "Left" key or "Right" key to select the manual program and press the "OK" key to enter the manual program interface.
- Manual program: including massage technique, massage position, air compression and other massage functions.
- After entering the manual program interface, press the "Left" or "Right" key to select the sub-menu to the left or to the right and press the "Up" or "Down" key to select the desired massage function option, and press the "OK" key to confirm; press the "Back" key to return to the operation status information interface.

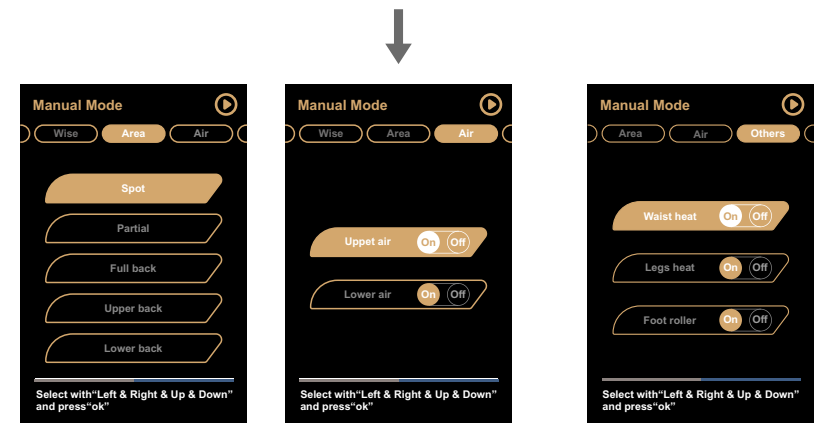
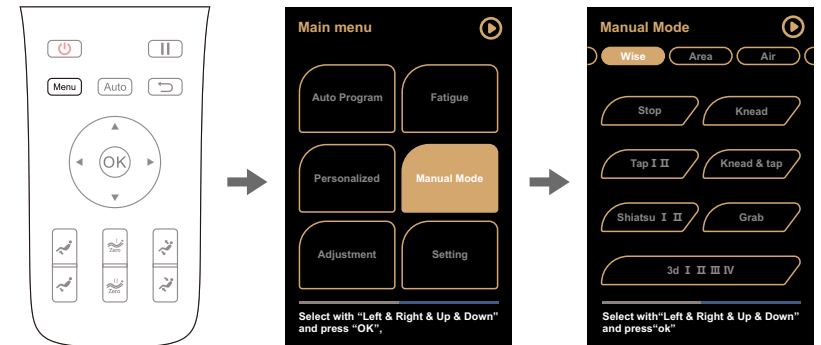

Method of Usage

1).Manual program (main menu - massage technique)

- It is provided with manual massage techniques: including 11 manual massage techniques, i.e., Stop, Knead, Tap I, Tap II, Knead and Tap, Shiatsu I, Shiatsu II, Grab, 3D I, 3D II, 3D III and 3D IV.
- After entering the manual function interface, press "Up" key or "Down" key to select the desired manual massage technique, press "OK" key to confirm (there are seven modes of kneading, press "OK" key to switch in cycles), and the information interface will not be automatically returned after the technique is selected. Press the "Back" key to return to the previous level interface. After returning to the information interface, you will find that you have entered the information interface with manual function.

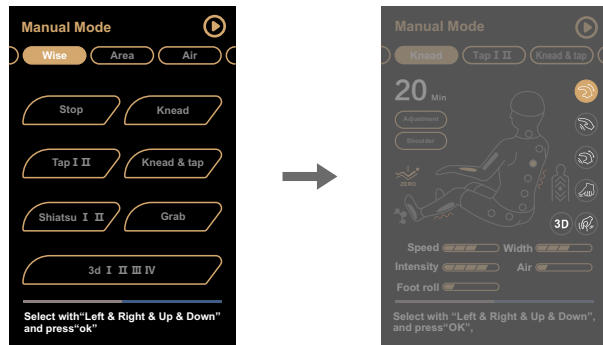

Function	Massage ball adjustment	
Kneading	Speed.	Five levels of speed for adjustment Five levels of width for adjustment Five levels of 3D massage intensity for adjustment
Tapping	Speed and width.	
Kneading and tapping	Speed.	
Shiatsu	Speed and width.	
Grab	Speed.	
3D	Speed, width and intensity.	

Note:

1. In 3D massage technique mode, the width cannot be adjusted for 3D I and 3D II;
2. Air compression force and massage intensity are adjusted by decreasing cycle.

Method of Usage

2).Manual program (main menu - massage position)

- Manual massage position: including Spot, Partial, Full, Upper, Lower, etc.
- After entering the manual program interface, press the "Left" key or "Right" key to select the massage position function sub-menu. Then press the "Up" or "Down" key to select the desired massage position function option, and press the "OK" key to confirm; press the "Back" key to return to the operating status information interface.

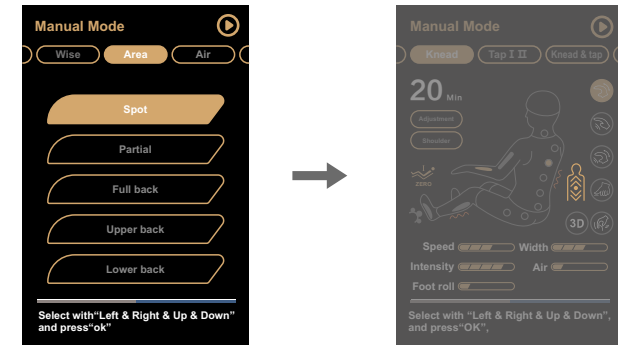

Function	Description	
Fixed point	Fixed-point massage at fixed-point position.	When selecting fixed-point and local massage positions, adjust the massage position by "Up" key or "Down" key of "massage position" in the "adjustment function."
Local	Small-scope local massage back and forth.	
Full back	Full back massage back and forth	
Upper back	Upper back massage back and forth	
Lower back	Lower back massage back and forth	

Method of Usage

3).Manual program (main menu - air compression)

- Manual air compression massage: including upper body air compression and lower body air compression.
- After entering the manual program interface, press the "Left" key or "Right" key to select the air compression massage function sub-menu. Then press "Up" or "Down" key to select the desired air compression massage function option, and press "OK" key to turn on or off the air compression massage function; Press "Back" key to return to the operation status information interface.

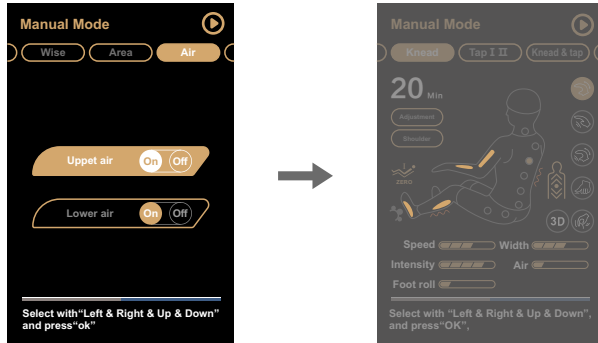

Function	Description
Upper body air compression	Turn on/off the upper body air compression function.
Lower body air compression	Turn on/off the lower body air compression function.

4).Manual program (main menu - other)

- Other manual functions: including waist heating function, leg heating function and sole roller function.
- After entering the manual program interface, press "Left" key or "Right" key to select other function sub-menus. Then press "Up" or "Down" key to select the desired other massage function option, and press "OK" key to turn on or off the selected massage function; press "Back" key to return to the operation status information interface.

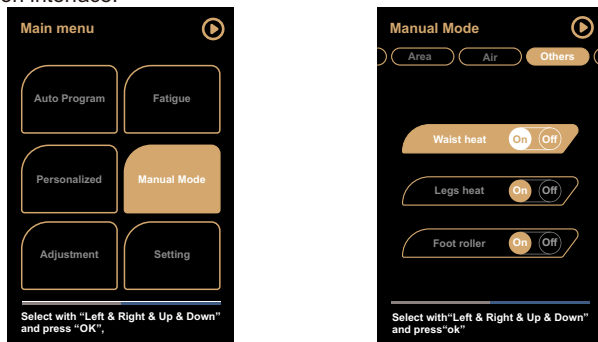

Method of Usage

01). Manual program (other - waist heating function)

- Waist heating function: It will be warm after turning on the heating function for 3 minutes.
- After entering the manual program interface, press "Left" key or "Right" key to select other function sub-menus. Then press "Up" or "Down" key to select the waist heating function option, and press "OK" key to turn on or off the waist heating function; press "Back" key to return to the operation status information interface.



02). Manual program (other - calf heating function)

- Leg heating function: It will be warm after turning on the heating function for 3 minutes.
- After entering the manual program interface, press "Left" key or "Right" key to select other function sub-menus. Then press "Up" or "Down" key to select the leg heating function and press "OK" key to turn on or off the leg heating function; press "Back" key to return to the operating status information interface.

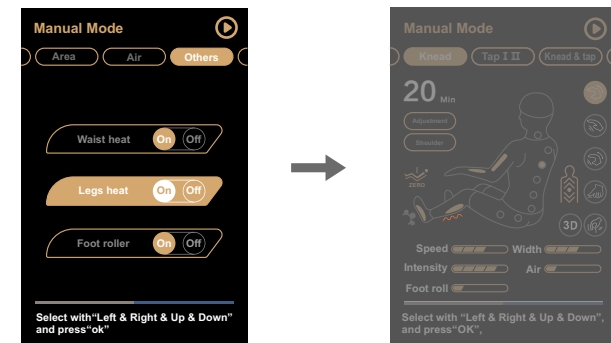

Method of Usage

03). Manual program (other - sole roller)

- Sole roller function: with five levels of speed for adjustment.
- After entering the manual program interface, press "Left" key or "Right" key to select other function sub-menus. Then press "Up" or "Down" key to select the sole roller function option and press "OK" key to turn on or off the sole roller function; press "Back" key to return to the operation status information interface.

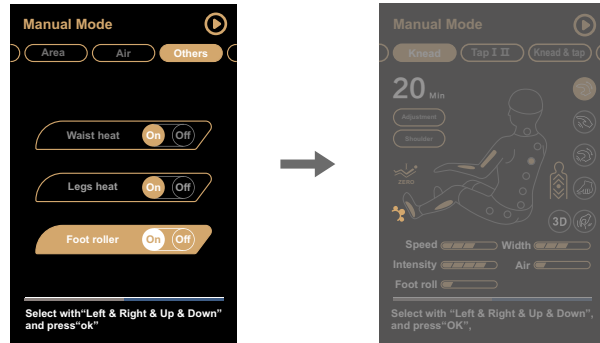

9. Adjustment function (main menu - adjustment function)

- Press the "Menu" key to enter the main menu interface, press the "Up" key or "Down" key or "Left" key or "Right" key to select the adjustment function and press the "OK" key to enter the adjustment function interface.
- Adjustment function: including adjustment functions such as massage parameters, massage position and other.
- After entering the adjustment program interface, press the "Left" or "Right" key to select the sub-menu to the left or to the right and press the "Up" or "Down" key to select the massage function option to be adjusted, and press the "OK" key to confirm; press the "Back" key to return to the operating status information interface.

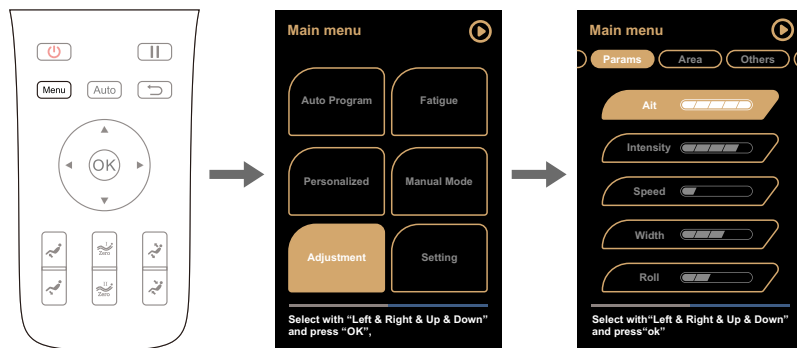

Method of Usage

1). Adjustment function (massage parameters)

- Adjustment function (massage parameters): including air compression force, massage intensity, massage speed, massage width and roller speed.
- After entering the adjustment function interface, press the "Left" key or "Right" key to select the massage parameters sub-menu. Then press the "Up" or "Down" key to select any of the massage parameters, and press the "OK" key to adjust the speed, width or intensity; press the "Back" key to return to the operating status information interface.

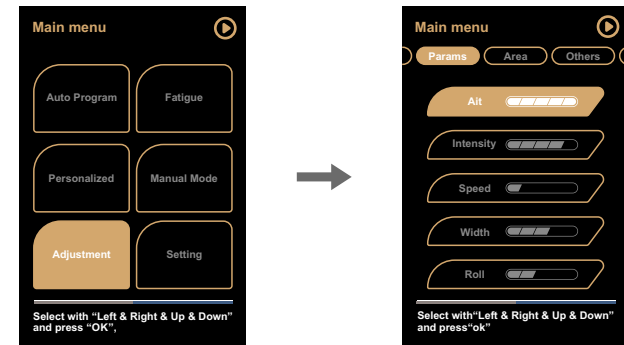

- Air compression force: five levels of intensity for adjustment.
- Massage intensity: five levels of ejection intensity of the massage machine core for adjustment.
- Massage speed: five levels of massage speed for adjustment.
- Massage width: the width can be adjusted under the massage techniques including tapping, shiatsu and knocking, with five levels for adjustment.
- Roller speed: five levels of speed for adjustment.

2). Adjustment function (massage position)

- Adjustment function (massage position): in the state of fixed point or local massage area.
- After entering the adjustment function interface, press the "Left" key or "Right" key to select the massage position sub-menu. Press and hold the "Up" key and do not release the massage manipulator to walk up; if it is released, it will stop; press and hold the "Down" key and do not release the massage manipulator to walk down. If it is released, it will stop. Press "Back" key to return to the operating status information interface.

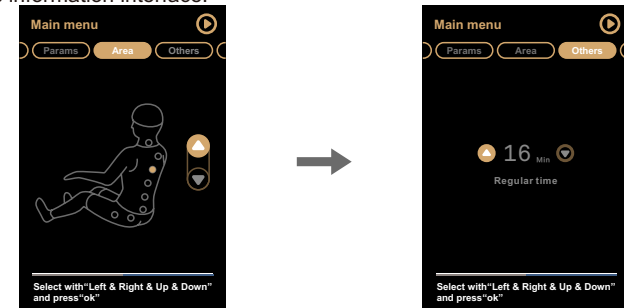

Method of Usage

3).Adjustment function (other)

- Adjustment function (other), the time for each adjustment is increased by 5 minutes, with a minimum of 5 minutes and a maximum of 40 minutes, cycling in turn.
- After entering the adjustment function interface, press the "Left" key or "Right" key to select other sub-menus. Press "Up" or "Down" key to adjust the time and press the "Back" key to return to the operating status information interface.

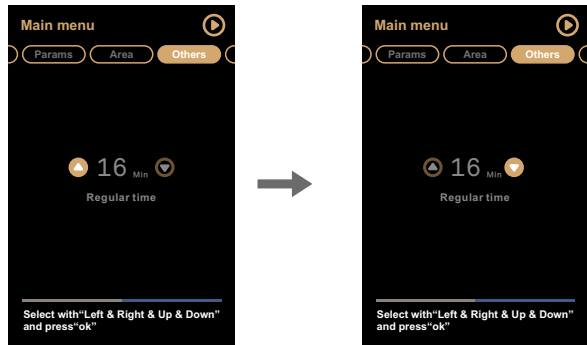

10.Setting (main menu - setting)

- Press the "Menu" key to enter the main menu interface, press the "Up" key or "Down" key or "Left" key or "Right" key to select the setting program and press the "OK" key to enter the setting program interface.
- Setting program: including language, screen locking, intelligent voice control, equipment and other setting functions.
- After entering the adjustment program interface, press the "Left" or "Right" key to select the sub-menu to the left or to the right and press the "Up" or "Down" key to select the function option to be set, and press the "OK" key to confirm; press the "Back" key to return to the operating status information interface.

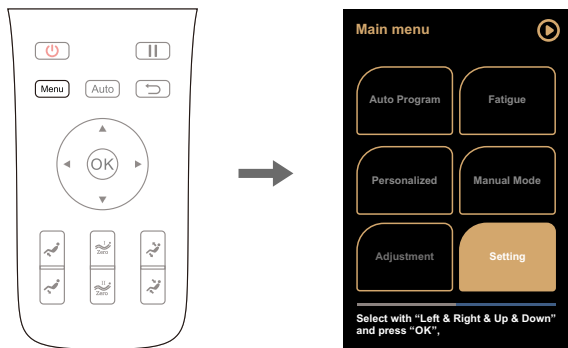

Method of Usage

1).Setting (language)

- Setting (language): including Simplified Chinese and English.
- After entering the setting function interface, press the "Left" key or "Right" key to select the language sub-menu. Then press the "Up" or "Down" key to select the language, and press the "OK" key to confirm; press the "Back" key to return to the operation status information interface.



2).Setting (screen locking)

- Setting (screen locking): The screen locking time can be adjusted for 1-20 minutes, and the screen locking time can be increased by 1 minute, 2 minutes, 3 minutes, 4 minutes and 5 minutes in turn and can be increased to 20 minutes at most.
- After entering the setting function interface, press the "Left" key or "Right" key to select the screen locking sub-menu. Press "Up" or "Down" key to select screen locking time, and press "Back" key to return to the operation status information interface.

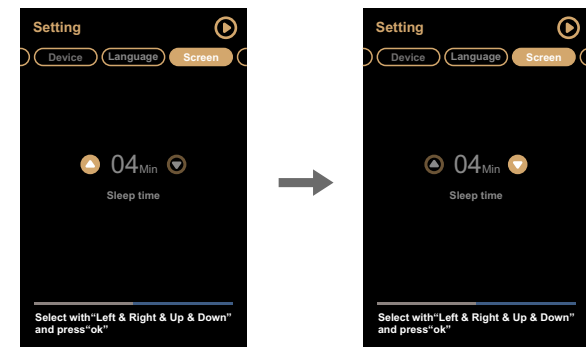

Method of Usage

3).Setting (intelligent voice control)

- Setting (intelligent voice control): intelligent voice control massage chair.
- After entering the setting interface, press "Left" key or "Right" key to select the intelligent voice control sub-menu and press "OK" key to turn the intelligent voice control function on or off. Press "OK" key to confirm; press "Back" key to return to the operating status information interface.

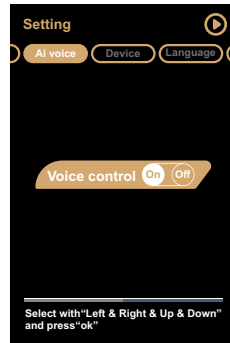

4).Setting (equipment information)

- After entering the setting function interface, press "Left" key or "Right" key to select the equipment information sub-menu to display the current equipment information, and press "OK" key to confirm. Press "Back" key to return to the operating status information interface.

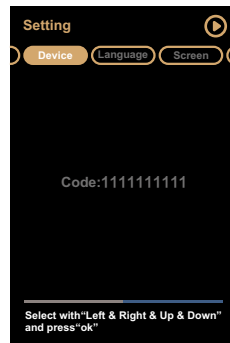

11.Back key

- When adjusting the massage function, if you need to return to the main interface, press this key to return to the operating status information interface.

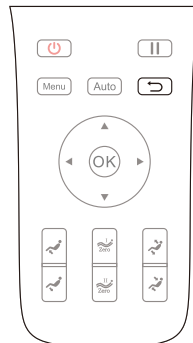

Method of Usage

12.Zero-gravity key

- Press the "Zero-gravity key" to activate the zero gravity adjustment function, and you can select "Zero-gravity I" or "Zero-gravity II" position according to your own needs

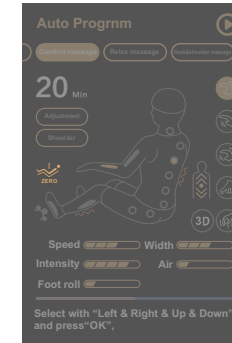

Key	Description
	Zero-gravity I: the calf frame and backrest will be automatically adjusted to the zero-gravity I position.
	Zero-gravity II: the calf frame and backrest will be automatically adjusted to the zero-gravity II position.

13.Lying angle adjustment key





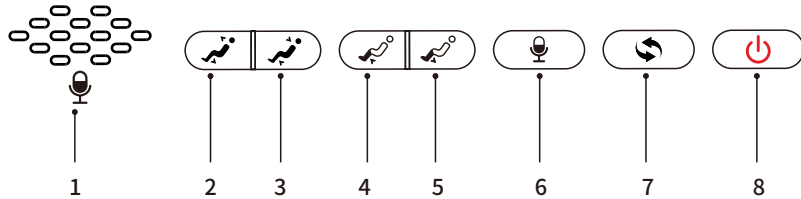

Key	Description
	Calf frame ascending key: press and hold this key to slowly raise the calf frame and release it to stop rising.
	Calf frame descending key: press and hold this key to slowly lower the calf frame and release it to stop lowering.
	Linkage sit-up key: press and hold this key to slowly rise the backrest frame while slowly lowering the calf frame and release it to stop rising of the backrest frame and lowering of the calf frame.
	Linkage lying key: press and hold this key to slowly lower the backrest frame while slowly rising the calf frame and release it to stop lowering of the backrest frame and rising of the calf frame.

Method of Usage

III. Description of armrest shortcut keys



1. Voice Control Microphone: built-in voice control microphone.
2. Linkage Sit-up key: adjust the linkage up angle.
3. Linkage Lying key: adjust the linkage lying angle.
4. Calf Frame Up key: adjust calf frame up.
5. Calf Frame Down key: adjust calf frame down.
6. Voice Control Wake-up key: Short press this key to wake up the voice control, long press for 3 seconds to turn on/off the voice control function.
7. Auto key: switch from/to the automatic message function in cycles.
8. On/Off key: turn on/off the message chair.

Key	Description
	On/Off key: turn on/off the message chair.
	Linkage Sit-up key: press and hold this key to slowly raise the backrest frame while slowly lowering the calf frame and release it to stop rising of the backrest frame and lowering of the calf frame.
	Linkage Lying key: press and hold this key to slowly lower the backrest frame while slowly rising the calf frame and release it to stop lowering of the backrest frame and rising of the calf frame.
	Calf Frame Ascending key: press and hold this key to slowly rise the calf frame, and release it to stop rising.
	Calf Frame Descending key: press and hold this key to slowly lower the calf frame and release it to stop lowering.
	Voice Control Wake-up key: short press this key to wake up the voice control function, long press for 3 seconds to turn on/off this function. If no valid voice words are identified within 10 seconds, it is necessary to wake up the voice control function again (this key is only enabled when the voice control switch is on).
	Auto Mode key: switch from/to the automatic message function for each press.

Method of Usage

IV. Voice Control Mode

- When the massage chair is turned on or in standby mode, the sound "Hi Alice" or "Hey Alice" will be produced to enable the voice control function. Alternatively, you can press the voice control button on the right armrest to enable the voice control function.
- Long press 3 seconds to turn on or off the voice control function.
- After such function is enabled successfully, the massage chair will reply "I am here". At this moment, once a corresponding voice control entry to be implemented is given within six seconds, the corresponding voice control function can be performed after a reply is received from the massage chair; if no correct voice control entry is given within six seconds, the voice control function automatically will be off automatically and needs to be enabled again.
- Note: When the voice control function is enabled, please speak English. The speaking speed cannot be too fast. The speech instruction should be issued according to the voice control entry.

Voice Control Entry		
Entry: "Hi Alice" or "Hey Alice". Answer: I am here.		
No.	Voice control entry	Answer entry
1	Massage on	Answer: Ok, massage on
2	Massage close	Answer: Ok, massage close
3	Comfort Massage	Answer: Ok, comfort massage
4	Relax massage	Answer: Ok, relax massage
5	Full body massage	Answer: Ok, full body massage
6	Neck and shoulder massage	Answer: Ok, neck and shoulder massage
7	Back and waist massage	Answer: Ok, back and waist massage
8	Stretch massage	Answer: Ok, stretch massage
9	Fixed massage	Answer: Ok, fixed massage
10	Change the other mode	Answer: Ok, change the other mode
11	Go little down	Answer: Ok, go little down
12	Go little up	Answer: Ok, go little up
13	Open the air pressure	Answer: Ok, open the air pressure
14	Close the air pressure	Answer: Ok, close the air pressure
15	Up the seat position	Answer: Ok, up the seat position
16	Down the seat position	Answer: Ok, down the seat position
17	Stop adjustment	Answer: Ok, stop adjustment

Method of Usage

V. Turn off the power and stop massage

- If the power button is pressed during massage, it will stop all the massage functions immediately, and the backrest, the legrest and massage chair manipulators will go back to the default positions. When the preset massage time is up, all the massage functions will be off. The backrest and the legrest will not go back to the default positions.
- Shut off the power supply of this product, as shown in the attached figure (Power Shut-off Diagram of the Product).

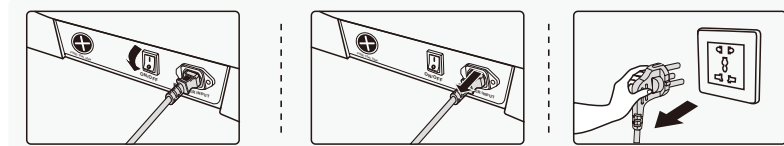

- 1 Schematic diagram of the whole machine power turning off.
- 2 Schematic diagram of unplugging the whole machine wiring.
- 3 Schematic diagram of unplugging the power plug.

VI. Operation Instructions for Bluetooth Speaker Play

1. Enter the smart device main menu. Open "Settings" and select the "Bluetooth" option. Open "Bluetooth", and Bluetooth will automatically "Search for a New Bluetooth Device".
2. The smart device will search for the corresponding Bluetooth model (e.g. IMCM-XXXX). Click the "Match" button. If you are asked whether to match with the device, you just select "Match" to complete matching.
3. Turn on "Music Player" in the smart device and select the song to play.

VII. Installation Instructions for Legrest

- After connecting the calf and the air tube on the massage chair with the wire harness, untie the fixed pipeline belt and insert the connecting part into the seat frame (Figure 1).
- Place the round tubes on the left and right sides of the calf on the calf frame seat (Figure 2).

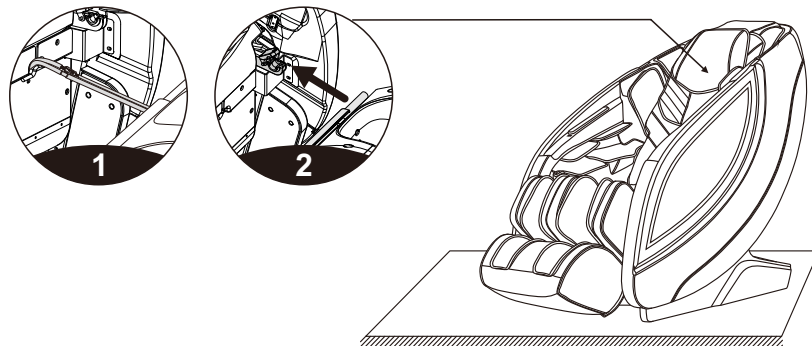

Method of Usage

- Turn over the calf fixing cover to cover the round tubes on both sides of the calf (Figure 3).
- Fasten the calf on the massage chair with 2 M4 screws (1 on the left and 1 on the right). Check whether or not there is any abnormality in the up-and-down turning and whether the pipeline is folded. The calf installation is now complete (Figure 4).

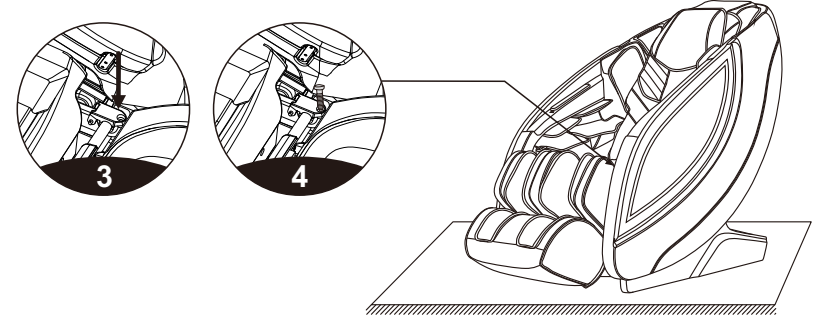

VIII. Instructions for Removal and Use of Head Cushion and Backrest

- The use of the head cushion can reduce the intensity of kneading massage on the neck and shoulders. You can decide whether to use the head cushion according to your own needs (the head cushion is recommended). The backrest and the back cushion are connected by a zipper (1). The head cushion and the backrest are connected by a zipper (2).

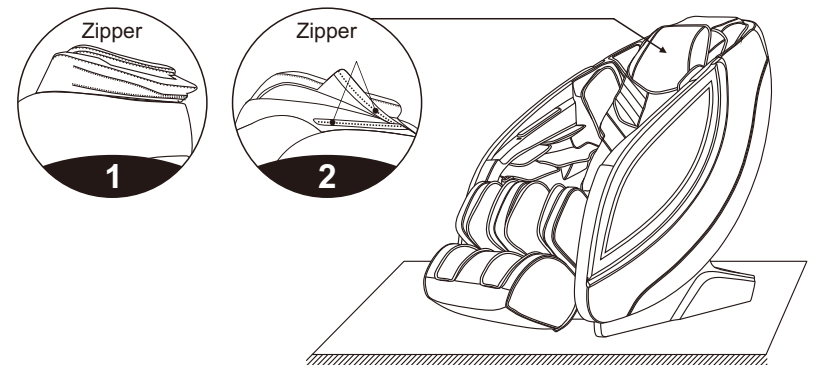

Method of Usage

IX. Floor Protection

- The prolonged heavy pressure on the massage chair may cause scratches on the floor. Thus, put a carpet or cushion on the floor where the massage chair is placed to avoid this damage.

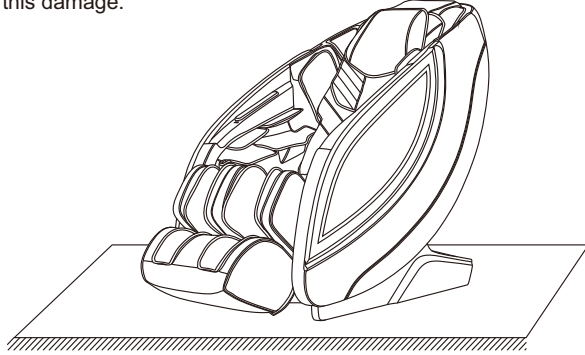

Note: Do not move the massage chair with its wheels on the rough ground or in a narrow space. At least two persons are required to lift it. During lifting, take the legrest sealing plate and backrest cover grooves as the acting points. (Do not lift the armrest directly.)

X. Instruction for movement

- Make sure that all the wires are pulled away from the massage chair surface; then press the backrest down to a certain angle (with the center of gravity resting on the wheels), you can push the massage chair forward with hands, move it to a suitable position and gently restore it to the normal angle. (Note: During movement, you must turn off the power button first and then unplug the power cord and the remote controller connection wire.)

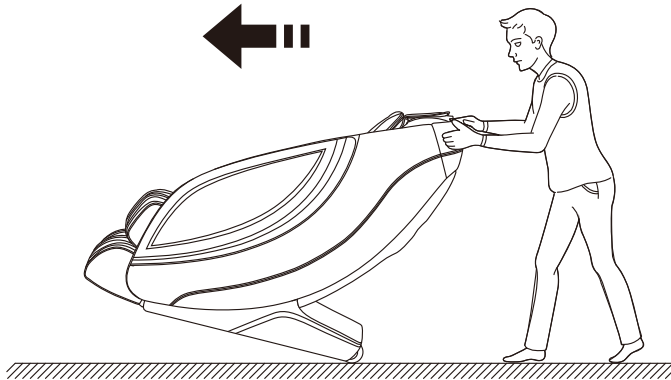

Warning : The rear moving wheels of the massage chair are only suitable for short-distance and slow movement. For long-distance transportation, please use other auxiliary moving tools to move this massage chair!

Product Specification

Model: Titan Pro - 3D Cascade

Name: Massage Chair

Rated voltage: 110-120V~ 60Hz
 220-240V~ 50Hz/60Hz

Rated power: 150W

Rated time: 20min

Safety structure: Class I

Material description: PVC, PA, steel parts, electric and electron components

MATERIAL	PU	LEATHER	CLOTH	WOOD