

SPECIFICATIONS

CASTRO

Concrete Farmhouse Sink

BO-CC30S-00-DG (DARK GREY)

BO-CC30S-00-G (GREY)

BO-CC30S-00-N (NATURAL)

PRODUCT DETAILS

- 30" x 18" x 10 1/4"
- Ø 3 1/2" drain opening
- Net Weight: 122 lbs
- Net Weight: 130 lbs
- Sealed with impermeable sealer
- Handcrafted from concrete

INSTALLATION

- Undermount
- Apron Front

STANDARDS COMPLIANCE

- UPC/cUPC compliant

IMPORTANT

Do NOT use tape or other adhesives on concrete surface as it may remove the sealer. Please see proper care instructions.

Due to the handcrafted nature of this product, it will vary in finish, texture, hammering, and other details. Dimensions may vary up to 1/4".

We strongly recommend waiting for the actual product before making any installation cuts.



TOP VIEW

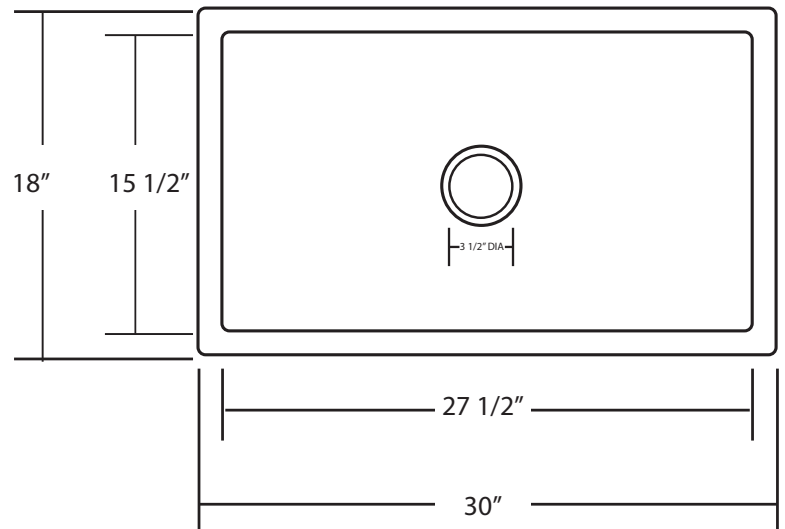

SIDE VIEW

