

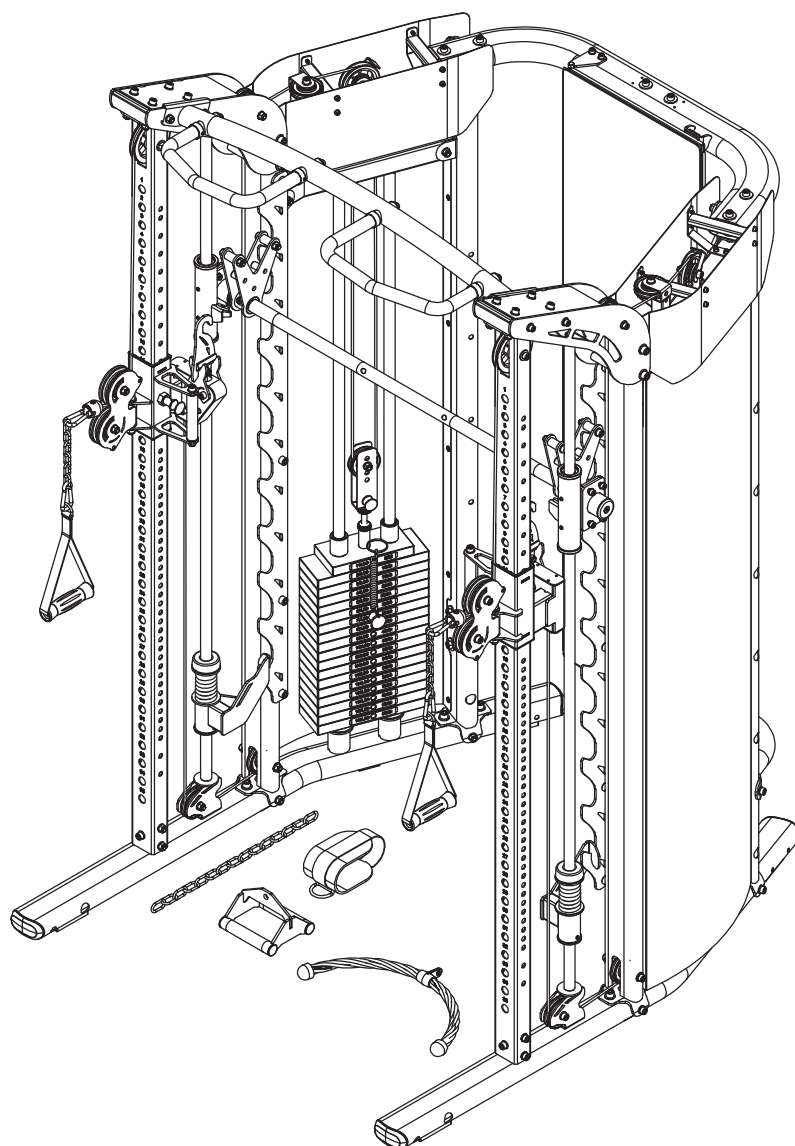

# JACKED UP FITNESS

## ASSEMBLY MANUAL

## JUF-PR5



### CAUTION!

Read all precautions and instructions in this manual before using this equipment.

20230717-V1.0

---

## TABLE OF CONTENTS

BEFORE YOU BEGIN.....	1
IMPORTANT SAFETY NOTICES.....	2
HARDWARE PACK.....	6
ASSEMBLY INSTRUCTIONS.....	9
EXPLODED DIAGRAM.....	30
PARTS LIST.....	31

---

## BEFORE YOU BEGIN

Thank you for selecting the JUF-PR5. For your safety and benefit, read this manual carefully before using the machine. As a manufacturer, we are committed to provide you complete customer satisfaction.

## **IMPORTANT SAFETY NOTICE**

### **PRECAUTIONS**

This exercise machine is built for optimum safety. However, certain precautions apply whenever you operate a piece of exercise equipment. Be sure to read the entire manual before you assemble or operate your machine. In particular, note the following safety precautions:

1. **Keep children and pets away from the machine at all times. DO NOT leave children unattended in the same room with the machine.**
2. Only one person at a time should use the machine.
3. If the user experiences dizziness, nausea, chest pain, or any other abnormal symptoms, STOP the workout at once. CONSULT A PHYSICIAN IMMEDIATELY.
4. Position the machine on a clear, leveled surface. DO NOT use the machine near water or outdoors.
5. Keep hands away from all moving parts.
6. Always wear appropriate workout clothing when exercising. DO NOT wear robes or other clothing that could become caught in the machine. Running or aerobic shoes are also required when using the machine.
7. Use the machine only for its intended use as described in this manual. DO NOT use attachments not recommended by the manufacturer.
8. Do not place any sharp object around the machine.
9. Disabled person should not use the machine without a qualified person or physician in attendance.
10. Before using the machine to exercise, always do stretching exercises to properly warm up.
11. Never operate the machine if the machine is not functioning properly.

**WARNING: BEFORE BEGINNING ANY EXERCISE PROGRAM, CONSULT YOUR PHYSICIAN. THIS IS ESPECIALLY IMPORTANT FOR INDIVIDUALS OVER THE AGE OF 35 OR PERSONS WITH PRE-EXISTING HEALTH PROBLEMS. READ ALL INSTRUCTIONS BEFORE USING ANY FITNESS EQUIPMENT. WE ASSUME NO RESPONSIBILITY FOR PERSONAL INJURY OR PROPERTY DAMAGE SUSTAINED BY OR THROUGH THE USE OF THIS PRODUCT.**

**SAVE THESE INSTRUCTIONS.**

**Assembled Dimension: 1320mm x 1530mm x 2180mm**

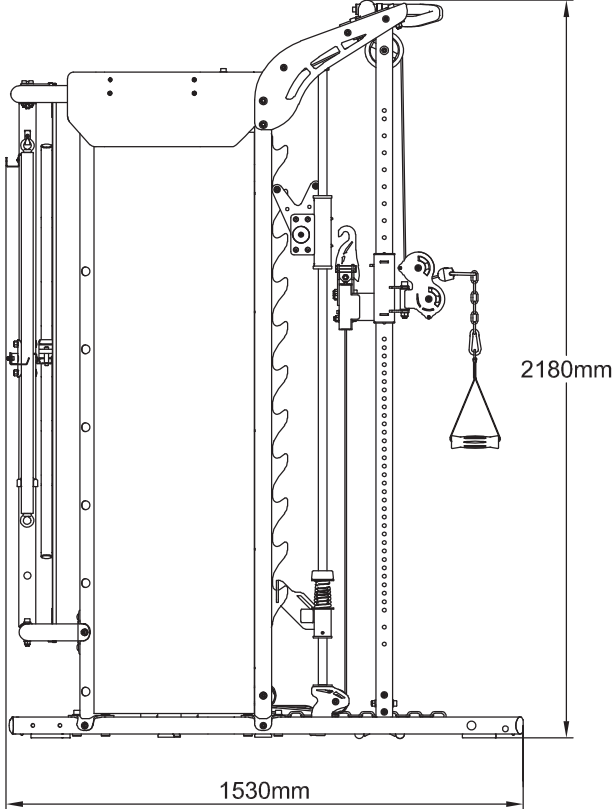
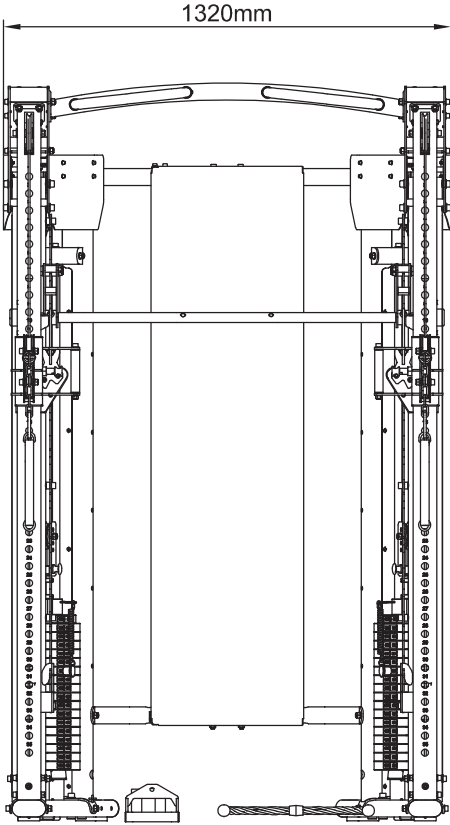



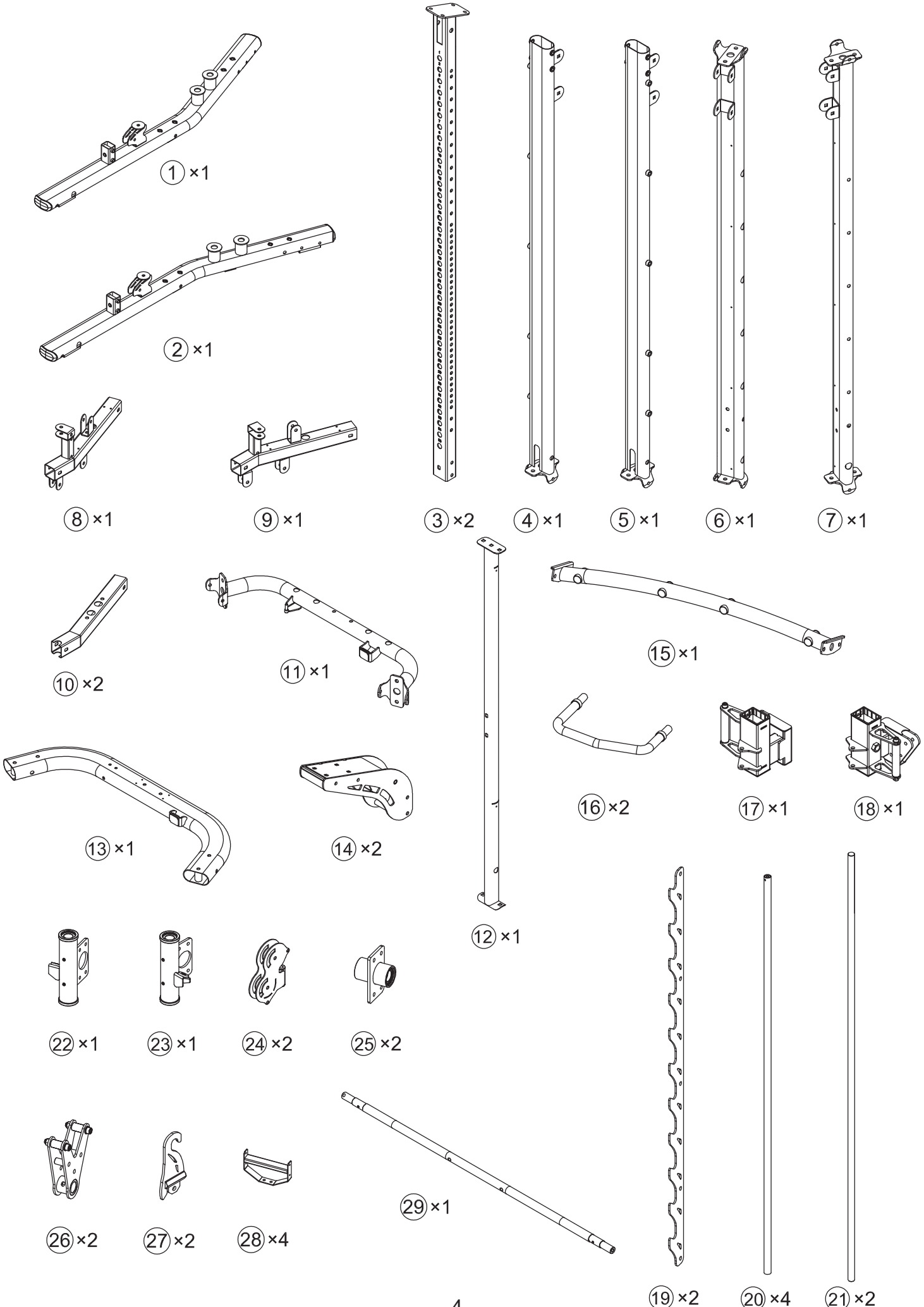

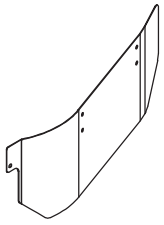

30×1

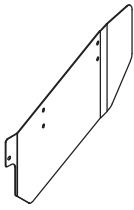

31×1

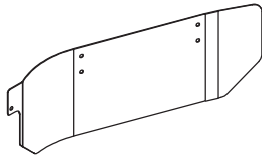

32×1

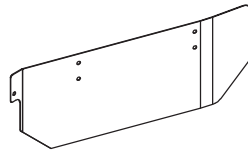

33×1

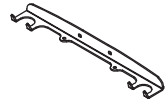

35×1



37×1



40×1



41×2



42×4



43×2



45×2



46×2



47×2



49×2

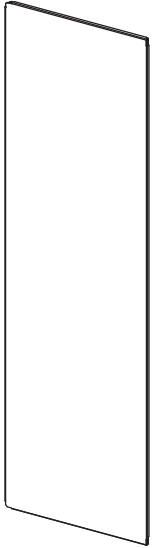

34×1



38×1

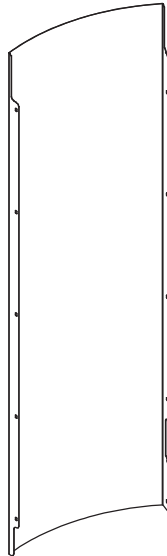

39×1

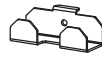

58×1



60×2

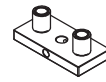

62×2

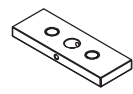

63×34



64×2



61×2



67×1



68×1



69×6



72×2



73×6



74×14



75×4

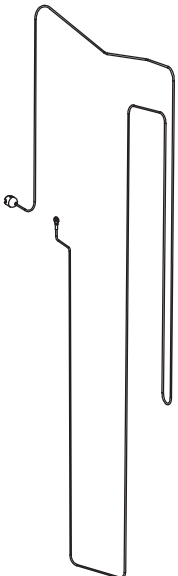

54×2



65×1

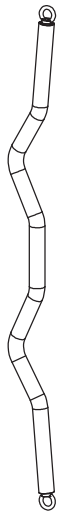

66×1



138×1



76×2



79×2



81×2



82×1

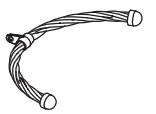

83×1



80×1



84×4



93×2



113×2



135×1



136×1



137×2

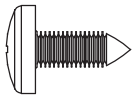

92 × 25

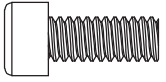
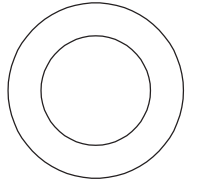
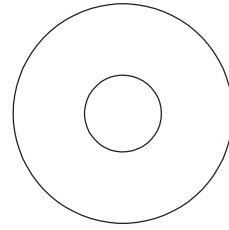
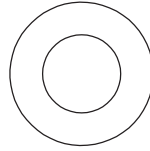
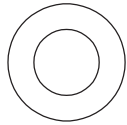

96 × 32

120 × 32

121 × 20

122 × 132

123 × 14

124 × 20

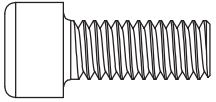

99 × 2

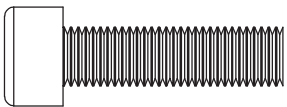
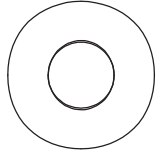
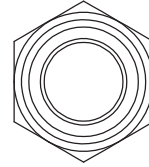
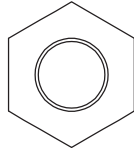
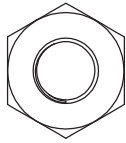

100 × 8

125 × 10

126 × 76

127 × 2

128 × 2

129 × 2



101 × 2



134 × 2

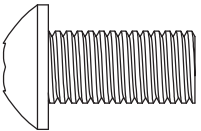

102 × 4

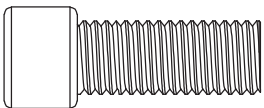

103 × 4

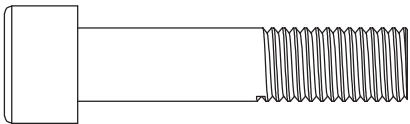
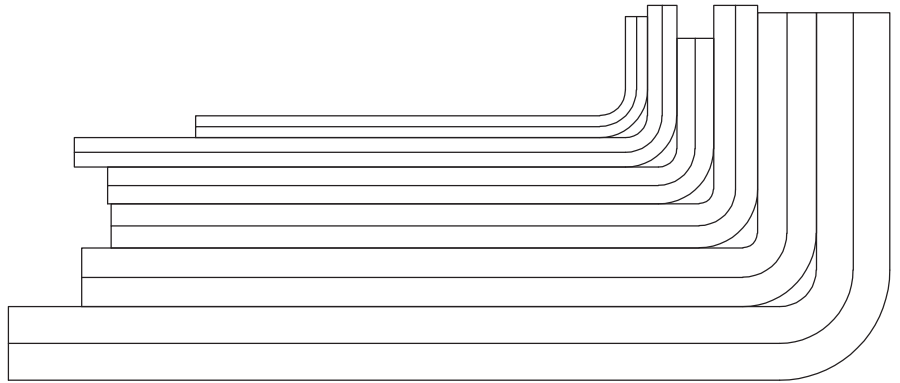

104 × 12

3# 4# 5# 6# 8# 10# × 1

mm

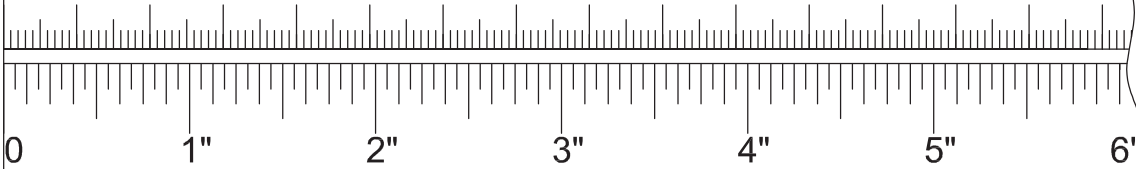
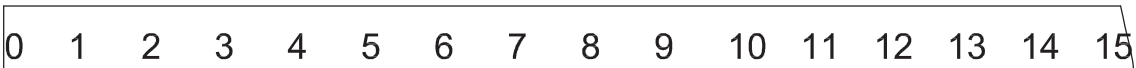

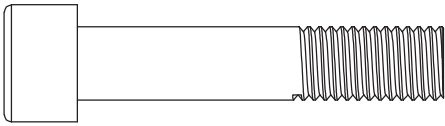

105 × 4

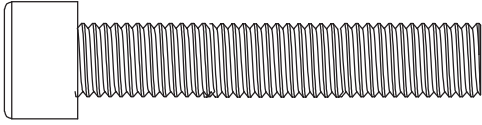
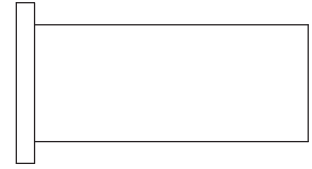
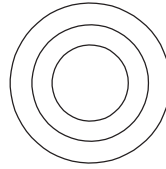

106 × 4

36 × 4

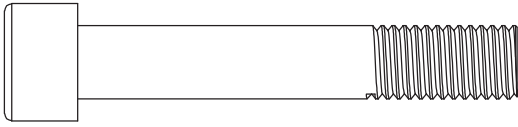

107 × 4

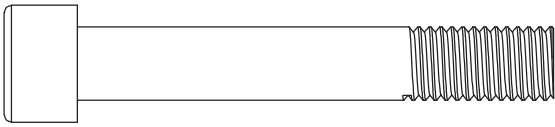
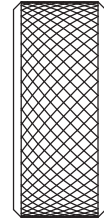
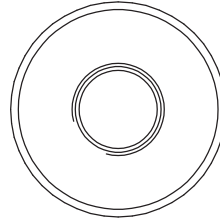

108 × 14

50 × 2

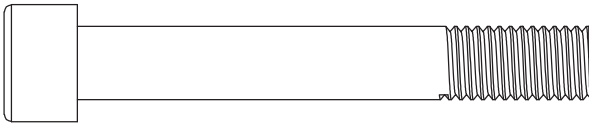

109 × 14

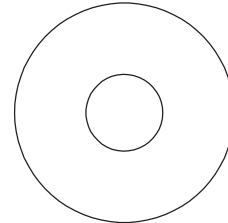

77 × 2

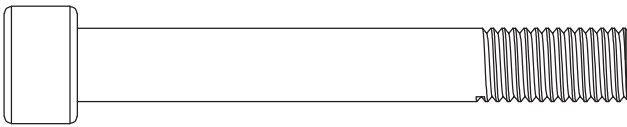

110 × 8

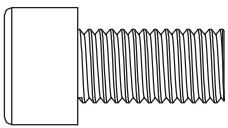
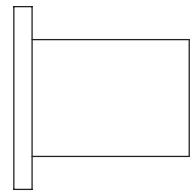
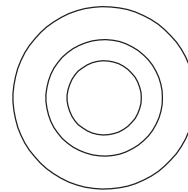

111 × 2

131 × 4

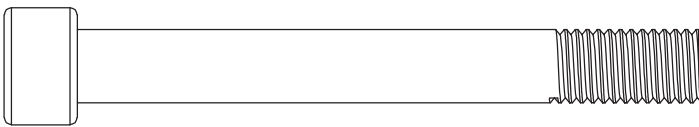

112 × 6



140 × 2

mm

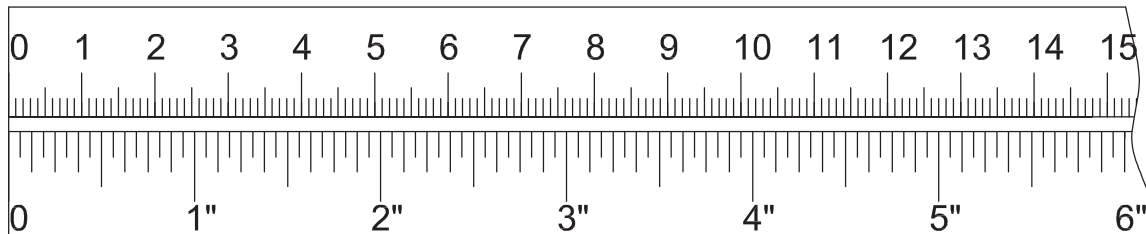

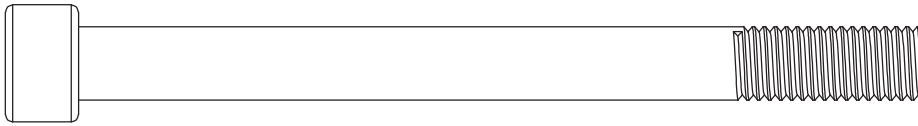

114 × 2

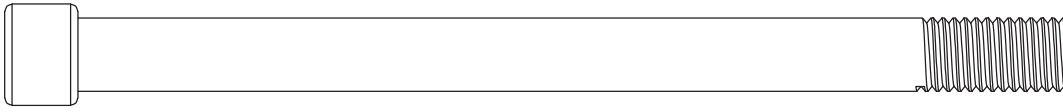

115 × 2

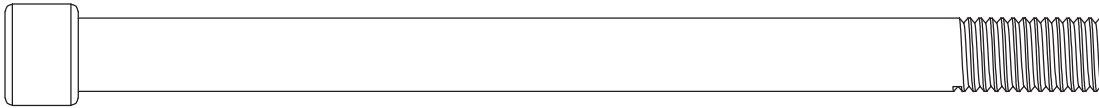

116 × 4

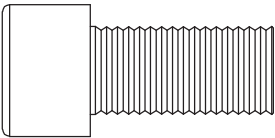

118 × 26

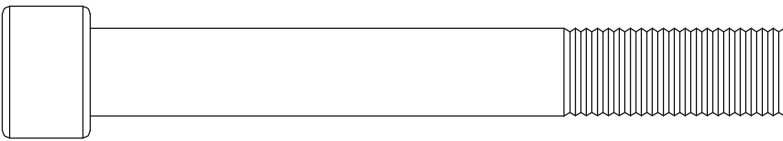

119 × 2

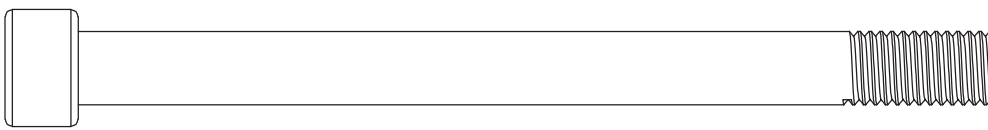

133 × 8

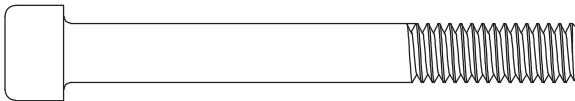

143 × 2

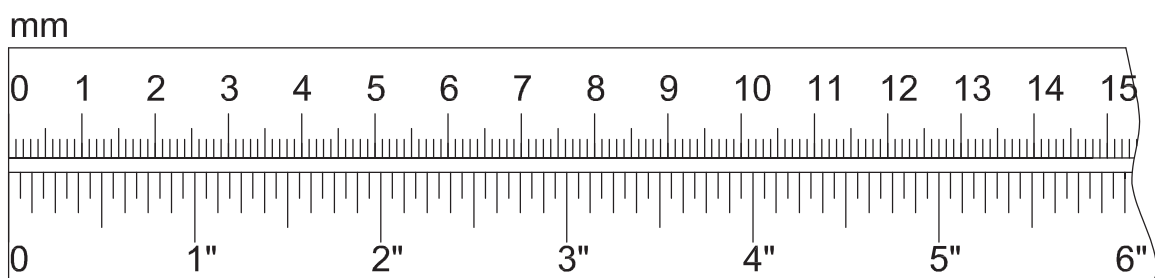



×8 M12×25



×8 Φ12

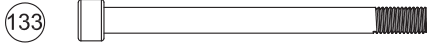

×4 M10×125



×4 M10



×8 Φ10

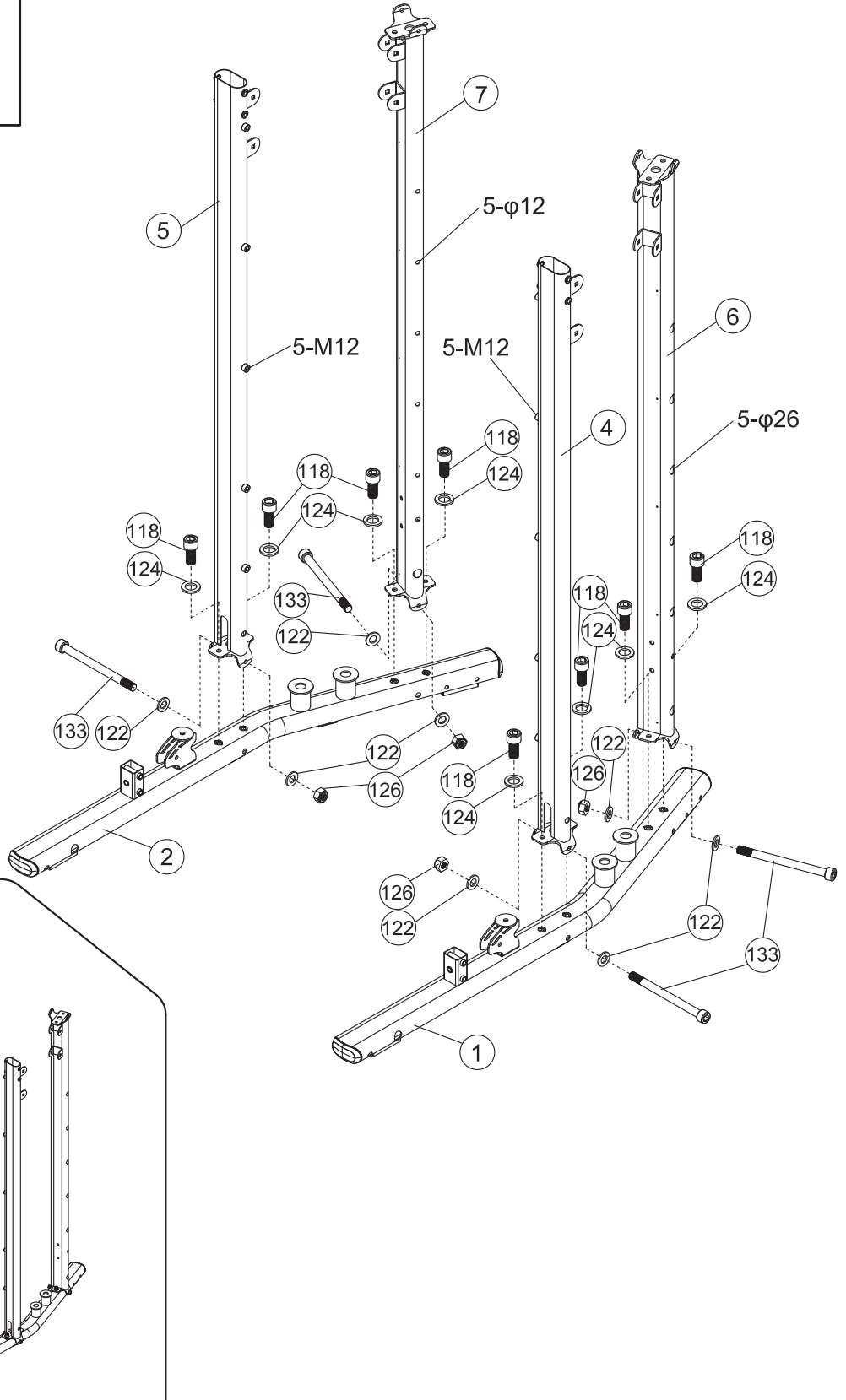
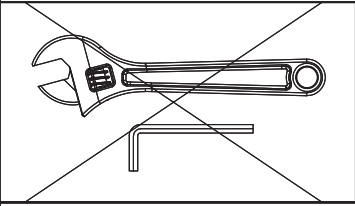



×12 M10×70



×10 Φ30×Φ10.5



×4 M10×125



×16 M10



×22 Φ10

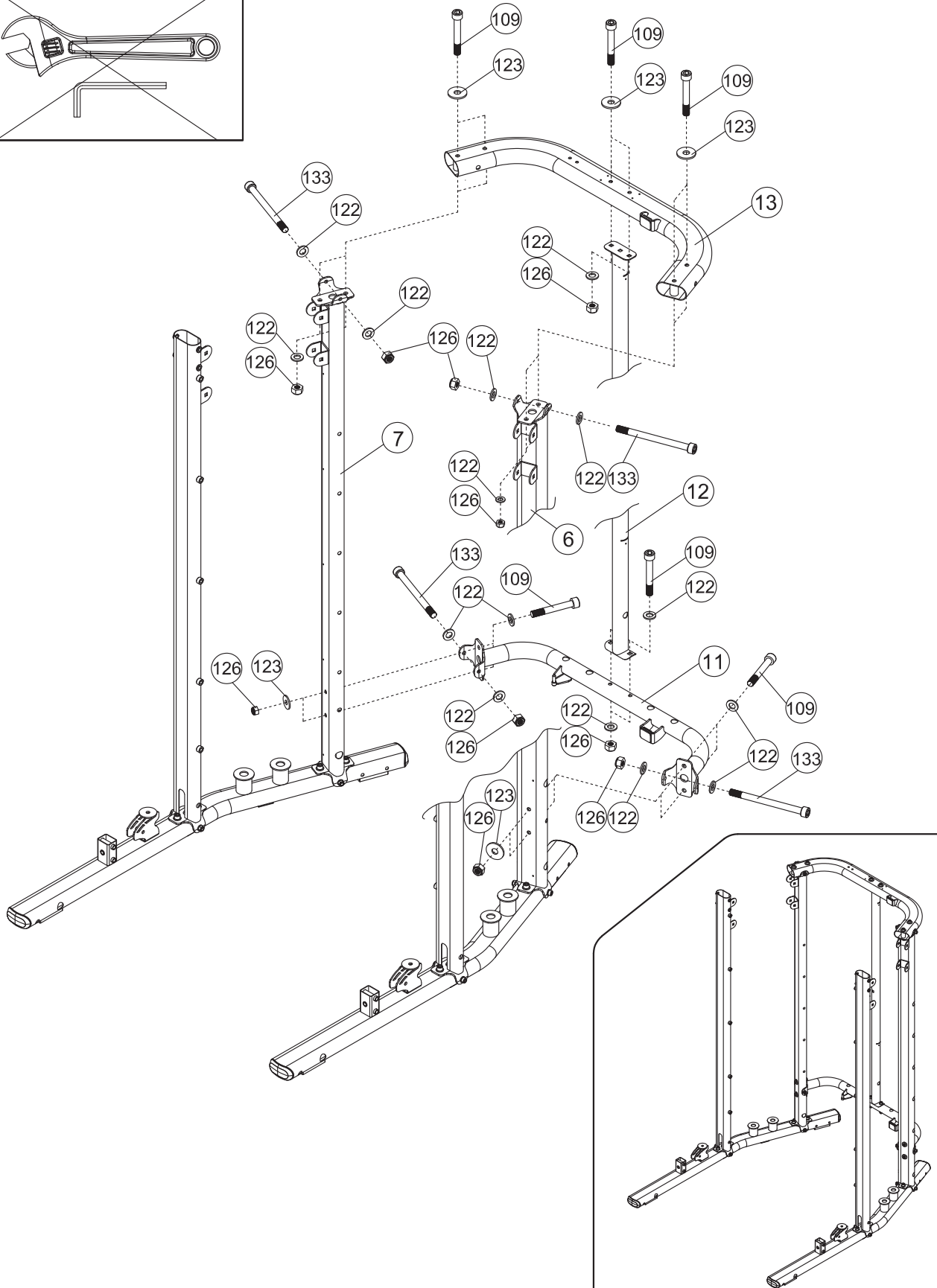
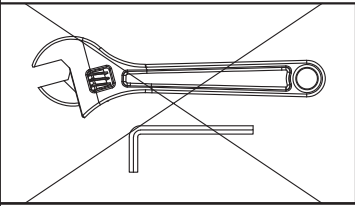



×8 M10×75

126



×8 M10



×16 Φ10

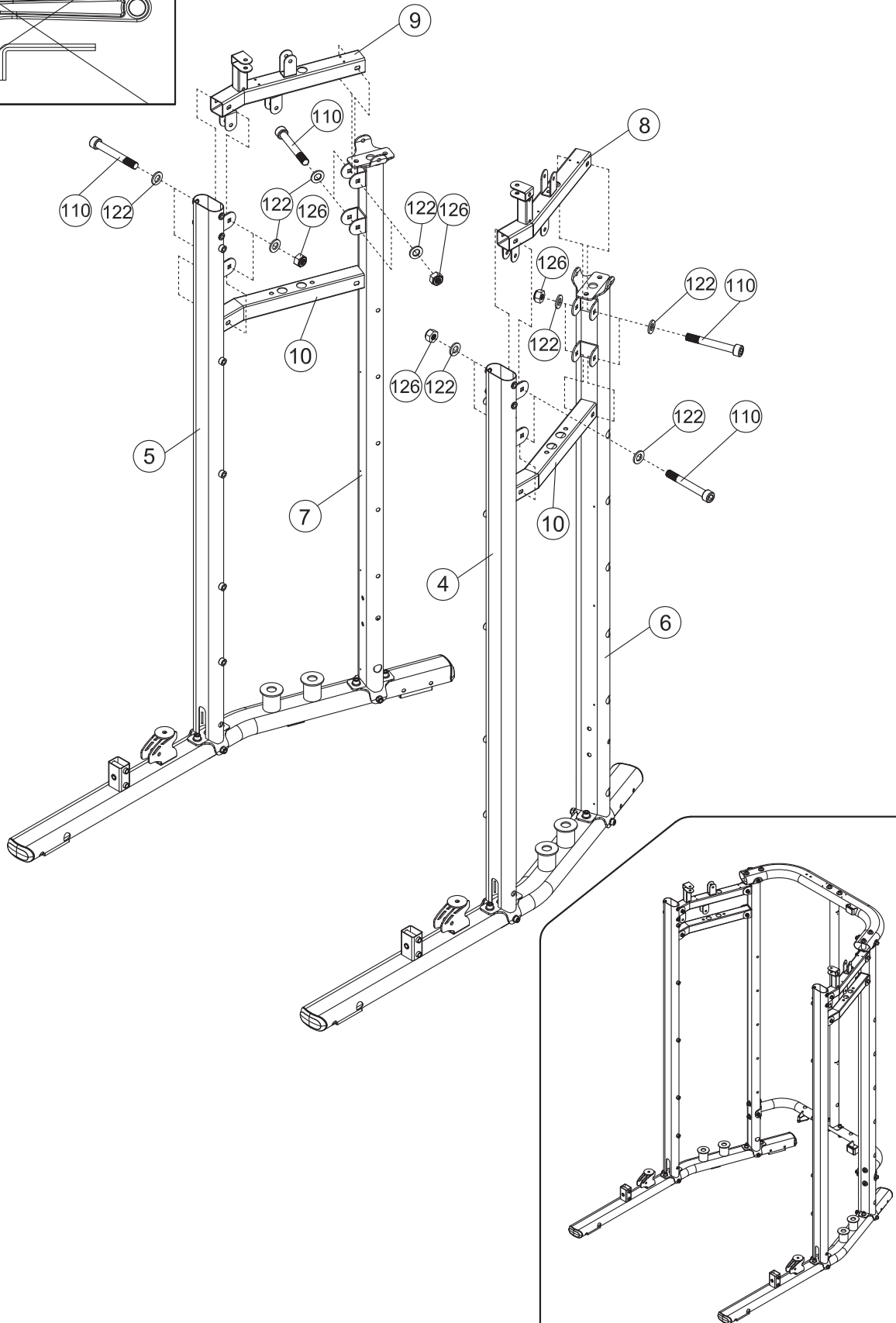
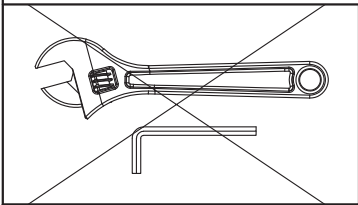

3



108		x2	M10x65	124		x4	Φ12
112		x4	M10x85	126		x6	M10
119		x2	M12x95	127		x2	M12
122		x12	Φ10				

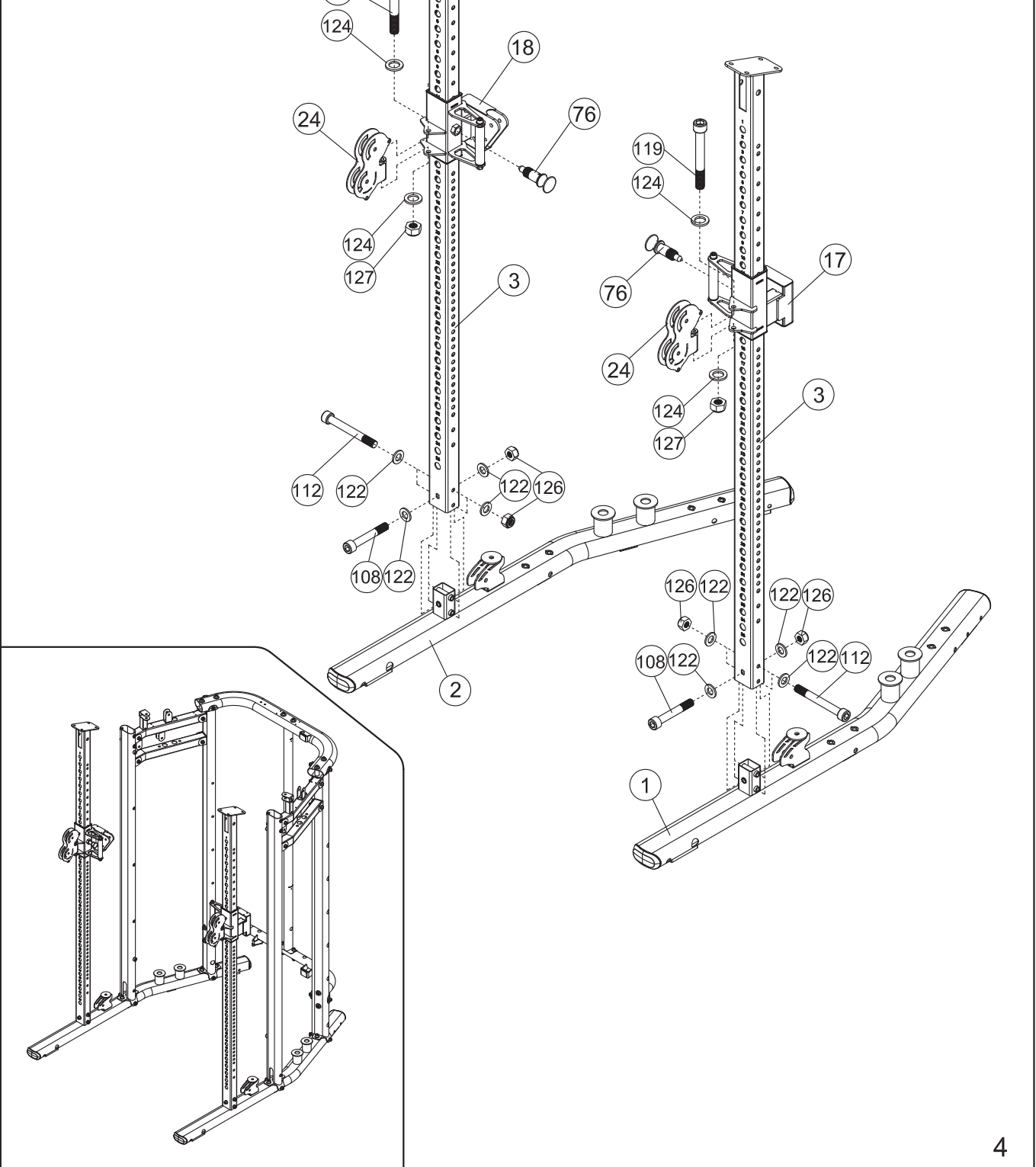
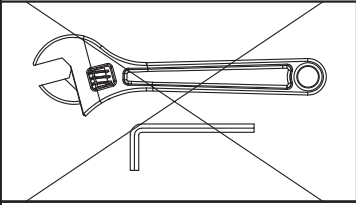

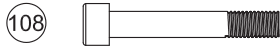

×8 M10×65



×8 M12×25



×16 Φ10







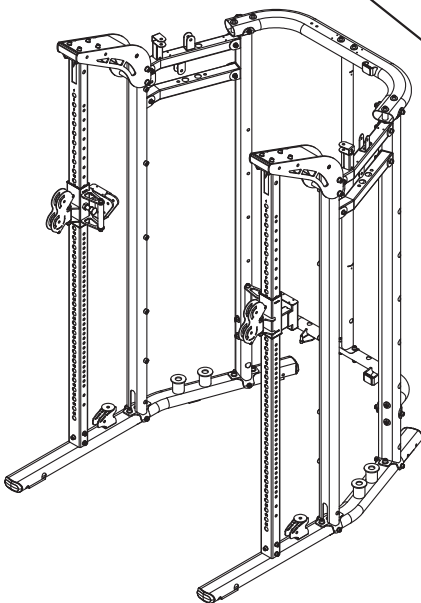
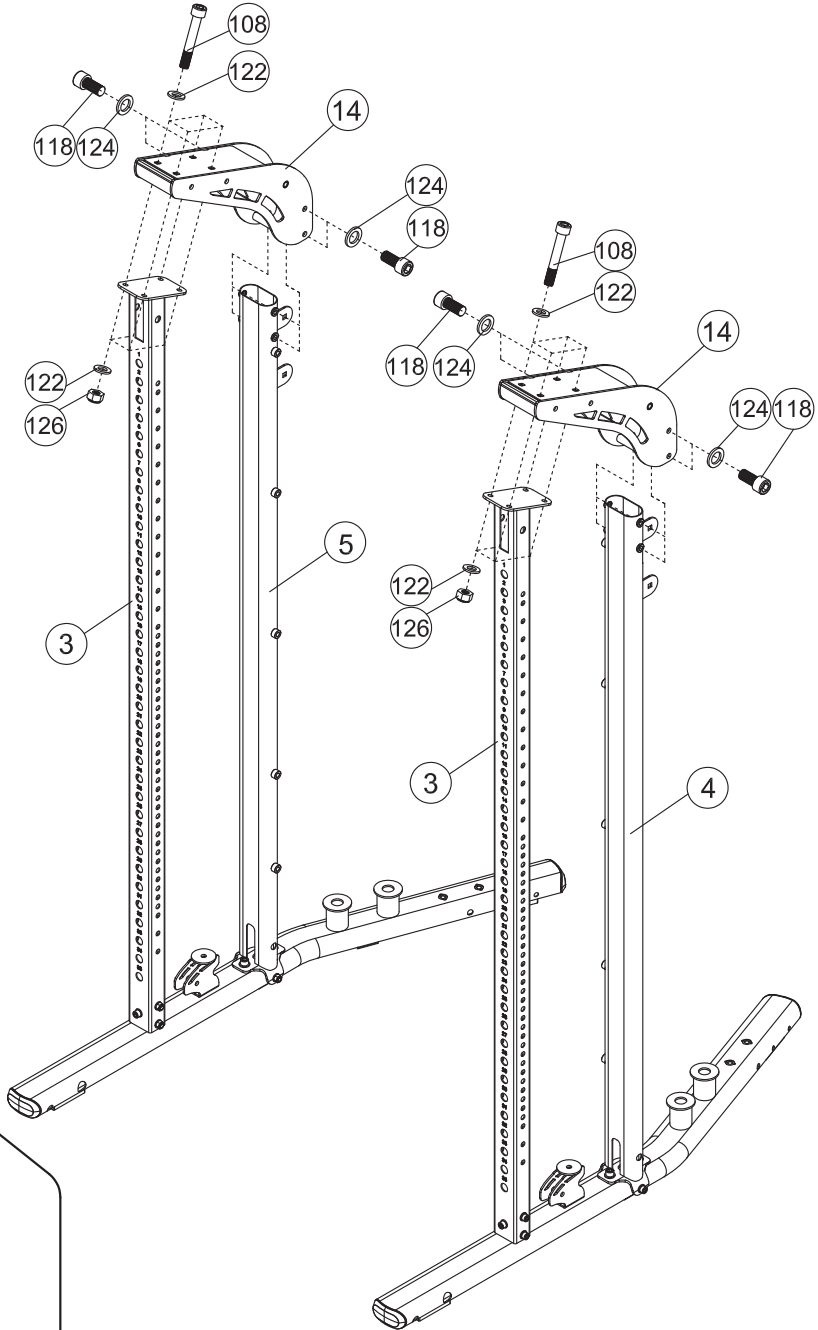
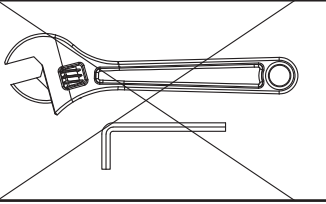

×8 Φ12

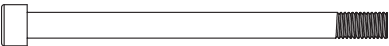

×8 M10



- |    |   |    |           |    |   |   |    |     |
|----|---|----|-----------|----|---|---|----|-----|
| ⑩③ |  | x4 | M10×25    | ⑫② |  |   | x8 | Φ10 |
| ⑪⑥ |  | x4 | M10×140   | ⑫⑥ |  |  | x4 | M10 |
| ⑫③ |  | x4 | Φ30×Φ10.5 |    |   |   |    |     |

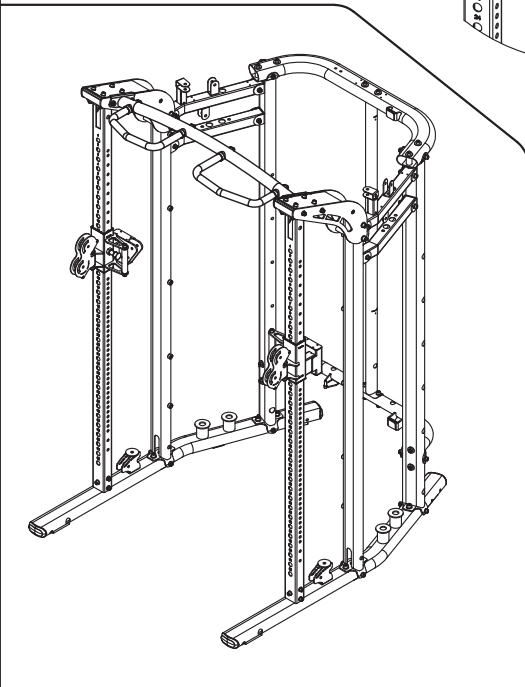
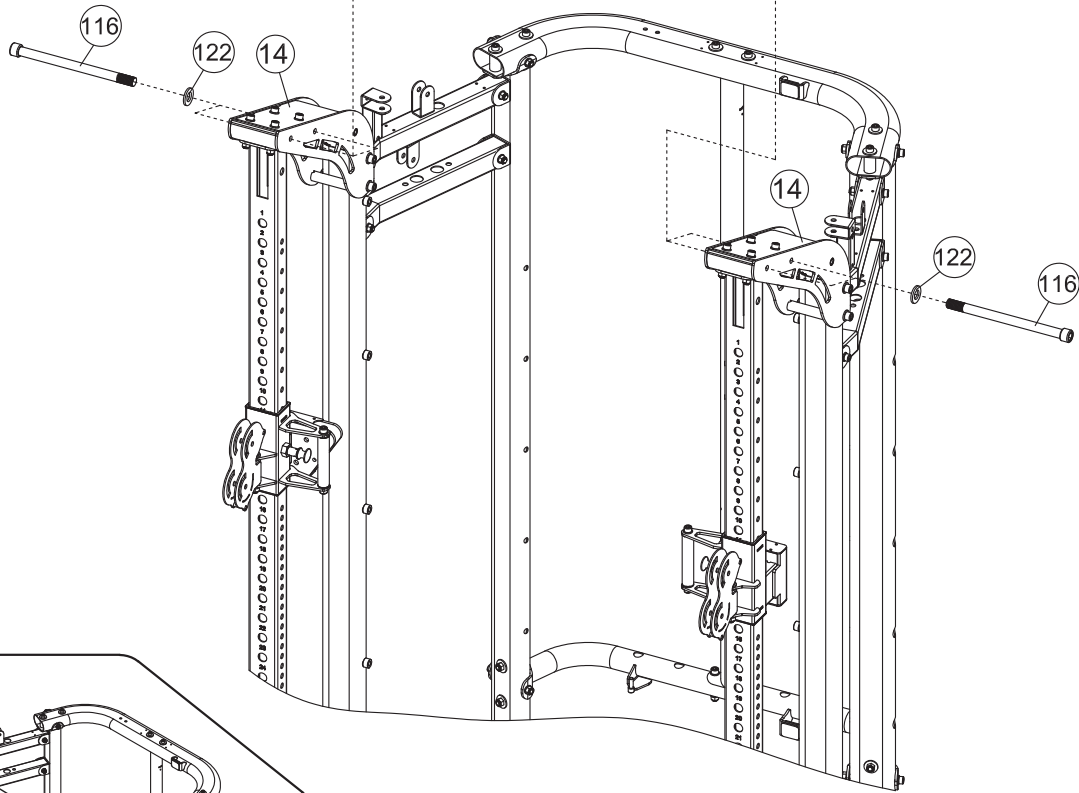
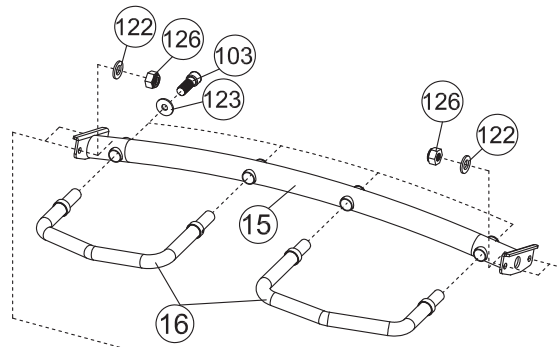
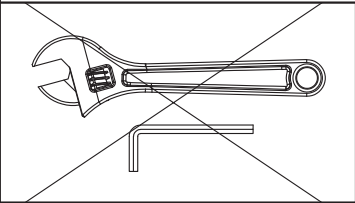

118

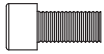

×10 M12×25

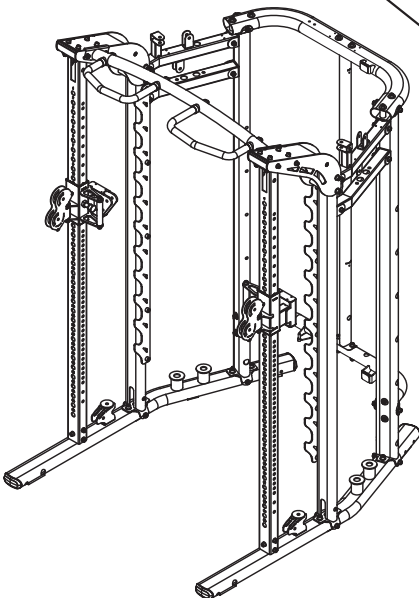
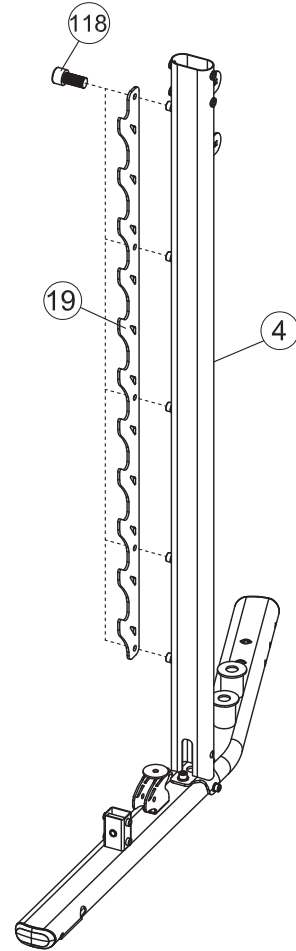
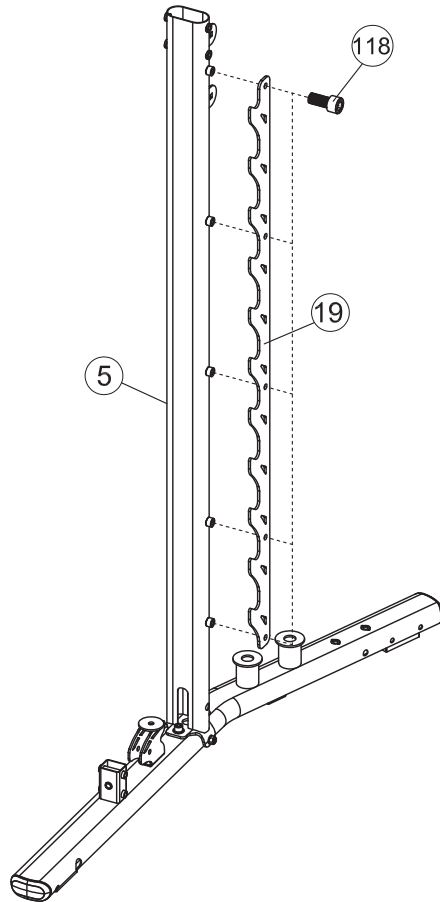
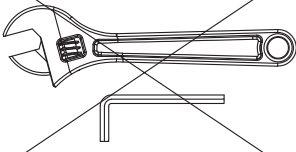

102



x4

M10x20







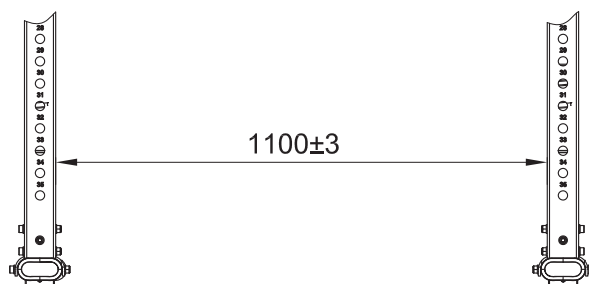
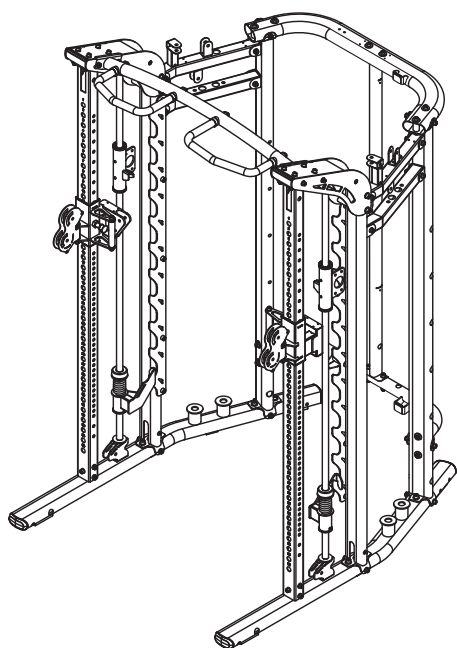
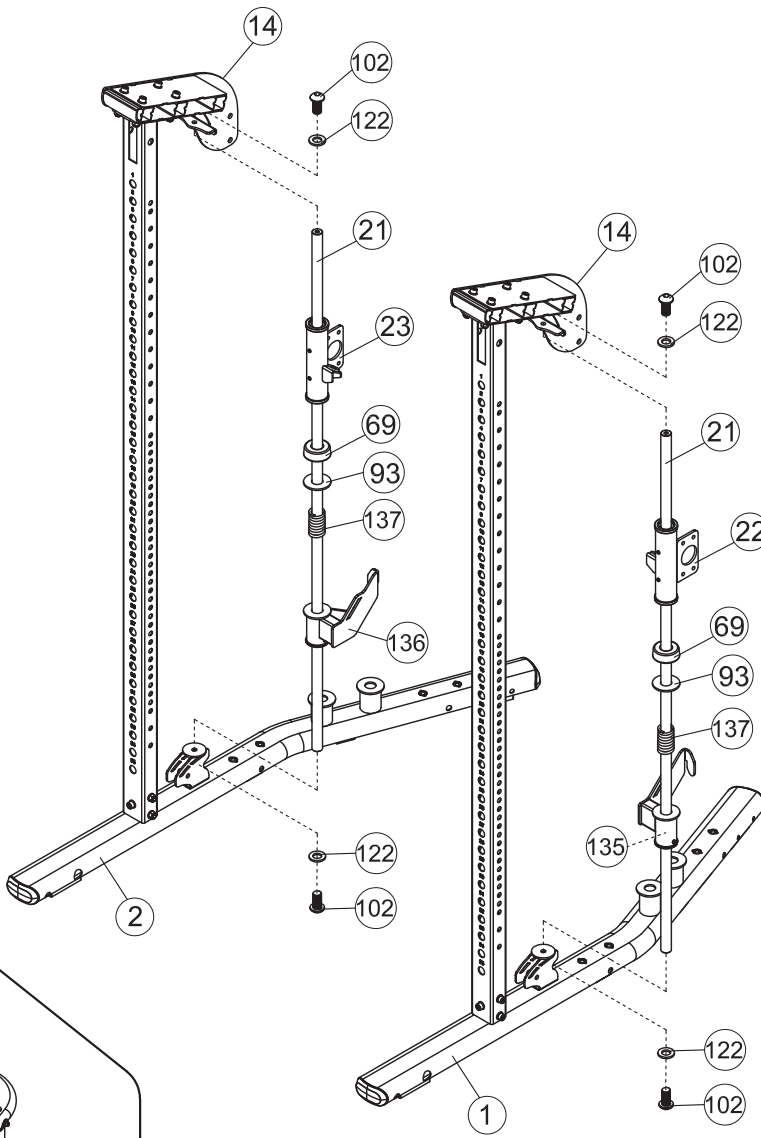
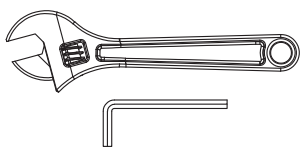

122



x4

Φ10



99		x2	M8x20	100		x8	M8x30
101		x2	M8x30	121		x16	Φ8
125		x8	M8	128		x2	Φ8
129		x2	R20xφ9	77		x2	Φ30xΦ9

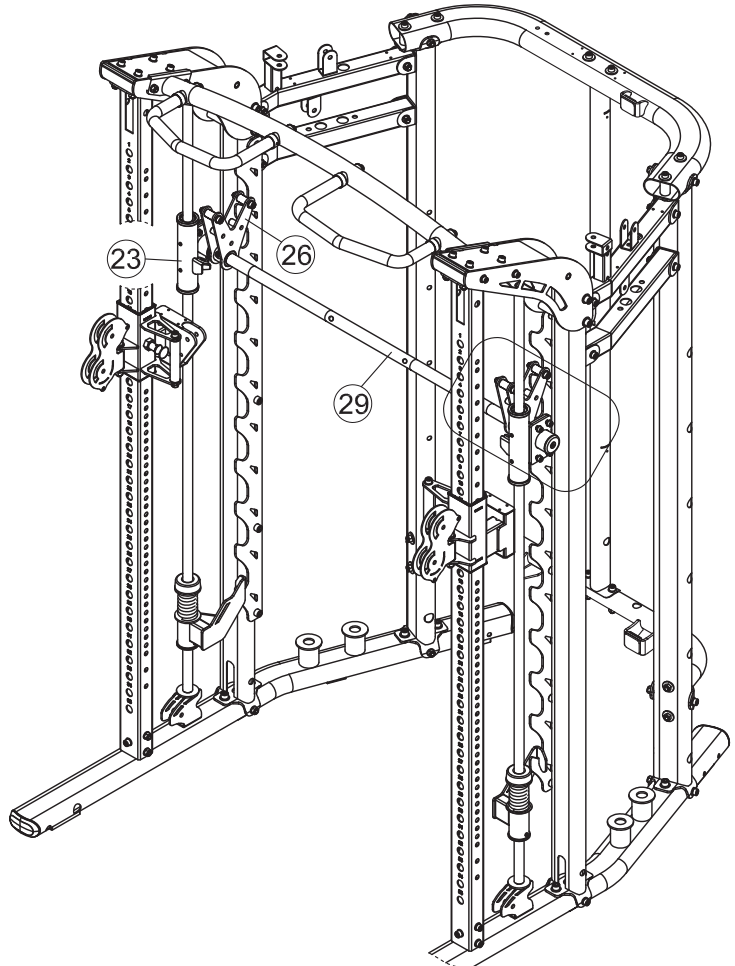
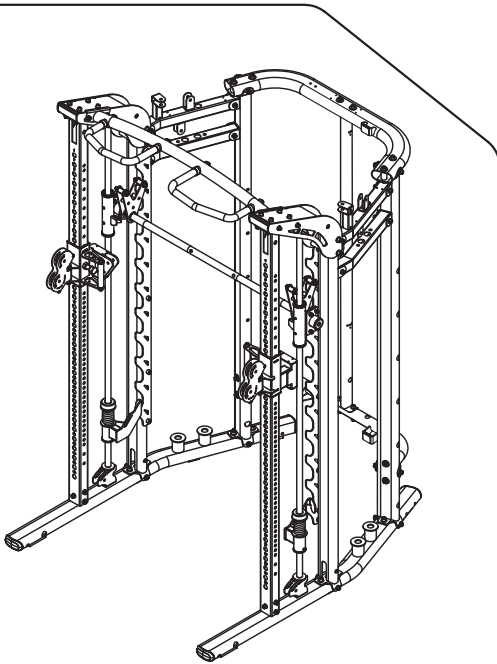
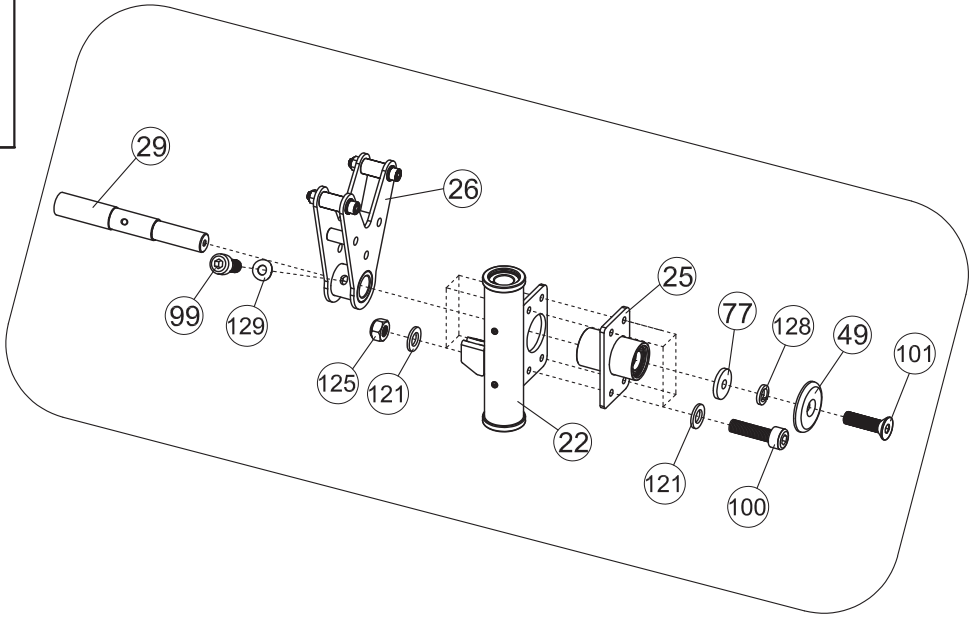
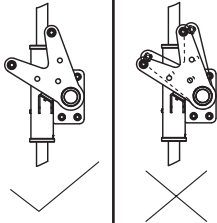
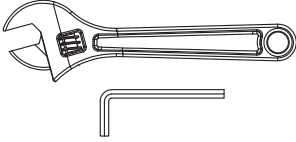

92



x20 ST4.8x13

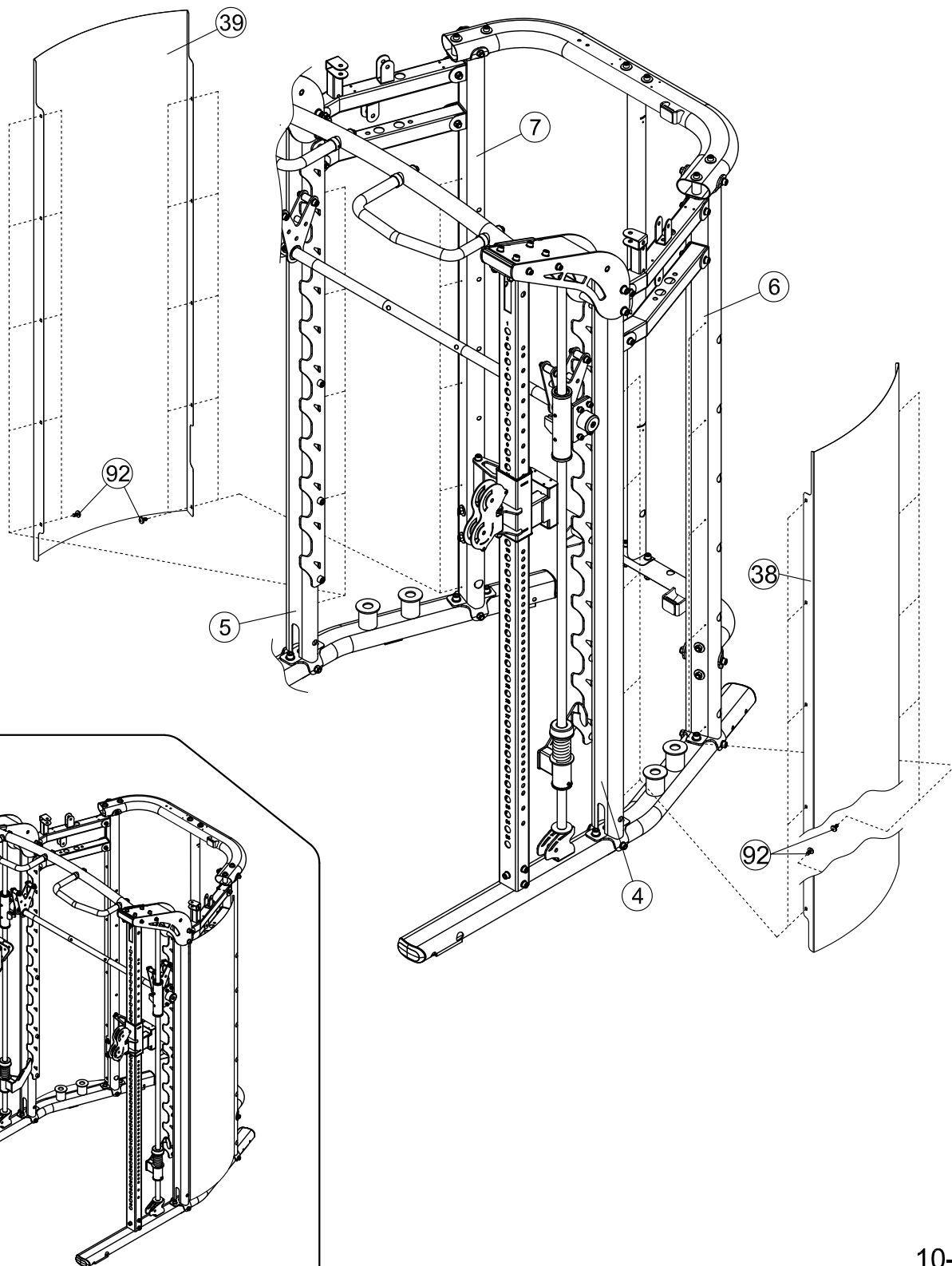
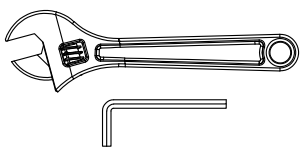

106



x2

M10x55

108

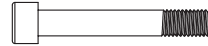

x4

M10x65

122



x4

Φ10

50



x2

Φ28x12xM12

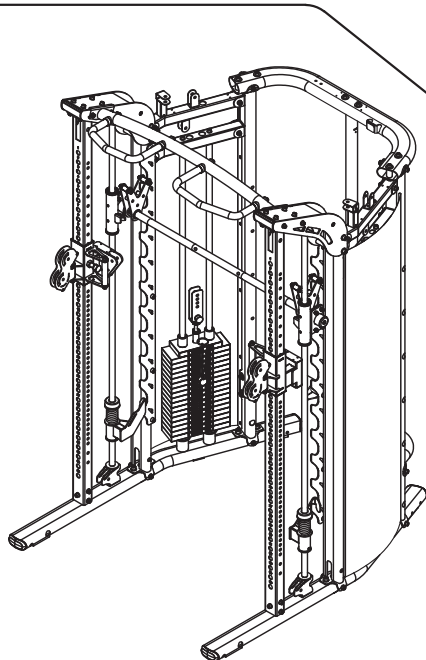
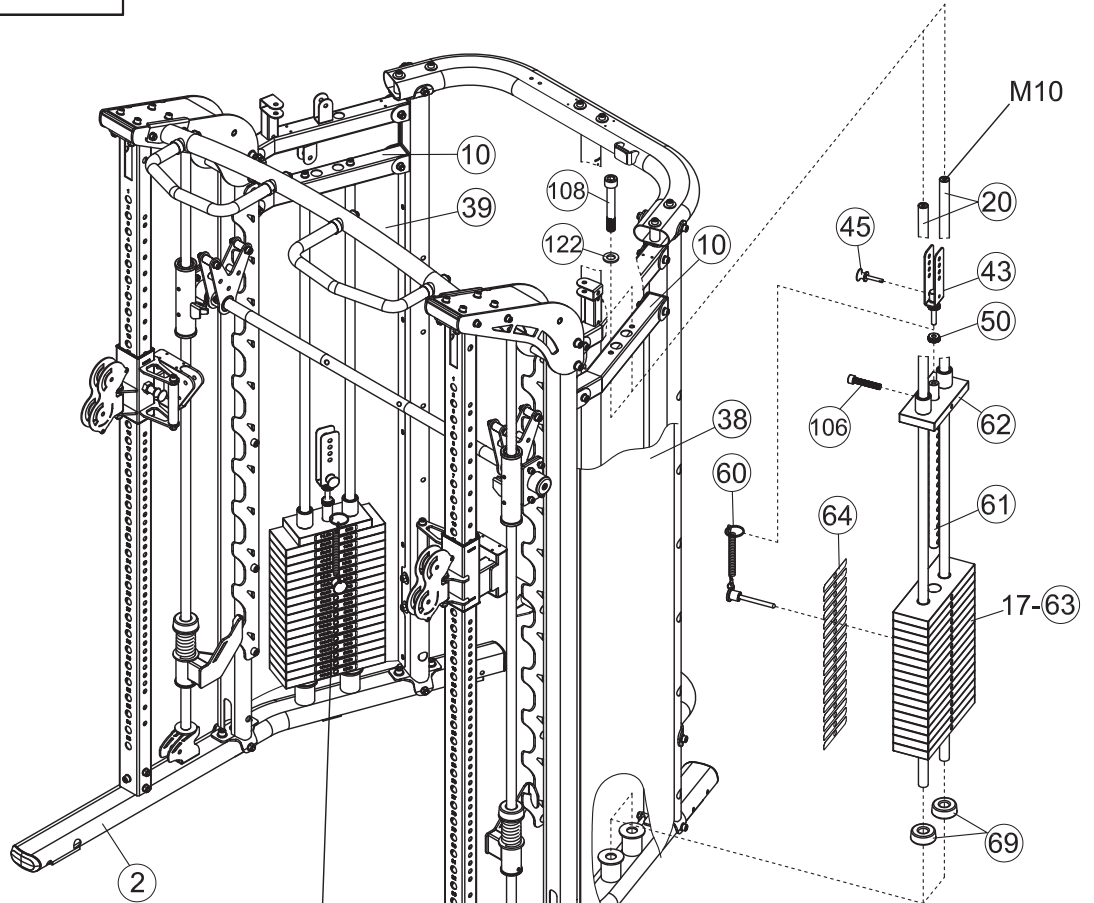
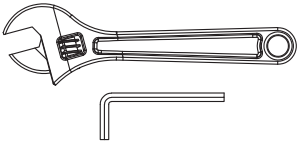





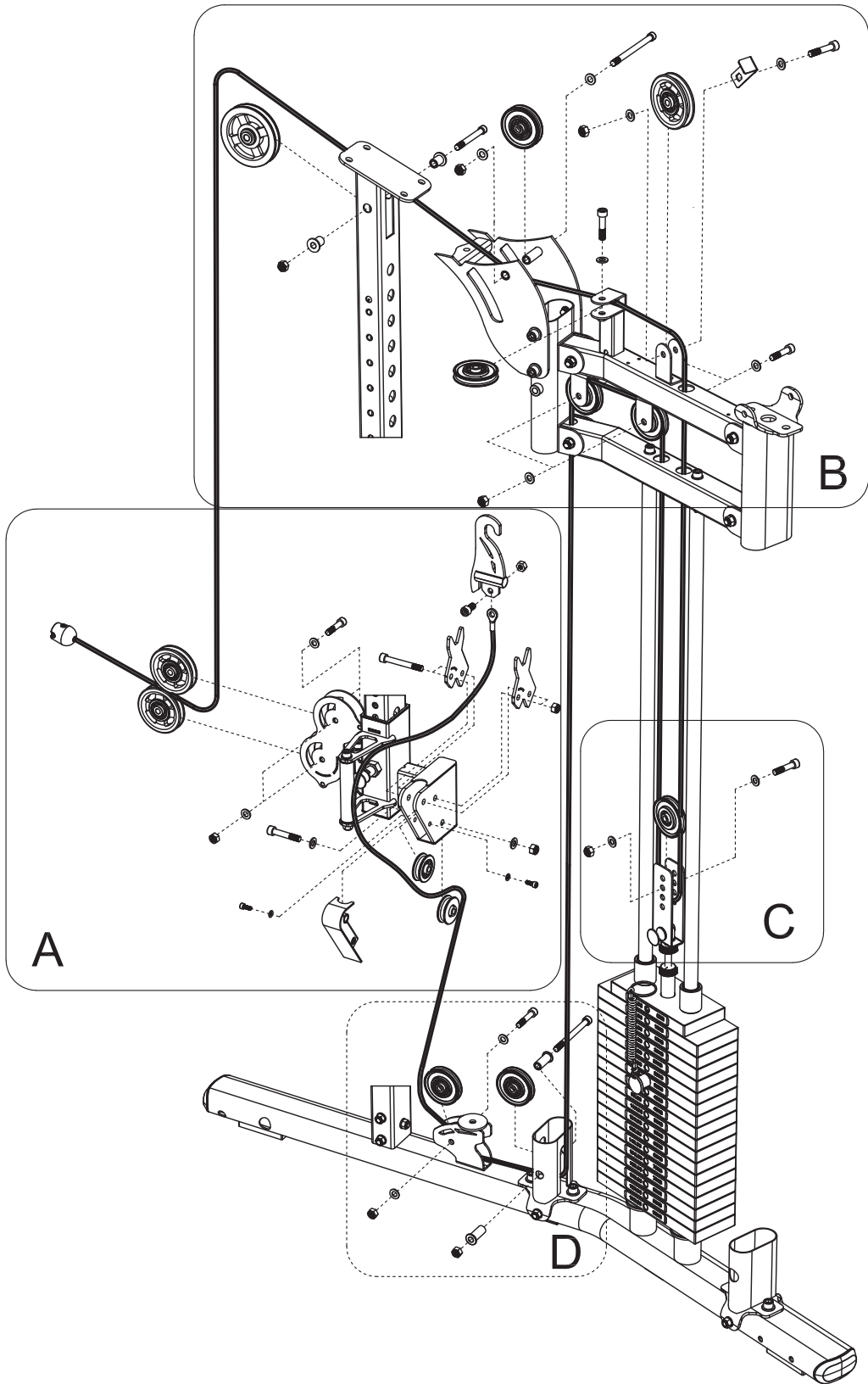

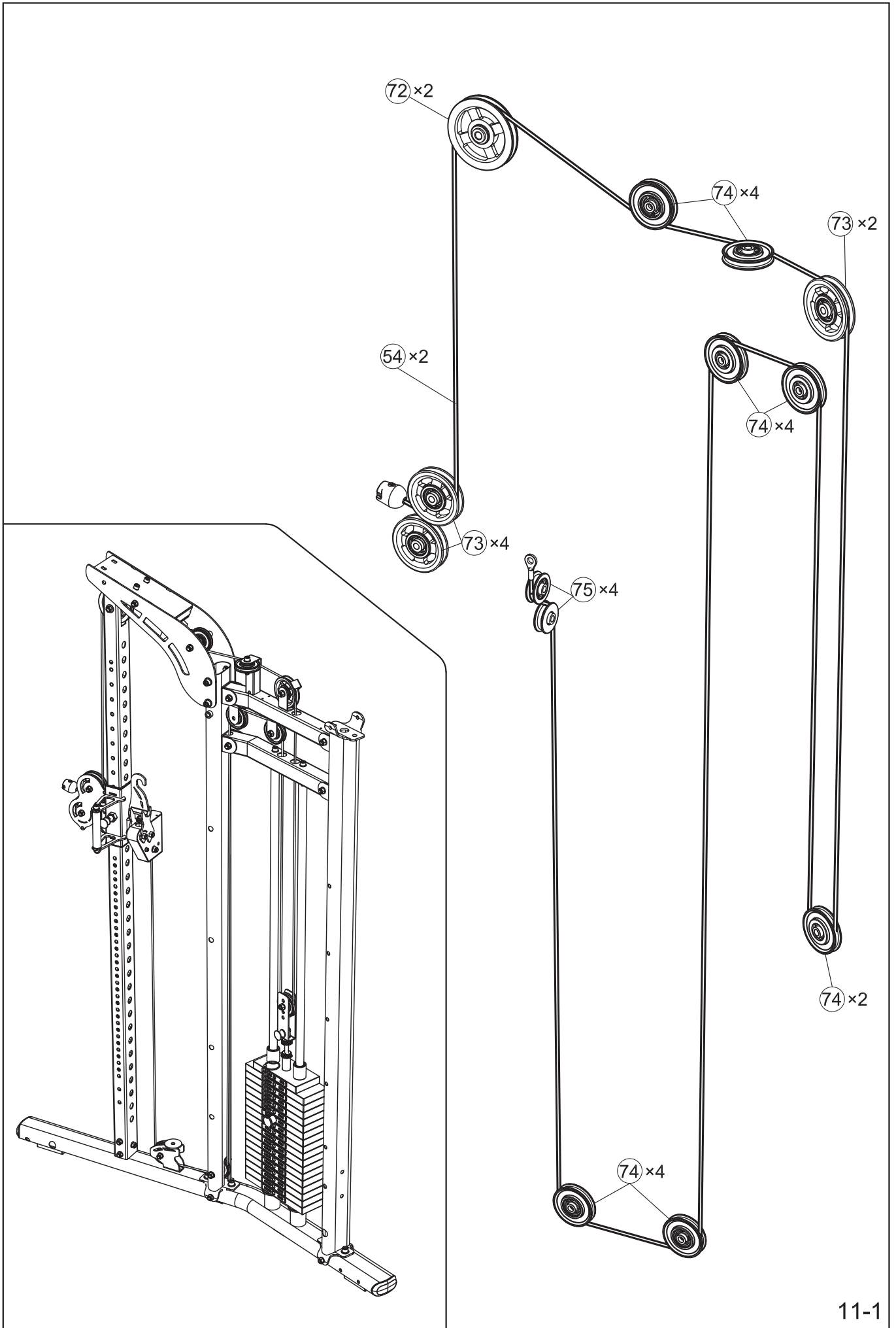

- 11LBS ○ 5KG
- 22LBS ○ 10KG
- 33LBS ○ 15KG
- 44LBS ○ 20KG
- 55LBS ○ 25KG
- 66LBS ○ 30KG
- 77LBS ○ 35KG
- 88LBS ○ 40KG
- 99LBS ○ 45KG
- 110LBS ○ 50KG
- 121LBS ○ 55KG
- 132LBS ○ 60KG
- 143LBS ○ 65KG
- 154LBS ○ 70KG
- 165LBS ○ 75KG
- 176LBS ○ 80KG
- 187LBS ○ 85KG
- 198LBS ○ 90KG





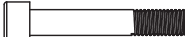



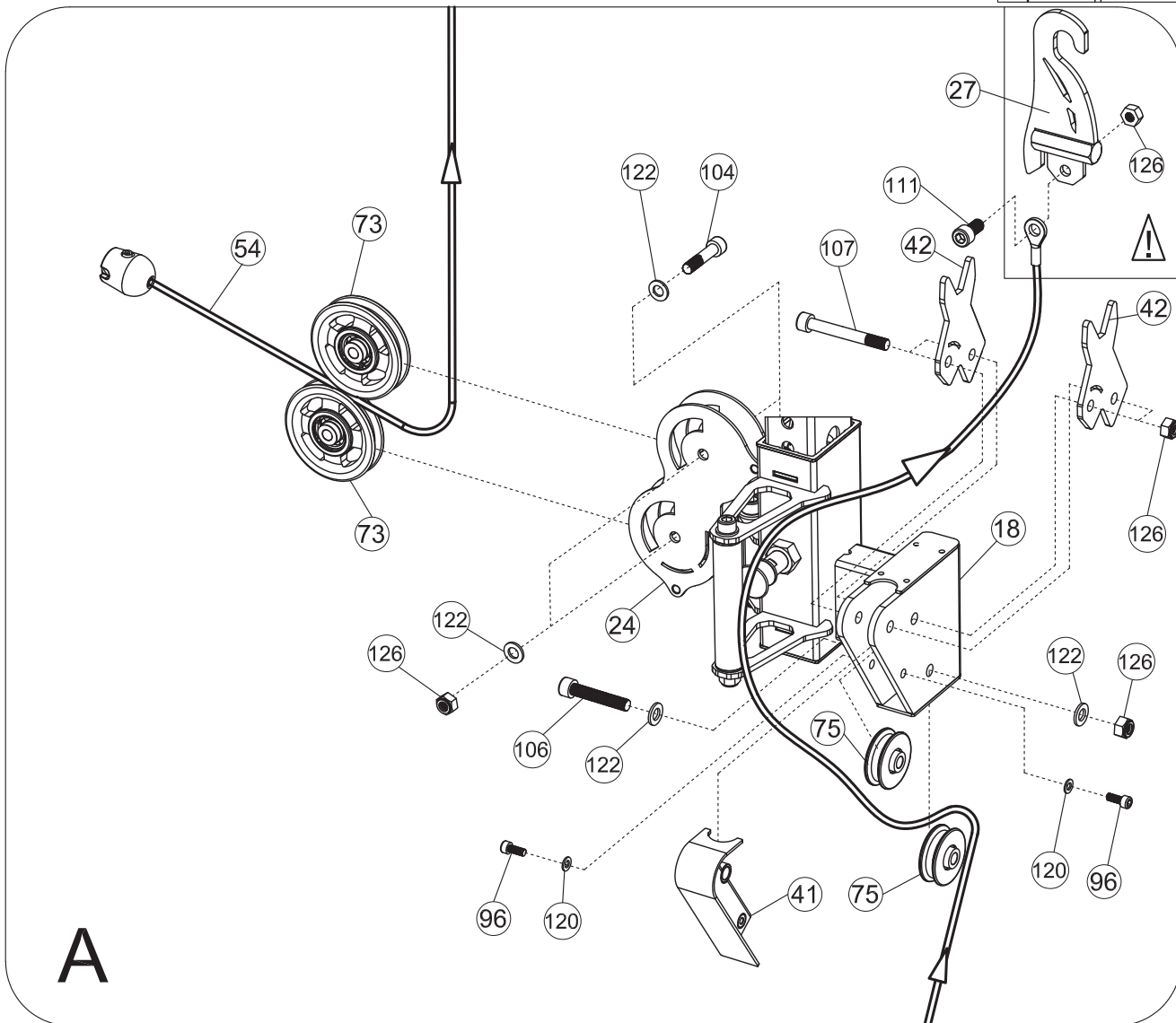
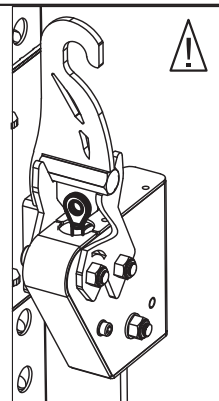
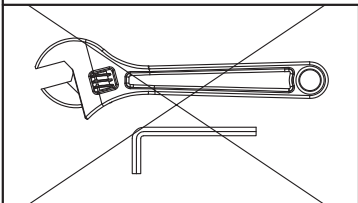



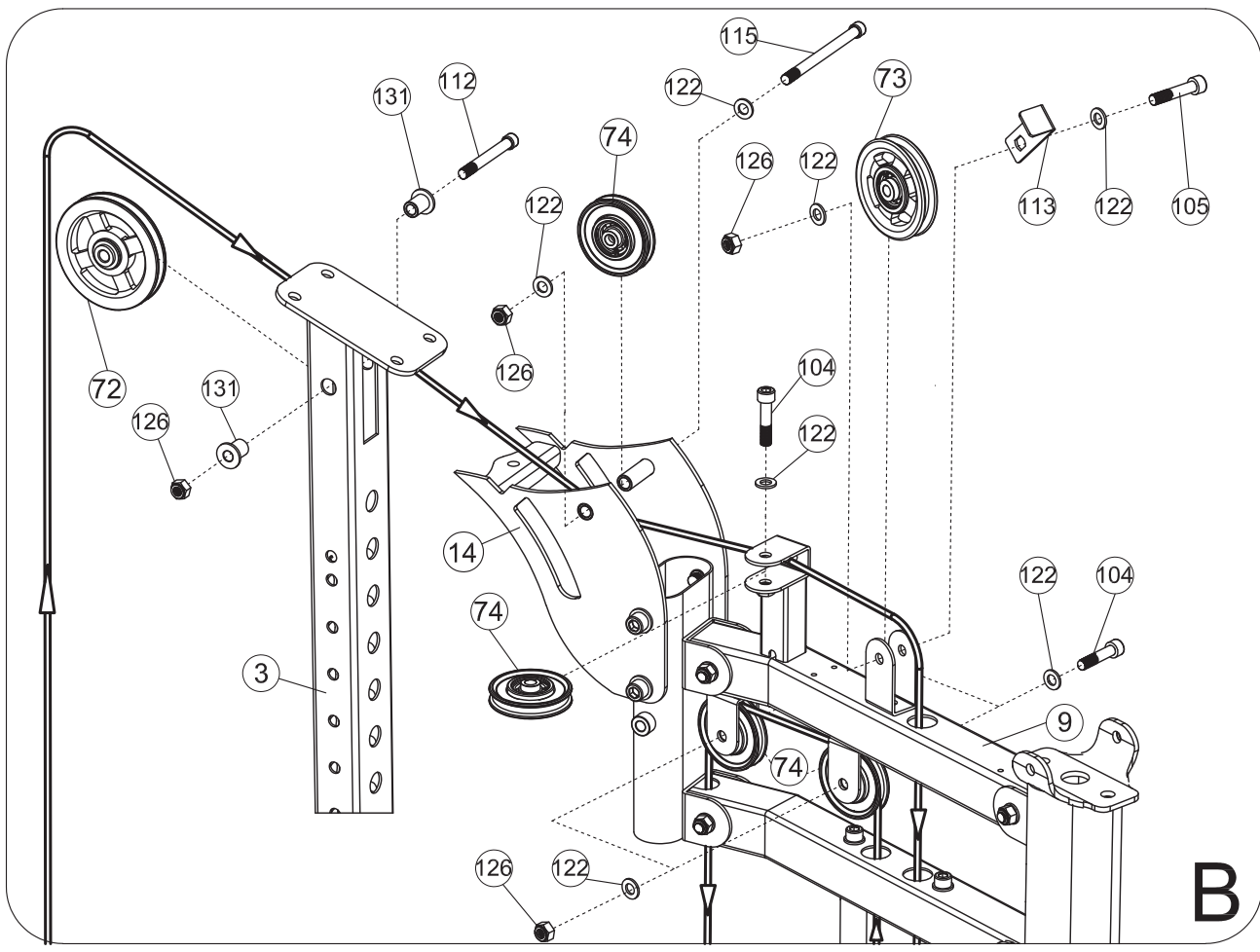
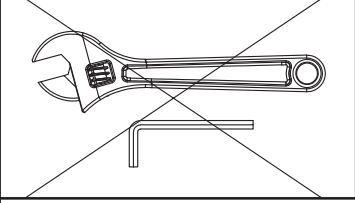

96		x4	M6x15	111		x2	M10x20
104		x4	M10x45	120		x4	Φ6
106		x2	M10x55	122		x12	Φ10
107		x4	M10x60	126		x12	M10

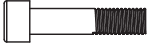

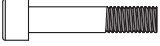
11-A







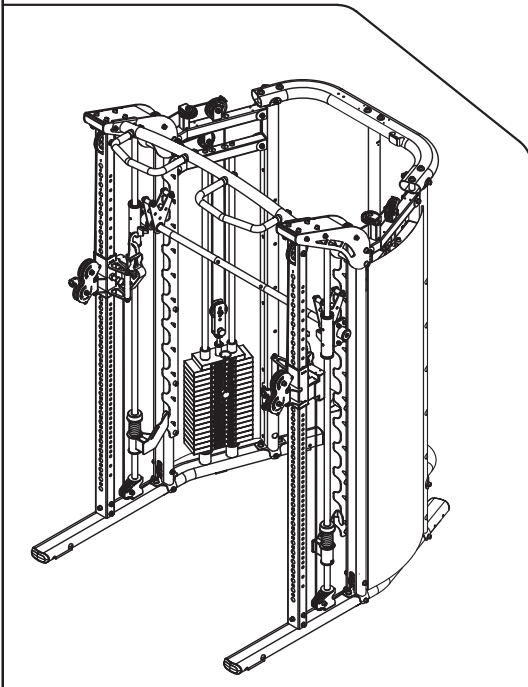
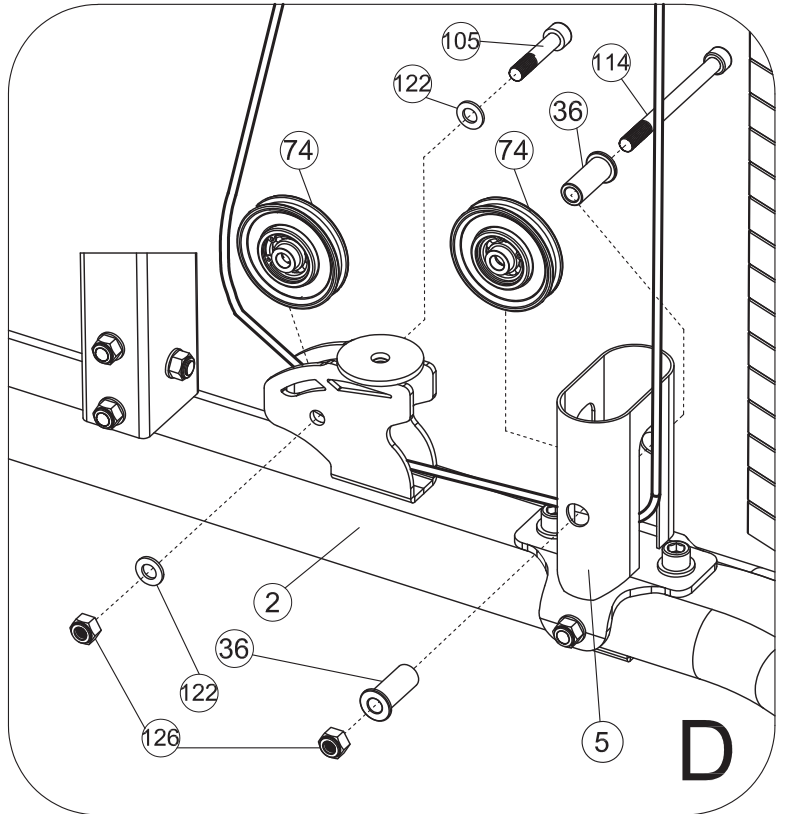
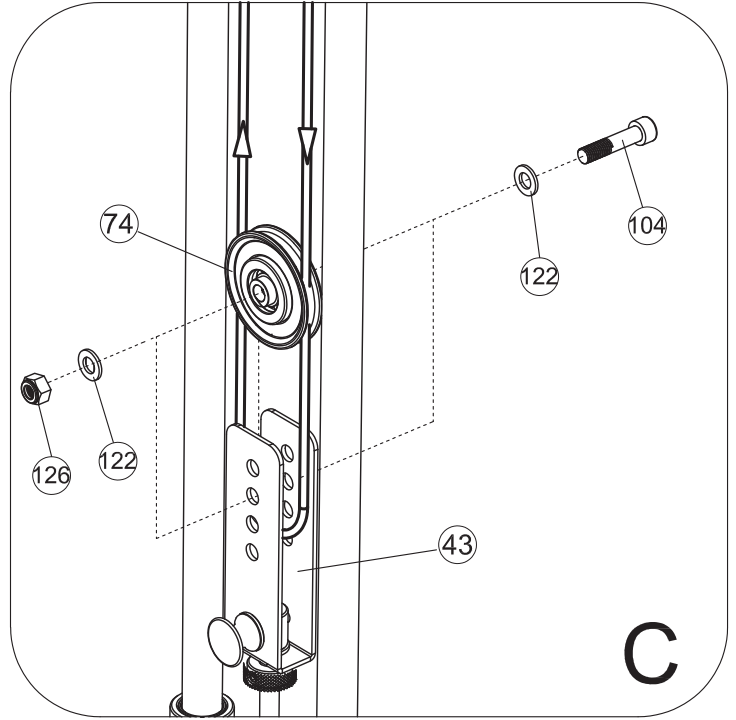
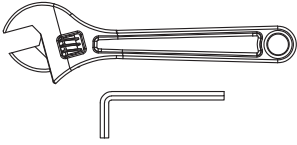



104		x6	M10x45	122		x18	Φ10
105		x2	M10x50	126		x10	M10
112		x2	M10x85	131		x4	Φ25xΦ10.2
115		x2	M10x135				



- |    |   |    |         |    |   |   |    |               |
|----|---|----|---------|----|---|---|----|---------------|
| ⑩④ |  | ×2 | M10×45  | ⑩② |  |   | ×8 | Φ10           |
| ⑩⑤ |  | ×2 | M10×50  | ⑩⑥ |  |  | ×6 | M10           |
| ⑩④ |  | ×2 | M10×115 |    |   |   |    |               |
| ③⑥ |  |    |         | ×4 |   |    |    | Φ22×Φ16×Φ10.5 |

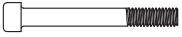

11-C  
11-D

96		x4	M6x15	120			x4	Φ6
109		x2	M10x70	121			x4	Φ8
134		x2	M6	122			x4	φ10
140		x2	φ12.7x25xM6	125			x2	M8
143		x2	M8x70	126			x2	M10

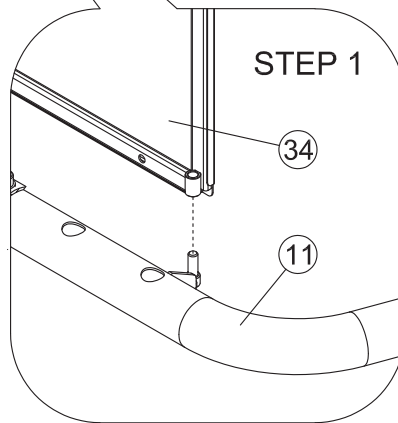
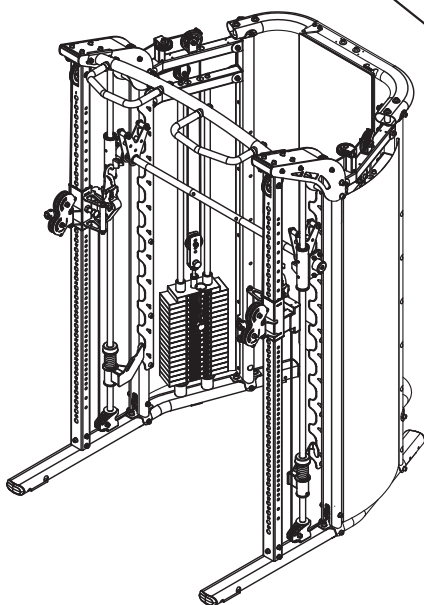
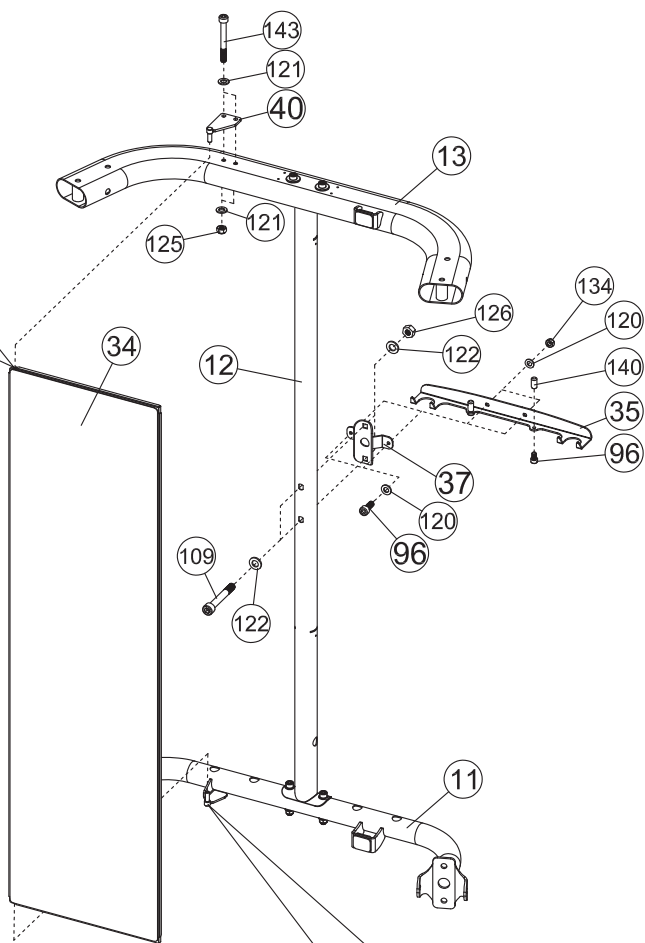
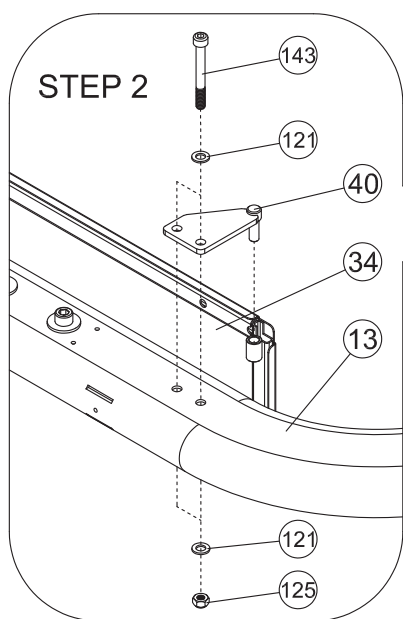
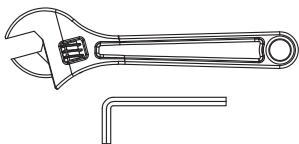

12

96



x24 M6x15

120



x24

Φ6

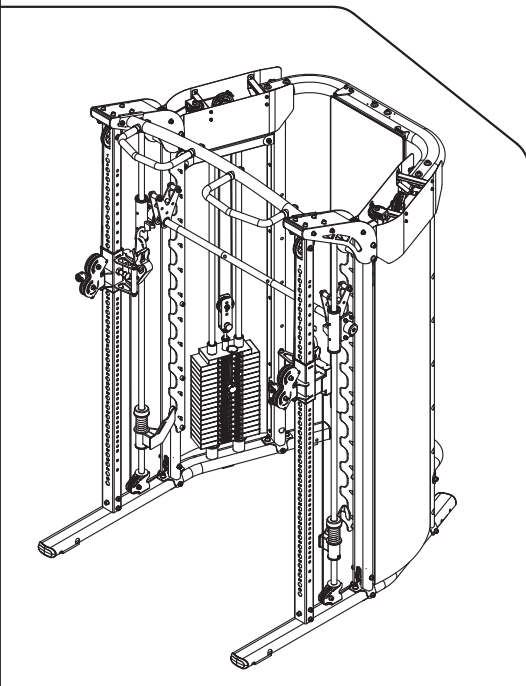
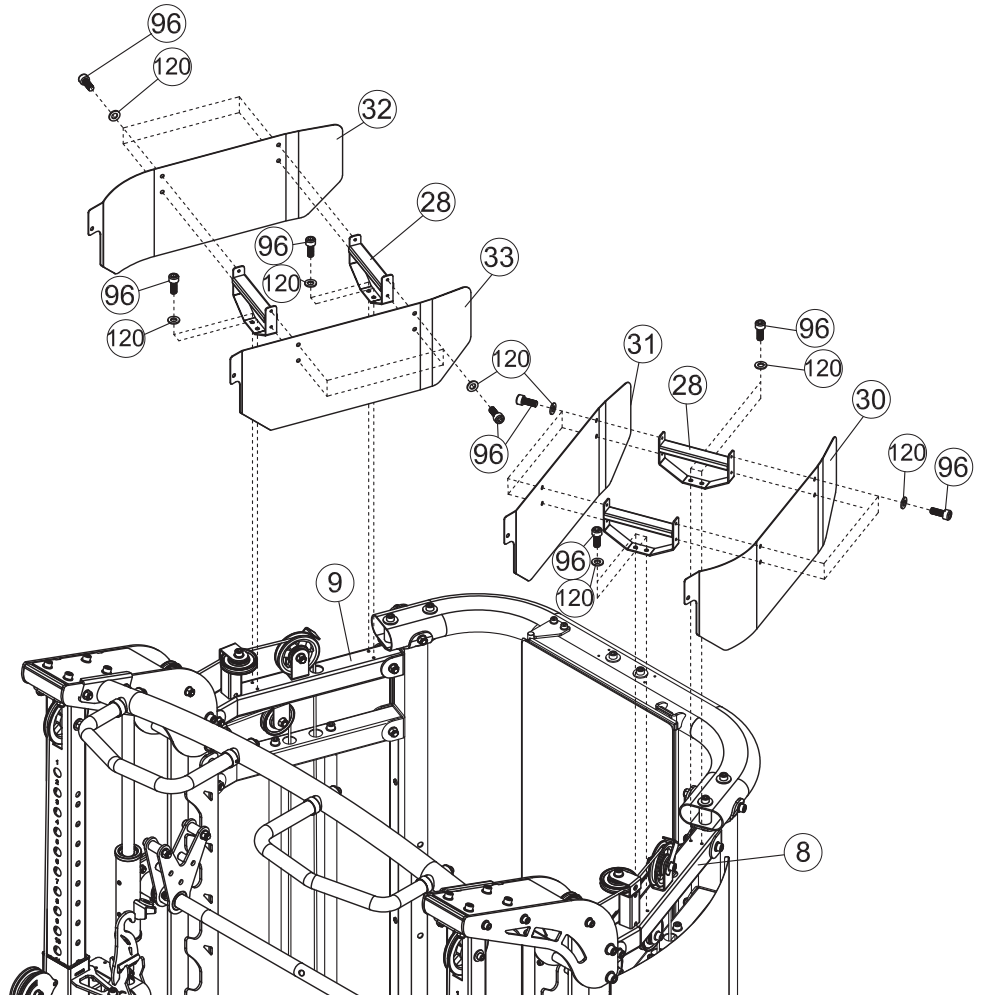
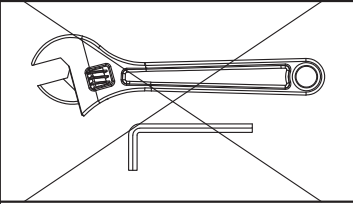

92



×5 ST4.8×13

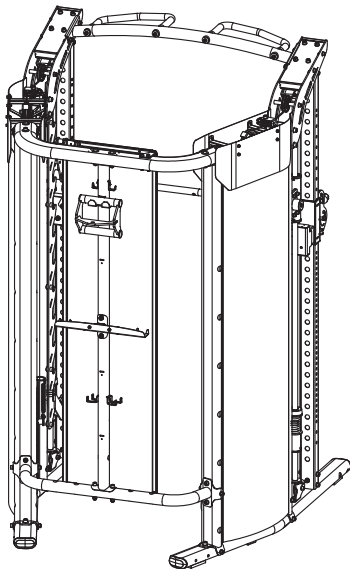
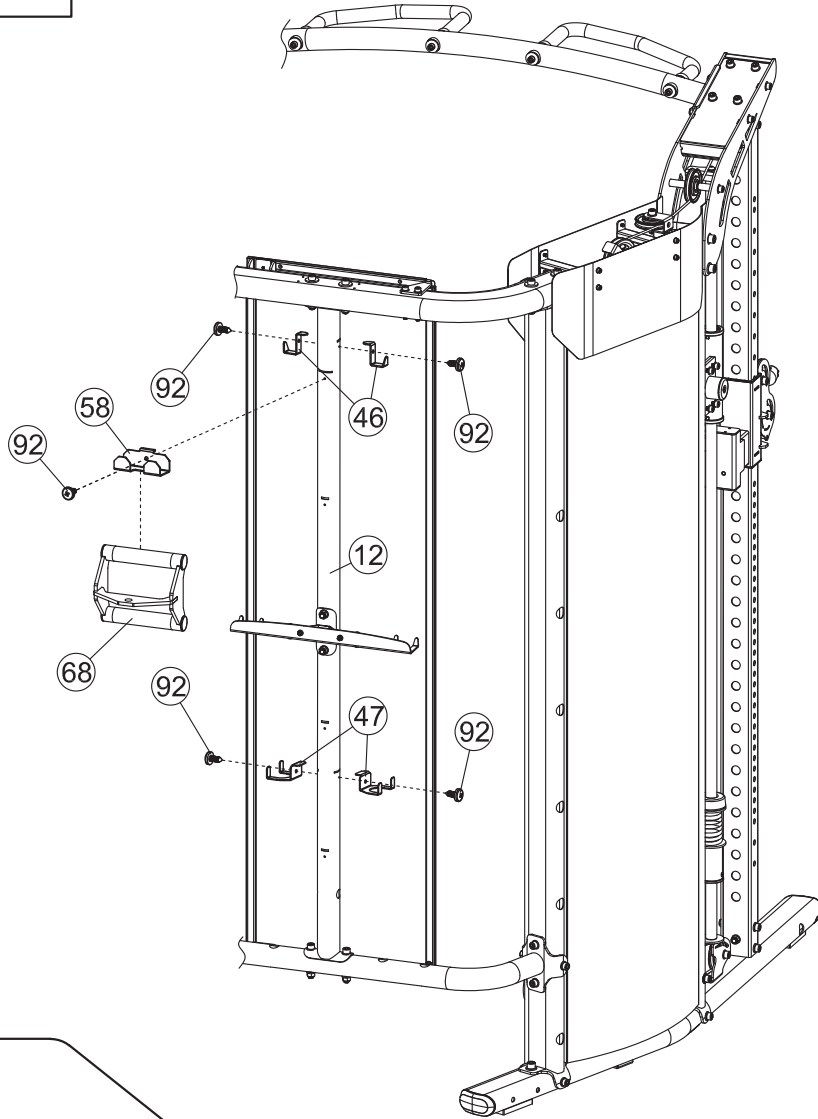
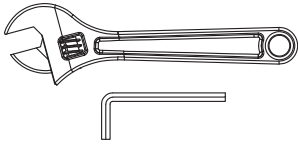



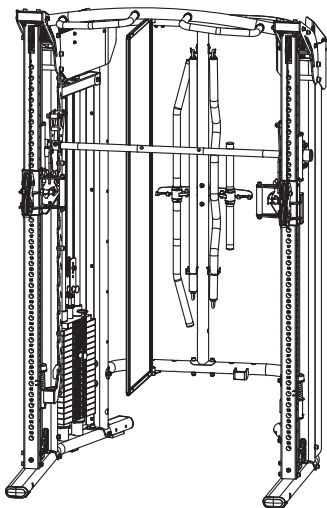
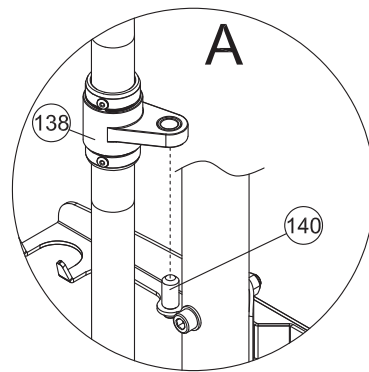
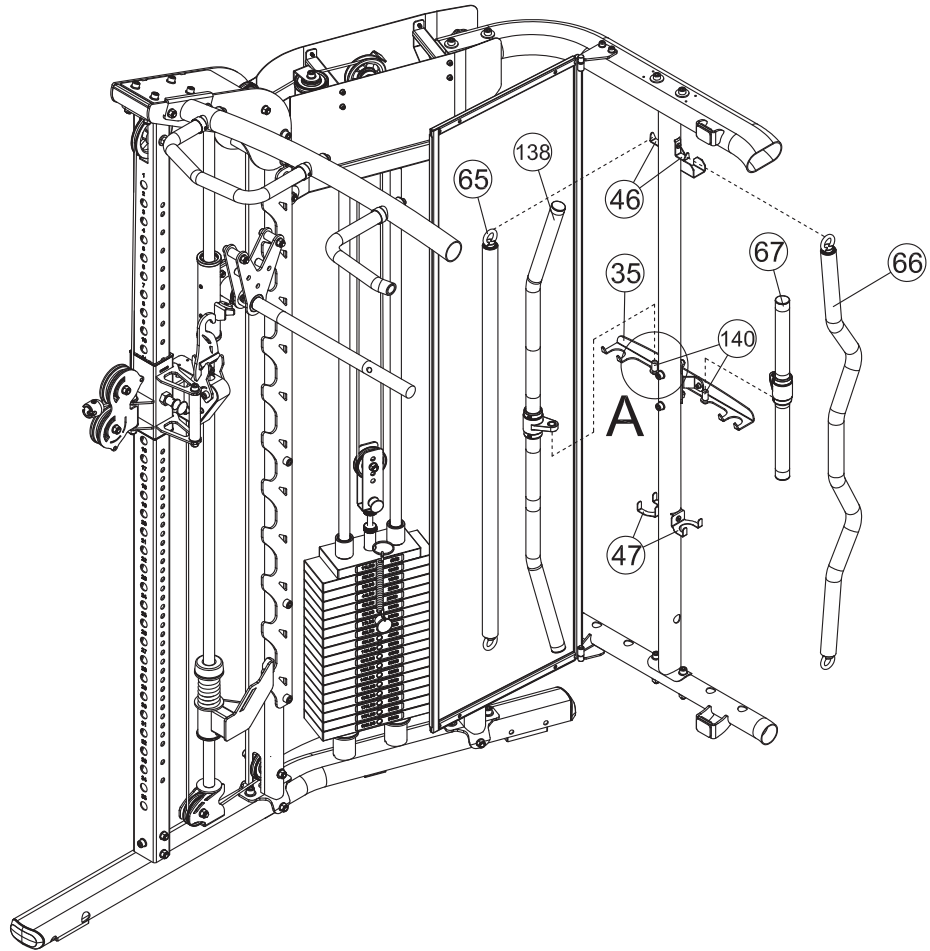
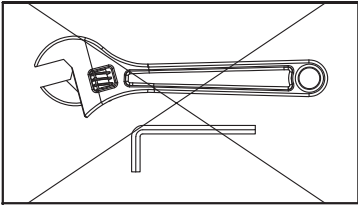

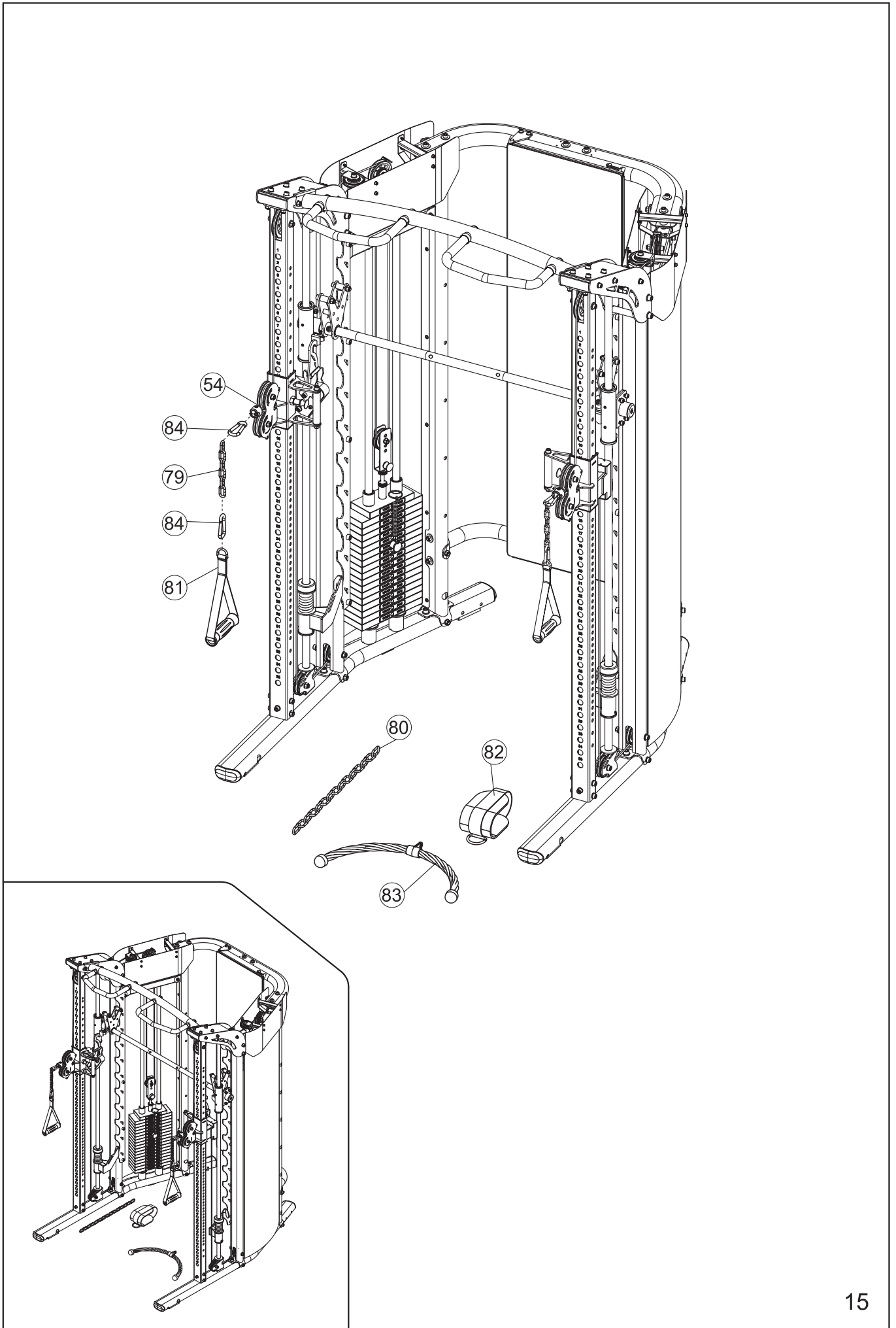

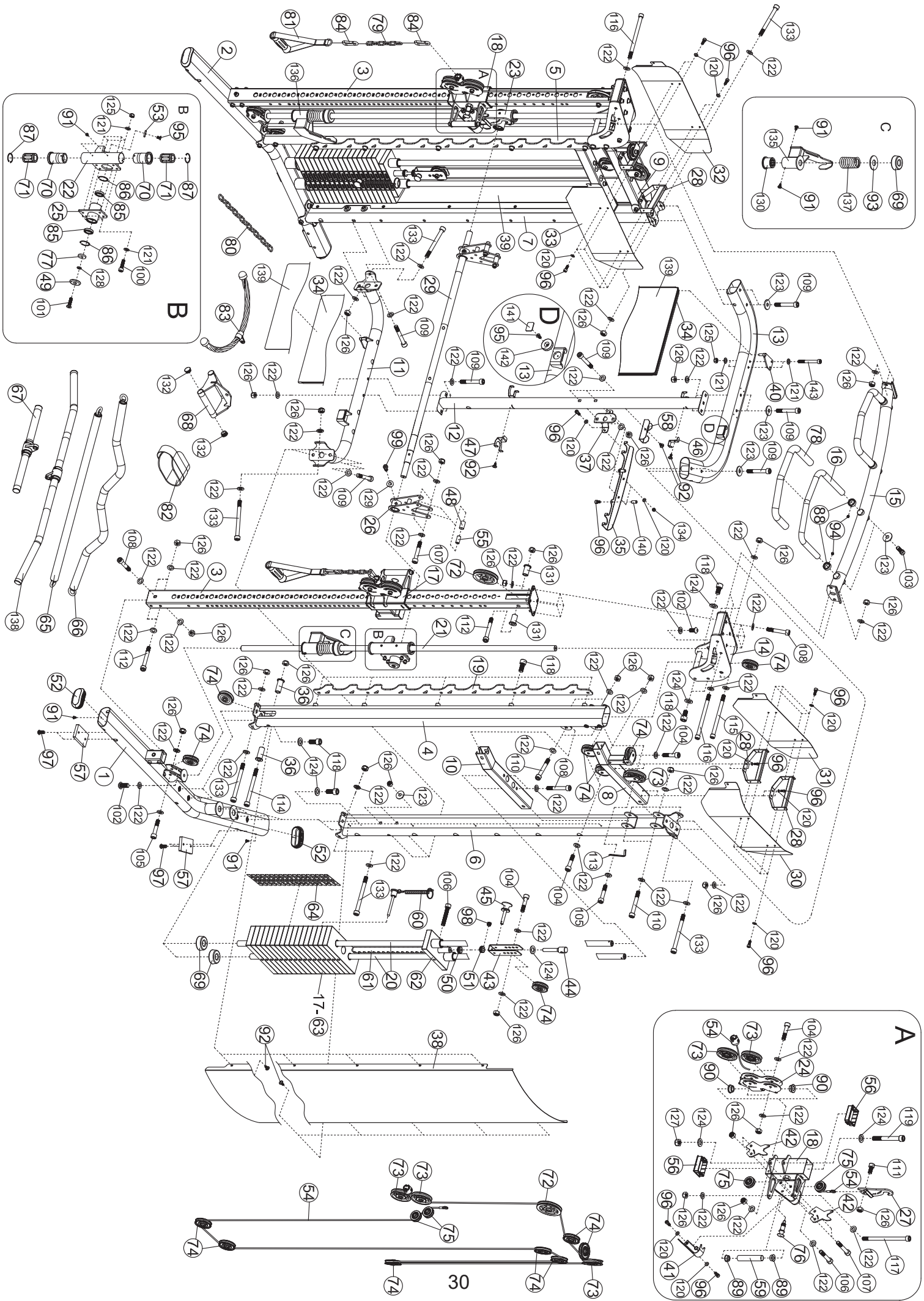

## PARTS LIST

KEY NO.	PART DESCRIPTION	SPEC	QTY
1	Base Frame L		1
2	Base Frame R		1
3	Guide Shaft		2
4	Front Post L		1
5	Front Post R		1
6	Rear Post L		1
7	Rear Post R		1
8	Top Frame L		1
9	Top Frame R		1
10	Fixed Frame	□50×2× (480)	2
11	Lower Connecting Frame		1
12	Intermediate Frame		1
13	Upper Connecting Frame		1
14	Front Connecting Frame		2
15	Horizontal bar		1
16	Chin-up Bar		2
17	Sliding frame L		1
18	Sliding frame R		1
19	Plate	1470×92×5	2
20	Guide Rod Rear	φ25×1580	4
21	Guide Rod	φ25×1815	2
22	Mobile rack L		1
23	Mobile rack R		1
24	Pulley Case		2
25	Connecting Frame		2
26	Hanging Bracket		2
27	Lifting Frame		2
28	Inner Fixed Set		4
29	Weight Rod	φ30×1260×M8	1
30	Outer Guard Plate L	608×220×79×1.5	1
31	Inner Guard Plate L	560×220×28×1.5	1
32	Outer Guard Plate R	608×220×79×1.5	1
33	Inner Guard Plate R	560×220×28×1.5	1
34	Poster Frame		1

## PARTS LIST

KEY NO.	PART DESCRIPTION	SPEC	QTY
35	Shelf	430×50×35×3	1
36	Bushing	φ22×φ16×φ10.2×40	4
37	Supporting Frame		1
38	Cover L	1715×493×1	1
39	Cover R	1715×493×1	1
40	Connecting Frame		1
41	Small Cover Frame		2
42	Supporting Plate	122×79×5	4
43	Pulley Case	160×50×25×3	2
44	Adjusting Bolt	φ22×100×M12	2
45	Aluminum Alloy Pin		2
46	Upper Handle Fixing Base	50×42×16×2	2
47	Lower Handle Fixing Base	61×60×30×1.5	2
48	Stainless Bushing	φ20×1.5×33	4
49	Aluminum Alloy End Cover	φ50×φ9×6	2
50	Knurled Nut	φ28×12×M12	2
51	Adjusting Sleeve	φ28×φ12.5×12	2
52	End Cap	PT50×100×R95	4
53	Rack Liner	φ30×5	2
54	Pull cable	L=φ5×7170	2
55	Bushing	φ16×φ11×33	4
56	Hollow Sleeve	□60×80×2.0×□50×70	4
57	Rubber Stopper	65×100×12	4
58	Small Storage Rack	100×37×38×27×10×2	1
59	Knurled Handle	φ25×2×125	2
60	Weight Selector Pin		2
61	Selector Rod	φ25×513 (17+1)	2
62	Top Weight Plate	205×100×72	2
63	Weight Plate	280×100×25.4 (5KG)	34
64	Weight Plate Sticker(90kg)	119×17.5	2
65	Aluminum Straight Bar	L=1115mm	1
66	Aluminum Cambered Bar	L=1150mm	1
67	Aluminum Small Grip Bar	L=480mm	1
68	V-type handle		1

## PARTS LIST

KEY NO.	PART DESCRIPTION	SPEC	QTY
69	Rubber Stopper	φ62×φ24.5×25	6
70	Sliding Rod Guide	φ55×φ46×φ40×73	4
71	Linear Motion Bearing	LB254058	4
72	Pulley with Bearings	φ114×φ10	2
73	Pulley with Bearings	φ95×φ10	6
74	Pulley with Bearings	φ72×φ10	14
75	Pulley with Bearings	φ50×φ10	4
76	Moving Lock Pin		2
77	Inner Washer	φ30×φ9×4	2
78	Long Rubber Handle	φ24.5×580	2
79	6-Joint Chain		2
80	15-Joint Chain		1
81	Pulling Sleeve	L=245mm	2
82	Ankle Strap		1
83	Rope		1
84	Hook	φ8	4
85	Bearing	61905	4
86	Hole circlip	42	4
87	Hole circlip	d0=40	4
88	Hole circlip	φ35×φ26.2×14.5×M6	4
89	Bushing	φ25×φ21.8×φ10.5×12	4
90	Bushing	φ25×φ20×φ12.2×10	4
91	Screw	ST4.0×9	12
92	Screw	ST4.8×13	25
93	Plate	φ65×φ27×4	2
94	Set screw	M6×6	4
95	Screw	M4×10	4
96	Hexagon socket button head screws	M6×15	32
97	Allen Bolt	M8×16	8
98	Set screw	M8×8	2
99	Hexagon socket button head screws	M8×20	2
100	Hexagon socket button head screws	M8×30	8
101	Hexagon socket countersunk head screw	M8×30	2
102	Allen Bolt	M10×20	4

## PARTS LIST

KEY NO.	PART DESCRIPTION	SPEC	QTY
103	Hexagon socket button head screws	M10×25	4
104	Hexagon socket button head screws	M10×45	12
105	Hexagon socket button head screws	M10×50	4
106	Hexagon socket button head screws	M10×55	4
107	Hexagon socket button head screws	M10×60	8
108	Hexagon socket button head screws	M10×65	14
109	Hexagon socket button head screws	M10×70	14
110	Hexagon socket button head screws	M10×75	8
111	Hexagon socket button head screws	M10×20	2
112	Hexagon socket button head screws	M10×85	6
113	L-Plate	72×30×25×2.5	2
114	Hexagon socket button head screws	M10×115	2
115	Hexagon socket button head screws	M10×135	2
116	Hexagon socket button head screws	M10×140	4
117	Hexagon socket button head screws	M10×155	2
118	Hexagon socket button head screws	M12×25	26
119	Hexagon socket button head screws	M12×95	2
120	Washer	6	32
121	Washer	8	20
122	Washer	φ10	144
123	Washer	φ30×φ10.5×2.5	14
124	Washer	12	22
125	Nut	M8	10
126	Nut	M10	82
127	Nut	M12	2
128	Spring Washer	8	2
129	Bend Washer	20×R20×φ9	2
130	Sliding Sleeve	φ55×φ46×φ27×41	2
131	Pulley Bushing	φ25×φ10.2×24	4
132	End Cap	φ28	4
133	Hexagon socket button head screws	M10×125	8
134	Nut	M6	2
135	Safety Bracket L		1
136	Safety Bracket R		1



## PARTS LIST

KEY NO.	PART DESCRIPTION	SPEC	QTY
137	Spring	φ43×φ27×φ8×80	2
138	Aluminum Pull-down Bar		1
139	Mirror	1640×440	1
140	Spiale	φ12.7×25×M6	2
141	Rubber Bumper	43×33×3	2
142	Magnetic Washer	φ25×φ5×4	2
143	Hexagon socket button head screws	M8×70	2
	Allen wrench	3#	1
	Allen wrench	4#	1
	Allen wrench	5#	1
	Allen wrench	6#	1
	Allen wrench	8#	1
	Allen wrench	10#	1