

# SEEDORFF ACME

Corporation



# Hand Pieces and Power Supplies Catalog **2019**



2

1

B

B

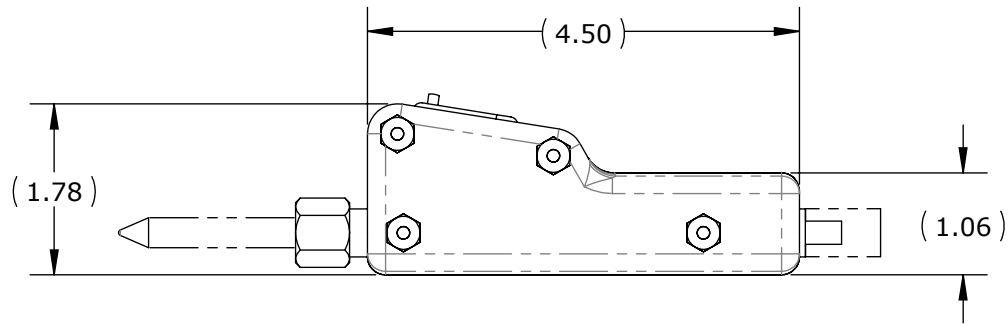

**MODEL DESCRIPTION:**  
 MINIATURE HAND PROBE TYPE SPOT WELD GUN WITH AIR COOLED CABLES.  
 DESIGNED TO SERVE LIGHT DUTY APPLICATIONS.

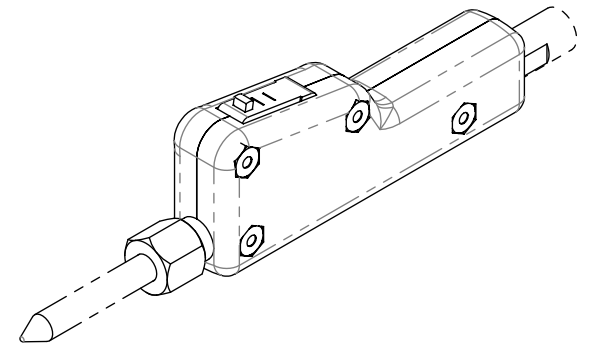

ELECTRODE IS SHOWN AS REFERENCE ONLY.

A

A

2

1

ALL INFORMATION CONTAINED IN THIS DOCUMENT IS PROPERTY OF SEEDORFF ACME CORP. AND MAY NOT BE REPRODUCED IN WHOLE OR PART WITHOUT PERMISSION OF SEEDORFF ACME CORP.

**SEEDORFF**

RESISTANCE WELDING EQUIPMENT  
 ANAHEIM, CA  
 SEEDORFFACME.COM

FEATHERLIGHT HAND PIECE

PART NO. 101852-001

DWG. NO. R00012

2

1

PART NUMBER	DESCRIPTION	LEGACY P/N
101384-001	LIGHT DUTY FORCE FIRED HAND PIECE - AC	5687A
101384-003	HEAVY DUTY FORCE FIRED HAND PIECE - AC	5687A
101384-005	LIGHT DUTY FORCE FIRED HAND PIECE - WC	5687A-WC
101384-007	HEAVY DUTY FORCE FIRED HAND PIECE - WC	5687A-WC

B

B

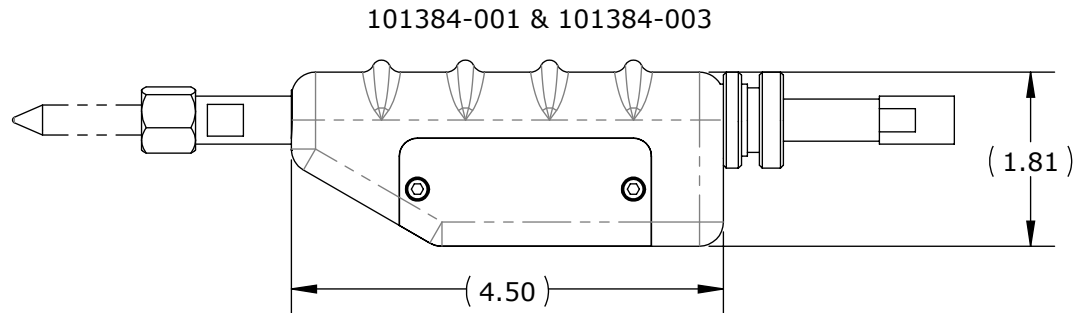

**MODEL DESCRIPTION:**  
 MINITURE PUSH TYPE SPOT WELD GUN. AIR COOLED CABLE.  
 INTERNAL FIRING SWITCH IS ACTUATED WHEN WELD GUN HAS REACHED  
 DESIRED WELDING PRESSURE. WELD PRESSURE IS SET AT REAR OF GUN.

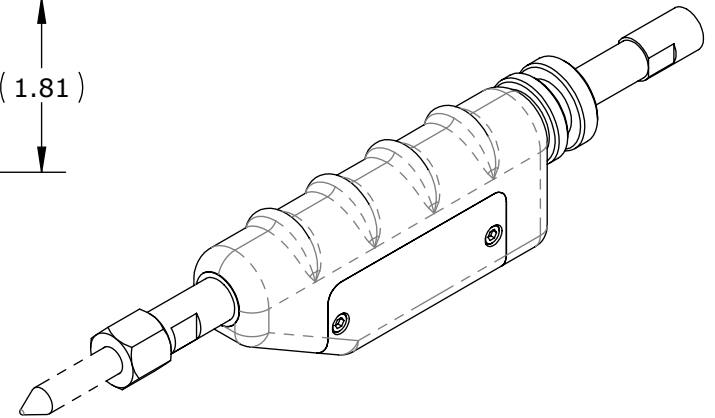

ELECTRODES ARE SHOWN AS REFERENCE ONLY.

101384-005 & 101384-007

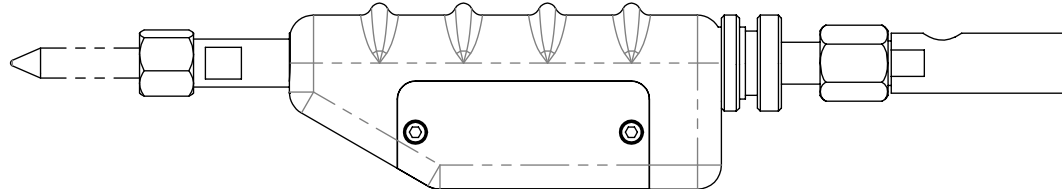

**MODEL DESCRIPTION:**  
 MINITURE PUSH TYPE SPOT WELD GUN. WATER COOLED CABLE.  
 INTERNAL FIRING SWITCH IS ACTUATED WHEN WELD GUN HAS REACHED  
 DESIRED WELDING PRESSURE. WELD PRESSURE IS SET AT REAR OF GUN.

A

A

ALL INFORMATION CONTAINED IN  
 THIS DOCUMENT IS PROPERTY OF  
 SEEDORFF ACME CORP. AND MAY  
 NOT BE REPRODUCED IN WHOLE  
 OR PART WITHOUT PERMISSION  
 OF SEEDORFF ACME CORP.

# SEEDORFF

RESISTANCE WELDING EQUIPMENT  
 ANAHEIM, CA  
 SEEDORFFACME.COM

FORCE FIRED HAND PIECE

PART NO. SEE TABLE

DWG. NO. R00007

2

1

2

1

PART NUMBER	DESCRIPTION	LEGACY P/N
101847-001	FORCE FIRED HAND PIECE - AC	5945E
101847-003	FORCE FIRED HAND PIECE - WC	5945E-WC

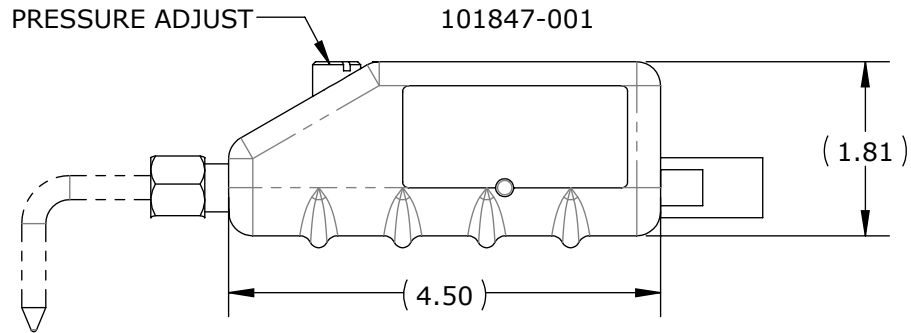
**MODEL DESCRIPTION**

MINIATURE PUSH TYPE SPOT WELDER GUN WITH AIR COOLED CABLE.  
INTERNAL FIRING SWITCH IS ACTUATED  
WHEN WELD GUN HAS REACHED DESIRED WELDING PRESSURE.  
WELD PRESSURE IS SET AT TOP OF GUN

DIRECTIONAL  
FORCE

101847-003

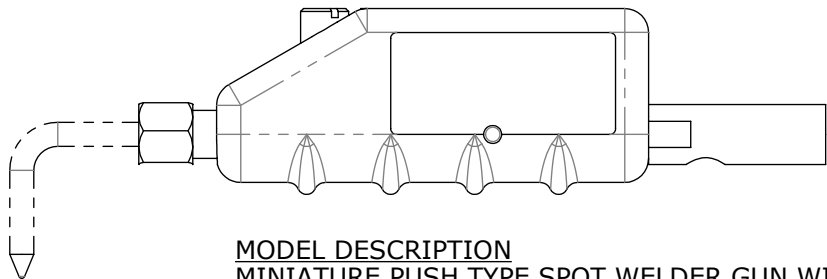
**MODEL DESCRIPTION**

MINIATURE PUSH TYPE SPOT WELDER GUN WITH WATER COOLED CABLE.  
INTERNAL FIRING SWITCH IS ACTUATED  
WHEN WELD GUN HAS REACHED DESIRED WELDING PRESSURE.  
WELD PRESSURE IS SET AT TOP OF GUN

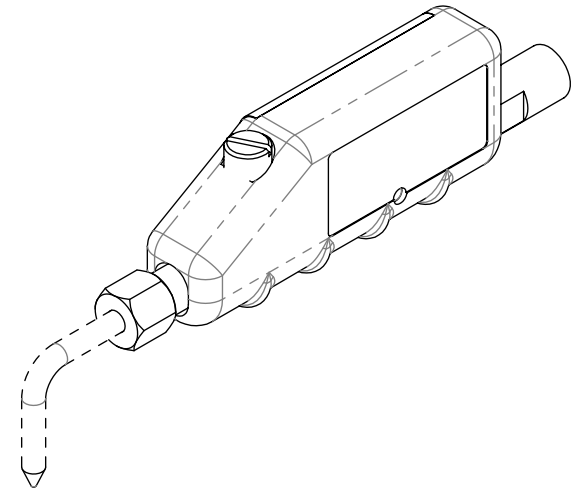

ELECTRODES ARE SHOWN AS REFERENCE ONLY.

**SEEDORFF**

RESISTANCE WELDING EQUIPMENT  
ANAHEIM, CA  
SEEDORFFACME.COM

FORCE FIRED HAND PIECE

PART NO. SEE TABLE

DWG. NO. R00009

ALL INFORMATION CONTAINED IN  
THIS DOCUMENT IS PROPERTY OF  
SEEDORFF ACME CORP. AND MAY  
NOT BE REPRODUCED IN WHOLE  
OR PART WITHOUT PERMISSION  
OF SEEDORFF ACME CORP.

2

1

2

1

B

B

**MODEL DESCRIPTION:**  
 MINIATURE PISTOL GRIP PROBE TYPE  
 SPOT WELD GUN WITH AIR COOLED CABLE.  
 DESIGNED TO SERVE LIGHT DUTY APPLICATIONS.

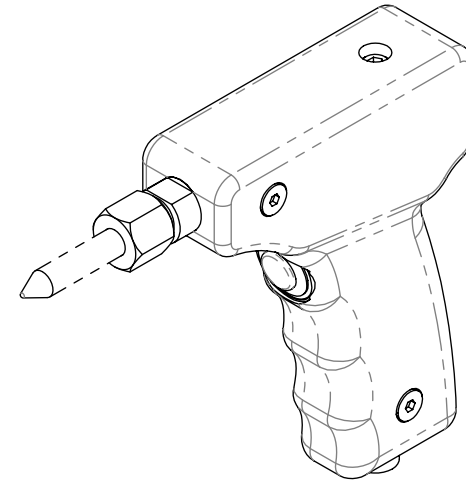
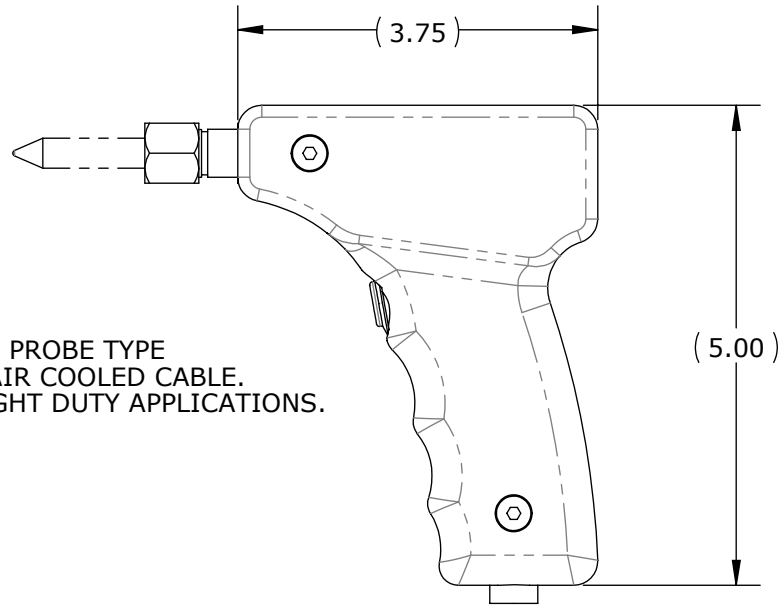

ELECTRODE IS SHOWN AS REFERENCE ONLY.

A

A

ALL INFORMATION CONTAINED IN  
 THIS DOCUMENT IS PROPERTY OF  
 SEEDORFF ACME CORP. AND MAY  
 NOT BE REPRODUCED IN WHOLE  
 OR PART WITHOUT PERMISSION  
 OF SEEDORFF ACME CORP.

**SEEDORFF**

RESISTANCE WELDING EQUIPMENT  
 ANAHEIM, CA  
 SEEDORFFACME.COM

PISTOL GRIP HAND PIECE

PART NO. 101220-001

DWG. NO. R00006

2

1

2

1

PART NUMBER	DESCRIPTION	LEGACY P/N
100147-001	PISTOL GRIP HAND PIECE - AC	8002-40
100147-003	PISTOL GRIP HAND PIECE - WC	8002-40-WC

B

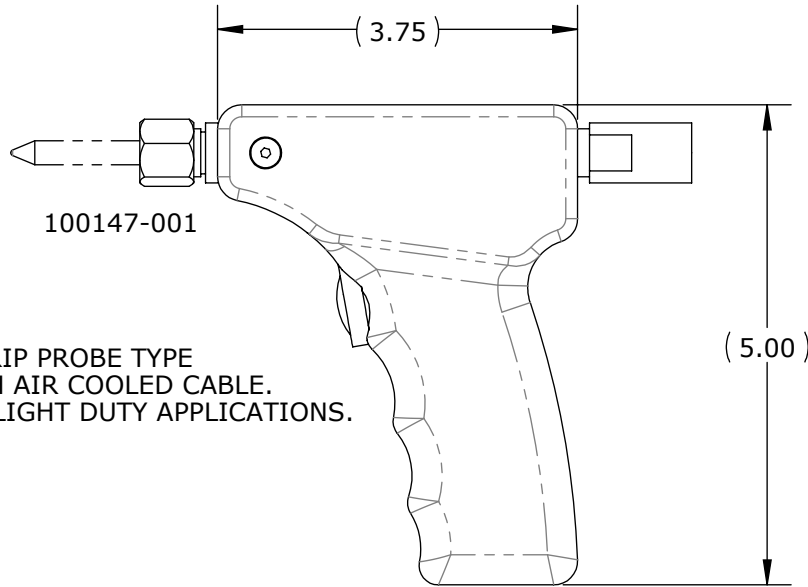

100147-001

**MODEL DESCRIPTION:**  
 MINIATURE PISTOL GRIP PROBE TYPE  
 SPOT WELD GUN WITH AIR COOLED CABLE.  
 DESIGNED TO SERVE LIGHT DUTY APPLICATIONS.

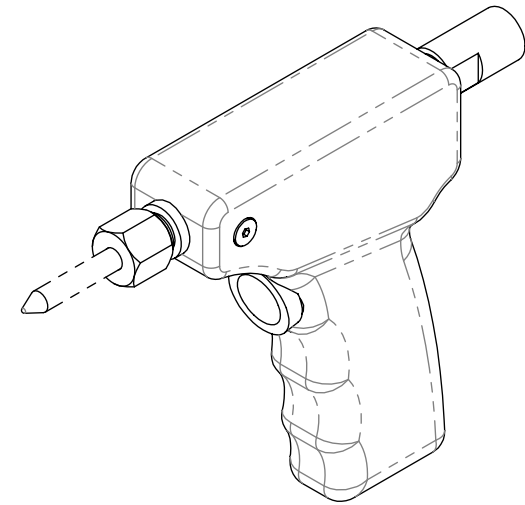

B

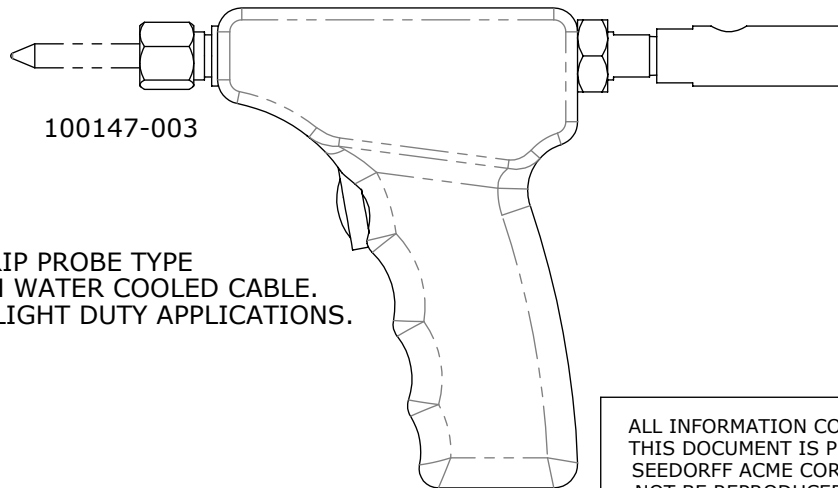

100147-003

**MODEL DESCRIPTION:**  
 MINIATURE PISTOL GRIP PROBE TYPE  
 SPOT WELD GUN WITH WATER COOLED CABLE.  
 DESIGNED TO SERVE LIGHT DUTY APPLICATIONS.

ELECTRODES ARE SHOWN AS REFERENCE ONLY.

A

A

ALL INFORMATION CONTAINED IN THIS DOCUMENT IS PROPERTY OF SEEDORFF ACME CORP. AND MAY NOT BE REPRODUCED IN WHOLE OR PART WITHOUT PERMISSION OF SEEDORFF ACME CORP.

**SEEDORFF**

RESISTANCE WELDING EQUIPMENT  
 ANAHEIM, CA  
 SEEDORFFACME.COM

PISTOL GRIP HAND PIECE

PART NO.

SEE TABLE

DWG. NO.

R00005

2

1

2

1

PART NUMBER	DESCRIPTION	LEGACY P/N
101794-001	PNEUMATIC HAND PIECE - AC	5803
101794-003	PNEUMATIC HAND PIECE - WC	5803-WC

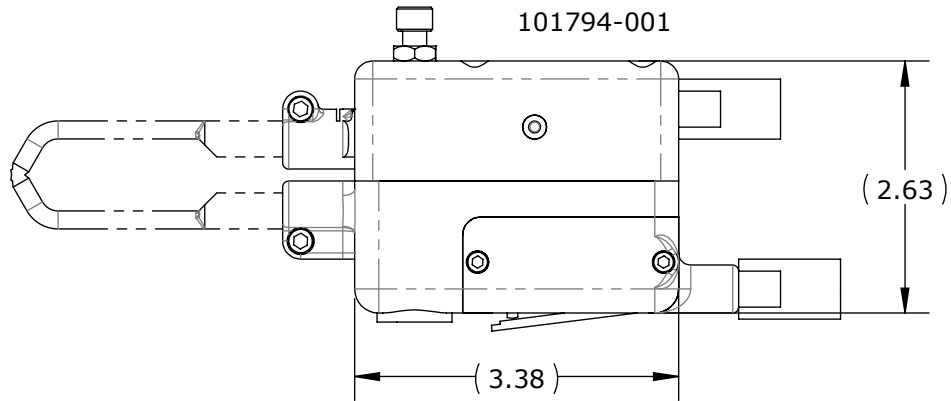

**MODEL DESCRIPTION:**  
 20 OZ. PNEUMATIC MINIATURE SCISSOR GUN  
 WITH AIR COOLED CABLES AND ADJUSTABLE STROKE.  
 ELECTRODE FORCE = 15 LBS. AT 80 P.S.I.

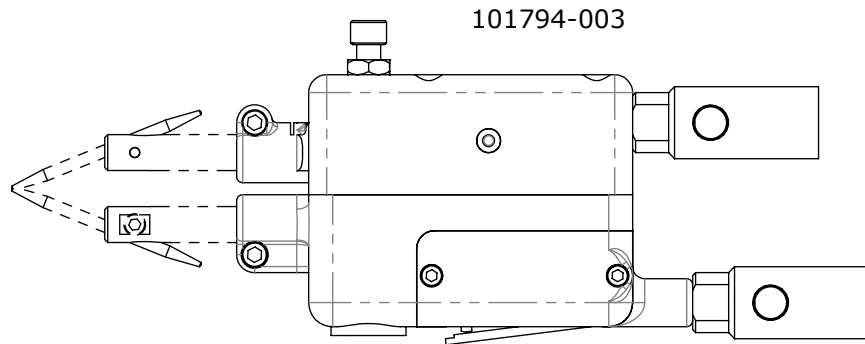

**MODEL DESCRIPTION:**  
 20 OZ. PNEUMATIC MINIATURE SCISSOR GUN  
 WITH WATER COOLED CABLES AND ADJUSTABLE STROKE.  
 ELECTRODE FORCE = 15 LBS. AT 80 P.S.I.

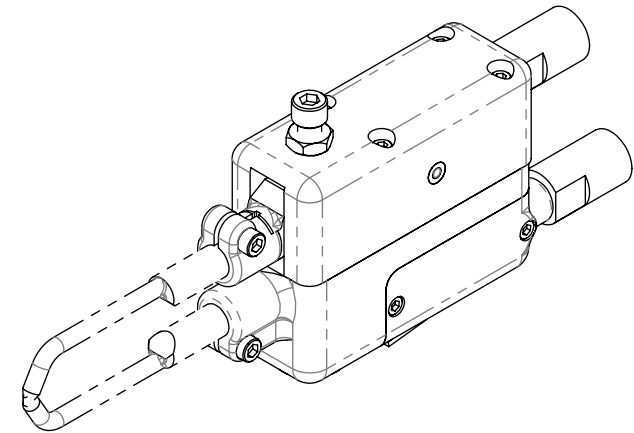

ELECTRODES ARE SHOWN AS REFERENCE ONLY.

ALL INFORMATION CONTAINED IN  
 THIS DOCUMENT IS PROPERTY OF  
 SEEDORFF ACME CORP. AND MAY  
 NOT BE REPRODUCED IN WHOLE  
 OR PART WITHOUT PERMISSION  
 OF SEEDORFF ACME CORP.

# SEEDORFF

RESISTANCE WELDING EQUIPMENT  
 ANAHEIM, CA  
 SEEDORFFACME.COM

PNEUMATIC HAND PIECE

PART NO. SEE TABLE

DWG. NO. R00004

2

1

2

1

PART NUMBER	DESCRIPTION	LEGACY P/N
101850-001	PNEUMATIC HAND PIECE - AC	5808
101850-003	PNEUMATIC HAND PIECE - WC	5808-WC

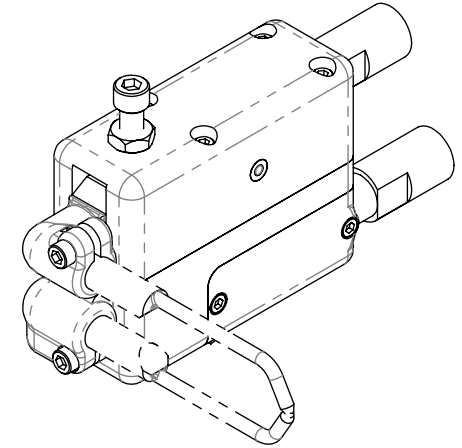
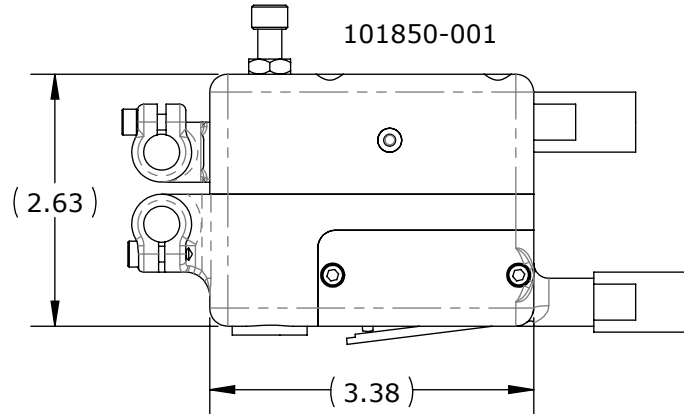
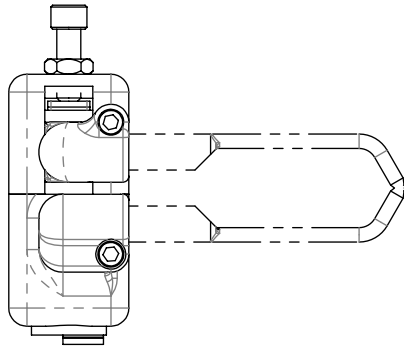
**MODEL DESCRIPTION**

20 OZ. PNEUMATIC MINIATURE SCISSOR GUN.  
RIGHT ANGLED, WITH AIR COOLED CABLE S AND ADJUSTABLE STROKE.  
ELECTRODE PRESSURE = 15 LBS. AT 80 P.S.I.

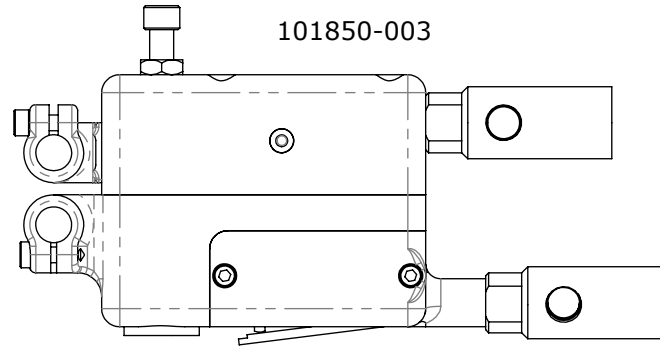
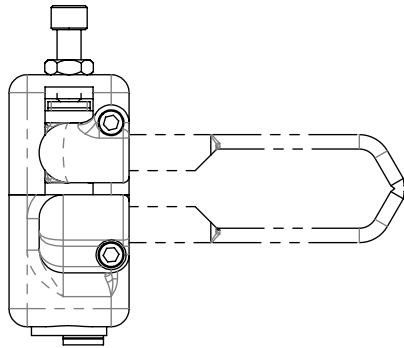

ELECTRODES ARE SHOWN AS REFERENCE ONLY.

**MODEL DESCRIPTION**

20 OZ. PNEUMATIC MINIATURE SCISSOR GUN.  
RIGHT ANGLED, WITH WATER COOLED CABLE S AND ADJUSTABLE STROKE.  
ELECTRODE PRESSURE = 15 LBS. AT 80 P.S.I.

ALL INFORMATION CONTAINED IN THIS DOCUMENT IS PROPERTY OF SEEDORFF ACME CORP. AND MAY NOT BE REPRODUCED IN WHOLE OR PART WITHOUT PERMISSION OF SEEDORFF ACME CORP.

# SEEDORFF

RESISTANCE WELDING EQUIPMENT  
ANAHEIM, CA  
SEEDORFFACME.COM

PNEUMATIC HAND PIECE

PART NO. SEE TABLE

DWG. NO. R00010

2

1



2

1

PART NUMBER	DESCRIPTION	LEGACY P/N
101851-001	PNEUMATIC HAND PIECE - AC	5689
101851-003	PNEUMATIC HAND PIECE - WC	5689-WC

B

B

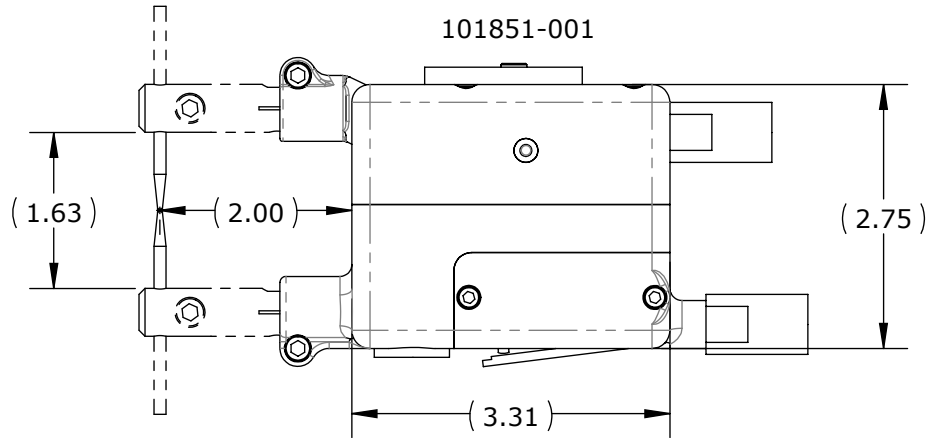

**MODEL DESCRIPTION:**  
 20 OZ. PNEUMATIC MINATURE SCISSOR GUN  
 WITH AIR COOLED CABLES AND ADJUSTABLE STROKE.  
 ELECTRODE FORCE = 15 LBS. AT 80 P.S.I.

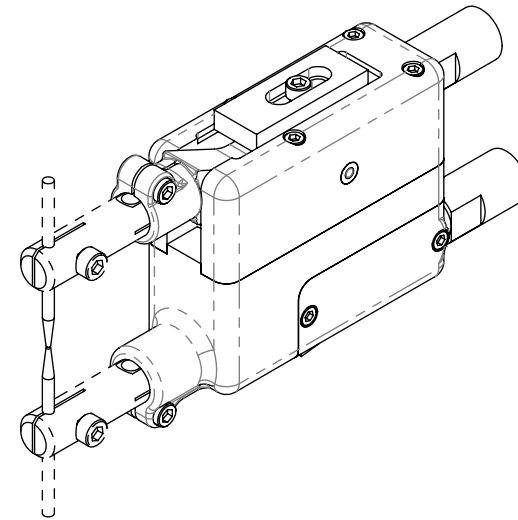

ELECTRODES ARE SHOWN AS REFERENCE ONLY.

A

A

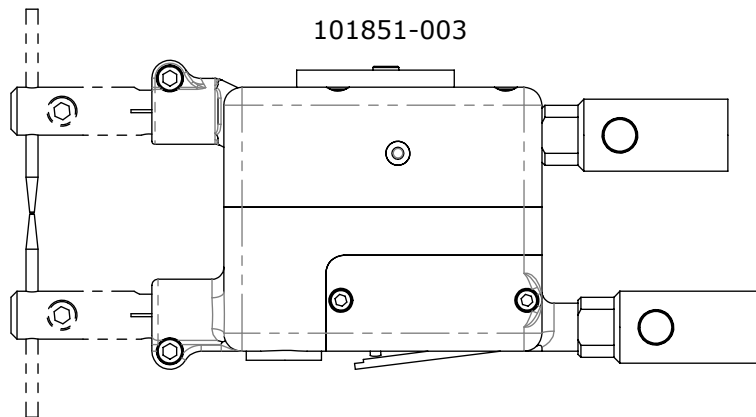

**MODEL DESCRIPTION:**  
 20 OZ. PNEUMATIC MINATURE SCISSOR GUN  
 WITH WATER COOLED CABLES AND ADJUSTABLE STROKE.  
 ELECTRODE FORCE = 15 LBS. AT 80 P.S.I.

ALL INFORMATION CONTAINED IN THIS DOCUMENT IS PROPERTY OF SEEDORFF ACME CORP. AND MAY NOT BE REPRODUCED IN WHOLE OR PART WITHOUT PERMISSION OF SEEDORFF ACME CORP.

**SEEDORFF**

RESISTANCE WELDING EQUIPMENT  
 ANAHEIM, CA  
 SEEDORFFACME.COM

PNEUMATIC HAND PIECE

PART NO. SEE TABLE

DWG. NO. R00011

2

1

2

1

PART NUMBER	DESCRIPTION	LEGACY P/N
101749-001	PNEUMATIC HAND PIECE - AC	7130
101749-003	PNEUMATIC HAND PIECE - WC	7130-WC

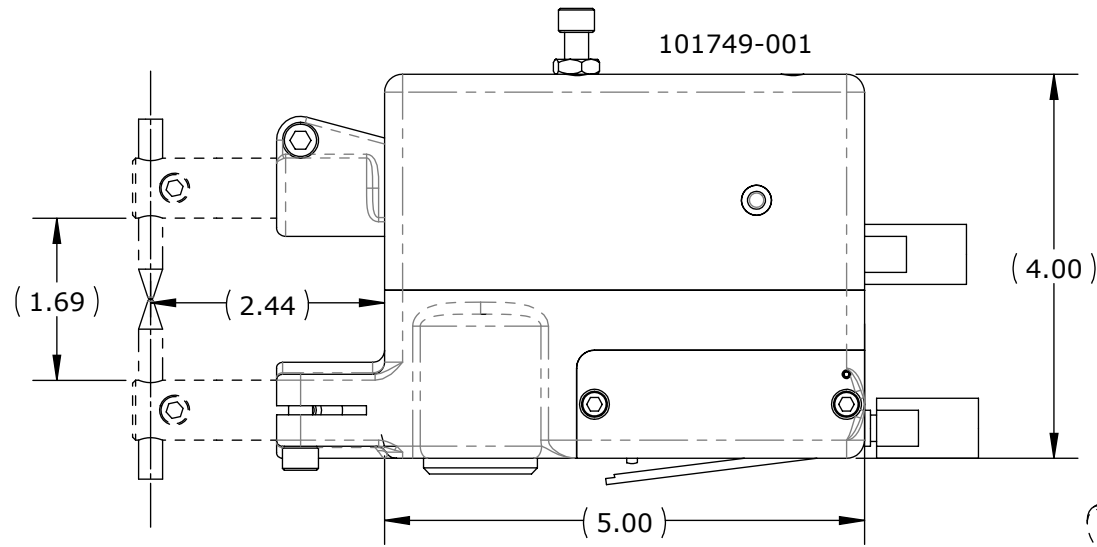

**MODEL DESCRIPTION:**  
 PNEUMATIC MINIATURE SCISSOR GUN WITH AIR COOLED  
 AND ADJUSTABLE STROKE.  
 ELECTRODE FORCE = 60 LBS. AT 80 P.S.I.

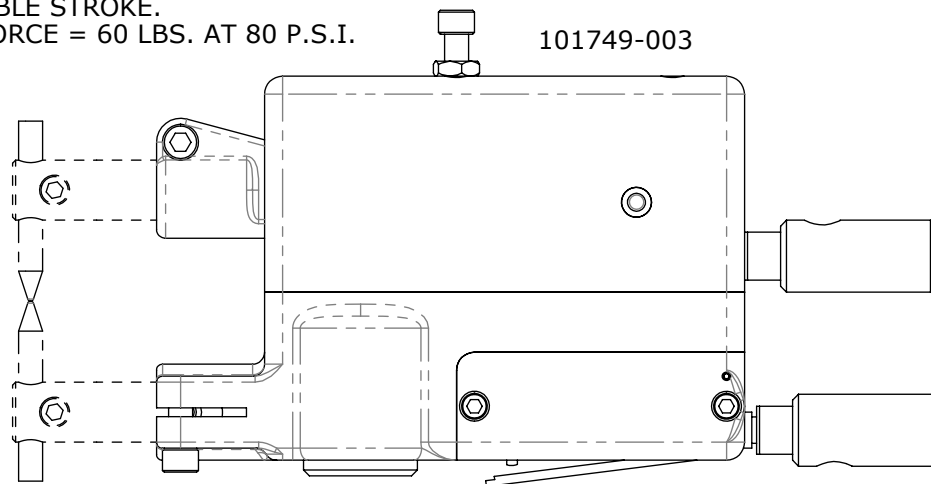

**MODEL DESCRIPTION:**  
 PNEUMATIC MINIATURE SCISSOR GUN WITH WATER COOLED  
 AND ADJUSTABLE STROKE.  
 ELECTRODE FORCE = 60 LBS. AT 80 P.S.I.

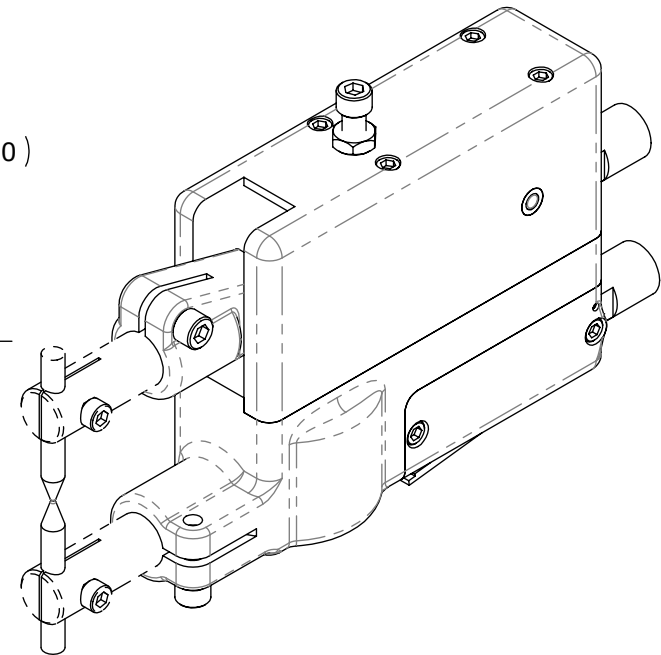

ELECTRODES ARE SHOWN AS REFERENCE ONLY.

ALL INFORMATION CONTAINED IN  
 THIS DOCUMENT IS PROPERTY OF  
 SEEDORFF ACME CORP. AND MAY  
 NOT BE REPRODUCED IN WHOLE  
 OR PART WITHOUT PERMISSION  
 OF SEEDORFF ACME CORP.

# SEEDORFF

RESISTANCE WELDING EQUIPMENT  
 ANAHEIM, CA  
 SEEDORFFACME.COM

PNEUMATIC HAND PIECE

PART NO.	SEE TABLE
DWG. NO.	R00008

2

1

2

1

PART NUMBER	DESCRIPTION	LEGACY P/N
101823-003	Ø.188 ANGLED H.P. ELECTRODE - CL.2	2124-S
102767-003	Ø.188 ANGLED H.P. ELECTRODE - CL.3	N/A

B

B

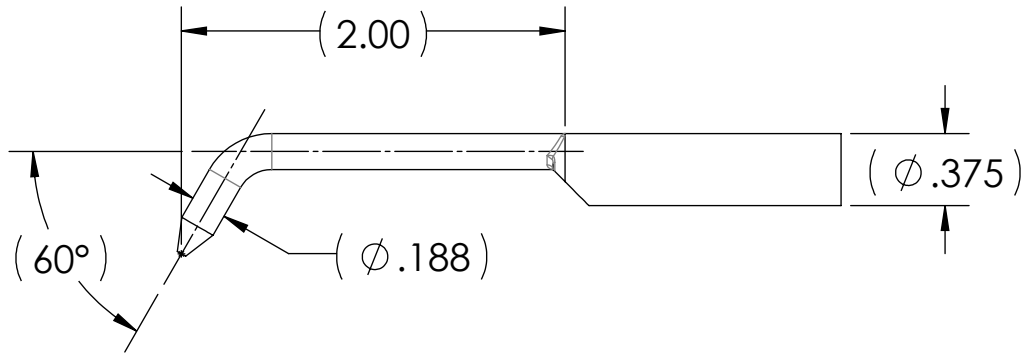
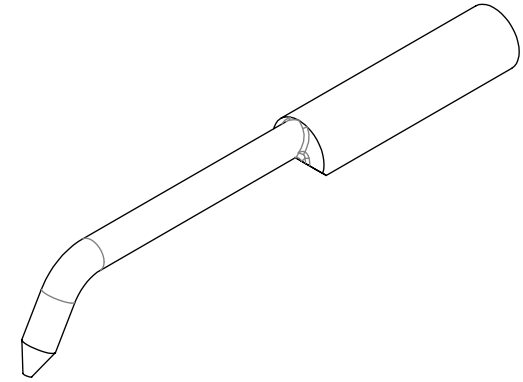

**ELECTRODE DESCRIPTION**  
 Ø.188 ANGLED HAND PIECE COPPER ELECTRODES.  
 CUSTOM DIAMETER AND LENGTH ARE AVAILABLE.

A

A

**SEEDORFF**

RESISTANCE WELDING EQUIPMENT  
 ANAHEIM, CA  
 SEEDORFFACME.COM

ANGLED H. P. ELECTRODES

PART NO. SEE TABLE

DWG. NO. R00021

ALL INFORMATION CONTAINED IN THIS DOCUMENT IS PROPERTY OF SEEDORFF ACME CORP. AND MAY NOT BE REPRODUCED IN WHOLE OR PART WITHOUT PERMISSION OF SEEDORFF ACME CORP.

2

1

2

1

PART NUMBER	DESCRIPTION	LEGACY P/N
102755-001	Ø.125 STRAIGHT H.P. ELECTRODE - CL.2	2112-.125-1.25-R
102756-001	Ø.125 STRAIGHT H.P. ELECTRODE - CL.3	N/A
102757-001	Ø.250 STRAIGHT H.P. ELECTRODE - CL.2	2112-.250-1.25-R
102758-001	Ø.250 STRAIGHT H.P. ELECTRODE - CL.3	N/A

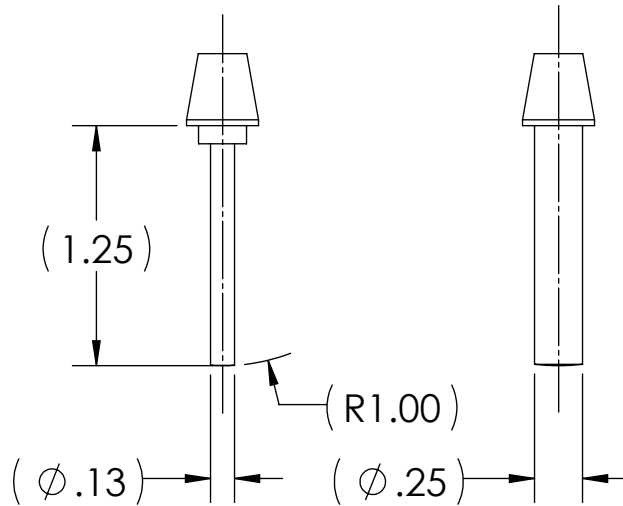
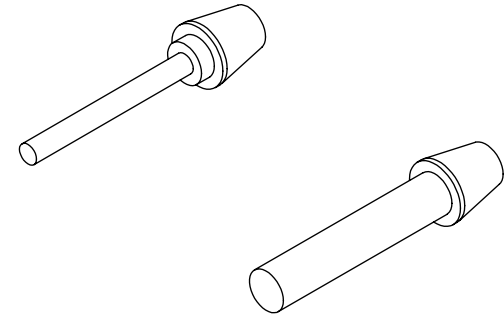

**ELECTRODE DESCRIPTION**  
 STRAIGHT HAND PIECE COPPER ELECTRODES W/ 1.00" RAIDUS.  
 CUSTOM DIAMETER AND LENGTH ARE AVAILABLE.

<b>SEEDORFF</b> RESISTANCE WELDING EQUIPMENT ANAHEIM, CA SEEDORFFACME.COM	
STRAIGHT H. P. ELECTRODE	
PART NO.	SEE TABLE
DWG. NO.	R00022

ALL INFORMATION CONTAINED IN THIS DOCUMENT IS PROPERTY OF SEEDORFF ACME CORP. AND MAY NOT BE REPRODUCED IN WHOLE OR PART WITHOUT PERMISSION OF SEEDORFF ACME CORP.

2

1

B

B

A

A

2

1

PART NUMBER	DESCRIPTION	LEGACY P/N
101626-001	Ø.125 DOUBLE ENDED ELECTRODE - CL.2	N/A
101627-001	Ø.125 DOUBLE ENDED ELECTRODE - CL.3	N/A

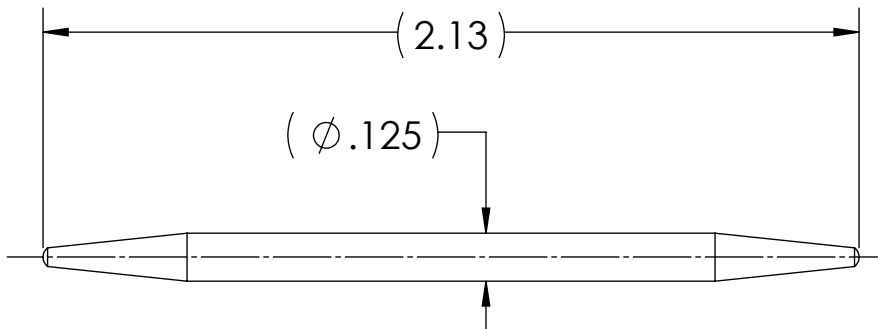
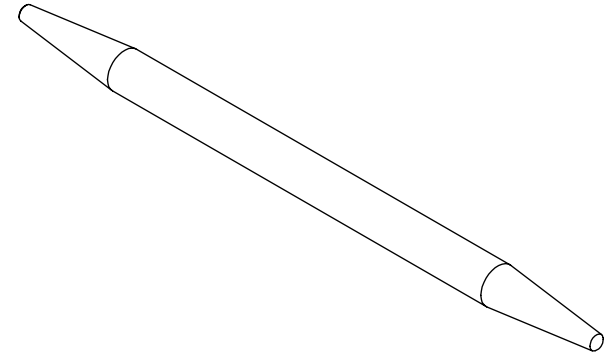

ELECTRODE DESCRIPTION  
 DOUBLE ENDED HAND PIECE COPPER ELECTRODES.  
 CUSTOM DIAMETER AND LENGTH ARE AVAILABLE.

ALL INFORMATION CONTAINED IN THIS DOCUMENT IS PROPERTY OF SEEDORFF ACME CORP. AND MAY NOT BE REPRODUCED IN WHOLE OR PART WITHOUT PERMISSION OF SEEDORFF ACME CORP.

<b>SEEDORFF</b>	
RESISTANCE WELDING EQUIPMENT ANAHEIM, CA SEEDORFFACME.COM	
DOUBLE ENDED H. P. ELECTRODES	
PART NO.	SEE TABLE
DWG. NO.	R00023

2

1

B

B

A

A

2

1

PART NUMBER	DESCRIPTION	LEGACY P/N
102759-001	Ø.125 STRAIGHT HP ELECTRODE - CL.2	2112-.125-1.25
102760-001	Ø.125 STRAIGHT HP ELECTRODE - CL.3	N/A
102761-001	Ø.250 STRAIGHT HP ELECTRODE - CL.2	2112-.250-1.25
102762-001	Ø.250 STRAIGHT HP ELECTRODE - CL.3	N/A

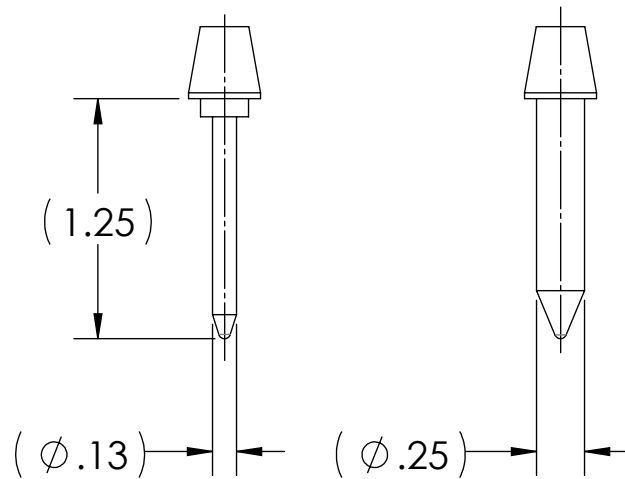
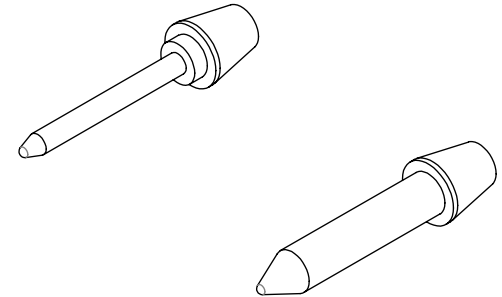

**ELECTRODE DESCRIPTION**  
 STRAIGHT HAND PIECE COPPER ELECTRODES.  
 CUSTOM DIAMETER AND LENGTH ARE AVAILABLE.

ALL INFORMATION CONTAINED IN  
 THIS DOCUMENT IS PROPERTY OF  
 SEEDORFF ACME CORP. AND MAY  
 NOT BE REPRODUCED IN WHOLE  
 OR PART WITHOUT PERMISSION  
 OF SEEDORFF ACME CORP.

# SEEDORFF

RESISTANCE WELDING EQUIPMENT  
 ANAHEIM, CA  
 SEEDORFFACME.COM

STRAIGHT H. P. ELECTRODES

PART NO. SEE TABLE

DWG. NO. R00024

2

1

2

1

PART NUMBER	DESCRIPTION	LEGACY P/N
101729-001	Ø.250 ELECTRODE - CL.2	2165
102768-001	Ø.250 ELECTRODE - CL.3	N/A

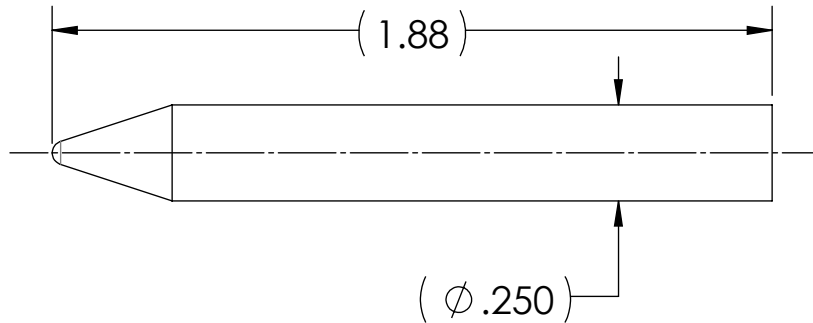
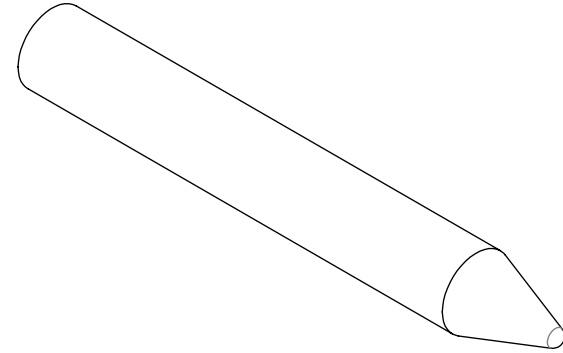

**ELECTRODE DESCRIPTION**  
 Ø.250 HAND PIECE COPPER ELECTRODES.  
 CUSTOM DIAMETER AND LENGTH ARE AVAILABLE.

B

B

A

A

2

1

ALL INFORMATION CONTAINED IN THIS DOCUMENT IS PROPERTY OF SEEDORFF ACME CORP. AND MAY NOT BE REPRODUCED IN WHOLE OR PART WITHOUT PERMISSION OF SEEDORFF ACME CORP.

<b>SEEDORFF</b>	
RESISTANCE WELDING EQUIPMENT ANAHEIM, CA SEEDORFFACME.COM	
H. P. ELECTRODE	
PART NO.	SEE TABLE
DWG. NO.	R00025

2

1

PART NUMBER	DESCRIPTION	LEGACY P/N
102765-001	90° ANGLE H.P. ELECTRODE -CL.2	2268-.250-1.37-90°
102763-001	90° ANGLE H.P. ELECTRODE -CL.3	N/A
102766-001	35° ANGLE H.P. ELECTRODE - CL.2	2268-.250-2.00-35°
102764-001	35° ANGLE H.P. ELECTRODE - CL.3	N/A

B

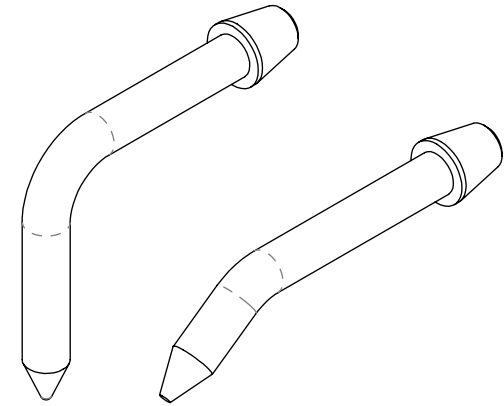
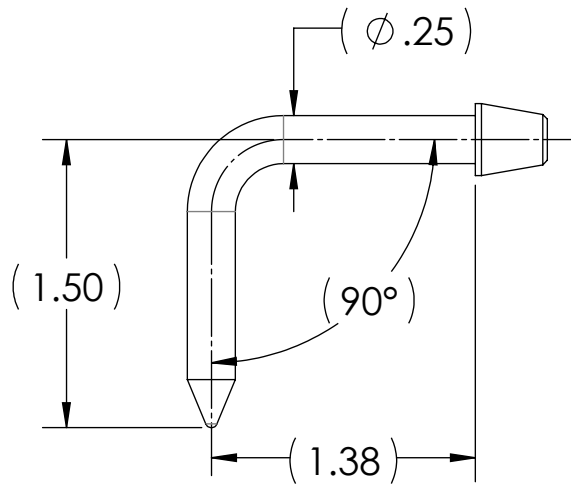

B

**ELECTRODE DESCRIPTION**  
 Ø.250 ANGLED HAND PIECE COPPER ELECTRODES.  
 CUSTOM DIAMETER AND LENGTH ARE AVAILABLE.

A

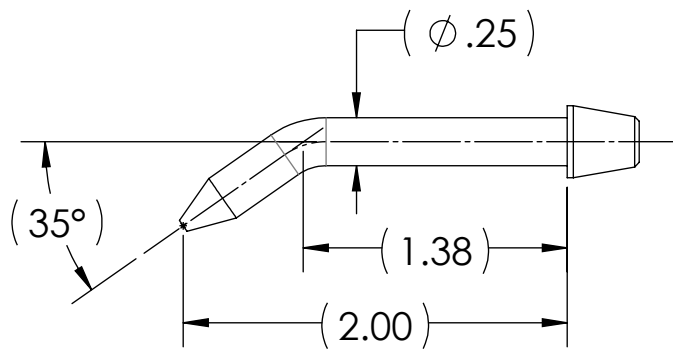

A

**SEEDORFF**

RESISTANCE WELDING EQUIPMENT  
 ANAHEIM, CA  
 SEEDORFFACME.COM

ANGLED H. P. ELECTRODE

PART NO. SEE TABLE

DWG. NO. R00026

ALL INFORMATION CONTAINED IN THIS DOCUMENT IS PROPERTY OF SEEDORFF ACME CORP. AND MAY NOT BE REPRODUCED IN WHOLE OR PART WITHOUT PERMISSION OF SEEDORFF ACME CORP.

2

1



2

1

REVISIONS			
REV	DESCRIPTION	DATE	APPR.

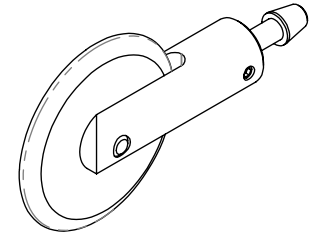
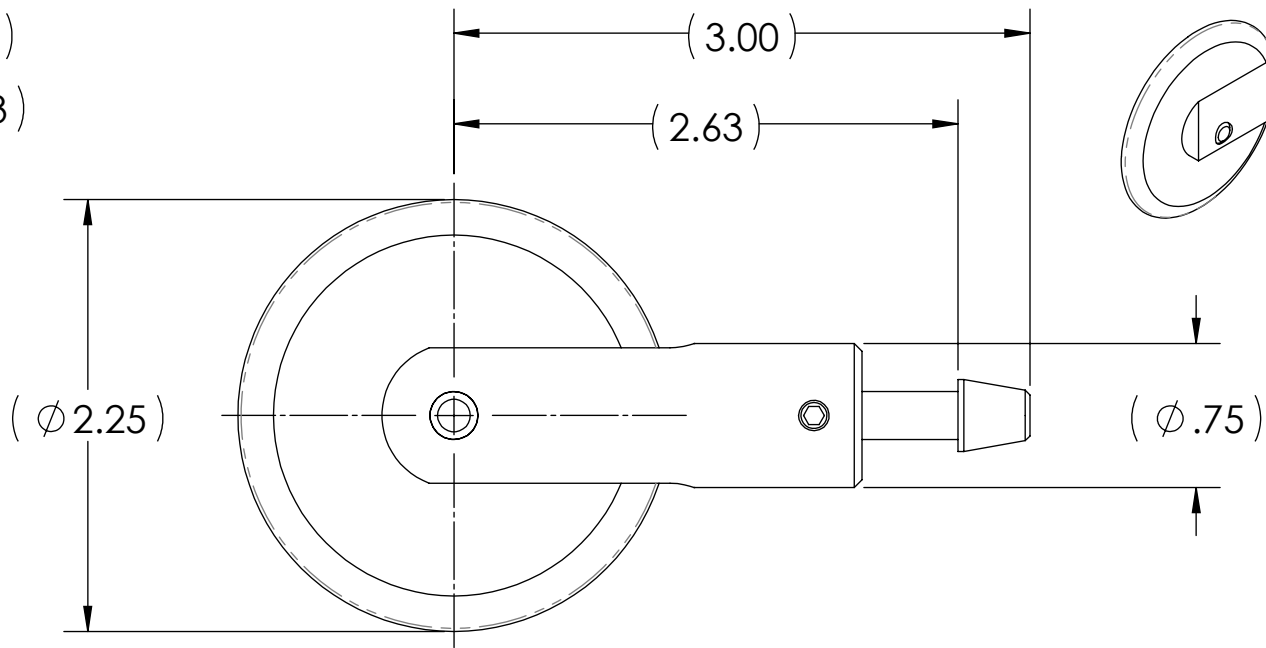
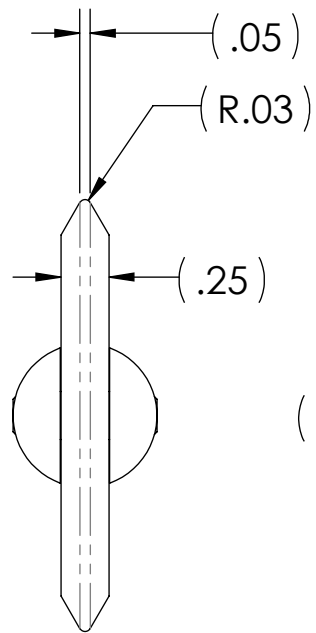

B

B

A

A

GENERAL NOTES:  
 1. SHOWN DIMENSIONS ARE ONLY FOR REFERENCE

ALL INFORMATION CONTAINED IN THIS DOCUMENT IS PROPERTY OF SEEDORFF ACME CORP. AND MAY NOT BE REPRODUCED IN WHOLE OR PART WITHOUT PERMISSION OF SEEDORFF ACME CORP.

# SEEDORFF

RESISTANCE WELDING EQUIPMENT  
 ANAHEIM, CA  
 SEEDORFFACME.COM

Ø2.25 ROLL WELD WHEEL ASSEMBLY

PART NO.	103259-001
DWG. NO.	R00060

2

1

2

1

PART NUMBER	DESCRIPTION	"L"	LEGACY P/N	WEIGHT
102743-001	#2 AIR COOLED WELDING CABLE ASS'Y - 1.00 m	1.00	1928-1-AC	1.17 LBS.
102743-003	#2 AIR COOLED WELDING CABLE ASS'Y - 2.00 m	2.00	1928-2-AC	2.23 LBS.
102743-005	#2 AIR COOLED WELDING CABLE ASS'Y - 3.00 m	3.00	1928-3-AC	3.29 LBS.

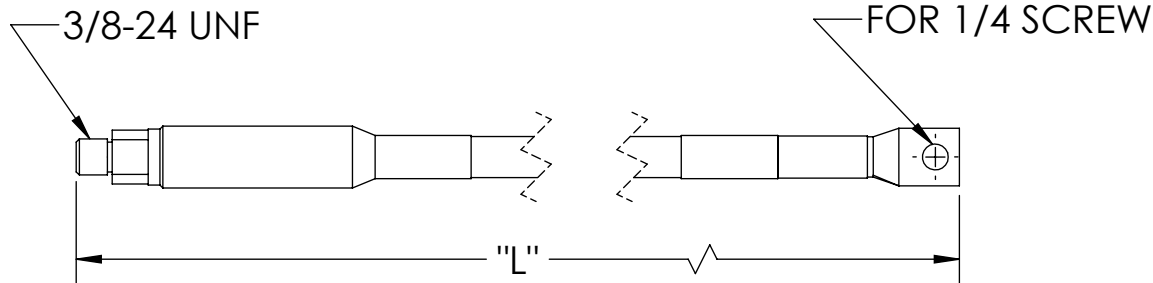
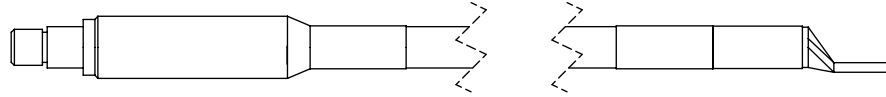
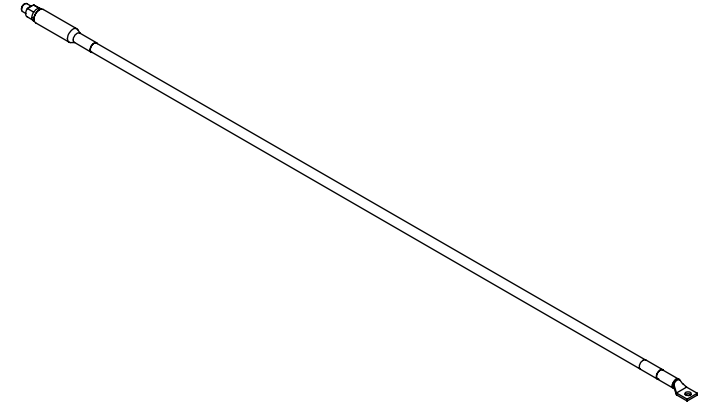

B

B

A

A

GENERAL NOTES:

1. "L" DIMENSION IS GIVEN IN METRIC UNIT "m"
2. CUSTOM LENGTH IS AVAILABLE

ALL INFORMATION CONTAINED IN THIS DOCUMENT IS PROPERTY OF SEEDORFF ACME CORP. AND MAY NOT BE REPRODUCED IN WHOLE OR PART WITHOUT PERMISSION OF SEEDORFF ACME CORP.

# SEEDORFF

RESISTANCE WELDING EQUIPMENT  
ANAHEIM, CA  
SEEDORFFACME.COM

#2 AIR COOLED WELDING CABLE ASS'Y

PART NO.	SEE TABLE
DWG. NO.	R00030

2

1

2

1

PART NUMBER	DESCRIPTION	"L"	LEGACY P/N	WEIGHT
102748-001	1/0 AIR COOLED WELDING CABLE ASS'Y - 1.00 m	1.00	1928-HD-1-AC	1.84 LBS.
102748-003	1/0 AIR COOLED WELDING CABLE ASS'Y - 2.00 m	2.00	1928-HD-2-AC	3.58 LBS.
102748-005	1/0 AIR COOLED WELDING CABLE ASS'Y - 3.00 m	3.00	1928-HD-3-AC	5.33 LBS.

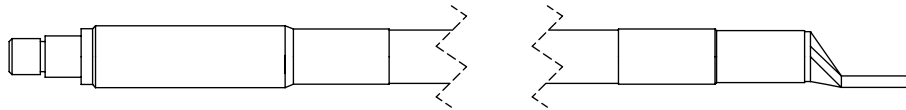
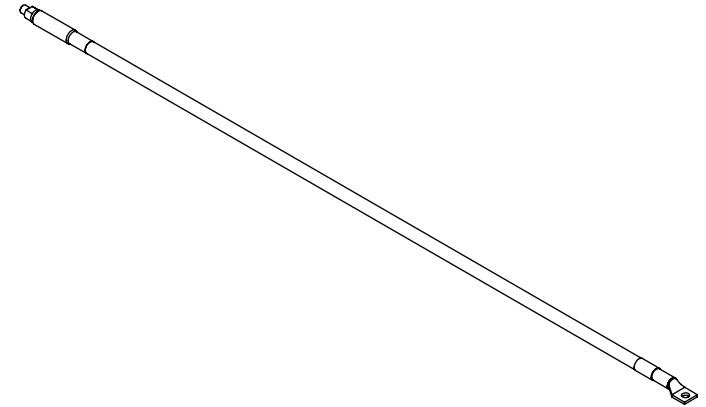

3/8-24 UNF

FOR 5/16 SCREW

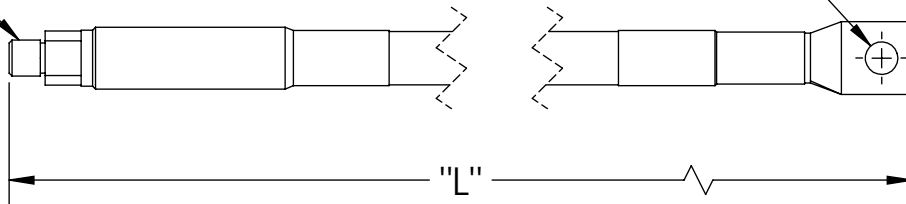

B

B

A

A

GENERAL NOTES:

- "L" DIMENSION IS GIVEN IN METRIC UNIT "m"
- CUSTOM LENGTH IS AVAILABLE

ALL INFORMATION CONTAINED IN THIS DOCUMENT IS PROPERTY OF SEEDORFF ACME CORP. AND MAY NOT BE REPRODUCED IN WHOLE OR PART WITHOUT PERMISSION OF SEEDORFF ACME CORP.

**SEEDORFF**

RESISTANCE WELDING EQUIPMENT  
ANAHEIM, CA  
SEEDORFFACME.COM

1/0 AIR COOLED WELDING CABLE ASS'Y

PART NO. SEE TABLE

DWG. NO. R00031

2

1

2

1

PART NUMBER	DESCRIPTION	"L"	LEGACY P/N	WEIGHT
102752-001	#4 WATER COOLED WELDING CALBE ASS'Y - 1.00 m	1.00	1933LD-A-1-WC	0.98 LBS.
102752-003	#4 WATER COOLED WELDING CALBE ASS'Y - 2.00 m	2.00	1933LD-A-2-WC	1.82 LBS.
102752-005	#4 WATER COOLED WELDING CALBE ASS'Y - 3.00 m	3.00	1933LD-A-3-WC	2.66 LBS.

B

B

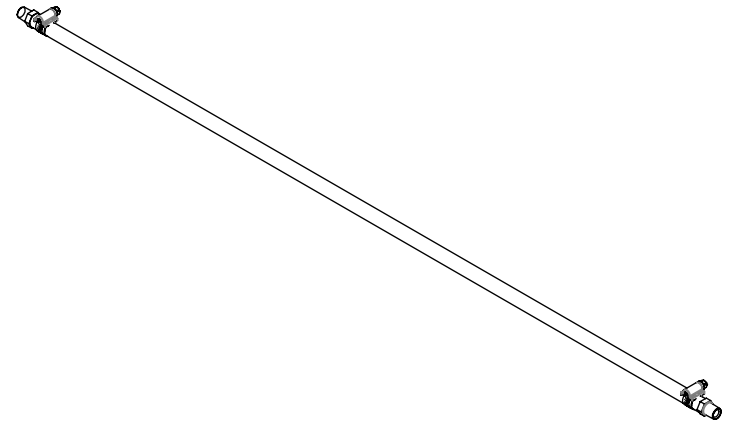
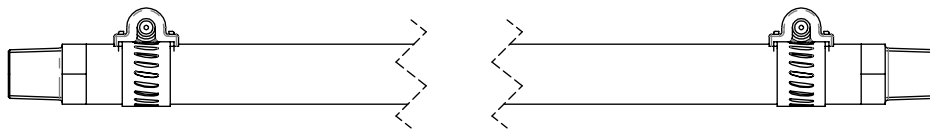

1/4 NPT

1/4 NPT

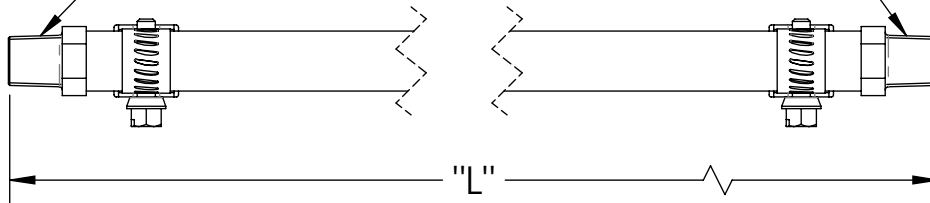

A

A

GENERAL NOTES:

1. "L" DIMENSION IS GIVEN IN METRIC UNIT "m"
2. CUSTOM LENGTH IS AVAILABLE

ALL INFORMATION CONTAINED IN THIS DOCUMENT IS PROPERTY OF SEEDORFF ACME CORP. AND MAY NOT BE REPRODUCED IN WHOLE OR PART WITHOUT PERMISSION OF SEEDORFF ACME CORP.

**SEEDORFF**

RESISTANCE WELDING EQUIPMENT  
ANAHEIM, CA  
SEEDORFFACME.COM

#4 WATER COOLED WELDING CABLE ASS'Y

PART NO.

SEE TABLE

DWG. NO.

R00032

2

1

2

1

PART NUMBER	DESCRIPTION	"L"	LEGACY P/N	WEIGHT
102754-001	2/0 WATER COOLED WELDING CALBE ASS'Y - 1.00 m	1.00	1933HD-A-1-WC	2.45 LBS.
102754-003	2/0 WATER COOLED WELDING CALBE ASS'Y - 2.00 m	2.00	1933HD-A-2-WC	*4.82 LBS.
102754-005	2/0 WATER COOLED WELDING CALBE ASS'Y - 3.00 m	3.00	1933HD-A-3-WC	7.18 LBS.

B

B

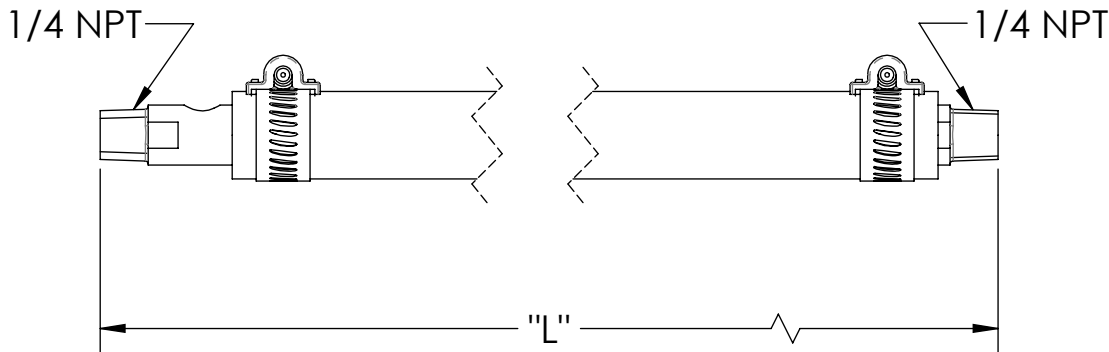
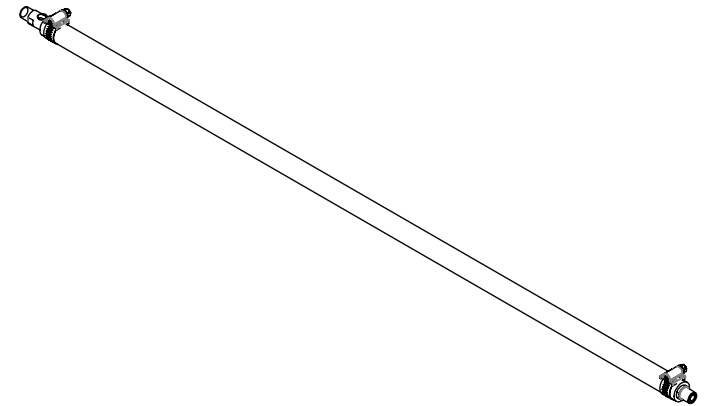
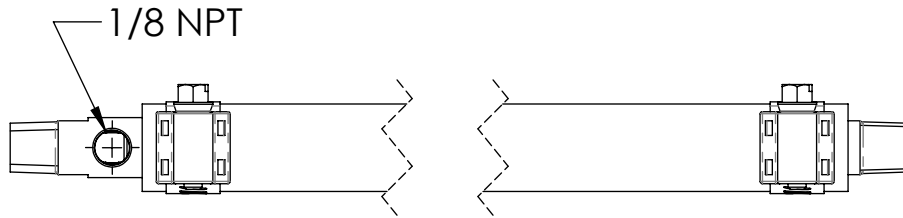

A

A

GENERAL NOTES:

1. "L" DIMENSION IS GIVEN IN METRIC UNIT "m"
2. CUSTOM LENGTH IS AVAILABLE

ALL INFORMATION CONTAINED IN THIS DOCUMENT IS PROPERTY OF SEEDORFF ACME CORP. AND MAY NOT BE REPRODUCED IN WHOLE OR PART WITHOUT PERMISSION OF SEEDORFF ACME CORP.

# SEEDORFF

RESISTANCE WELDING EQUIPMENT  
ANAHEIM, CA  
SEEDORFFACME.COM

2/0 WATER COOLED WELDING CABLE ASS'Y

PART NO.	SEE TABLE
DWG. NO.	R00033

2

1

**MODEL OPTIONS:**

**VOLTAGE**

- 220VAC Ø1
- 440VAC Ø1

**TRANSFORMER**

- 5 KVA
- 8 KVA

**HAND PIECES**

- POKE
- PINCH
- PINCH - POKE

**FRAME**

- SWIVEL-LEVELING FEET
- STATIONARY FEET

**WATER MANIFOLD**

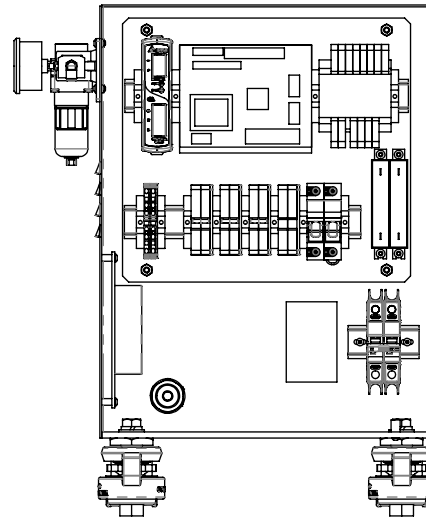
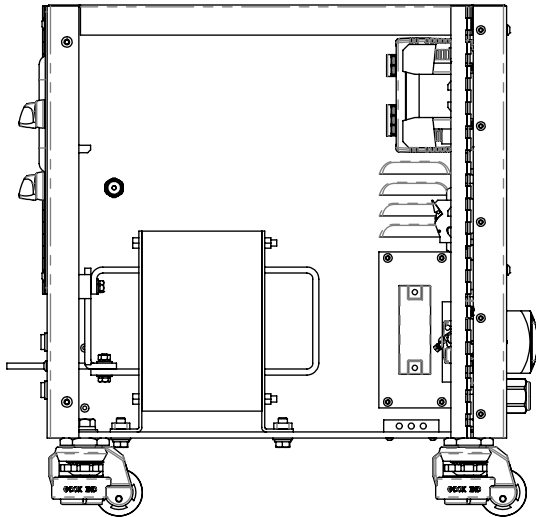
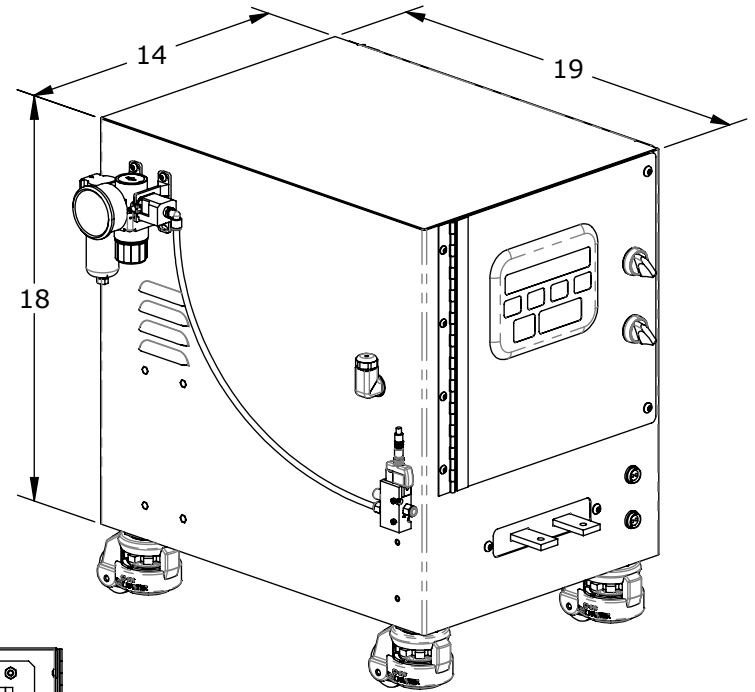

**SEEDORFF**

RESISTANCE WELDING EQUIPMENT  
ANAHEIM, CA  
SEEDORFFACME.COM

PORTABLE POWER SUPPLIES

PART NO. VARIES

DWG. NO. R00013

ALL INFORMATION CONTAINED IN THIS DOCUMENT IS PROPERTY OF SEEDORFF ACME CORP. AND MAY NOT BE REPRODUCED IN WHOLE OR PART WITHOUT PERMISSION OF SEEDORFF ACME CORP.



SHOP ONLINE

**RW**Electrodes.com

**Seedorff ACME Corporation**

1338 N Knollwood Cir,  
Anaheim, CA 92801

(714) 252-5330  
sales@seedorffacme.com

[seedorffacme.com](http://seedorffacme.com)