

INSTRUCTION MANUAL

- for the -

DT7306 TENS 7000™ RECHARGEABLE 4 CHANNEL



This manual is valid for the
TENS 7000 RECHARGEABLE 4 CHANNEL

This instruction manual is published by Compass Health Brands Corp.

Compass Health Brands Corp. reserves the right to improve and amend it at any time without prior notice. Amendments may however be published in new editions of this manual.

All Rights Reserved.Rev.V1.0 © 2023

FDA cleared for OTC use.

Conformity to safety standards

Compass Health Brands Corp. declares that the device complies with following normative documents:

**IEC60601-1, IEC60601-1-2, I EC60601-2-10,
ISO10993-5, ISO10993-10, ISO10993-1**

Table of Contents

1.	Introduction	4
	Indication for use	
2.	Important Safety Precautions and Warnings	4
3.	Package Contents	8
	3.1 Front And Rear Panel	
	3.2 LCD Display	
4.	Specifications	10
	4.1 Technical Information	
	4.2 Technical Specifications (TENS)	
	4.3 Technical Specifications (EMS)	
	4.4 Waveform Information (TENS)	
	4.5 Waveform Information (EMS)	
5.	Instructions For Use	12
	5.1 Battery	
	5.2 Using Your Device	
	5.3 To Set parameters	
	5.4 Check Compliance Meter	
	5.5 Check/Replace Batteries	
6.	Cleaning And Storage	17
	6.1 Keeping Electrodes Clean	
	6.2 Storing Device, Electrodes and Lead Wires	
7.	Troubleshooting	18
8.	Disposal	19
9.	Glossary Of Symbols	19
10.	Electromagnetic Compatibility (EMC) Tables	20
11.	Limited Warranty	23
12.	FCC COMPLIANCE STATEMENT	24

1. INTRODUCTION

Indication for Use:

TENS: The device is designed to be used for temporary relief of pain associated with sore and aching muscles in the shoulder, waist, back, neck, upper extremities(arm) and lower extremities (leg) due to strain from exercise or normal household work activities.

EMS: The device is designed to be used for stimulate healthy muscles in order to improve and facilitate muscle performance.

2. IMPORTANT SAFETY PRECAUTIONS AND WARNINGS

DANGER

This stimulator must **NOT** be used in combination with the following medical devices:

- Internally transplanted electronic medical devices, such as a pacemaker.
- Electronic life support equipment, such as respirators.
- Electronic medical devices attached to the body, such as electrocardiographs.



Using this stimulator with other electronic medical devices may cause erroneous operation of those devices.

WARNING

DO NOT USE THIS DEVICE UNDER THESE CONDITIONS

- Consult with your physician before using this device, because the device may cause lethal rhythm disturbances in certain susceptible individuals.
- If you have a cardiac pacemaker, implanted defibrillator, or other implanted metallic or electronic device. Such use could cause electric shock, burns, electrical interference, or death.
- Together with a life-supporting medical electronic device such as an artificial heart or lung or respirator.
- In the presence of electronic monitoring equipment (e.g., cardiac monitors, ECG alarms), which may not operate properly when the electrical stimulation device is in use.
- On open wounds or rashes, or over swollen, red, infected, or inflamed areas or skin eruptions (e.g., phlebitis, thrombophlebitis, varicose veins); or on top of, or in proximity to, cancerous lesions.
- Over areas of skin that lack normal sensation.
- On the opposite sides of your head since the effects of stimulation of the brain are unknown.

DO NOT USE ON THESE INDIVIDUALS

- Pregnant women.
- Children or infants.
- Persons incapable of expressing their thoughts or intentions.



WARNING (CONTINUED)

DO NOT USE THIS DEVICE DURING THESE ACTIVITIES

- When in the bath or shower.
- While sleeping.
- While driving, operating machinery, or during any activity in which electrical stimulation can put you at risk for injury.

PAIN MANAGEMENT WARNINGS

- If you have had medical or physical treatment for your pain, consult with your physician before using this device.
- If your pain does not improve, becomes seriously chronic or severe, or continues for more than five days, stop using the device and consult with your physician.
- The mere existence of pain functions as a very important warning telling us that something is wrong. Therefore, if you suffer from any serious illness, consult your physician in order to confirm that it is advisable for you to use this Electrical Stimulator.

WARNINGS AND PRECAUTIONS REGARDING THE ELECTRODES

- Apply electrodes to normal, healthy, dry, clean skin (of adult patients) because it may otherwise disrupt the healing process.
- If you experience any skin irritation or redness after a session, **DO NOT** continue stimulation in that area of the skin.

NEVER APPLY THE ELECTRODES TO :

- The head or any area of the face.
- Any area of the throat because this could cause severe muscle spasms resulting in closure of the airway, difficulty in breathing, or adverse effects on heart rhythm or blood pressure.
- Both sides of the thorax simultaneously (lateral or front and back), or across your chest because the introduction of electrical current may cause rhythm disturbances which could be lethal.



CAUTION

WARNINGS AND PRECAUTIONS REGARDING THE ELECTRODES

- **DO NOT** bend or fold because the pad may not function properly. Place the electrodes onto the plastic film and then store into the sealed package when not in use.

- **DO NOT** apply ointment or any solvent to the electrodes or to your skin because it will disrupt the electrodes from functioning properly.
- The electrodes are already pre-gelled and will adhere to your skin.
- To avoid damage to the adhesive surface of the electrodes, put the electrodes only on the skin or on the plastic film provided.
- Place the electrodes at least 2" apart but no more than 6" apart per channel.
- Make sure the components are connected well and the electrodes are fixed on the part of the body you wish to treat or the therapy may not be effective.

DO NOT USE YOUR ELECTRODES THIS WAY

- Electrodes should **NOT** touch each other when placed onto your skin.
- **DO NOT** place on your spine or backbone.
- Pad should **NOT** touch any metal object, such as a belt buckle or necklace.
- Electrodes should **NOT** be placed simultaneously on the soles of both feet.
- Electrodes should **NOT** be placed simultaneously on the calves of both legs.
- **DO NOT** share electrodes with another person. This may cause a skin irritation or infection. Electrodes are intended for use by one person.
- **DO NOT** place or relocate the electrodes while the device is on.
- **ALWAYS** turn the power off before removing or changing the pad location.
- **DO NOT** leave electrodes attached to the skin after treatment.

CAUTION WHILE USING THE STIMULATOR

- If the stimulator is not functioning properly or you feel discomfort, immediately stop using the device. If any type of shock or burn should occur, stop using immediately and consider seeking medical attention (if necessary).
- **DO NOT** use for any other purpose except for what it is intended for.
- **DO NOT** insert the electrode plug into any place other than the jack on the main device.
- **DO NOT** pull on the electrode cord during treatment.
- **DO NOT** use the device while wearing electronic devices such as watches as this may damage the device.
- **DO NOT** use near a cell phone as this may cause the stimulator to malfunction.
- **DO NOT** bend or pull the end of the cord.
- When pulling out the cord from the device, hold the plug and pull.
- Replace the cord when broken or damaged.
- **DO NOT** throw the batteries into a fire. The batteries may explode.
- Dispose of the device, batteries, and components according to applicable legal regulations. Unlawful disposal may cause environmental pollution.
- The size, shape and type of electrodes may affect the safety and effectiveness of electrical stimulation.
- The electrical performance characteristics of electrodes may affect the safety and effectiveness of electrical stimulation.
- Using electrodes that are too small or incorrectly applied, could result in discomfort or skin burns.

GENERAL PRECAUTIONS

- The patient is an intended operator of the device.
- The patient can fully operate the device, but maintenance and modification of the device can only be done by a service technician authorised by the manufacturer.
- The long-term effects of electrical stimulation are unknown.
- Apply stimulation to only normal, intact, clean, dry, and healthy skin.
- TENS is **NOT** effective in treating the original source or cause of the pain, including headache.
- TENS is **NOT** a substitute for pain medications and other pain management therapies.
- TENS devices **DO NOT** cure disease or injuries.
- TENS is a symptomatic treatment and, as such, suppresses the sensation of pain that would otherwise serve as a protective mechanism.
- Effectiveness is highly dependent upon patient selection by a practitioner qualified in the management of pain patients.
- If you have suspected or diagnosed heart disease, you should follow precautions recommended by your physician.
- If you have suspected or diagnosed epilepsy, you should follow precautions recommended by your physician.
- Use caution if you have a tendency to bleed internally, such as following an injury or fracture stop using the device. If any type of shock or burn should occur, stop using immediately and seek medical attention (if necessary).
- Consult with your physician prior to using the device after a recent surgical procedure, because stimulation may disrupt the healing process.
- Use caution if stimulation is applied over the menstruating or pregnant uterus.
- Use caution if stimulation is applied over areas of skin that lack normal sensation.
- **Keep device away from young children.** The device contains small pieces that may be swallowed. The electrode cord can cause strangulation. Immediately contact your physician should any of these things occur.
- Use this device only with the leads, electrodes, and accessories recommended by the manufacturer.
- **DO NOT** maintain or service the device while the device is in use.
- **DO NOT** modify this equipment without authorization of the manufacturer.
- The time required for the device to warm from the minimum storage temperature (-10°C) between use until the device is ready for use at ambient temperature (20°C) : about 2 hours.
- The time required for the device to cool from the maximum storage temperature (55°C) between use until the device is ready for use at ambient temperature (20 °C) : about 2 hours.

POSSIBLE ADVERSE REACTIONS

- **DO NOT** use to treat one region for extended periods of time (more than 30 minutes a session, up to 2 times/day) or muscles in that region may become exhausted and sore.
- You may experience skin irritation and burns beneath the stimulation electrodes applied to your skin.
- You should stop using the device and consult with your physician if you experience adverse reactions from the device.

NOTE: Always use electrodes that are legally marked and sold in the United States under 510K guidelines.

3. PACKAGE CONTENTS



TENS 7000 Rechargeable
4 CHANNEL device

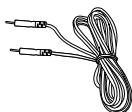

4 - Lead wires



8-2" x 2" Electrodes



Instruction Manual

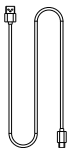

TYPE-C cable

REPLACEMENT PART NUMBERS

Item Number	Description	Qty
DT7306	TENS 7000 4 CHANNEL Device	1 each
WW3005	Lead wires 2/pk	2 per pack
DT7202-ELEC16	2" x 2" Electrodes	16 Electrodes
DT-USBC	TYPE-C cable	1 each

3.1 Front and Rear Panel

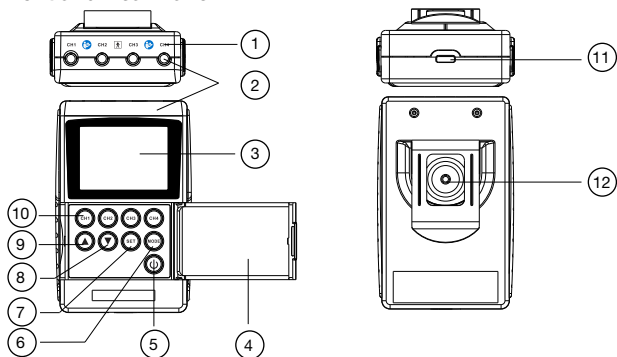

- | | |
|--------------------------|-----------------------|
| ① CH sign | ⑦ Set Control |
| ② Lead Connector | ⑧ Decrease Button |
| ③ Liquid Crystal Display | ⑨ Increase Button |
| ④ Panel Cover | ⑩ CH Selecting Button |
| ⑤ Power Control | ⑪ TYPE-C Connector |
| ⑥ Mode Control | ⑫ Belt Clip |

3.2 LCD Display

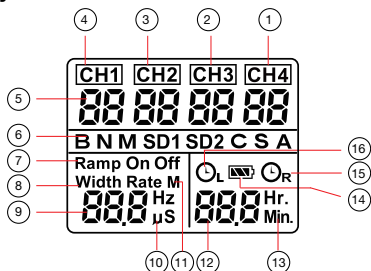

- | | |
|---------------------------------|----------------------------|
| ① CH4 sign | ⑨ Parameter number display |
| ② CH3 sign | ⑩ Hz/ μ s/s unit sign |
| ③ CH2 sign | ⑪ Compliance meter sign |
| ④ CH1 sign | ⑫ Treatment time display |
| ⑤ Output strength level display | ⑬ Hour/Min unit sign |
| ⑥ Active Mode Sign | ⑭ Low battery sign |
| ⑦ Ramp/On/Off settings sign | ⑮ Timer sign of CH1&CH2 |
| ⑧ Width/Rate settings sign | ⑯ Timer sign of CH3&CH4 |

4. SPECIFICATIONS

4.1 Technical Information

Channel	Four, isolated between channels
Li-ion Battery	3.7V --- 500mAh
Charging	5V --- 500mA at least
Operating Conditions	5°C – 40°C (41°F – 104°F) with a relative humidity of 30% – 75%, atmospheric pressure from 700 – 1,060 hPa
Storage and Transport Conditions	-10°C – 55°C (14°F – 131°F) with a relative humidity of 10% – 90%, atmospheric pressure from 700 – 1,060 hPa
Dimensions	10.1 × 6.1 × 2.45 cm (L*W*H)
Weight	0.26lb
Waveform	Asymmetrical Bi-Phasic Square Pulse
Pulse Amplitude	Adjustable, 0-80 mA at 500 ohm load each channel.
Pulse Width	Adjustable, from 50 to 300 microseconds, 10µs/step
Pulse Rate	Adjustable, from 2 to 150 Hz, 1 Hz/step
On Time	Adjustable, 2-90 seconds, 1Sec./step
Off Time	Adjustable, 0-90 seconds, 1Sec./step
Compliance Meter	This unit can store 60 sets of operation records. Total recorded time is 999 hours.
Standard Deviation (Remark)	There may be up to a +/-5% tolerance of all parameters and +/-20% tolerance of amplitude & voltage.
Service Life of the Device	3 years
Service Life of the Electrodes	Electrodes can be cleaned and reused for up to 10 -15 times
Service Life of the Battery	Fully charged battery will last for approx. 20 times (when used for 30 minutes a day, N mode, in half of the maximum intensity).
Applied Part	Electrode
Software version	V1
Classification of ME Equipment	Internally powered (operating) /Class II (charging) / Continuous

4.2 Technical Specifications (TENS)

Modes (5)	B (Burst), N (Normal), M (Modulation), SD1 (Strength Duration 1), SD2 (Strength Duration 2)
-----------	---

Burst Mode (B)	Burst Rate: Adjustable, 0.5 – 5Hz Pulse Width: Adjustable, 50 – 300µs Frequency: Fixed = 100 Hz
Normal Mode (N)	The Pulse Rate and Pulse Width are adjustable. It generates continuous stimulation based on the setting value.
Modulation Mode (M)	The Pulse Rate and the Pulse Width modulate automatically in a varied cycle pattern. The Pulse Width is decreased by 50% from its original setting in 0.5 seconds, then the Pulse Rate is decreased by 50% from its original setting in 0.5 seconds. Total cycle time is 1 second. In this mode, Pulse Rate and Pulse Width are fully adjustable.
SD1 Mode (SD1)	The intensity and Pulse Width automatically modulate within a 40% range. The intensity will increase by 40% in 5 seconds while the Pulse Width will decrease by 40% in the next 5 seconds and vice-versa. The total cycle time is 10 seconds. Pulse Rate and Pulse Width are fully adjustable.
SD2 Mode (SD2)	The intensity and Pulse Width automatically modulate within a 70% range. The intensity will increase by 70% in 5 seconds while the Pulse Width will decrease by 70% in the next 5 seconds and vice-versa. The total cycle time is 10 seconds. Pulse Rate and Pulse Width are fully adjustable.

4.3 Technical Specifications (EMS)

Modes (3)	C (Constant) , S (Synchronous) and A (Alternate)
Constant Mode(C)	The Pulse Rate, Pulse Width,Ramp time,and ON/OFF time are adjustable. It generates continuous stimulation based on the setting value, which is similar to the Normal Mode of TENS.
Synchronous Mode (S)	Stimulation of two channels occurs synchronously. The “ON” time includes “Ramp Up” and “Ramp Down” time. Therefore, the setting of “ON” time must be at least 2 x the value set for “Ramp” time. Ex: If “Ramp” set to 8 seconds, “ON” time must be at least 16 seconds.
Alternate Mode (A)	Stimulation of CH2 will occur after CH1 contraction is completed. The setting of the “ON” time must be at least 2 x the value set for the “Ramp” time and the “OFF” time must be at least equal to the “ON” time. Ex: If “Ramp” set to 8 seconds, “ON” and “OFF” time must be at least 16 seconds.

4.4 Waveform Information – TENS

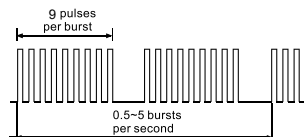

BURST

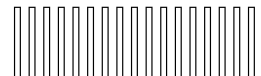

NORMAL

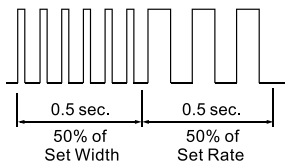

MODULATION

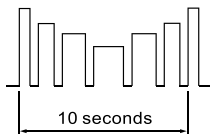

SD1 (STRENGTH DURATION)

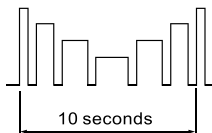

SD2 (STRENGTH-DURATION)

4.5 Waveform Information – EMS



SYNCHRONOUS (S)



ALTERNATE (A)

5. INSTRUCTIONS FOR USE

5.1 Battery

Battery charging

Insert the TYPE-C plug of the TYPE-C cable into the TYPE-C charging port of the device, and then connect to the Standard USB plug of the TYPE-C cable to the appropriate power supply device which can output 5V d.c., 500mA at least. When the battery indicator stop rolling and at full status, remove the TYPE-C plug from the TYPE-C socket of the device.

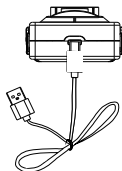

NOTES:

- When the battery indicator is going to be empty on the LCD, please charge the battery. If the battery power is too low, the device will turn off automatically.
- Only use the TYPE-C cable which is provided by the manufacturer. Device must be charged prior to first use. Typically, it takes about 2 hours to charge the device.
- Please charge the device fully before first use. If the charge is not complete at the first use, the battery may become depleted before the end of the session. You cannot use the device while it is charging.



WARNING

- If batteries leak and come into contact with the skin or eyes, wash immediately with copious amounts of water.
- The life of a rechargeable battery depends on the number of recharging/run-down cycles it undergoes and how these cycles are performed. The service life of rechargeable battery is more than 300 recharging/run-down cycles. We provide the following suggestions to extend the life of the battery.
- Whenever the device is not used frequently, we recommend recharging the battery once a month.

Disposal of Battery

Refer to Chapter 8.

5.2 Using Your Device

A. Panel Cover

A panel on the front of the device covers all the operating buttons.

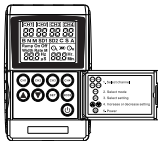

B. IMPORTANT SAFETY PRECAUTIONS AND WARNINGS

Before using the device for the first time, you are strongly advised to take careful note of the counter-indications and safety measures detailed at the beginning of this manual (Safety information), as this powerful equipment is neither a toy nor a gadget!
Refer to chapter 2.

C. Connect Lead Wires

- 1) Before proceeding to this step, be sure the device is completely turned OFF.
- 2) Insert the lead wires into the output sockets located on the top of the device.
- 3) Holding the insulated portion of the connector, push the plug end of the wire into one of the sockets (see fig.1); one or two or three or four of wires may be used.
- 4) This device has four output receptacles with corresponding channel (CH) button. The output strength level can be adjusted by using the Decrease Button and Increase Button.

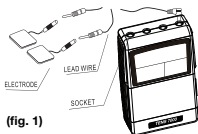

NOTE: If you use only one channel, only plug in 1 lead wire at the top of the unit

D. Turn on Device

Press the [] button to turn on the device.

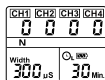

E. Select Waveform/Mode

To choose which waveform and mode to use, press  until the desired selection is displayed on the screen. There are 5 TENS Modes (B, N, M, SD1, SD2) and 3 EMS Modes (C, S and A) to choose from.



5.3 To Set parameters

A. Set Pulse Width



Press  button and the number for “Width” on the LCD screen will flash. To change the default number, press  or  until the desired Pulse Width number is displayed on the screen.

If the default Pulse Width is the desired number

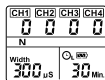
and no change is needed, press  to move on to the next parameter.



B. Set Pulse Rate

Press  and the number for “Rate” on the LCD screen will flash. To change the default number, press  or  until the desired Pulse Rate number is displayed on the screen.

If the default Pulse Rate is the desired number and no change is needed, press  to move on to the next parameter.

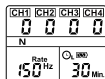

C. Set Ramp Up/Down Time for EMS

Press **SET** once and the number for “Ramp” on the LCD screen will flash. To change the number, press **▲** or **▼** until the desired ramp time is reached.

CH1	CH2	CH3	CH4
0	0	0	0
S			
Ramp		0.000	
3	s	30	Min

If the default Ramp time is the desired time and no change is needed, press **SET** to move on to the next parameter.

D. Set Contraction “ON” Time for EMS

Press **SET** and the number for “ON” on the LCD screen will flash. To change the number, press **▲** or **▼** until the desired contraction/”ON” time is reached.

CH1	CH2	CH3	CH4
0	0	0	0
S			
On		0.000	
3	s	30	Min

NOTE: The “ON” time must be 2 x times the “SET” number or higher. If the default “ON” time is the desired time and no change is needed, press **SET** to move on to the next parameter.

E. Set Relaxation “OFF” Time for EMS

Press **SET** button and the number for “OFF” on the LCD screen will flash. To change the number, press **▲** or **▼** until the desired relaxation/”OFF” time is reached.

CH1	CH2	CH3	CH4
0	0	0	0
S			
off		0.000	
3	s	30	Min

NOTE: For Alternate (A) Mode only, the OFF time must be at least equal to the “ON” time or higher.

If the default “OFF” time is the desired time and no change is needed, press **SET** to move on to the next parameter.

F. Set Timer

The treatment time is adjustable from 1 to 60 minutes or C (Continuous). Press **SET** control to enter this menu, then press **▲** or **▼** to adjust the setting. Press **▲** when the timer shows 60 minutes, it will be switched to continuous stimulation.

Note: \odot_L is the Timer sign of CH1&CH2.

\odot_R is the Timer sign of CH3&CH4.

The two timer can be set respectively.

CH1	CH2	CH3	CH4
0	0	0	0
N			
Rate		0.000	
150	Hz	30	Min

CH1	CH2	CH3	CH4
0	0	0	0
N			
Rate		0.000	
150	Hz	30	Min

Continuous

G. Connect & Place Electrodes

Once the parameters are set, connect electrodes before starting treatment. Take the electrodes out of the sealed package. Connect both pins of each lead wire to the pigtail of an electrode (one electrode will not work). Make sure the metal pin connector is not visible. Place electrodes on or around the treatment area, ensure electrodes are completely attached and at least 2" apart but no more than 6" apart per channel.



H. Start Treatment

After all parameters are set, select a channel by press corresponding channel(CH) selecting button, then, increase the output strength level by pressing Increase Button. Wait 2-3 seconds in between each increase to ensure the stimulation reaches a strong but comfortable stimulation.

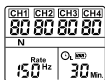

- NOTE:** 1) If the stimulation ever becomes uncomfortable, press the Decrease Button until a comfortable stimulation is reached.
2) Under C mode, only Width and Rate are adjustable.
3) Under EMS Mode, the display only prompt ON and OFF parameters are corresponding to the working status in real time.

WARNING

- 1) Should an emergency occur, press the power button and the device will completely power OFF and stop all stimulation.
- 2) **DO NOT** remove electrodes from treatment area until the device is turned off.

5.4 Check Compliance Meter

The compliance meter can store 60 sets of records with a total treatment time of 999 hours.

A. Check & Delete Individual Records

Press **MODE** button and turn on the power simultaneously. The LCD will show an "M" in the middle of the screen and will show the number records and the operation time. Press **▲** or **▼** to check each record. To delete a record, press **SET** button for 3 seconds.

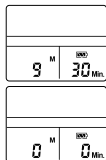

B. Check & Delete Accumulative Record

When in the individual records menu, press **MODE** to switch to accumulative records menu. To delete ALL records, press **SET** first, then the **MODE** button simultaneously for 3 seconds and ALL records will be deleted followed by a beeping sound.



5.5 Battery Charging

Over time, in order to ensure the functional safety and performance of the device, charging the battery is necessary

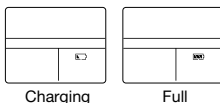

- Follow the chapter 5.1 to charge the battery.

6. CLEANING AND STORAGE

6.1 Keeping Electrodes Clean

- Ensure the device is completely turned off when removing the electrodes from the treatment area.
- Disconnect the electrodes from each lead wire and place on protective liner supplied with the electrodes.
- If electrodes are difficult to attach to the skin or the protective liner, they may be able to be reconstituted for one more use prior to replacing with new electrodes.
- Place a small drop of water on your cleaned fingertip and rub the water across the entire gel part. Place the electrode gel part, face up and let it air dry until the water is absorbed and reconstituted. This can only be done once and then the electrodes need to be replaced.
- **DO NOT** wipe with a tissue or cloth. If the electrodes are still not sticking completely to the treatment area without any lifting, they **MUST** be replaced with new electrodes.

CAUTION

1. The life of electrodes is dependent on many factors including, but not limited to, cleanliness of treatment area, oiliness of skin, amount of hair, increased sweating, storage state, etc.
2. If the electrodes are lifting or no longer stick to the treatment area, they **MUST** be replaced to avoid sudden shock or possible burns on any of the applied electrodes, including the electrodes adhered correctly and completely.
3. Before applying self-adhesive electrodes, it is recommended to wash the area with mild soap and water, completely drying the treatment area before placement.
4. **NEVER** remove the electrodes while the device is turned on.

 **CAUTION**

5. It is recommended to use the same size electrodes that are supplied with the device for replacement electrodes. Electrodes smaller than those provided may increase the chance of skin irritation or electrode burns. Electrodes larger than those provided may reduce the effect of stimulation, which could result in a false need to increase the intensity resulting in electrode burns or shocks.
6. If replacement electrodes are necessary, use only electrodes that are the same size (2" x 2") as the electrodes provided with the TENS 7000.

6.2 Storing Device, Electrodes and Lead Wires

- After electrodes have been removed from treatment site and disconnected from lead wires, place electrodes on the plastic liner and store in a resealable package.
- Wrap lead wires and store in a resealable package.
- Place the device, electrodes and lead wires back into the carrying case. Store in a cool, dry place ranging from 14°F – 131°F (-10°C – 55°C) with a relative humidity of 10% – 90%.
DO NOT keep in places that can be easily reached by children.

7. TROUBLESHOOTING

Problem	Possible Causes	Possible Solution
The unit cannot power on	The battery is exhausted.	Charge the device
Stimulation weak or cannot feel any stimulation	Electrodes are dried out or dirty.	Replace with new electrodes.
	Electrodes do not stick to skin well.	Replace with new electrodes.
	Lead wire is old, worn, or damaged.	Replace with new lead wire.
Stimulation is uncomfortable	Intensity is too high	Decrease intensity.
	Electrodes are too close together	Reposition electrodes to be at least 2 inches apart.
Intermittent output	The connection between lead wire and socket are poor.	Insert wire firmly.
	Lead wires are broken.	Replace with new lead wires.
Stimulation is ineffective.	Improper electrode placement.	Reposition electrode.
	Unknown	Contact clinician.

The skin becomes red and/or you feel a stabbing pain	Using the electrodes on the same site every time.	Reposition the electrodes. If at any time you feel pain or discomfort, stop use immediately.
	Electrodes are not adhered to the skin properly	Ensure the electrodes are securely adhered to the skin.
	The electrodes are dirty.	Clean the electrodes according to description in this manual or replace with new electrodes.
	The surface of the electrode is scratched.	
Output current stops during therapy	The electrodes come off the skin.	Turn off the device and place the electrodes on again, or replace with new electrodes.
	The lead wire is disconnected.	Turn off the device and connect the lead wire.
	The battery is exhausted.	Charge the device.

8. DISPOSAL

Used fully discharged batteries **MUST** be disposed of in a specially labeled collection container, at toxic waste collection points or through an electrical retailer. You are under legal obligation to dispose of batteries correctly.



Please dispose of the device in accordance with the legal obligation.



If you have any questions, Please contact the local authorities responsible for waste disposal.

9. GLOSSARY OF SYMBOLS



Disposal in accordance with Directive 2012/19/EU(WEEE)



Type BF Applied Part



Please refer to instruction manual.



Caution

10. ELECTROMAGNETIC COMPATIBILITY



(EMC) TABLES

- This device should not be used adjacent to or stacked with other equipment. If adjacent or stacked use is necessary, this device should be observed to verify normal operation in the configuration in which it will be used.
- Use of accessories other than those specified or provided by the manufacturer of this device could result in increased electromagnetic emissions or decreased electromagnetic immunity of this equipment and result in improper operation.
- Portable RF communications equipment (including peripherals such as antenna cables and external antennas) should be used no closer than 30 cm (12 inches) to any part of the device, including cables specified by the manufacturer. Otherwise, degradation of the performance of this equipment could result.
- When the operating environment is relatively dry, strong electromagnetic interference usually occurs. At this time, the device may be affected as follows:
 - the device stops output;
 - the device turns off;
 - the device restarts;
- The above phenomenon does not affect the basic safety and essential performance of the device, and the user can use it according to the instruction. If you want to avoid the above phenomenon, please use it according to the environment specified in the manual

TABLE 1		
declaration - electromagnetic emission		
The device is intended for use in the electromagnetic environment specified below. The customer or the user of device should assure that it is used in such an environment.		
Emissions test	Compliance	Electromagnetic environment - guidance.
RF emissions CISPR 11	Group 1	The device uses RF energy only for its internal function. Therefore, its RF emissions are very low and are not likely to cause any interference in nearby electronic equipment.
RF emissions CISPR 11	Class B	The device is suitable for use in all establishments, including domestic establishments and those directly connected to the public low-voltage power supply network that supplies buildings used for domestic purposes.
Harmonic emissions IEC 61000-3-2	Class A	
Voltage fluctuations/ flicker emissions IEC 61000-3-3	Complies	

TABLE 2			
declaration - electromagnetic immunity			
The device is intended for use in the electromagnetic environment specified below. The customer or the user of device should assure that it is used in such an environment.			
Immunity test	IEC 60601 test level	Compliance level	Electromagnetic environment - guidance
Electrostatic discharge (ESD) IEC 61000-4-2	±8 kV contact ±2 kV, ±4 kV, ±8 kV, ±15 kV air	±8 kV contact ±2 kV, ±4 kV, ±8 kV, ±15 kV air	Floors should be wood, concrete or ceramic tile. If floors are covered with synthetic material, the relative humidity should be at least 30 %.
Electrical fast transient/ burst IEC 61000-4-4	± 2 kV for power supply lines ± 1 kV for input/ output lines	± 2 kV for power supply lines ± 1 kV for input/output lines	Mains power quality should be that of a typical commercial or hospital environment.
Surge IEC 61000-4-5	± 0.5kV, ± 1 kV line(s) to lines ± 0.5kV, ± 1 kV, ± 2 kV line(s) to earth	± 0.5kV, ± 1 kV line(s) to lines ± 0.5kV, ± 1 kV, ± 2 kV line(s) to earth	Mains power quality should be that of a typical commercial or hospital environment.
Voltage dips, short interruptions and voltage variations on power supply input lines IEC 61000-4-11	0 % UT; 0.5 cycle At 0°, 45°, 90°, 135°, 180°, 225°, 270° and 315° 0 % UT; 1 cycle and 70 % UT; 25/30 cycles Single phase: at 0° 0 % UT; 250/300 cycles	0 % UT; 0.5 cycle At 0°, 45°, 90°, 135°, 180°, 225°, 270° and 315° 0 % UT; 1 cycle and 70 % UT; 25/30 cycles Single phase: at 0° 0 % UT; 250/300 cycles	Mains power quality should be that of a typical commercial or hospital environment. If the user of the device requires continued operation during power mains interruptions, it is recommended that the device be powered from an uninterruptible power supply or a battery.
Power frequency (50/60 Hz) magnetic field IEC 61000-4-8	30 A/m	30 A/m	Power frequency magnetic fields should be at levels characteristic of a typical location in a typical commercial or hospital environment.
NOTE: UT is the a.c. mains voltage prior to application of the test level.			

TABLE 3			
declaration - electromagnetic immunity			
The device is intended for use in the electromagnetic environment specified below. The customer or the user of device should assure that it is used in such an environment.			
Immunity test	IEC 60601 test level	Compliance level	Electromagnetic environment - guidance

<p>Conducted RF IEC 61000-4-6</p>	<p>3V 0.15 MHz to 80MHz 6 V in ISM and amateur radio bands between 0.15 MHz and 80 MHz</p>	<p>3 V 0.15 MHz to 80 MHz 6 V in ISM and amateur radio bands between 0.15 MHz and 80 MHz</p>	<p>Portable and mobile RF communications equipment should be used no closer to any part of device, than the recommended separation distance calculated from the equation applicable to the frequency of the transmitter. Recommended separation distance $d=1.2\sqrt{P}$ 150 KHz to 80 MHz $d=1.2\sqrt{P}$ 80 MHz to 800 MHz $d=2.3\sqrt{P}$ 80 MHz to 2.7 GHz Where P is the maximum output power rating of the transmitter in watts (W) according to the transmitter manufacturer and d is the recommended separation distance in meters (m).</p> <p>Field strengths from fixed RF transmitters, as determined by an electromagnetic site survey, a should be less than the compliance level in each frequency range.</p> <p>Interference may occur in the vicinity of equipment marked with the following symbol: </p>
<p>Radiated RF IEC 61000-4-3</p>	<p>10 V/m 80 MHz to 2.7 GHz</p>	<p>10V/m</p>	<p>80 MHz to 800 MHz $d=2.3\sqrt{P}$ 80 MHz to 2.7 GHz Where P is the maximum output power rating of the transmitter in watts (W) according to the transmitter manufacturer and d is the recommended separation distance in meters (m).</p> <p>Field strengths from fixed RF transmitters, as determined by an electromagnetic site survey, a should be less than the compliance level in each frequency range.</p> <p>Interference may occur in the vicinity of equipment marked with the following symbol: </p>

NOTE 1: At 80 MHz and 800 MHz, the higher frequency range applies.

NOTE 2: These guidelines may not apply in all situations. Electromagnetic propagation is affected by absorption and reflection from structures, objects and people.

- a Field strengths from fixed RF transmitters, such as base stations for radio (cellular/cordless) telephones and land mobile radios, amateur radio, AM and FM radio broadcast and TV broadcast cannot be predicted theoretically with accuracy. To assess the electromagnetic environment due to fixed RF transmitters, an electromagnetic site survey should be considered. If the measured field strength in the location in which device is used exceeds the applicable RF compliance level above, device should be observed to verify normal operation. If abnormal performance is observed, additional measures may be necessary, such as reorienting or relocating device.
- b Over the frequency range 0.15 MHz to 80 MHz, field strengths should be less than 3 V/m.

TABLE 4

Recommended separation distances between portable and mobile RF communications equipment and device

The device is intended for use in an electromagnetic environment in which radiated RF disturbances are controlled. The customer or the user of device can help prevent electromagnetic interference by maintaining a minimum distance between portable and mobile RF communications equipment (transmitters) and device, as recommended below, according to the maximum output power of the communications equipment.

Rated maximum output power of transmitter W	Separation distance according to frequency of transmitter m		
	0.15 MHz to 80 MHz $d=1.2\sqrt{P}$	80 MHz to 800 MHz $d=1.2\sqrt{P}$	80 MHz to 2.7 GHz $d=2.3\sqrt{P}$
0.01	0.12	0.12	0.23
0.1	0.38	0.38	0.73
1	1.2	1.2	2.3
10	3.8	3.8	7.3
100	12	12	23

For transmitters rated at a maximum output power not listed above, the recommended separation distance d in meters (m) can be estimated using the equation applicable to the frequency of the transmitter, where P is the maximum output power rating of the transmitter in watts (W) according to the transmitter manufacturer

NOTE 1: At 80 MHz and 800 MHz, the higher frequency range applies.

NOTE 2: These guidelines may not apply in all situations. Electromagnetic propagation is affected by absorption and reflection from structures, objects and people.

11. LIMITED WARRANTY

All TENS 7000 models carry a limited warranty of one year from the date of delivery. The limited warranty applies to the stimulator only and covers both parts and labor relating thereto. The limited warranty does not apply to damage resulting from failure to follow the operating instructions, accidents, abuse, alteration or disassembly by unauthorized personnel.

- 1) The limited warranty period for device is one year from date of purchase. In case of a limited warranty claim, the date of purchase has to be proven by means of the sales receipt or invoice.
- 2) Repairs or replacement under warranty DO NOT extend the warranty period either for the device or for the replacement parts.
- 3) The following is excluded under the limited warranty:
 - All damage which has arisen due to improper treatment, e.g. nonobservance of the user instruction.
 - All damage which is due to repairs or tampering by the customer or unauthorized third parties.
 - Damage which has arisen during transport from the manufacturer to the consumer or during transport to the service center.
 - Accessories included with the device.
- 4) Liability for direct or indirect consequential losses caused by the device is excluded even if the damage to the device is accepted as a limited warranty claim.

12. FCC COMPLIANCE STATEMENT

FCC Supplier's Declaration of Conformity

Product Name: TENS 7000 4 CHANNEL

Model Number: DT7306

Responsible Party

Company Name: Compass Health Brands Corp.

Address: 6753 Engle Rd Middleburg Heights, OH 44130

Phone Number: 800.871.7858

This device complies with part 15 of the FCC Rules. Operation is subject to the following two conditions:

- (1) This device may not cause harmful interference, and
- (2) This device must accept any interference received, including interference that may cause undesired operation.

Note: This equipment has been tested and found to comply with the limits for a Class B digital device, pursuant to part 15 of the FCC Rules. These limits are designed to provide reasonable protection against harmful interference in a residential installation. This equipment generates, uses and can radiate radio frequency energy and, if not installed and used in accordance with the instructions, may cause harmful interference to radio communications. However, there is no guarantee that interference will not occur in a particular installation. If this equipment does cause harmful interference to radio or television reception, which can be determined by turning the equipment off and on, the user is encouraged to try to correct the interference by one or more of the following measures:

- Reorient or relocate the receiving antenna.
- Increase the separation between the equipment and receiver.
- Connect the equipment into an outlet on a circuit different from that to which the receiver is connected.
- Consult the dealer or an experienced radio/TV technician for help.



Manufactured for:
Compass Health Brands Corp.
6753 Engle Rd
Middleburg Heights, OH 44130
www.compasshealthbrands.com
800.871.7858
Made in China ©2023