



## upTOP ALPHA 2-3G Tacoma 2005-2023 DC

**Effective 2023 we are making some changes to our products that might not be reflected in this guide. Major changes for 2023 include:**

- Removal of **lock washers** from hardware kits in some cases.
- Switching to through-bolt assembly on Alpha roof racks instead of rivet nuts.
- Foot to rack bolts upgraded to lock nuts.
- Revised slot array in grooveTEK on Alpha/Bravo roof racks.

Thank you for selecting upTOP™ as the choice for your vehicle. The Alpha roof rack designed for your platform requires competency with basic hand tools and assembly procedures. If you are not comfortable or you feel it is above your pay grade you are encouraged to seek professional installation of this product.

### **TOOLS REQUIRED**

- 5/32 Allen wrench
- 5mm Allen wrench
- 13mm wrench
- 1/2" wrench (2X)
- 7/16" wrench
- Silicone Sealant
- VibraTITE VC-3 Threadlocker (Included)

***The dynamic (moving) weight capacity of your roof rack far exceeds the specifications set forth by Toyota. Please follow manufacturer recommendations for the safe roof load capacity for the Toyota Tacoma. upTOP recommends keeping evenly distributed cargo loads of 175 pounds on the Toyota Tacoma. Static (parked) weight restrictions are limited to 550 pounds.***

You will need adequate floor space to assemble your roof rack prior to installing it to your vehicle. An area 80x80" is recommended for this assembly.

You are encouraged to inspect the contents of your package prior to completing assembly and installation. For any missing/damaged parts email pictures and descriptions to [support@uptopoverland.com](mailto:support@uptopoverland.com) with your order number as reference in the subject line. A specialist will assist you with the process for field repair or component replacement.

***It is important to plan for any wiring that needs to be completed during the course of rack installation. Incorporate these steps into the steps in this guide at points that reduce additional disassembly of the rack while it is installed on the vehicle.***

## Component Parts List

Figure 1 Master Component List *2/3G Tacoma Alpha*

Part Number	Quantity	Description
1069.2	1	Driver Side grooveTEK
1070.2	1	Passenger Side grooveTEK
1167	1	Driver Side Armor
1168	1	Passenger Side Armor
1305	2	Front Foot-Steel/Ambi
1307	2	Rear Foot-Steel/Ambi
LB50	7* SEE NOTE	Load Bar-50"
12XX	1	Front Fairing
8001	1	Master Hardware Kit

*This chart is the master component list for the 2/3G Tacoma Alpha Roof Rack. These numbers will be referenced throughout this guide.*

*Orders placed requesting freshAIR kits ship with six (6) 50" bars instead of seven (7).*

*The front fairing part identification is specific to each light bar configuration and numbers will vary. Fairings cut for light bars MIGHT include hardware required for mating that light bar to your upTOP fairing. The parts for this task ARE NOT included in the master component list. See the rear of this guide for lighting specific applications.*

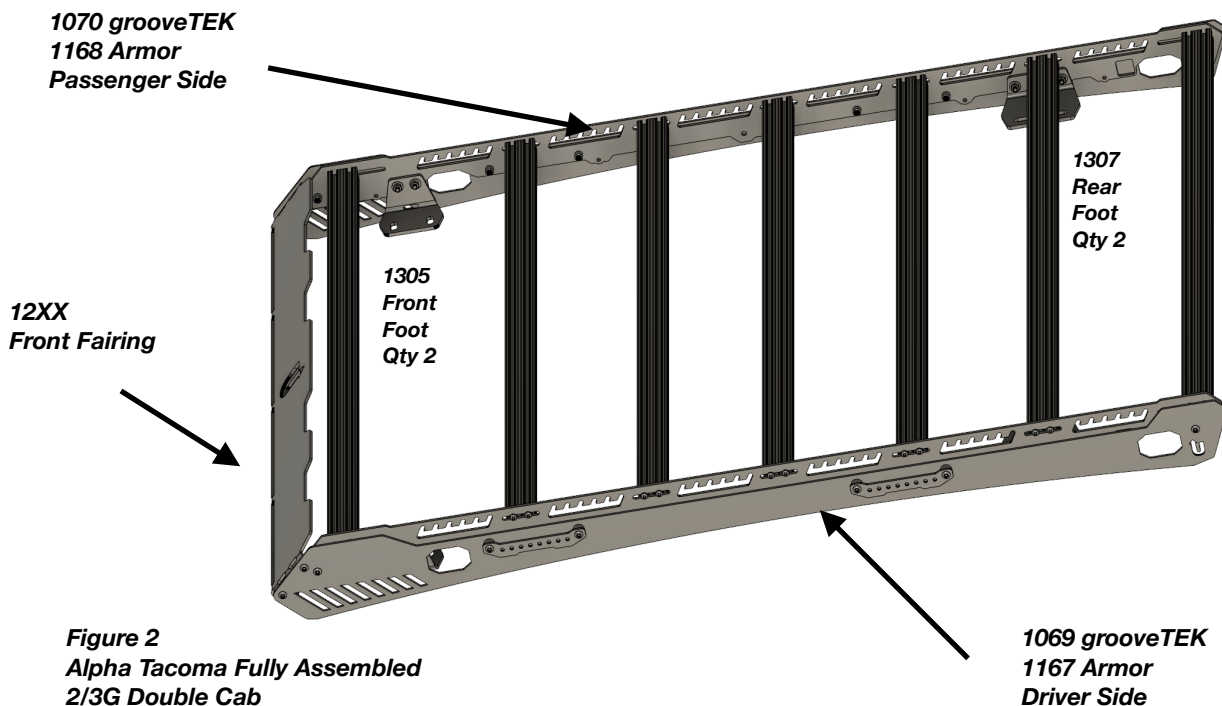

Figure 2  
Alpha Tacoma Fully Assembled  
2/3G Double Cab  
Driver Side Prominent Front of rack at left of image

## STEP I Feet to Rack

The feet included with your kit were designed specifically for your vehicle and rack assembly. Each foot will attach to the rack at two locations to distribute the weight load of the rack and ensure structural integrity. This design incorporates steel feet that have gone through a complex finishing process to resist corrosion over the life of your rack.

You have specific feet for the front and rear locations on your vehicle in this kit. The feet are mirrored by design so there is NO LEFT or RIGHT orientation to worry about.

We will start the assembly with the feet for the driver side of the rack. These steps and drawings will outline that process in depth and when completed simply repeat the steps with the feet on the passenger side until all four (4) feet are installed.

### GATHER THE FOLLOWING

- 1069 Driver Side grooveTEK
- 1070 Passenger Side grooveTEK
- 1305 Front Feet (Quantity 2) *Figure 3*
- 1307 Rear Feet (Quantity 2) *Figure 4*
- Hardware Kit labeled "Feet to Rack"
- 1/2" wrench (2X)
- VC3 thread compound

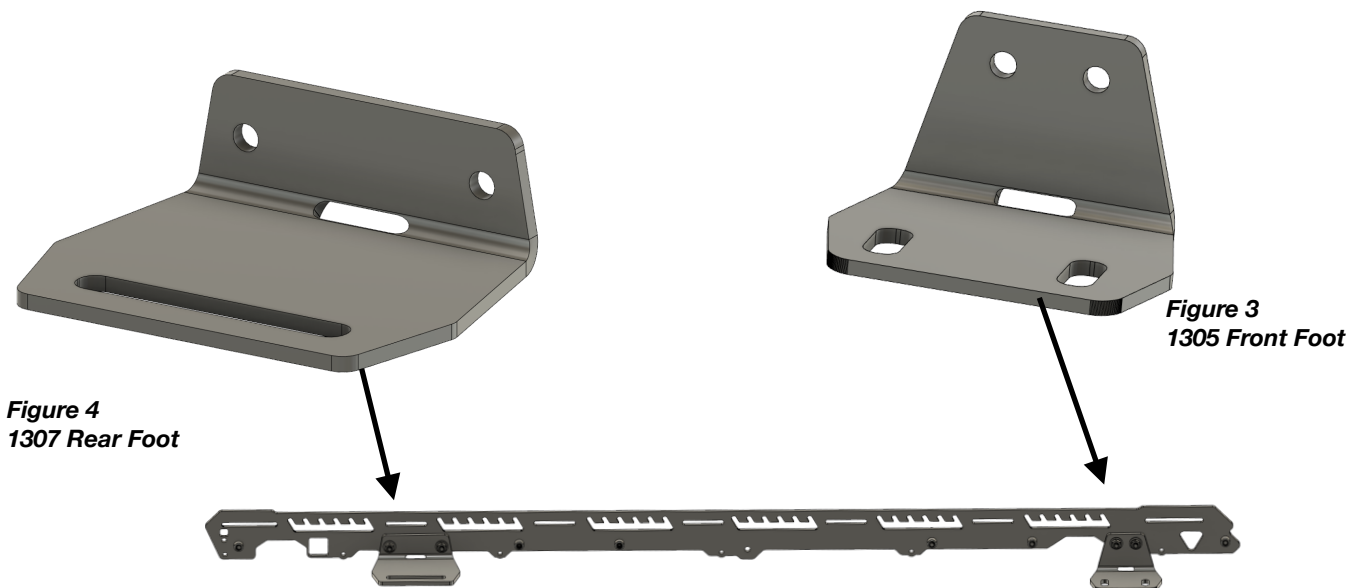
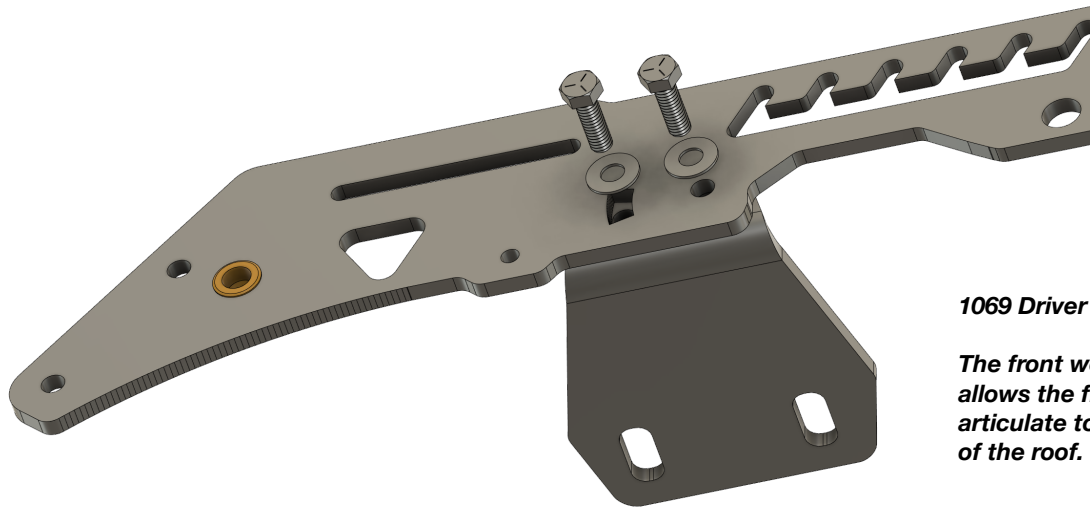

**Figure 4**  
1307 Rear Foot

**Figure 3**  
1305 Front Foot

**Figure 5**  
Driver Side (1069) Shown from inside rack assembly

**STEP I (CONT)**  
**Feet to Rack**



**1069 Driver Side Shown**

**The front wedge shape allows the front foot to articulate to match the curve of the roof.**

**Figure 6**  
**Driver Front Foot (1305) shown mated to 1009.2.**

**Apply VC3 Thread locking compound to the threads of all eight (8) feet to rack bolts and allow to dry. 15-20 minutes. Compound will remain gummy.**

- Slip hardware through the the holes (one of these holes is wedge shaped) in the driver side plate and install the 1305 foot over the studs. Install the provided flat washers, lock washers, and nuts. Leave the hardware loose so that the feet can be final adjusted to the roof curvature during final installation.
- REPEAT THE PROCESS for the remaining 1305 and mate it to 1010.2 Passenger grooveTEK.
- Final torque specification is **130 inch pounds**.

**Figure 7**  
**Driver Rear Foot (1307) shown mated to 1069.**

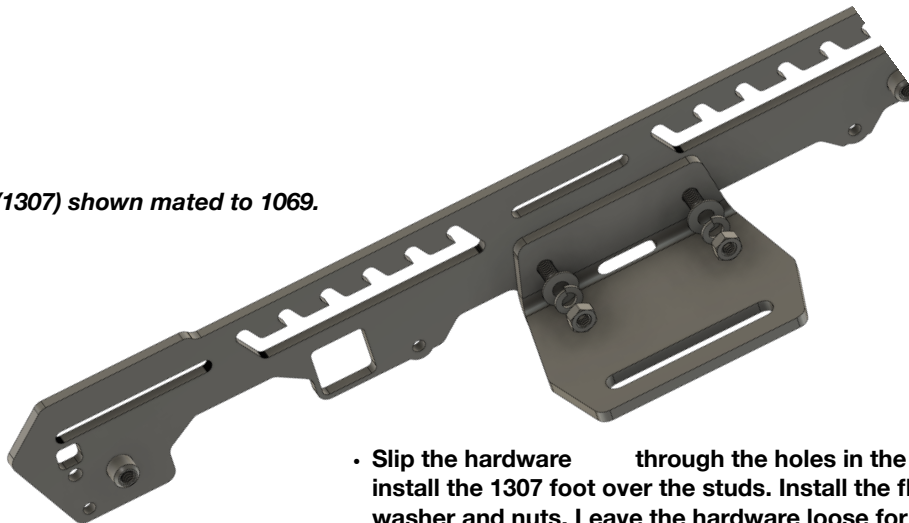

- Slip the hardware through the holes in the driver side plate and install the 1307 foot over the studs. Install the flat washers, lock washer and nuts. Leave the hardware loose for adjustment during final installation.
- REPEAT THE PROCESS for the remaining 1307 and mate it to the 1010.2 Passenger grooveTEK. **130 inch pounds**

## Step 2 Load Bars

### GATHER THE FOLLOWING:

- LB50 Load Bars (Quantity 7)
- 5/32 Allen wrench
- 7/16" wrench
- Hardware kit labeled "Load Bars"

The included 50" load bars run from driver to passenger side and feature hardware grooves on all sides allowing for gear attachment points. Two different types of hardware are required for this step. The **HEX nuts are for the front and rear load bar**. We use these so that the load bars can be adjusted with a wrench after the armor is installed.

The rear load bar can be flipped (vertically or horizontally) allowing the factory antenna to be retained on the truck without the need for additional modifications to the vehicle. If your vehicle doesn't have a shark fin style antenna on the roof you can run the rear load bar in any orientation. If equipped with a shark fin antenna it is recommended that you run the rear load bar vertically.

The following drawings show the difference between vertical and horizontal for the **REAR** load bar.

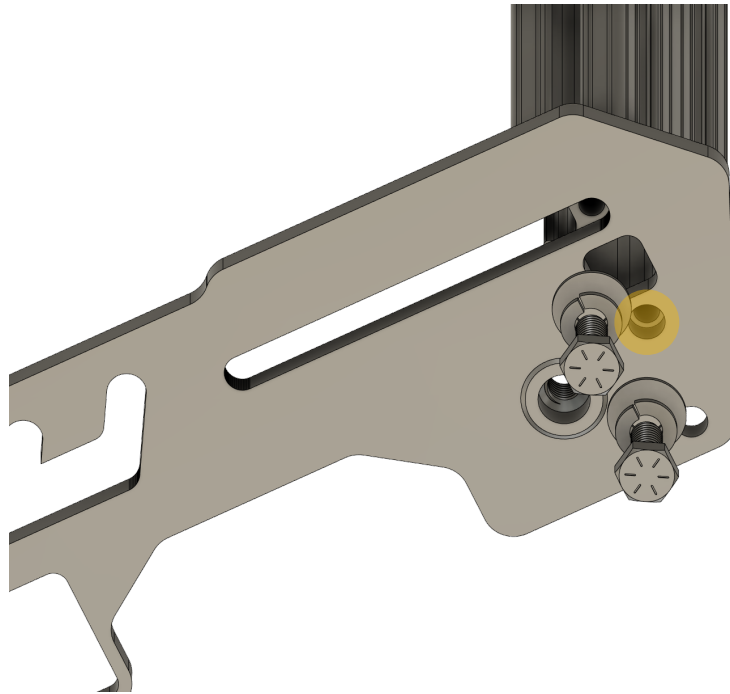

**Figure 8**  
**1069 Driver Side Shown**  
**Rear Load Bar in VERTICAL orientation.**

For this orientation use rear of the last slot in the grooveTEK and the hole highlighted in orange (**Figure 8**). The square hole in between is for passing wiring through the hollow portion of the load bar to each the passenger side of the vehicle. Install the hardware to connect the drivers side (1009.2) and passenger side (1010.2).

**STEP 2 (CONT)**  
**Load Bars**

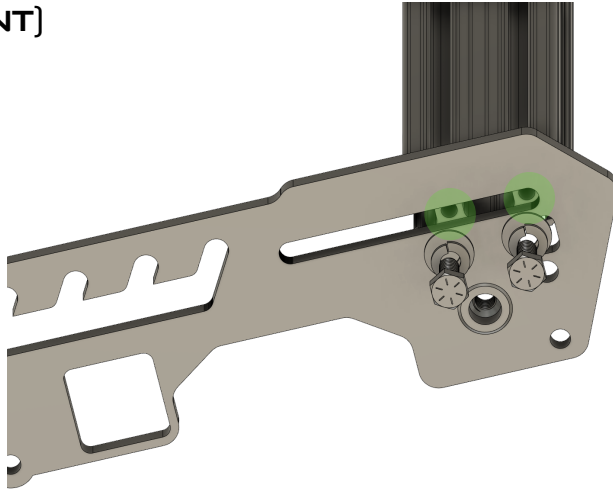

**Figure 9**  
**1069 Driver Side Shown**  
**Rear Load Bar in HORIZONTAL orientation.**

The two holes highlighted in **GREEN** indicate the mounting location for the rear load bar horizontally in the rack assembly. This is the recommended orientation for vehicles that **DO NOT** feature a factory installed shark fin antenna for the rear load bar. In this orientation the wires will pass through the slot and load bars to the passenger side of the vehicle.

Install the hardware to connect the drivers side (1069) and passenger side (1070) to the rear load bars.

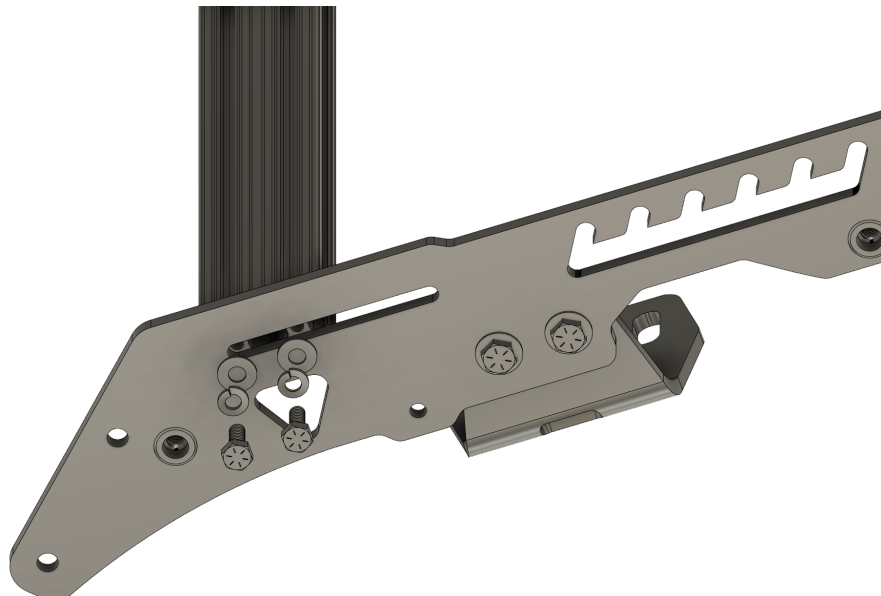

**Figure 10**  
**1069 Driver Side Shown**  
**Front Load Bar**

- Using the provided HEX head bolts, lock washers, and flat washers install the load bars into the slot at the front of the grooveTEK.
- **REPEAT THE PROCESS** for attaching the passenger side grooveTEK to the front load bar.

## STEP 2 (CONT) Load Bars

When the rack is installed on your vehicle it changes the aerodynamic signature of the vehicle. A roof rack loaded with gear will amplify this exponentially depending on the size of the components that are loaded onto the rack.

***In situations where the rack will run unloaded (nothing on it) it is important to install the FRONT load bar in the forward most position inside the slot. This reduces wind drag over the load bar that can cause vibration at 40-50mph resulting in transfer noise that wouldn't normally be noticeable with a roof rack loaded with gear.***

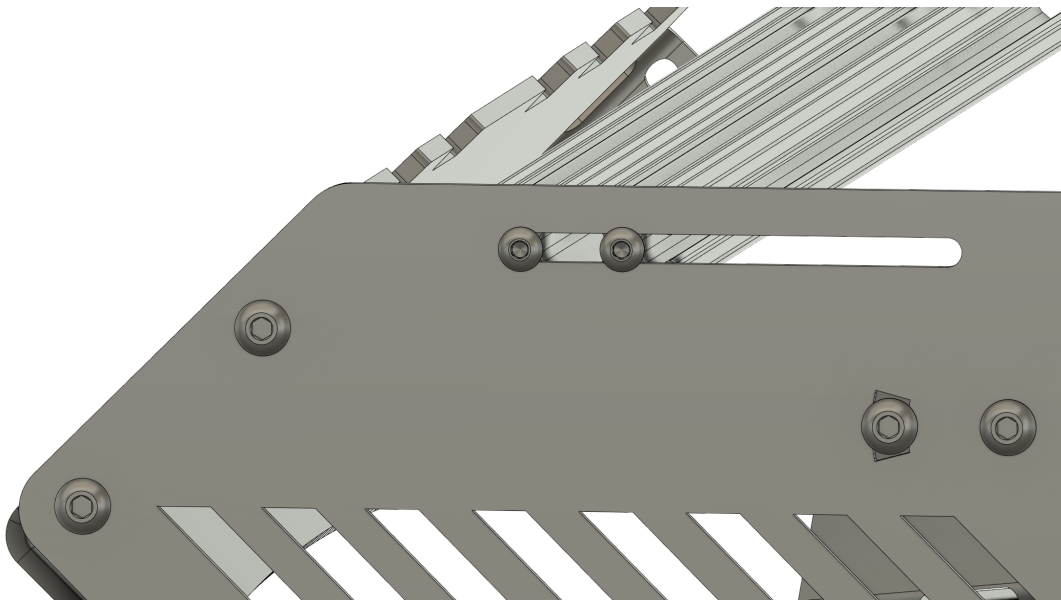

**Figure 11**  
**Fully Seated Front Load Bar**  
**Driver Side (Bravo) shown.**

Run the front load bar in this position when the rack is unloaded (empty).

### TORQUE SPECIFICATION

After installation is completed and the load bars are positioned to your preference torque the hex bolts for the

#### **NOTE!!**

*Fairings cut for specific light bars as well as universal 40 cuts will experience significant wind noise when installed into the rack assembly and driven at speed with the light bar absent from the assembly. Wind passes through the open holes and/or slot and is intercepted by the front slot on the load bars.*

*The fairings are designed with this in mind and the angles/openings are engineered to work in unison with the light bars to limit or eliminate noise/vibration.*

## Step 2 (CONT) Remaining Load Bars

The remaining load bars use 1/4-20x1 button head bolts and lock washers.

Using the 5/32" Allen wrench and the remaining hardware install the other five (5) load bars into the rack and tighten them. **SNUG IS GOOD FOR NOW. DO NOT OVER TIGHTEN.** The lock washers will bite when fully tightened and this could damage the finish of the powder coat on your rack if you want to adjust the load bars after the rack is on the vehicle.

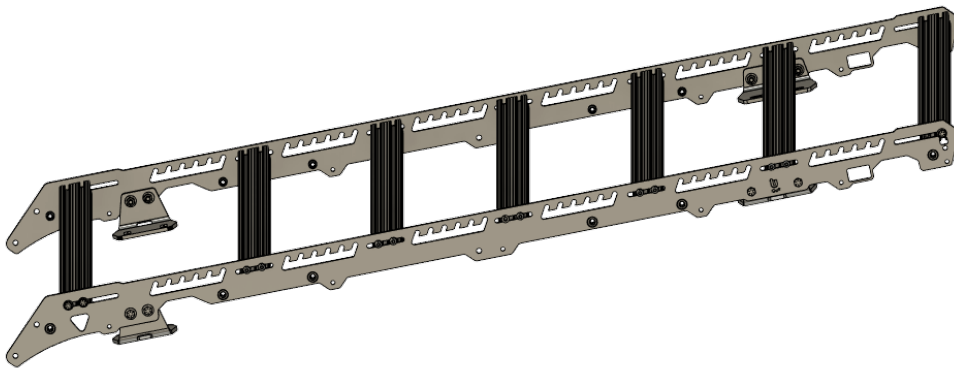

**Figure 12**  
**1069 Driver Side Shown Prominent**  
**1070 Passenger side in back ground.**

- Install the remaining five (5) load bars into the rack. Leave the load bars slightly loose until final installation is completed.
- REPEAT THE PROCESS on the passenger side(1070).

Final load bar torque specification for the button head bolts: **70 inch** pounds.

The slots in the load bars allow adjustability to line up and mount various pieces of gear that might not have enough adjustability built into them.

Aside from the front load bar position outlined in **FIGURE 11** the final installed position of the load bars in the roof rack is not relevant The rack design is capable of maintaining structural integrity with up to two (2) of the load bars removed at any time as long as they are not neighbors. This is to allow easier mounting of larger gear and roof top tents.



## STEP 3 Fairing Installation

The fairing for your roof rack utilizes a splitter design that cuts through the air at speed and splits the wind. This patent pending design is the result of hundreds of hours of design, engineering and testing. The end result is a design that cuts through the air forcing air under the rack taking advantage of the aerodynamic signature of your vehicle as well as pushing air up and over the rack giving the roof rack a smaller aerodynamic profile that results in the least amount of wind noise possible with an aftermarket roof rack. The large upper face serves to cut air up and over any gear that you might have attached to it.

***If your fairing is cut for lighting you are encouraged to install the light bar(s) prior to installing the roof rack on the vehicle. This will add some weight during the process of lifting the roof rack onto the vehicle but it is far easier to install the light bars into the fairing whilst it is off the vehicle and at a good working height. The rear of this guide contains information on mating a light bar to your fairing.***

**Gather the following:**

- Fairing specified in your order\*
- Hardware kit labeled "Fairing"
- 5mm Allen wrench
- 13mm wrench

***Apply VC3 Thread locking compound to the threads of all eight (8) feet to rack bolts and allow to dry. 15-20 minutes. Compound will remain gummy.***

***\*If your fairing is cut for a specific light bar you will also been delivered a kit of hardware for that task that is NOT listed in the parts for this step. Refer to rear of guide for lighting installation.***



**Figure 17**  
**Fairing Installation**  
**1069 Driver Side Shown**

***The fairing mourning tabs go to the INSIDE of the grooveTEK parts.***

- **Align the holes on the rack side to the holes on the tab of your fairing.**
- **Slip the hardware through both sets of holes.**
- **REPEAT THE PROCESS on the passenger side.**

### STEP 3 (CONT) Fairing Installation

The supplied flange nuts install onto the threads of the fairing attachment bolts. Reach inside the rack assembly and start each flange nut by hand. With all four (4) flange nuts started use a 5mm Allen wrench and 13mm open end wrench and tighten the fasteners to **130 inch pounds**.

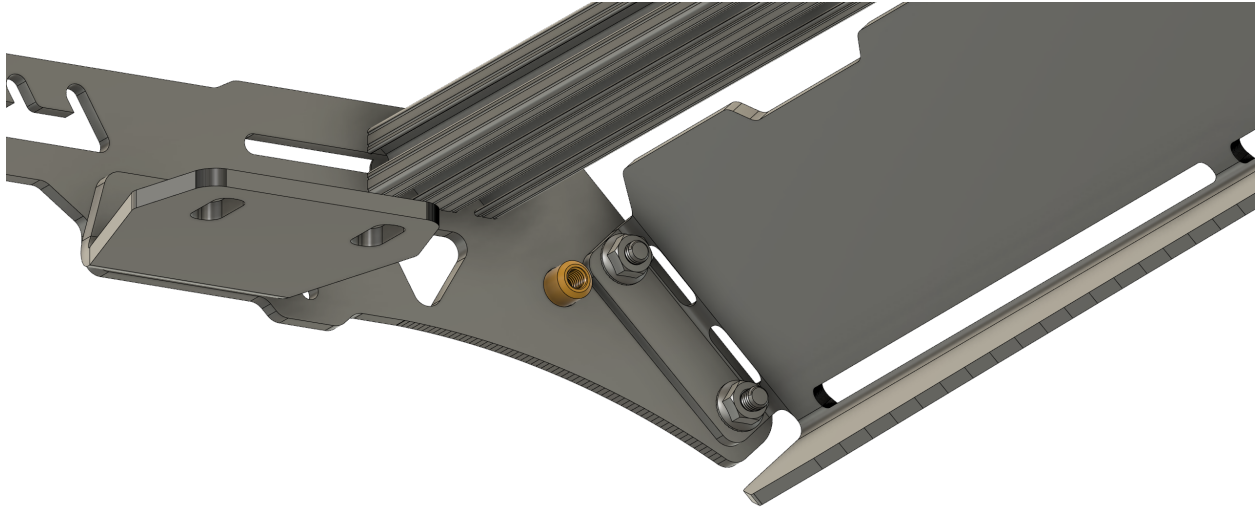

**Figure 13**  
**Fairing Installation Inner Hardware**  
**1069 Driver Side Shown**

- Install a flange nut onto each of the four (4) fairing bolts.
- Using a 5mm Allen wrench and 13mm open end wrench tighten the hardware assemblies to **130 inch pounds**.
- Repeat the process on the passenger side.

#### **WARNING**

*Fairings cut for specific light bars as well as universal 40 cuts will experience significant wind noise when installed into the rack assembly and driven at speed with the light bar absent from the assembly. Wind passes through the open holes and/or slot and is intercepted by the front slot on the load bars.*

*The fairings are designed with this in mind and the angles/openings are engineered to work in unison with the light bars to limit or eliminate noise/vibration.*

## STEP 4 Grab Handle Tying

### TOOLS REQUIRED:

- Needle Nose Pliers
- Lighter
- Crimp Tool
- Side Cutting Pliers

As the grab handles are installed to the rack as a completed assembly the next step is to tie and complete the safety wire installation for the grab handles of your rack. The installation of the armor to your roof rack requires the grab handle lace plate as part of the final attachment.

The grab handles and their required components are packaged by themselves. Locate the bag and proceed with tying the handles.

[Our process for handle tying is outlined in a video on our website under the instructions tab and linked below.](#)

Feel free to follow our method or get creative with your paracord knots and go your own route. The kits are shipped with standard black 550 paracord but you can order any color that you like from paracord planet or other online sources.

The included safety wire and crimp replacements are available on our website or by calling our technical support Monday-Friday from 8am-4pm MST.

Once you've tied all included handles you can proceed to step 4: Armor attachment.



upTOP 2-3G Tacoma Alpha

## STEP 5 Armor to grooveTEK

Figure 13  
Alpha 2/3G Tacoma  
Driver Side Shown

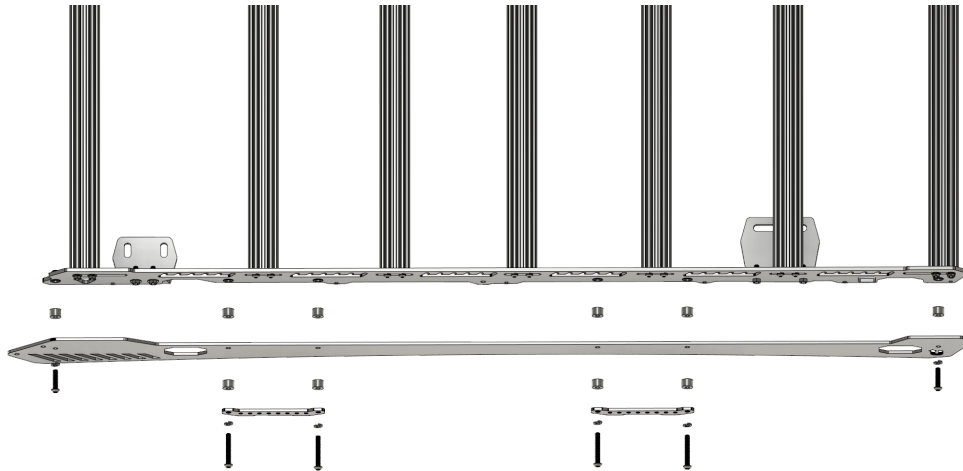

### GATHER THE FOLLOWING

- 1167 Driver Side Armor
- 1168 Passenger Side Armor
- Handle assemblies completed in step 3
- Hardware Kit Grab Handles
- 5mm Allen wrench

### NOTE

*If you are installing our quickWIRE™ (optional) or other wiring (not included) into the rack assembly you are strongly encouraged to complete those tasks before proceeding. Instructions are available on our website under the instructions tab.*

*If you are installing our scenePOD™ (optional) products into your rack you are strongly encouraged to trim the tabs on the scenePOD knockouts prior to installing the armor to the grooveTEK. Instructions for this task are available on our website under the instructions tab.*

The hardware kit includes two (2) different length bolts:

- 35mm (used for front and rear attachment points)
- 55mm (used for grab handle attachment points)

The spacers and lock washers are of common size and will be used throughout the process.

The spacers provide a space in between the armor and grooveTEK to allow wiring to pass and remain protected on the trail. There are machined attachment points for completing this task outlined in the quickWIRE installation guide.

## STEP 5 (CONT) Armor to grooveTEK

**Figure 14**  
**1069 Mating to 1167 Shown**  
**Driver Front**

- 35mm Bolt
- 8mm Lock Washer
- Plastic Spacer

The two holes highlighted in **ORANGE** will not be present on current production parts and your wind screen will attach directly to your grooveTEK, not your armor.

- Using a 5mm Allen wrench slide the bolt through the lock washer. Push that assembly through the armor.
- Place a spacer over the threads and thread the bolt into the insert (shown here in green.)
- Repeat the process with the passenger side armor (1110).

Torque Spec: **100 Inch Pounds**

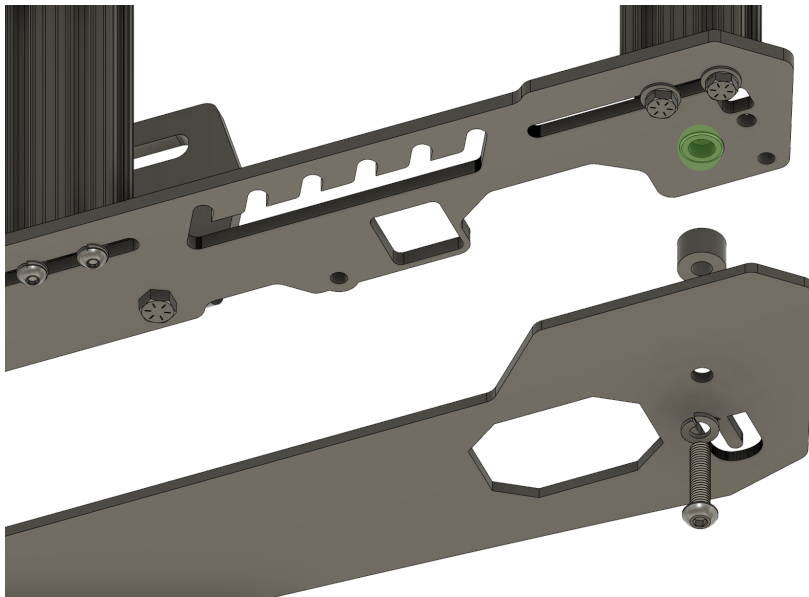
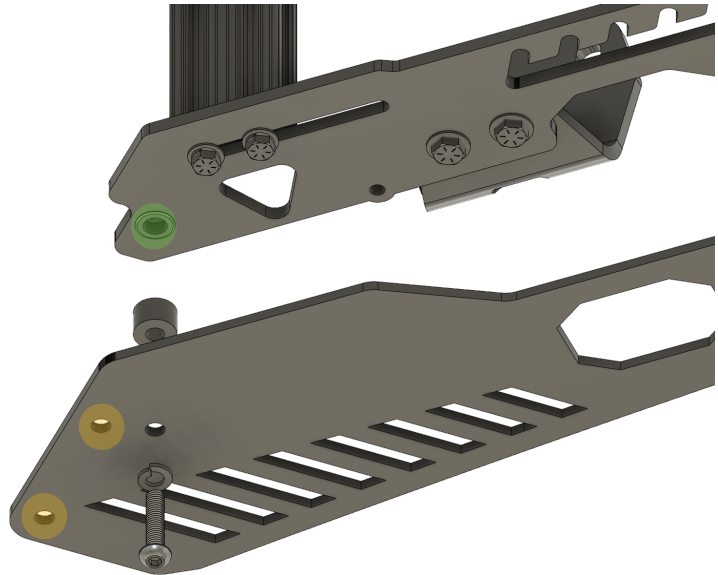

**Figure 15**  
**1069 Mating to 1167 Shown**  
**Driver REAR**

- 35mm Bolt
- 8mm Lock Washer
- Plastic Spacer

- Using a 5mm Allen wrench slide the bolt through the lock washer. Push that assembly through the armor.
- Place a spacer over the threads and thread the bolt into the insert (shown here in green).
- Repeat the process with the passenger side armor (1110).

Torque Spec: **100 Inch Pounds**

**Step 5 (CONT)**  
**Armor to grooveTEK**

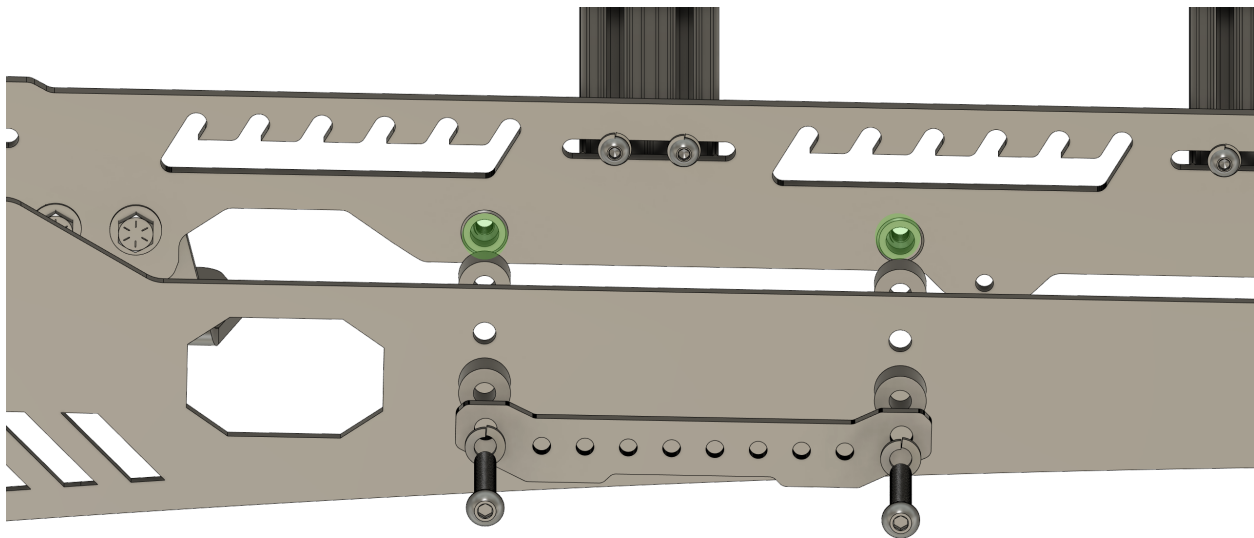

**Figure 16**  
**Grab Handle Lace Plates**  
**Armor grooveTEK/Driver Side Shown**

- 55mm Bolt (2)
  - 8mm Lock Washer (2)
  - Plastic Spacer (4)
  - This process will be repeated for each of the four (4) grab handles.
- 
- Using a 5mm Allen wrench slide the bolt through the lock washer. Push that assembly through one of holes on the lace plate.
  - Slide a spacer over the threads.
  - Pass that assembly through the armor.
  - Slide another spacer over the threads.
  - Thread that assembly into the insert in the grooveTEK (shown here in green).

Repeat for the remaining three (3) grab handles.

## STEP 6 Vehicle Preparation

If your vehicle is equipped with a factory roof rack it will need to be removed before completing any further steps. You will NOT reuse any supplied hardware from a factory or aftermarket roof rack. Catalog the parts and keep for reinstallation when you are finished with the vehicle.

### **NOTE**

Toyota Tacomas that come equipped with factory roof racks do not feature the drip rail covers. These can be ordered from Toyota as individual parts if you would like to have them. It will be helpful to have the VIN number of a truck that has them from the factory. At the time of this writing the two (2) factory part numbers for the gaskets are:

#### **2005-2015 (2nd Generation)**

**Left: 75552-04063**

**Right: 75551-04063**

#### **2016-Current (3rd Generation)**

**Left: 75552-04081**

**Right: 75551-04081**

*These parts are NOT required and will need to be modified but without them the drip rail channels at the front of the truck underneath the rack will be visible. You will need a hammer and 19mm (3/4") hollow tapered punch which can be ordered on Amazon.*

## DRIP RAIL PUNCH PROCESS

The link provided below contains the process that we use for punching the factory drip rail covers to allow the supplied spacers to fit through them. The assembly/installation of the rack is out of date and the steps in this guide should supersede the assembly of the rack in the video. The video is long winded but you can skip to 15:45 to see the process by itself.



## **STEP 6(CONT)**

### **Vehicle Preparation**

You are strongly encouraged to watch the video link on the previous page as it details the steps needed to prep the factory threaded insert attachment points for the roof rack.

***ALL 2005-Current Double Cab Toyota Tacoma trucks come equipped with threaded inserts in the drip rails of the truck. They are concealed by weatherproof tape that is painted to match the body color of the truck.***

You can locate these areas by running your fingers down the drip rails and finding the soft or “spongy” areas under those pieces of foam tape. Using a small razor blade carefully trim out the gasket material around those threaded inserts. It is possible with care to use the lip of the threaded insert as a guide to cut a near perfect hole.

**THE FOAM TAPE MUST BE REMOVED** from the threaded insert locations. If forced the foam tape will gum up the threads on the provided fasteners for attaching the roof rack to your vehicle and impede the silicon sealant from performing as intended.

- *Ensure the area around the vehicle is clear of obstruction (pets, power wheels, basketballs, small children, etc...) and that you can easily reach the driver and passenger side of the vehicle with a rack lifted over your head. If you are vertically challenged have readily accessible a step stool or ladder to assist getting the rack onto the vehicle.*
- *Fold the driver and passenger side mirrors into the vehicle (if capable) to free up some space and avoid damage while you are moving the rack assembly overhead.*
- *Place a moving blanket or other heavy, non-marring covering onto the roof of the vehicle so that you can sit the rack down once you have it upTOP ;) and reposition it into the final mounting location.*



## STEP 7 Final Installation

### GATHER THE FOLLOWING:

- 5mm Allen wrench
- Silicone Sealant
- Hardware Kit “Rack to Roof”
- Hardware Kit “Front Spacers”
- Hardware Kit “Rear Spacers”

Apply a generous amount of silicone sealant INTO the opening in the factory drip rail seals. Make sure the sealant enters the threaded inserts for the roof rack attachment points.

***If you decided to proceed without the drip rails fill the channel and area around the factory threaded inserts.***

Your kit includes two (2) different length spacers.

- **1.00” for the FRONT**
  - **.875” for the REAR**
- With the silicone sealant applied place one spacer over each of the threaded inserts in your roof. Twist them into position so that the spacer sits neatly into position. The silicone will help to keep the spacers aligned but may move when sitting the rack into place. Verify placement prior to attempting to insert any hardware.

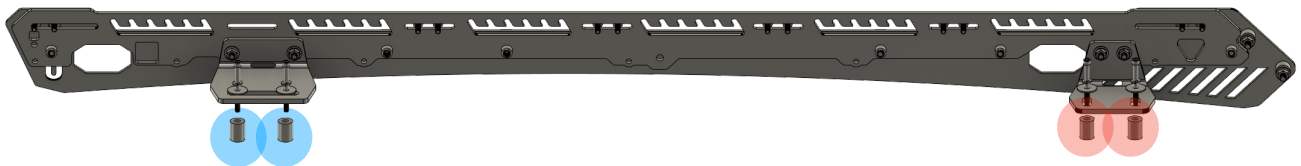

**Figure 14**  
**Alpha Tacoma 2/3G Spacer Placement.**  
**Driver Side Shown**

- The spacers highlighted in **BLUE** are 1.00” for the REAR.
- The spacers highlighted in **RED** are .875” for the FRONT.
- The spacer length will be the same for **BOTH SIDES OF THE VEHICLE.**

**STEP 7 (cont)**  
**Final Installation**

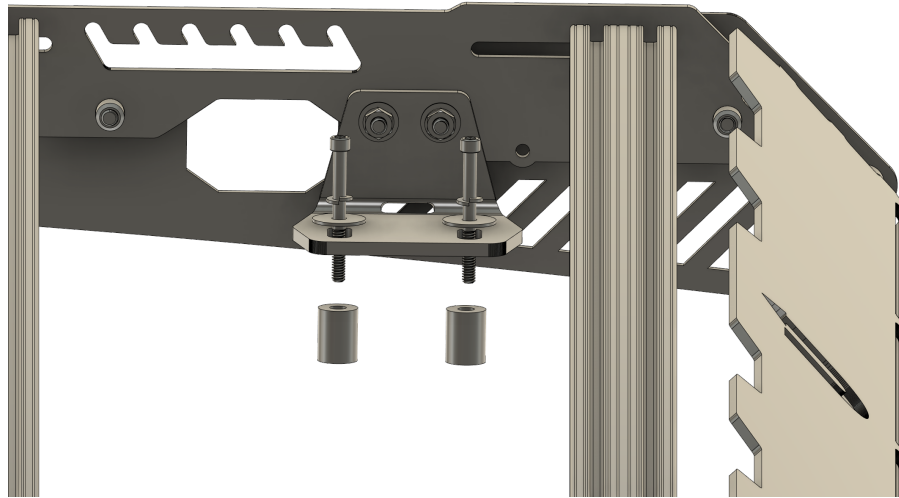

**Figure 15**  
**Tacoma 2/3G FRONT Foot 1305 Hardware**  
**Driver Side Shown**

- 55mm Bolt m6x1.00
- 6mm Lock Washer
- 6mm x 25mm Fender Washer

• Insert each hardware combination to match the order of assembly in Figure 15. Hand tighten with a 5mm Allen wrench. **DO NOT FULLY TIGHTEN** the hardware. Leave it loose to allow for adjustment. **REPEAT THE PROCESS** for the passenger side FRONT foot.

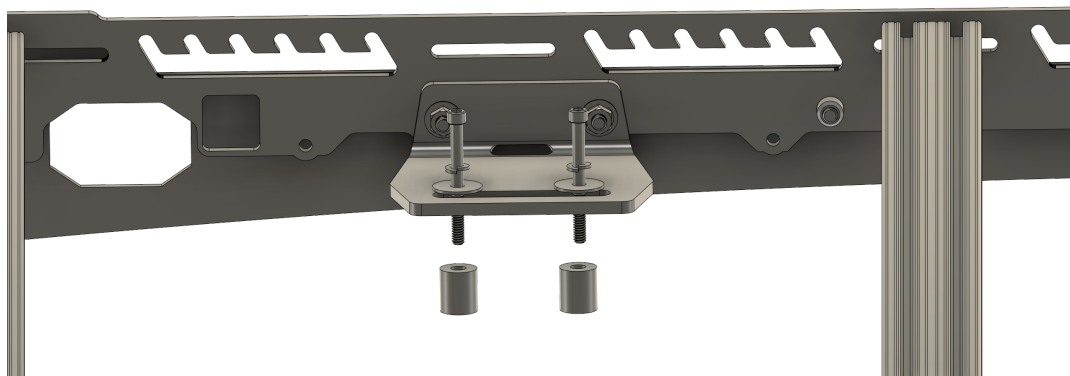

**Figure 16**  
**Alpha Tacoma 2/3G REAR Foot 1307 Hardware**  
**Driver Side Shown**

• Insert each hardware combination to match the order of assembly in Figure 16. Hand tighten with a 5mm Allen wrench, **DO NOT FULLY TIGHTEN** the hardware. Leave it loose to allow for adjustment. **REPEAT THE PROCESS** for the passenger side REAR foot.

## TECH TIP

The factory installed inserts can be stubborn. If you encounter more than a little resistance when tightening the hardware **STOP** and try to clear the threads. This can be accomplished by either using a tap or a hardened bolt.

### **THREAD PITCH IS M6x1.00**

**DO NOT FORCE THE FASTENERS.** *The stainless steel hardware is more than adequate for securing the rack to your vehicle but they may shear or seize when forced into damaged threads.*

**NEVER, EVER use power tools to insert the hardware that came with your upTOP rack system.**

## FINAL CHECKS

- Visually inspect the rack to make sure it is centered on the vehicle. Adjust as necessary and fully tighten the **RACK TO ROOF** hardware to **28 inch pounds**.
- Set your load bars to the desired locations and fully tighten the **LOAD BAR** hardware to **70 inch pounds**.
- Inspect the **FAIRING** and fully tighten to **130 inch pounds**.
- Adjust the light bar (if equipped) inside the fairing for final alignment. Tighten all hardware used to install the **LIGHT BAR** to **130 inch pounds**.
- Tidy up any wiring (if equipped) and make sure all your connections are secure.

## OPTIONAL Fairing Lighting Tutorial

A brief tutorial on the layout of spacers and hardware is available on our website by using this link:

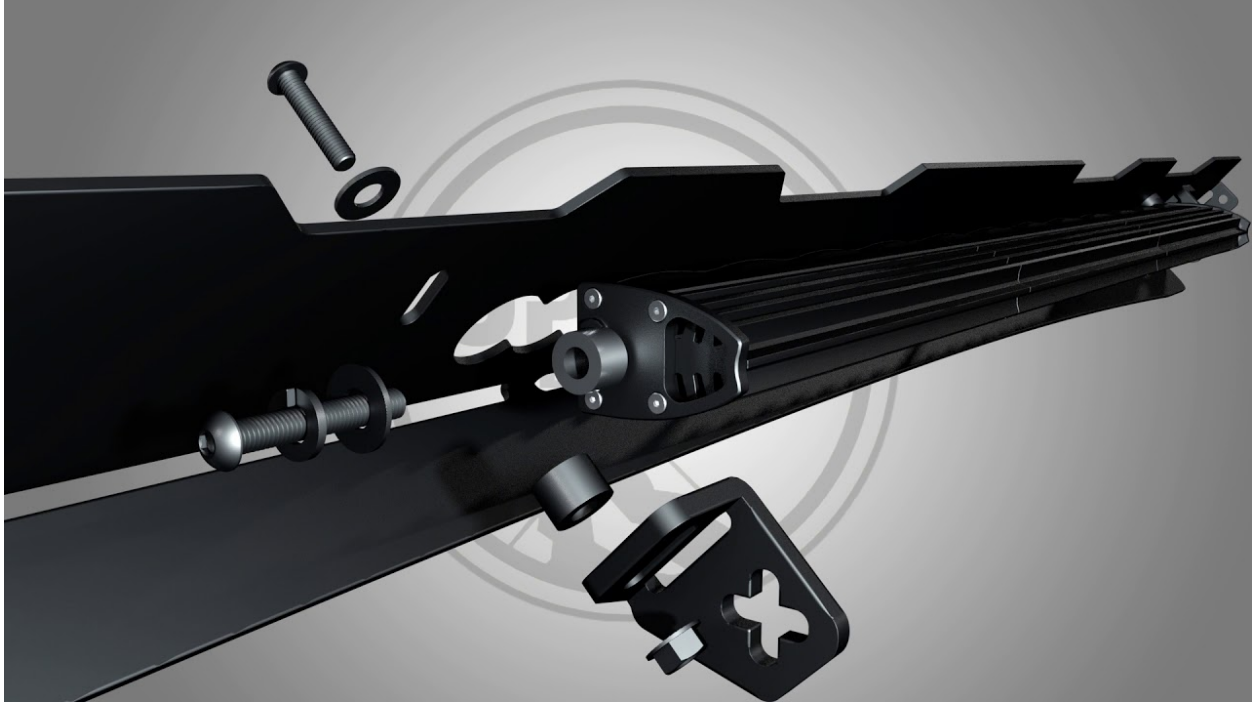

### NOTE

*The light bar shown in the video is an Extreme LED brand. The spacer inserted between the light bar and the mounting bracket (NOT THE BRACKET AND THE FAIRING) is NOT required or included with fairings cut for Baja Designs Light Bars.*

*The spacer is required on Extreme LED products to provide clearance for the cable gland where the wiring exits the light bar.*

- *Align the light bar so that the lenses are unobstructed by the openings in your fairing.*
- *Aim the light bar so as to eliminate hood glare.*

*Detailed instructions for all current upTOP wind screen options are available for download from our website.*

## OPTIONAL freshAIR Kit

To retain the functionality of a factory installed sun roof the optional freshAIR kit can be installed at any time.

The normal “open” feature of your sunroof is compatible with our Alpha roof rack with or without the freshAIR kit because the sunroof opens into the roof of the vehicle.

**The VENT feature is NOT compatible on the 2/3G Toyota Tacoma without installation of the freshAIR kit. Use of the VENT feature would cause the sun roof glass to come into contact with the THIRD load bar from the front of your roof rack possibly causing damage to the sunroof or the mechanism that operates it.**

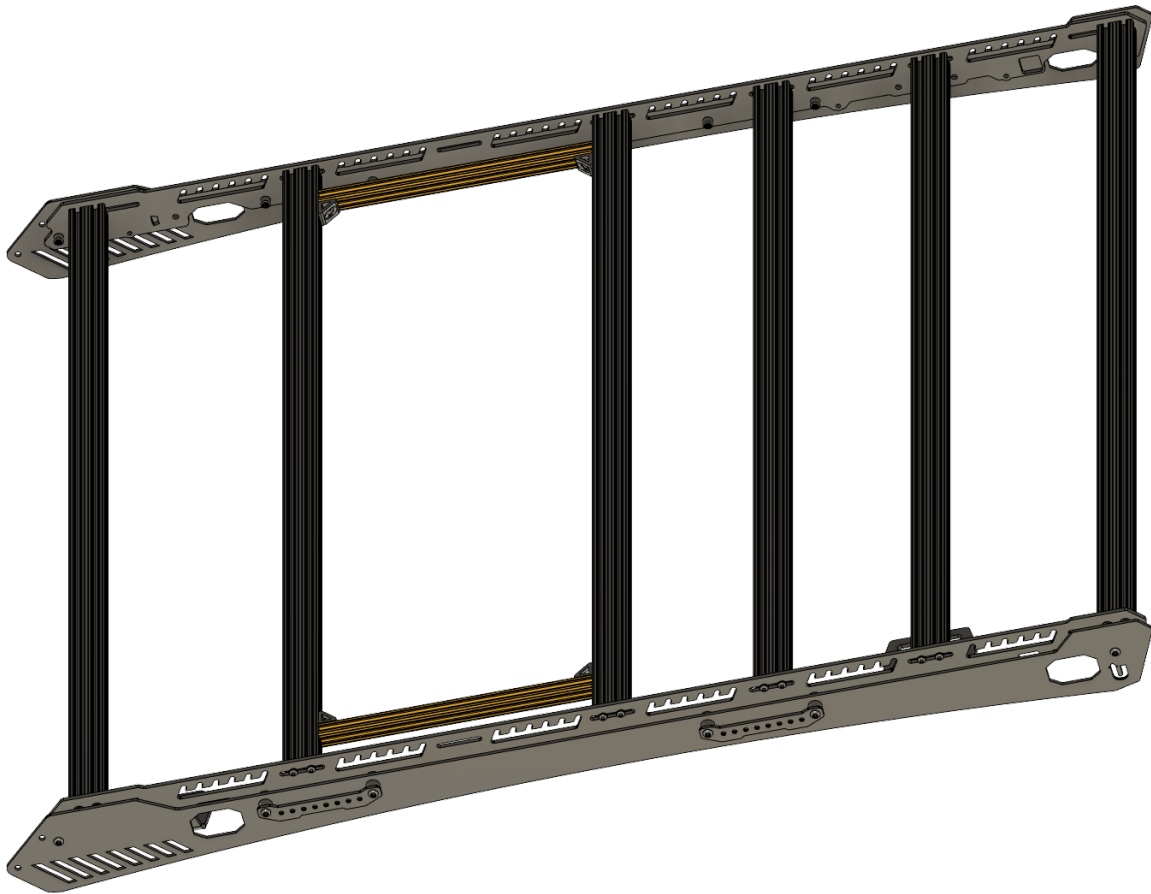

**Figure 17**  
**Alpha Tacoma 2/3G freshAIR**

To utilize the optional freshAIR kit you are required to remove the 3rd load bar from the front. You will also need to remove the load bar hardware (one end is adequate) from the 2nd and 4th load bar from the front so that you can insert the threaded inserts used to attach corner brackets to the freshAIR support bars.

The freshAIR bars feature extruded channels that are the same dimension as the grooves on your load bars allowing the same hardware type to be employed to use the freshAIR bars as attachment points for gear.

OPTIONAL (CONT)  
freshAIR

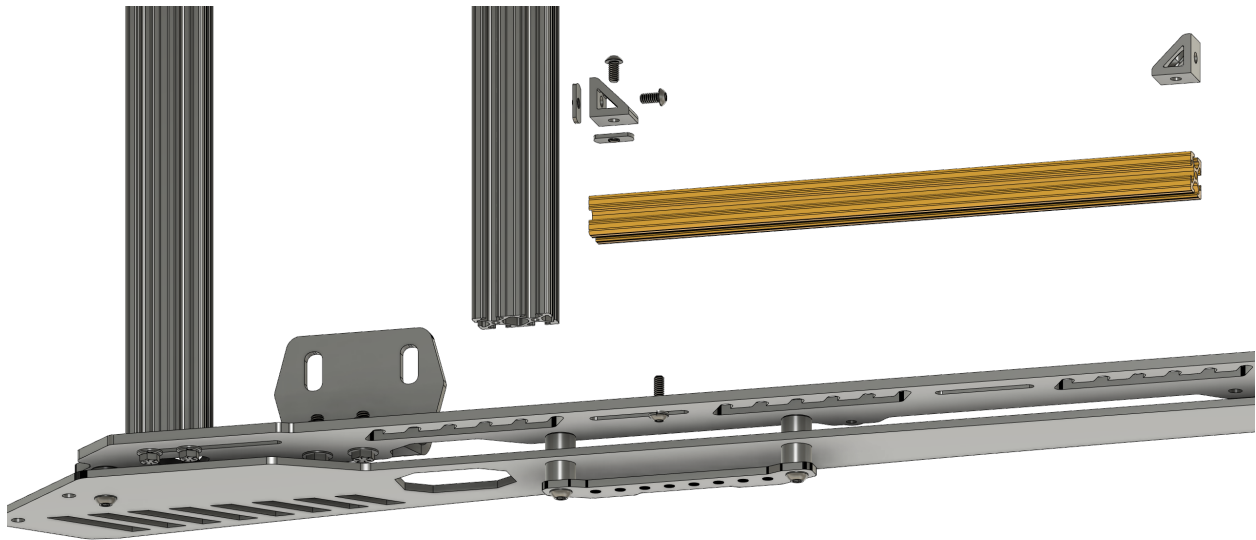

Figure 18  
Alpha Tacoma 2/3G freshAIR  
Driver Side Shown

- Remove the 3rd load bar from the front.
- Remove the button head bolts from the drivers side of the rack for the 2nd and 4th load bar.
- Insert two threaded inserts on the short side (1.00" Tall) side of the 2nd and 4th load bar from the front. These inserts will install on the side of the load bar closest to the sunroof.
  - The **REAR** of the 2nd Load Bar
  - The **FRONT** of the 4th Load Bar.
- Insert two threaded inserts into the freshAIR bar (shown in **YELLOW**).
- Use the supplied corner brackets and using a 5/32 Allen wrench line up and install one fastener to each threaded insert.
- Repeat the process on the passenger side. It is **NOT** required to remove the hardware from 2nd and 4th load bar on the passenger side. You installed enough threaded inserts into the drivers side to slide them across to the passenger side of the vehicle.
- Adjust the width of the freshAIR bars to "frame" in your sunroof area leaving adequate clearance for the sunroof to operate normally.

**NOTE**

If your order was placed with the request for freshAIR kit your kit will only include six (6) 50" Load bars.

## **upTOP finePRINT**

- **It is recommended to inspect the rack hardware at regular intervals to ensure fasteners are tight. If the rack ever needs to be removed and reinstalled you will need to repeat the silicone sealant steps before reinstallation of the rack to roof hardware.**
- **The powder coated finish on your rack uses a chemical compound to maintain UV stability for years to come. Wash the roof rack at regular intervals to keep the load bar channels, drip rails and mounting components free of dirt and debris. Foreign objects (mud) can dry and cause noise and vibration.**
- **If your color matched components are painted care for them in the same manner as you care for the exterior finish of your vehicle.**
- **Repair or replace worn parts with expediency. All hardware is available for purchase by calling our technical support line at 720.730.6381 Monday-Friday 8am to 4pm MDT or by email 24/7 364 (we don't answer email on Christmas-get over it) support@uptopverland.com**
- **It is the responsibility of the end user to ensure all electrical connections are secured and fused properly for the circuit load they are carrying.**
- **upTOP Roof Rack dynamic (moving) weight capacity can often exceed the OEM vehicle manufacturers specification. In all cases the OEM specifications supersede the upTOP dynamic rated load capacity.**
- **DO NOT use the upTOP product in a manner inconsistent with its design intention. This will void your warranty.**
- **DO NOT modify or alter structural components of upTOP roof rack assemblies. This will void your warranty.**
- **Excessive speeds over rough terrain can exceed dynamic weight loads causing structural fatigue or failure of aluminum and steel components. Use your best judgement and common sense before committing to full send with an overloaded rack product.**
- **Component damage or failure due to negligence will result in voided warranty claims. Any failed component must be returned to upTOP with a properly submitted RMA request. Any product received without authorized RMA request will be returned to sender at their expense.**
- **Leave. No. Trace. Our planet is fragile. Some parts of it have been undisturbed for generations. Stay on trails and designated routes. DO NOT LITTER. Pack it in Pack it out. Basically be a decent human and protect our culture, wild lands and ecosystems.**

## **REVISIONS**

Updated 1069/1070 grooveTEK for M8x1.25 Zinc Plated rivNUT 1.4.21

Updated to steel feet. 1.21.21

Revised freshAIR hardware 1.24.21

Grammar correction 1.25.21

Updated to grooveTEK integrated wind screen 2.26.21

Added informational link for integrated wind screen lighting installation. 3.5.21

Updated torque specifications to 18-8 SS 3.19.21

Revised and added notes for hardware changes/upgrades to components. 4.10.23

Revised internal documentation for BOM to reflect black hardware and grab handle 2.0 included with kit. 4.28.23