

Container Door Flashing Kit

Prior to Starting

- Ensure use of proper PPE; steel-toed footwear, cut resistant work gloves, and eye protection.
- Ensure tools are in good working condition.
- Remove any unnecessary clutter from the workspace.
- Read and understand all instructions before beginning.

Tools Required

- Drill.
- Rivet Gun.
- Workbench or clean flat surface.

Parts Included

- Standard or High Cube container door flashing assembly, detailed list below.
- 3/16" rivets.
- No.10 self tapping screws.

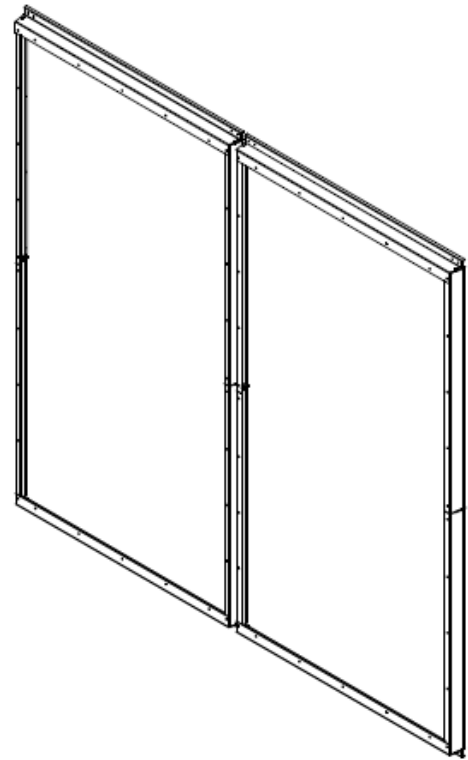

Standard Container Door Flashing Kit Assembly			
ITEM	QTY	PART NUMBER	DESCRIPTION
1	8	CMW-4-410-0108	Standard Vertical Flashing - 2 piece
2	4	CMW-4-410-0107	Container Door Flashing Header/Footer

High Cube Container Door Flashing Kit Assembly			
ITEM	QTY	PART NUMBER	DESCRIPTION
1	8	CMW-4-410-0109	High Cube Vertical Flashing - 2 piece

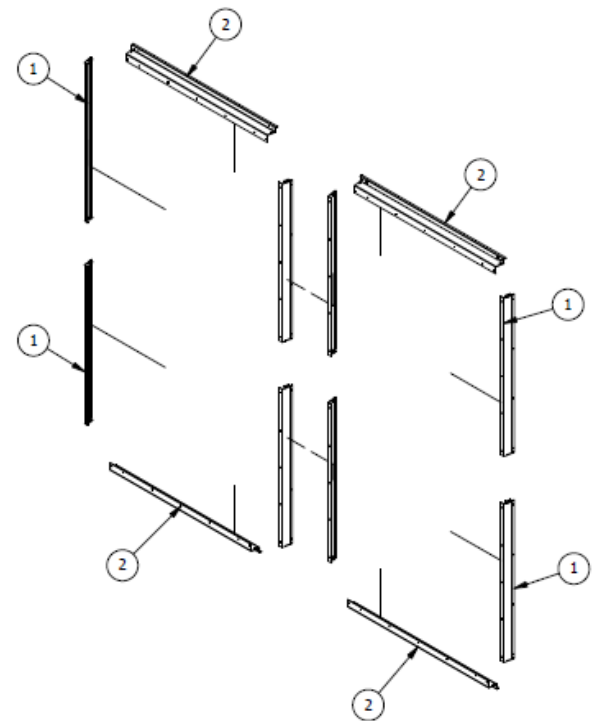

2	4	CMW-4-410-0107	Container Door Flashing Header/Footer
---	---	----------------	---------------------------------------

Step 1

Layout flashing components as shown in Figure 1. Ensure rivet tabs align.

Step 2

Assemble the side flashing by connecting two Vertical Flashing pieces (CMW-4-410-0108/9) with the provided 3/16" rivets. Repeat steps for each side. Figure 2.

Step 3

Connect the side flashings to the header flashing using the provided 3/16" rivets. Figure 3.

Step 4

Connect the side flashings to the footer flashing using the provided 3/16" rivets. Figure 4.

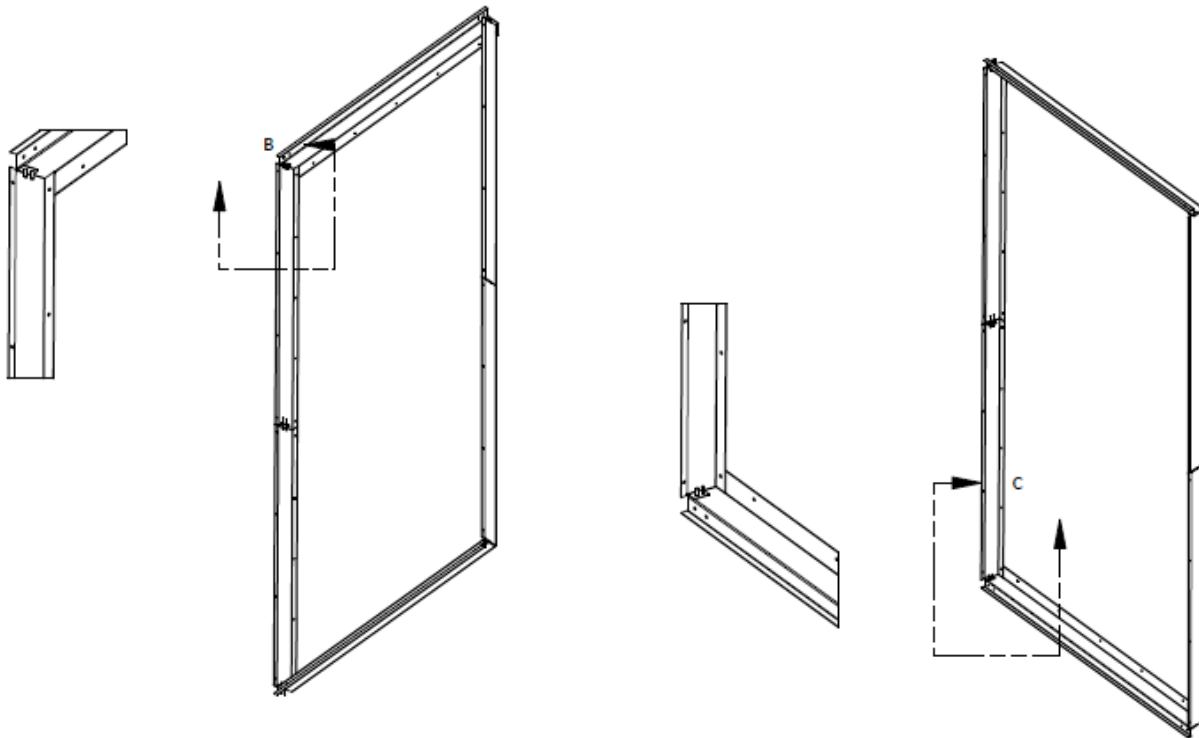

Figure 2 - Top and bottom side riveted together

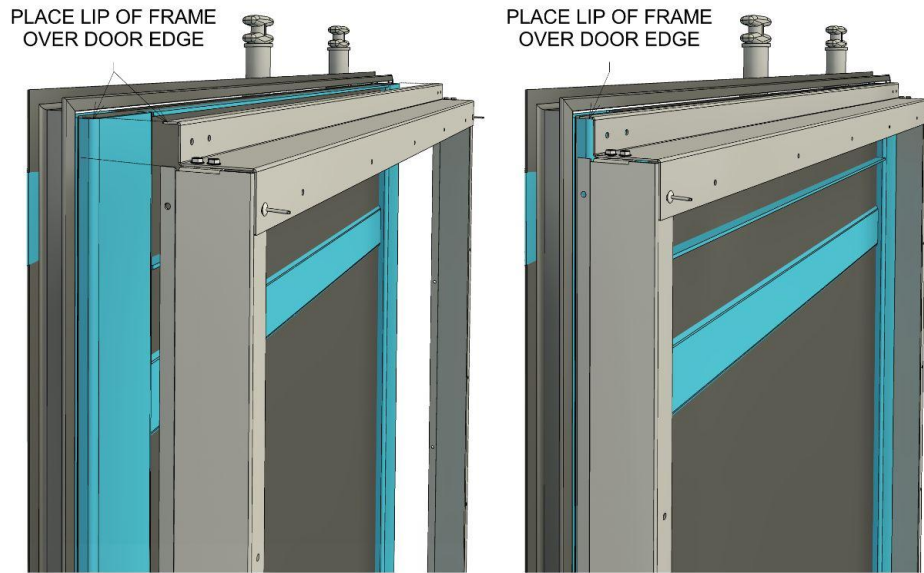

Figure 3 - Top sides connected to header

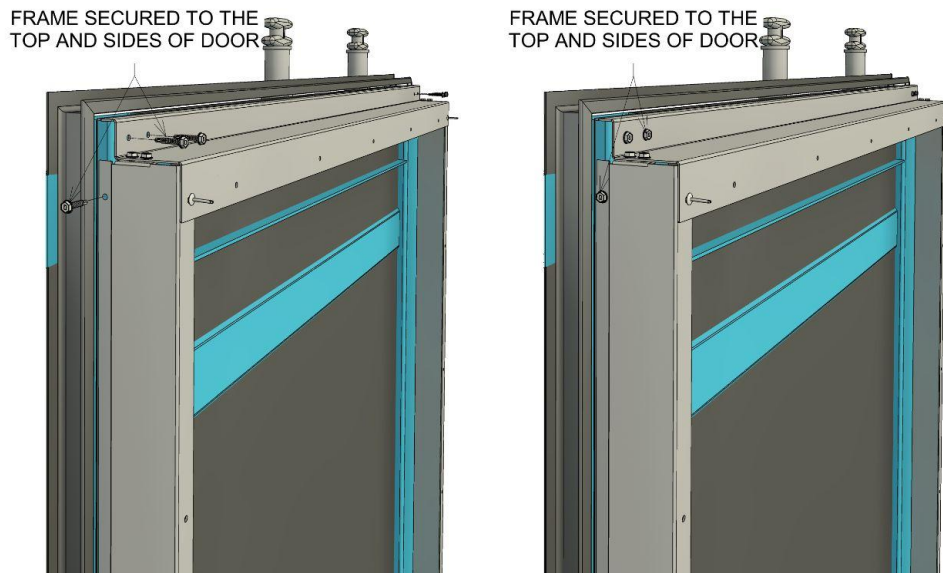

Figure 4 - Flashing Kit Installation Container Door from Top



Figure 5 - Bottom sides connected to footer



Figure 6 - Flashing Kit Installation Container Door Bottom

Step 5

Lift the flashing assembly and place it on the container door top lip as shown in Figure 4. Fasten the flashing to the container door with the provided No.10 screws through the pre-drilled holes. Continue fastening the sides and bottom. Figure 5&6.

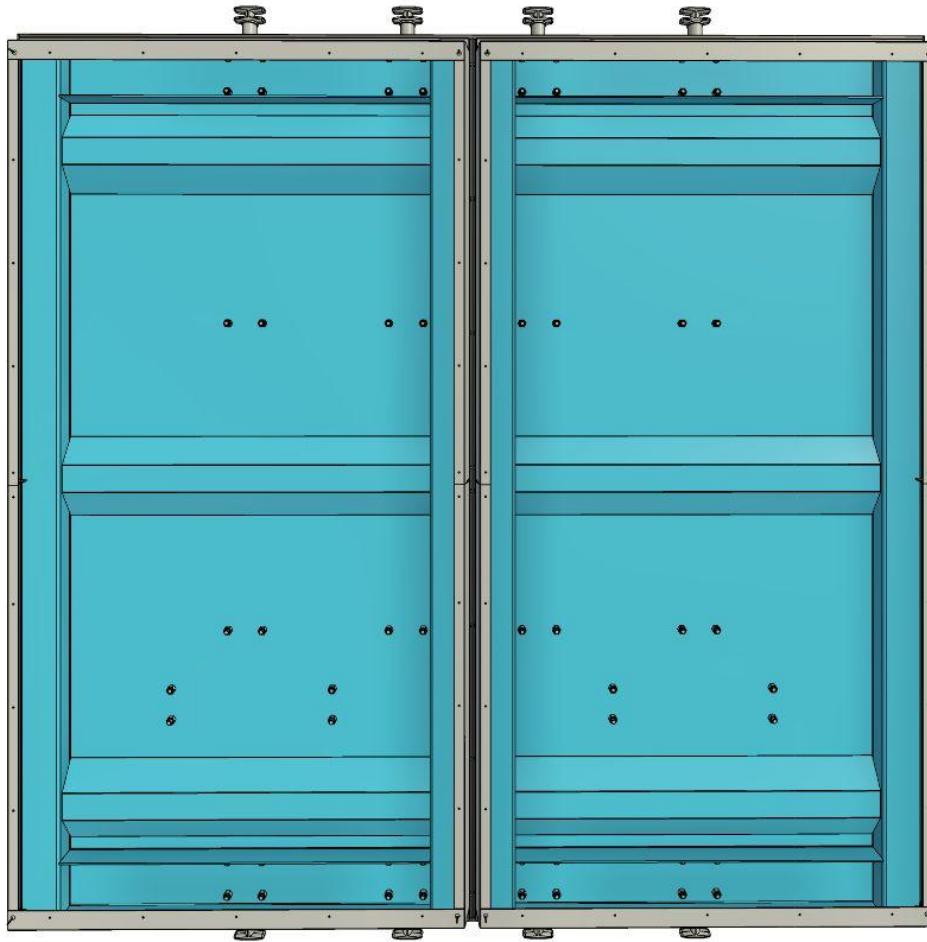

Figure 7 - Container Door Flashing Kit Installed on Container Door

Step 6

Follow Steps 1 through 5 to complete the second door.