

Big Air 45 Installation Instructions

Before You Begin

- Make sure you use proper PPE; steel-toed footwear, work gloves, eye protection.
- Ensure your tools are in good working condition.
- Read & understand all instructions before beginning.

What you will need

- 3/16" Driver / Power Drill / Rivet Gun
- Caulking Gun
- Zip Cutter

What is included

- Big Air 45 X 2
- Pack of Rivets / Pack of self tapping screw X 10
- Marking Sheet

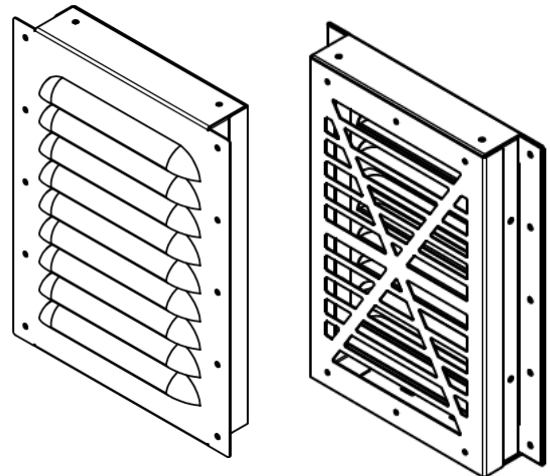

Figure 1 - Big Air 45 (optional screen shown)

Installation

Before starting the process of installation please take a note that :

- Big Air 45 is corrugation dependent. It can only be installed on outside corrugation.
- Rivets are recommended to install the vent.

Step 1

Select the area of cut out and make it clean. Always center the cut out to the Inner corrugation. Mark the cut out using the cut out paper template given with kit. Decide the location if you want to install the vent at the top or bottom and maintain the minimum distance as shown in figure 2 & figure 3.

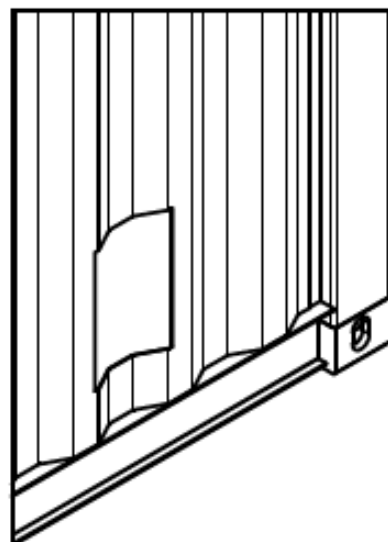
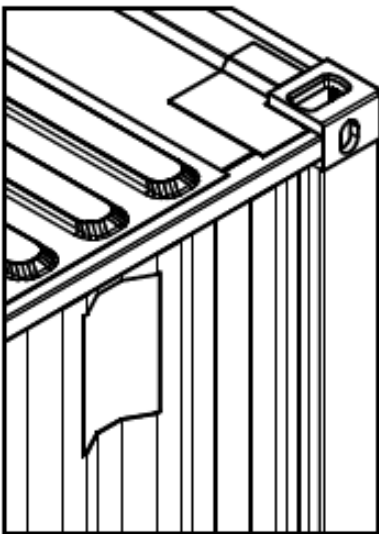
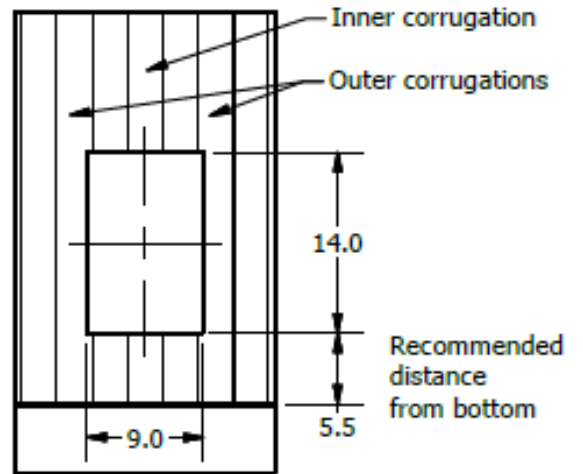
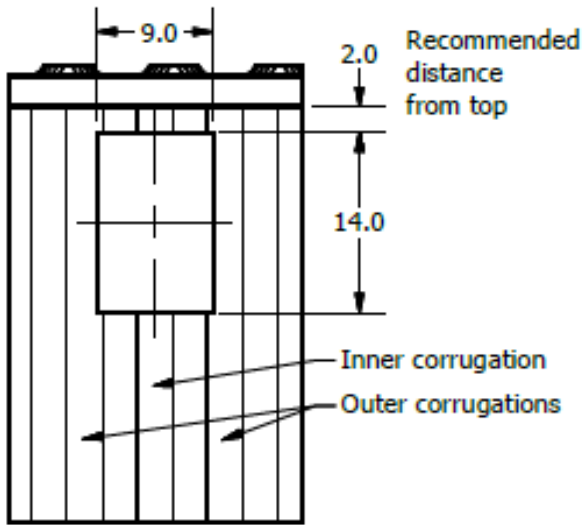

Figure 2 - Cut out position from top

Figure 3 - Cut out position from bottom

Step 2

Put the Big Air 45 vent in the cut-out as shown in fig.4 and drill the holes by taking the reference of pre-lasered holes on the vent as shown in fig 5.

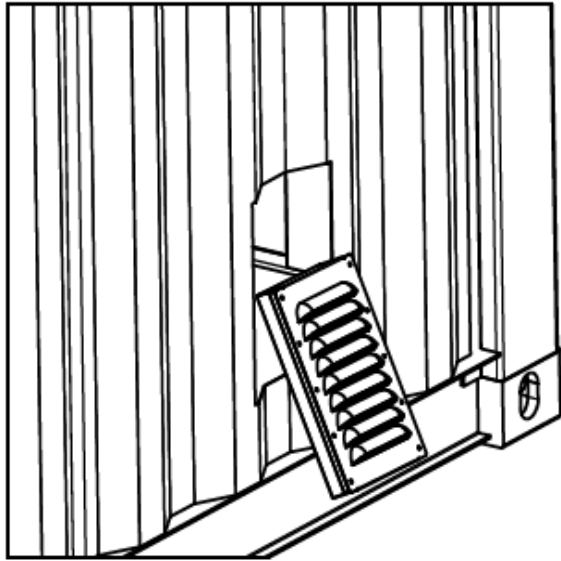

Figure 4 - Put vent in cut out

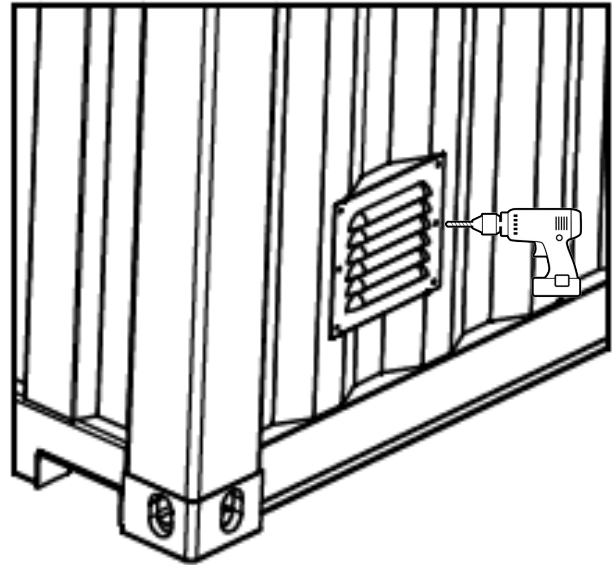

Figure 5 - Drill the hole in container

Step 3

Rivet or screw in the vent to the container wall as shown in fig 6.

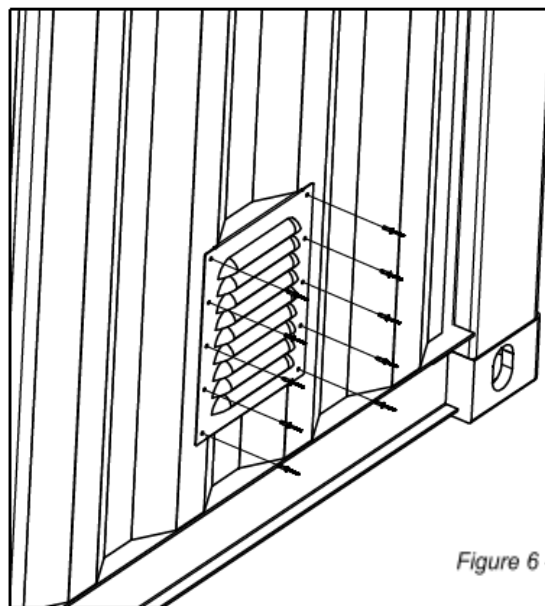

Figure 6 - Rivet the vent

Step 4

Apply silicon all around the vent to ensure the vent is properly sealed. Also apply the silicon from inside the container over the fasteners that are penetrating the corrugation.

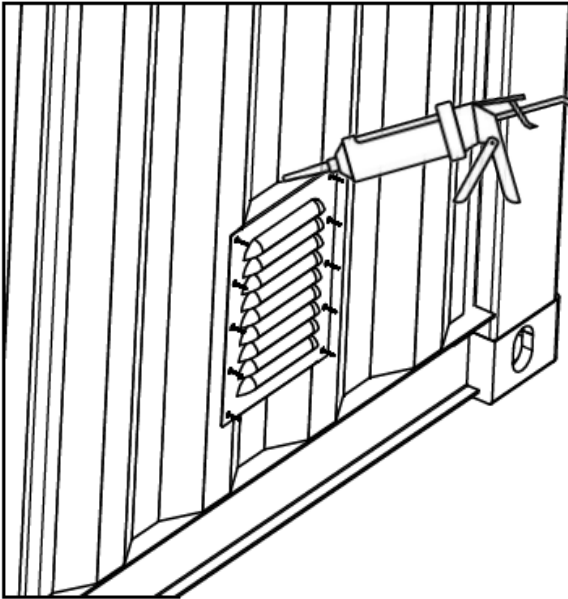

Figure 7 - silicon from outside of the container

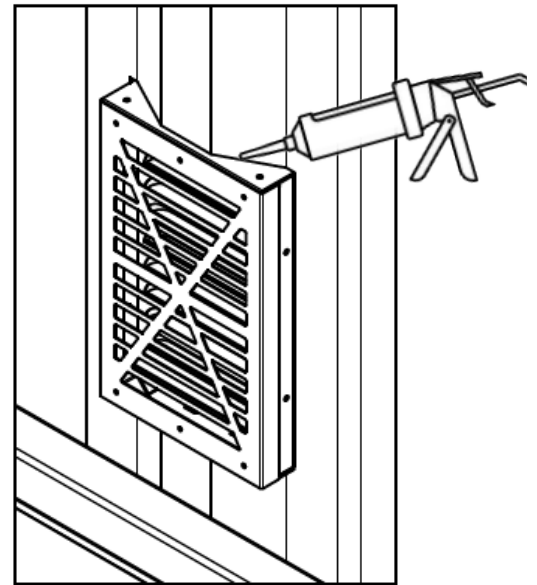

Figure 8 - Silicon from inside of the container

Additional Information

An in-depth installation video can be viewed by scanning the code below with your phone's camera.

Visit containermodificationworld.com for more resources and product catalogs.

