

# KitchenAid®

**ROOMIJSMAKER**  
INSTRUCTIES EN RECEPTEN

**ICE CREAM MAKER**  
INSTRUCTIONS AND RECIPES

**SORBETIÈRE**  
MODE D'EMPLOI ET RECETTES

**SPEISEEISMASCHINE**  
BEDIENUNGSANLEITUNG UND REZEPTE

**GELATIERA**  
ISTRUZIONI PER L'USO E RICETTE

**HELADERA**  
INSTRUCCIONES Y RECETAS

**GLASSMASKIN**  
INSTRUKTIONER OCH RECEPT

**ISKREM-MASKIN**  
BRUKSANVISNING OG OPPSKRIFTER

**JÄÄTELÖKONE**  
KÄYTTÖOHJEET JA RESEPTIT

**ISMASKINE**  
INSTRUKTIONER OG OPSKRIFTER

**SORVETEIRA**  
INSTRUÇÕES E RECEITAS

**ÍSGERÐARTÆKI**  
LEIÐBEININGAR OG UPPSKRIFTIR

**ΠΑΓΩΤΟΜΗΧΑΝΗ**  
ΟΔΗΓΙΕΣ ΚΑΙ ΣΥΝΤΑΓΕΣ

English



**Model 5KICA0WH**  
**Ice Cream Maker**  
Designed exclusively for use with all  
KitchenAid® Household Stand Mixers.

# Table of Contents

---

English

Ice Cream Maker Safety .....	1
Important Safeguards .....	1
Ice Cream Maker Features .....	2
Assembling the Ice Cream Maker Attachment for Tilt-Head Mixer.....	3
Assembling the Ice Cream Maker Attachment for Bowl-Lift Mixer .....	5
Using the Ice Cream Maker Attachment .....	7
Tips for Making Perfect Ice Cream.....	7
Care and Cleaning .....	8
Recipes .....	8
KitchenAid® Household Stand Mixer Attachment Warranty .....	13
Service Centers.....	13
Customer Service .....	14

# Ice Cream Maker Safety

## Your safety and the safety of others are very important.

We have provided many important safety messages in this manual and on your appliance. Always read and obey all safety messages.



This is the safety alert symbol.

This symbol alerts you to potential hazards that can kill or hurt you and others.

All safety messages will follow the safety alert symbol and either the word “DANGER” or “WARNING.” These words mean:

**! DANGER**

**You can be killed or seriously injured if you don't immediately follow instructions.**

**! WARNING**

**You can be killed or seriously injured if you don't follow instructions.**

All safety messages will tell you what the potential hazard is, tell you how to reduce the chance of injury, and tell you what can happen if the instructions are not followed.

English

## IMPORTANT SAFEGUARDS

When using electrical appliances, basic safety precautions should always be followed including the following:

1. Read all instructions.
2. To protect against risk of electrical shock, do not put mixer in water or other liquid.
3. The appliance is not intended for use by young children or infirm persons without supervision.
4. Unplug from outlet when not in use, before putting on or taking off parts, and before cleaning.
5. Avoid contacting moving parts. Keep fingers out of discharge opening.
6. Do not operate the mixer with a damaged cord or plug or after the mixer malfunctions, or is dropped or damaged in any manner. Return the mixer to the nearest Authorized Service Center for examination, repair or electrical or mechanical adjustment.
7. The use of attachments not recommended or sold by KitchenAid may cause fire, electric shock or injury.
8. Do not use the mixer outdoors.
9. Do not let the cord hang over the edge of table or counter.
10. This product is designed for household use only.

## SAVE THESE INSTRUCTIONS

# Ice Cream Maker Features

---

English



**Freeze Bowl** — Once completely frozen, liquid within the double walls of the bowl provides thorough, even freezing of ice cream batter throughout the mixing process.

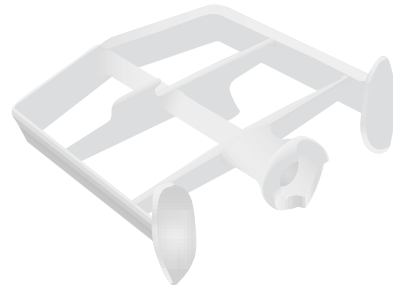

**Dasher** — Engages with the drive assembly to spread, scrape and mix ice cream batter within the freeze bowl.

**NOTE:** The freeze bowl must be completely frozen to make ice cream.

**IMPORTANT:** Never wash the freeze bowl in dishwasher.

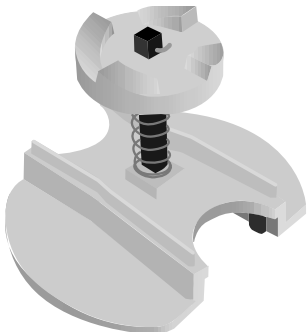

**Drive Assembly** — Attaches to the motor head, above the ring on the beater shaft, and drives dasher on all European KitchenAid® Stand Mixers.

# Assembling the Ice Cream Maker Attachment for Tilt-Head Mixer\*



## To Assemble Freeze Bowl and Dasher:

**NOTE:** Use the freeze bowl immediately upon removal from freezer, as it begins to thaw once removed.

**IMPORTANT:** Do not pour ice cream batter into the freeze bowl until all parts are assembled and the mixer is running.

1. Turn stand mixer speed-control to "O" (off) and unplug mixer.
2. Tilt motor head back and remove mixing bowl.
3. Place dasher inside the freeze bowl.

4. Place the freeze bowl on bowl-clamping plate.
5. Gently turn the freeze bowl in counterclockwise direction (in direction of ) to secure. The freeze bowl should fit the bowl-clamping plate tightly.



English

\* For bowl-lift mixer, see page 5 and 6.

# Assembling the Ice Cream Maker Attachment for Tilt-Head Mixer\*

English

## To Attach Drive-Assembly:

1. Be sure speed-control is still on "0" (off) and mixer is unplugged.
2. Motor head should still be tilted, and the freeze bowl and dasher should be in place.
3. Determine your mixer model by checking for a spring on the beater shaft, and then position the drive assembly as illustrated for proper placement.

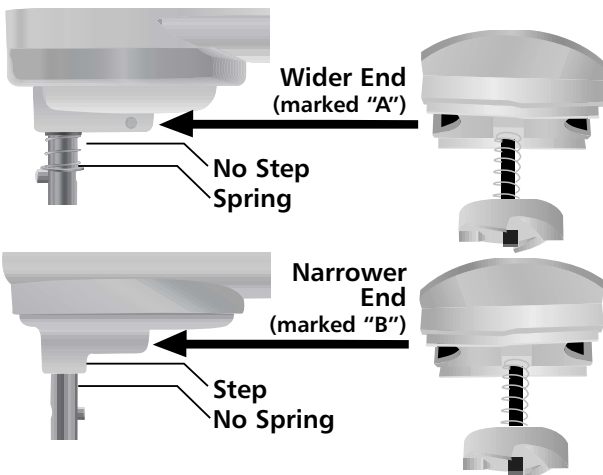

4. Slide drive assembly onto the motor head until it will not slide any further. When properly assembled, the outer curved edges of the drive assembly should center on the motor head. If they are not centered, slide the drive assembly either back or forward until it is centered on the motor head. Make sure the drive assembly is securely in place by pressing upward.

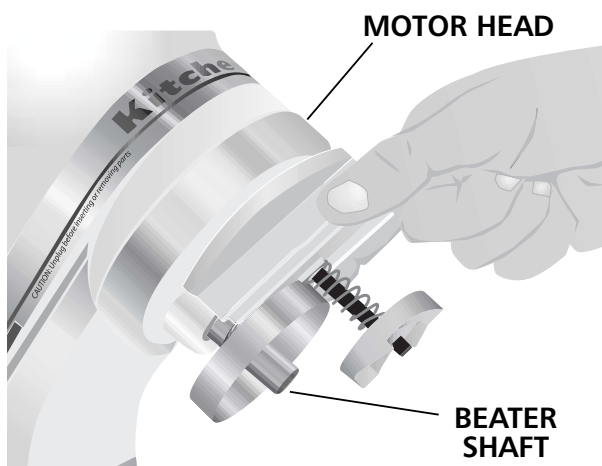

**NOTE:** If drive assembly will not fit onto the motor head, try using the other side of the drive assembly.

5. Lower the motor head to engage the drive assembly with the dasher. If the drive assembly doesn't engage the dasher, slide the drive assembly either back or forward until it does engage the dasher properly.



6. Make sure the motor head is down completely.



7. Place locking lever in the LOCK position.
8. Before mixing, test the lock by attempting to raise the motor head.
9. Plug the mixer into a grounded 3-prong outlet.

\* For bowl-lift mixer, see page 5 and 6.

# Assembling the Ice Cream Maker Attachment for Bowl-Lift Mixer\*



**NOTE:** The freeze bowl is designed to fit all bowl-lift mixers. If the bowl pin at the back of the bowl is too short or too long to snap into the spring latch, remove and rotate the bowl so the opposite bowl pin faces the spring latch. Repeat steps 3 and 4.

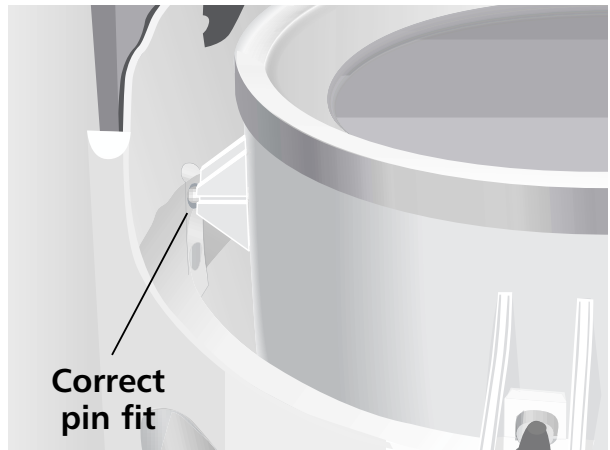
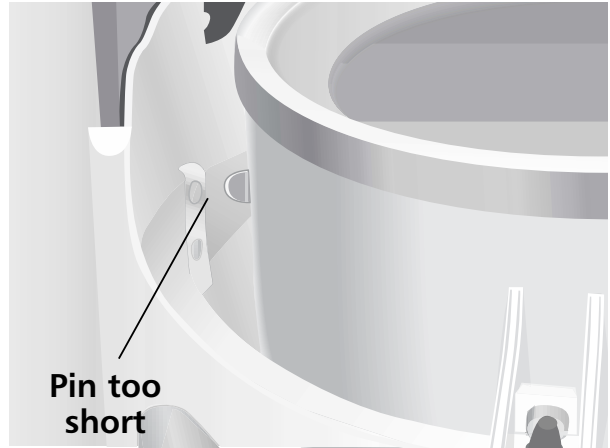

## To Assemble Freeze Bowl and Dasher:

**NOTE:** Use the freeze bowl immediately upon removal from the freezer, as it begins to thaw once removed.

**IMPORTANT:** Do not pour ice cream batter into the freeze bowl until all parts are assembled and the mixer is running.

1. Turn stand mixer speed-control to "O" (off) and unplug mixer.
2. Place bowl-lift handle in down position and remove mixing bowl.
3. Fit the freeze bowl into place over the locating pins.
4. Press down on the back of the freeze bowl until the bowl pin snaps into the spring latch.

5. Place the dasher inside the freeze bowl.



\* For tilt-head mixer, see page 3 and 4.

# Assembling the Ice Cream Maker Attachment for Bowl-Lift Mixer\*

English

## To Attach Drive Assembly:

1. Be sure the speed-control is still on "0" (off) and the mixer is unplugged.
2. Make sure the bowl-lift handle is still in the down position, and the freeze bowl and dasher are in place.
3. Determine your mixer model by checking for a spring on the beater shaft, then position the drive assembly as illustrated for proper placement.

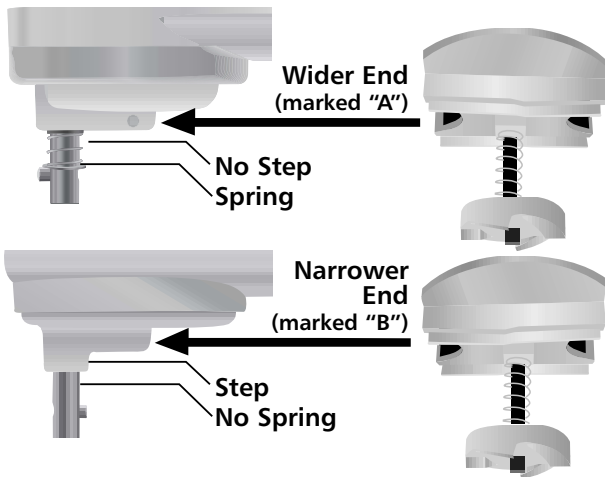

4. Slide drive assembly onto the motor head until it will not slide any further. When properly assembled, the outer curved edges of the drive assembly should center on the motor head. If they are not centered, slide the drive assembly either back or forward until it is centered on the motor head. Make sure the drive assembly is securely in place by pressing upward.

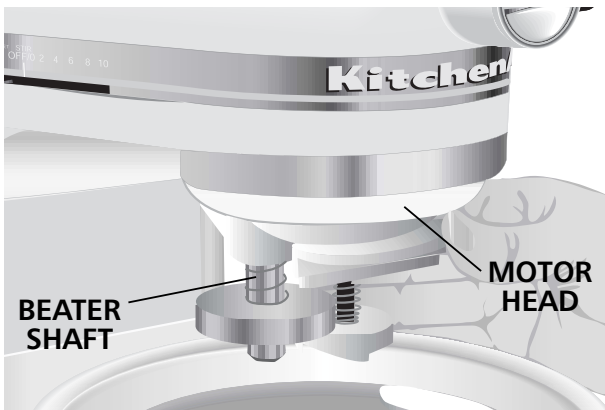

**NOTE:** If drive assembly will not fit onto the motor head, try using the other side of the drive assembly.

5. Raise the bowl to engage the dasher with the drive assembly before mixing. If the drive assembly doesn't engage the dasher, slide the drive assembly either back or forward until it does engage the dasher properly.



6. Plug the mixer into a grounded 3-prong outlet.

\* For tilt-head mixer, see page 3 and 4.



# Using the Ice Cream Maker Attachment

## To Use:

**IMPORTANT:** Pouring batter into the freeze bowl before starting the mixer may cause the batter to freeze prematurely and lock the dasher.

1. Store the freeze bowl in the freezer for a minimum of 15 hours.
2. Prepare ice cream batter in advance (see "Tips for Perfect Ice Cream").
3. Assemble and engage the freeze bowl, dasher, and drive assembly.
4. Set the mixer to speed 1 (STIR) and pour the ice cream batter into the freeze bowl; mix 20-30 minutes, or to desired consistency. Add any solid ingredients such as fruits, nuts, candies, or chocolate chips, after 12-15 minutes of the mixing process.

**NOTE:** If the dasher begins to slip and make a clicking noise, this is an audible indicator that the ice cream is done.

5. Remove the dasher and the freeze bowl and, using a rubber spatula or a plastic or wooden spoon, transfer ice cream to dessert dishes or to an airtight container for storage.

**NOTE:** The Ice Cream Maker Attachment will create a soft-consistency ice cream. For firmer consistency, store ice cream in an airtight container in the freezer for 2-4 hours.

**IMPORTANT:** Do not store ice cream in the freeze bowl in the freezer. Prying hard ice cream out of the freeze bowl with metal scoops or utensils may damage the freeze bowl.

## Tips for Making Perfect Ice Cream

- The freeze bowl must be completely frozen to make ice cream or other frozen desserts.
- For best results, store the freeze bowl in the back of your freezer where the temperature is coldest for at least 15 hours. Adjusting your freezer to its coldest setting will help the freeze bowl make firmer ice cream faster.
- Storing the freeze bowl in the freezer at all times allows you the flexibility to make your favorite frozen desserts on a whim.
- For recipes that need to be pre-cooked, allow the mixture to cool completely in the refrigerator.
- All batter recipes need to be completely chilled in the refrigerator before making ice cream.
- Most ice cream recipes call for a combination of cream, milk, eggs, and sugar. The type of cream you choose will determine how rich in flavor and how creamy the texture of the finished result. The higher percentage of fat in the cream, the richer and creamier your ice cream will be.

Any combination can be used, as long as the liquid measurement stays the same. Lighter ice creams can be made by using more milk than cream, or by eliminating cream. Skim milk will work, but there will be a noticeable difference in texture.

TYPE OF CREAM	FAT %
Heavy Cream .....	36%
Whipping Cream .....	30%
Light Cream .....	18%
Half and Half .....	10%

- When mixing an ice cream recipe that calls for solid ingredients such as fruits, nuts, candies, or chocolate chips, it is best to wait until the final two minutes of the mixing process to add them.
- Ice cream making is a two-part process: conversion and ripening. Mixing batter into ice cream is the conversion process in which the ice cream consistency will be similar to soft serve. The ripening process takes place in the freezer, where the ice cream will harden over a period of 2-4 hours.

*(continued on page 8)*

# Tips for Making Perfect Ice Cream (continued)

- Follow recommended mixer speeds. Faster speeds will slow the conversion process.
- Batter volume grows significantly during the conversion process.
- Initial batter volume should not exceed 1.365 L to produce 1,9 L of ice cream.
- Keep in mind that freezing subdues sweetness, so recipes won't taste quite as sweet once they are frozen.

## Care and Cleaning

Allow the freeze bowl to reach room temperature before attempting to clean it.

The drive assembly and dasher are dishwasher safe.

Wash the freeze bowl in warm water with mild detergent. Thoroughly dry the freeze bowl before storing in freezer.

**IMPORTANT:** Never wash the freeze bowl in the dishwasher. Hand-wash with warm water and mild detergent only.

## French Vanilla Ice Cream

600 mL (2½ cups) half-and-half  
8 egg yolks  
230 g (1 cup) sugar  
600 mL (2½ cups) whipping cream  
4 teaspoons vanilla  
A pinch of salt

In medium saucepan over medium heat, heat half-and-half until very hot but not boiling, stirring often. Remove from heat; set aside.

Place egg yolks and sugar in mixer bowl. Attach bowl and wire whip to mixer. Turn to Speed 2 and mix about 30 seconds, or until well blended and slightly thickened. Continuing on Speed 2, very gradually add half-and-half; mix until blended. Return half-and-half mixture to medium saucepan; cook over medium heat until small bubbles form around edge and mixture is steamy, stirring constantly. Do not boil. Transfer half-and-half mixture into large bowl; stir in whipping cream, vanilla, and salt. Cover and chill thoroughly, at least 8 hours.

Assemble and engage freeze bowl, dasher, and drive assembly as directed in attachment instructions. Turn to STIR Speed (Speed 1). Using a container with a spout, pour mixture into freeze bowl. Continue on STIR (Speed 1) for 15 to 20 minutes or until desired consistency. Immediately transfer ice cream into serving dishes, or freeze in an airtight container.

Yield: 16 servings (120 mL [½ cup] per serving).

### VARIATIONS

#### Fresh Strawberry Ice Cream

In medium bowl, combine 2 cups (500 g) chopped, fresh strawberries (or other fresh fruit) and 2 to 3 teaspoons sugar, if desired. Let stand while ice cream is processing. Add during last 3 to 5 minutes of freeze time.

Yield: 20 servings (120 mL [½ cup] per serving).

# French Vanilla Ice Cream (continued)

## VARIATIONS

### Cookies 'n Cream Ice Cream

Add 100 g (½ cup) chopped, cream-filled chocolate sandwich cookies (or other cookies, nuts, or candy) during last 1 to 2 minutes of freeze time.

Yield: 19 servings (120 mL [½ cup] per serving).

## Triple Chocolate Ice Cream

- 450 mL (2 cups) whipping cream, divided
- 1 square (30 g [1 oz.]) extra-dark chocolate, cut into chunks
- 1 square (30 g [1 oz.]) dark chocolate, cut into chunks
- 450 mL (2 cups) half-and-half
- 230 g (1 cup) sugar
- 40 g unsweetened cocoa powder
- 8 egg yolks
- 4 teaspoons vanilla
- A pinch of salt
- 1 bar (50 g [1.55 oz.]) milk chocolate, chopped

In small saucepan, place 120 mL whipping cream, extra-dark chocolate, and dark chocolate. Heat over medium-low heat until chocolate melts, stirring frequently. Remove from heat; set aside. In medium saucepan over medium heat, heat half-and-half until very hot but not boiling, stirring often. Remove from heat; set aside.

In small bowl, combine sugar and cocoa powder. Set aside. Place egg yolks in mixer bowl. Attach bowl and wire whip to mixer. Turn to Speed 2 and gradually add sugar mixture; mix about 30 seconds, or until well blended and slightly thickened. Continuing on Speed 2, very gradually add chocolate mixture and half-and-half; mix until well blended.

Return half-and-half mixture to medium saucepan; stirring constantly, cook over medium heat until small bubbles form around edge and mixture is steamy. Do not boil. Transfer half-and-half mixture into large bowl; stir in remaining 330 mL (1½ cups) whipping cream, vanilla, and salt. Cover and chill thoroughly, at least 8 hours.

Assemble and engage freeze bowl, dasher, and drive assembly as directed in attachment instructions. Turn to STIR Speed (Speed 1). Using a container with a spout, pour mixture into freeze bowl. Continue on STIR (Speed 1) for 10 to 15 minutes or until desired consistency, adding milk chocolate during last 1 to 2 minutes of freeze time. Immediately transfer ice cream into serving dishes, or freeze in an airtight container.

Yield: 16 servings (120 mL [½ cup] per serving).

# Caramel Pecan Ice Cream

---

- 850 mL (3½ cups)  
whole milk
- 1 can (415 mL [14 oz.])  
unsweetened  
condensed milk
- 230 mL (1 cup) prepared  
hot caramel or  
butterscotch caramel  
topping (about  
340 g [12 oz.])
- 1 package (100 g  
[3.4 oz.]) instant  
vanilla pudding
- 1 teaspoon vanilla  
A pinch of salt
- 50- 100 g coarsely  
chopped pecans

In medium bowl, place all ingredients except pecans. Whisk until well blended and pudding is dissolved. Cover and chill thoroughly, at least 6 hours.

Assemble and engage freeze bowl, dasher, and drive assembly as directed in attachment instructions. Turn to STIR Speed (Speed 1). Using container with spout, pour mixture into freeze bowl. Continue on STIR (Speed 1) for 15-20 minutes or until desired consistency, adding pecans during last 1 minute of freeze time. Immediately transfer ice cream into serving dishes, or freeze in an airtight container.

Yield: 16 servings (120 mL [½ cup] per serving).

English

# Gingerbread Ice Cream

---

- 150 g gingerbread, broken  
in small pieces
- 600 mL (2½ cups)  
whole milk
- 100 g sugar
- 1 tablespoon honey
- 6 egg yolks

In medium saucepan, heat over whole milk until very hot but not boiling, stirring often. Remove from heat and add small pieces of gingerbread.

Place egg yolks, honey and sugar in mixer bowl. Attach bowl and wire whip to mixer. Turn to speed 4 and mix about 30 seconds, or until well blended and slightly whitened.

Stirring constantly, cook the whole milk and gingerbread mixture until gingerbread melts. Gradually add the egg yolks, honey and sugar mixture. Do not boil. Remove from heat; set aside. Cover and chill thoroughly, at least 8 hours.

Assemble and engage freeze bowl, dasher, and drive assembly as directed in attachment instructions. Turn to STIR Speed (Speed 1). Using a container with a spout, pour mixture into freeze bowl. Continue on STIR (Speed 1) for 10 to 15 minutes or until desired consistency. Immediately transfer ice cream into serving dishes, or freeze in an airtight container.

Yield: 8 servings (120 mL [½ cup] per serving).

# Creamy Lemon-Orange Gelato

500 mL (2 cups) reduced-fat (2%) milk	Scald milk with orange peel, lemon peel and coffee beans in heavy medium saucepan.
4 (5 x 2 cm [2 x ¾-inch]) strips orange peel	Whisk yolks and sugar in medium bowl to blend. Gradually whisk half of milk mixture into yolks. Return yolks to saucepan with remaining milk. Stir over low heat until mixture thickens slightly and leaves path on back of spoon when finger is drawn across, about 8 minutes; do not boil. Strain into medium bowl. Refrigerate until well chilled.
4 (5 x 2 cm [2 x ¾-inch]) strips lemon peel	
6 coffee beans	
5 egg yolks	
170 g (¾ cup) sugar	

Assemble and engage freeze bowl, dasher, and drive assembly as directed in attachment instructions. Turn to Stir Speed. Using a container with a spout, pour mixture into freeze bowl. Continue on Stir Speed for 15 to 20 minutes or until desired consistency. Transfer ice cream to airtight container and freeze several hours to allow flavors to ripen. Can be prepared up to 4 days ahead. If frozen solid, soften slightly in refrigerator about 20 minutes before serving.

Yield: 8 servings (120 mL [½ cup] per serving).

# Fresh Raspberry Sorbet

750 g raspberries	Combine raspberries and water in bowl of food processor fitted with metal blade. Process until very smooth; pour through fine mesh strainer, pressing down lightly on solids trapped in strainer to extract as much liquid as possible without forcing solids through strainer. Discard solid. Pour liquid into airtight container and refrigerate until thoroughly chilled, at least 8 hours.
90 mL (¼ cup plus 2 tablespoons) water	
300 mL (1¼ cups) Simple Syrup (recipe follows)	

Assemble and engage freeze bowl, dasher, and drive assembly as directed in attachment instructions. Turn to STIR (Speed 1). Combine chilled raspberry juice and chilled simple syrup. Using a container with a spout, pour mixture into freeze bowl. Continue on STIR (Speed 1) for 7 to 12 minutes or until desired consistency. Immediately transfer sorbet into airtight container and freeze at least 2 hours before serving.

Yield: 8 servings (230 mL [1 cup] per serving).

## Simple Syrup

500 g (2 cups) sugar	Combine sugar and water in saucepan. Bring to a boil over medium-high heat; cook and stir until sugar dissolves completely, about 10 minutes. Transfer to ice bath, stirring until well chilled. Refrigerate until ready to use.
500 mL (2 cups) water	

Yield: 710 mL (3 cups) syrup

## Other Sorbets

Substitute the following quantities of ingredients for the ingredients listed on the previous page to make these sorbets:

Flavor	Fruit	Plus Water	Plus Simple Syrup
Lemon	475 mL (2 cups) lemon juice	none	300 mL (1¼ cups)
Mango	475 mL (2 cups) chopped	60 to 120 mL (¼ to ½ cup)	300 mL (1¼ cups)
Kiwi	475 mL (2 cups) chopped	135 mL (½ cup plus 1 tablespoon) (15 mL) lime juice	300 mL (1¼ cups)
Pineapple	475 mL (2 cups) chopped	75 mL (¼ cup plus 1 tablespoon) lime juice	300 mL (1¼ cups)
Blueberry	1.2 L (5 cups)	90 mL (¼ cup plus 2 tablespoons) lime juice	300 mL (1¼ cups)

## Minted Mango Sherbet

- 230 g (1 cup) sugar
- 700 mL (3 cups) whole milk
- 60 mL (¼ cup) cane sugar syrup
- 3 ripe mangoes, peeled, seeded, and chopped (about 700 mL [3 cups])
- 2 tablespoons fresh lime or lemon juice
- 2 teaspoons finely chopped fresh mint, if desired

In medium saucepan, combine sugar, milk, and corn syrup. Heat over medium heat, stirring often, until very hot but not boiling. Remove from heat; set aside.

Place mangoes and lime juice in food processor work bowl; use the multipurpose blade to process until smooth. Add mango mixture and mint to milk mixture. Cover and chill thoroughly, at least 8 hours.

Assemble and engage freeze bowl, dasher, and drive assembly as directed in attachment instructions. Turn to STIR Speed (Speed 1). Using a container with a spout, pour mixture into freeze bowl. Continue on STIR (Speed 1) for 7 to 12 minutes or until desired consistency. Immediately transfer sherbet into serving dishes, or freeze in an airtight container.

Yield: 14 servings (120 mL [½ cup] per serving).

# KitchenAid® Household Stand Mixer Attachment Warranty

Length of Warranty:	KitchenAid Will Pay For:	KitchenAid Will Not Pay For:
<p><b>Europe, Australia &amp; New Zealand:</b> Two Year Full Warranty from date of purchase.</p> <p><b>Other:</b> One Year Full Warranty from date of purchase.</p>	<p>Replacement parts and repair labor costs to correct defects in materials or workmanship. Service must be provided by an Authorized KitchenAid Service Center.</p>	<p>A. Repairs when Ice Cream Maker is used for operations other than normal household food preparation.</p> <p>B. Damage resulting from accident, alterations, misuse, abuse, or installation/operation not in accordance with local electrical codes.</p>

English

**KITCHENAID DOES NOT ASSUME ANY RESPONSIBILITY FOR INDIRECT DAMAGES.**

## Service Centers

All service should be handled locally by an Authorized KitchenAid Service Center. Contact the dealer from whom the unit was purchased to obtain the name of the nearest Authorized KitchenAid Service Center.

**In the U.K.:**  
Call: 0845 6011 287

**In Ireland:**  
M.X. ELECTRIC  
Service Department  
25 Alymer Crescent  
Kilcock, CO.KILDARE  
Call: 1 679 2398/87 2581574  
Fax: 1 628 4368

**In Australia:**  
Call: 1800 990 990

**In New Zealand:**  
Call: 0800 881 200

# Customer Service

---

**In U.K. & Ireland:** Tollfree number 00800 38104026

**Address:** KitchenAid Europa, Inc.  
PO BOX 19  
B-2018 ANTWERP 11  
BELGIUM

[www.KitchenAid.com](http://www.KitchenAid.com)

English



**FOR THE WAY IT'S MADE.®**

® Registered Trademark of KitchenAid, U.S.A.

™ Trademark of KitchenAid, U.S.A.

The shape of the stand mixer is a trademark of KitchenAid, U.S.A.

© 2006. All rights reserved.

Specifications subject to change without notice.