



LUNA CORNER MEDIUM SCONCE

CODE

AP1464

DIMENSIONS

2" w x 15" d x 21" h

WEIGHT

20lbs

ELECTRICAL

1 x LED STRIP 24V 3000K - 19w each - 19w total

1 x ± 1450lm each - ± 1450 lumens total

Dimmable by 1-10V

SHOWN IN

Frame: Bright Silver - FP/PB

Glass: Clear Glass #10

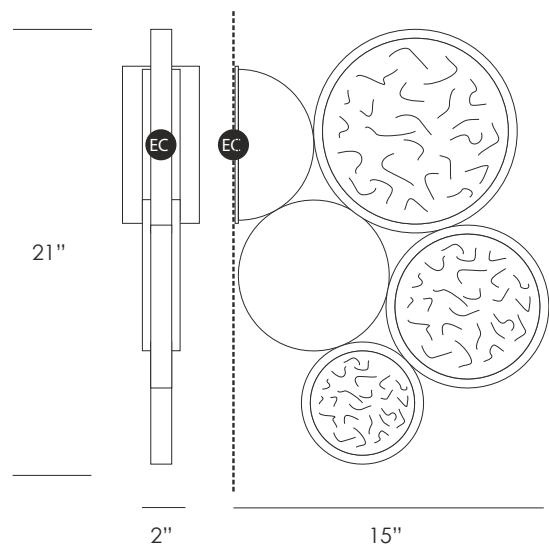

Glass Colors



10

10 - Clear

Metal Finishes



FO



FO/PB



FP



FP/PB



CO



CH



PL



PR



RO



TA

FO - Antique Gold (with Brown Patina)

FO/PB - Bright Gold (with White Patina)

FP - Antique Silver (Brown Patina Undercoat)

FP/PB - Bright Silver (White Patina Undercoat)

CO - Copper

CH - Lead

PL - Palladium

PR - Black

RO - Rose Gold

TA - Talha (Brown with randomly applied gold leaf and with a clear coat finish)

All the glass models are design by Serip, they are unique and exclusively handmade produced for them. For this reason, there is the possibility of variation in measures, weight colour and shape represented in this schematics, establishing a unique and prestigious feature of the glass handwork art.