

CHAPTER 14 LIFE AND PHYSICAL SCIENCES

AN INTRODUCTION TO BIOLOGY

This lesson introduces the basics of biology, including the process researchers use to study science. It also examines the classes of biomolecules and how substances are broken down for energy.

Biology and Taxonomy

The study or science of living things is called **biology**. Some characteristics, or traits, are common to all living things. These enable researchers to differentiate living things from nonliving things. Traits include reproduction, growth and development, **homeostasis**, and energy processing. Homeostasis is the body's ability to maintain a constant internal environment despite changes that occur in the external environment. With so many living things in the world, researchers developed a **taxonomy** system, which is used for classification, description, and naming. As shown below, there are seven classification levels in the classical Linnaean system.

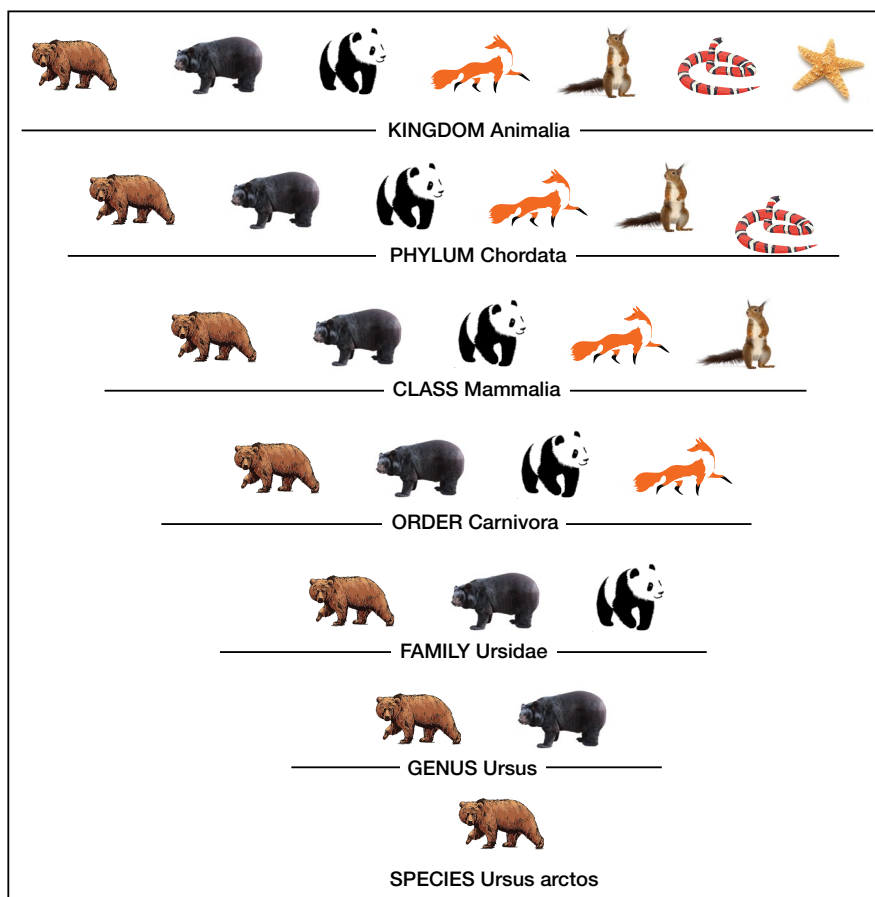

Specificity increases as the levels move from kingdom to species. For example, in the image the genus level contains two types of bears, but the species level shows one type. Additionally, organisms in each level are found in the level above it. For example, organisms in the order level are part of the class level. This classification system is based on physical similarities across living things. It does not account for molecular or genetic similarities.

DID YOU KNOW?

Carl Linnaeus only used physical similarities across organisms when he created the Linnaean system because technology was not advanced enough to observe similarities at the molecular level.

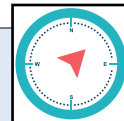

Example

A researcher classifies a newly discovered organism in the class taxonomy level. What other taxonomic level is this new organism classified in?

- A. Order B. Family C. Species D. Kingdom

The correct answer is D. Each level is found in the level above it. The levels above class are phylum and kingdom.

Scientific Method

To develop the taxonomic system, researchers had to ask questions. Researchers use seven steps to answer science questions or solve problems. These make up the **scientific method**, described below:

1. **Problem:** The question created because of an observation. *Example: Does the size of a plastic object affect how fast it naturally degrades in a lake?*
2. **Research:** Reliable information available about what is observed. *Example: Learn how plastics are made and understand the properties of a lake.*
3. **Hypothesis:** A predicted solution to the question or problem. *Example: If the plastic material is small, then it will degrade faster than a large particle.*
4. **Experiment:** A series of tests used to evaluate the hypothesis. Experiments consist of an **independent variable** that the researcher modifies and a **dependent variable** that changes due to the independent variable. They also include a **control group** used as a standard to make comparisons. *Example: Collect plastic particles both onshore and offshore of the lake over time. Determine the size of the particles and describe the lake conditions during this time period.*
5. **Observe:** Analyze data collected during an experiment to observe patterns. *Example: Analyze the differences between the numbers of particles collected in terms of size.*
6. **Conclusion:** State whether the hypothesis is rejected or accepted and summarize all results.
7. **Communicate:** Report findings so others can replicate and verify the results.

Sometimes, just a few steps of the scientific method are necessary to research a question. At other times, several steps may be repeated as needed. The goal of this method is to find a reliable answer to the scientific question.

TEST TIP

Using the first letter in each of the steps, you can create a mnemonic device to remember the steps. For example: “**P**eople **R**eally **H**ave **E**lephants **O**n **C**ompact **C**ars.” Try creating your own mnemonic device!



Over the course of many years during which scientists are able to collect sufficient and reliable data, the scientific method can be used to create a law or theory. A **law** is a rule that describes patterns observed in nature. A **scientific theory** explains the how and why of things that happens in nature through observations and experiments. Scientists widely accept both laws and theories, but they can be modified over time.

Example

In a study, a researcher describes what happens to a plant following exposure to a dry and hot environment. What step of the scientific method does this most likely describe?

- | | |
|--------------------------|-------------------------------|
| A. Forming a hypothesis | C. Communicating findings |
| B. Making an observation | D. Characterizing the problem |

The correct answer is **B**. The researcher is collecting qualitative data by describing what happens to the plant under specific conditions. This data collection corresponds to the observation step of the scientific method.

Water and Biomolecule Basics

From oceans and streams to a bottle, water is fundamental for life. Without water, life would not exist. Because of water’s unique properties, it plays a specific role in living things. The molecular structure of water consists of an oxygen atom bonded to two hydrogen atoms. The structure of water explains some of its properties. For example, water is polar. The oxygen atom is slightly negatively charged, while both hydrogen atoms are slightly positively charged.

As shown below, a single water molecule forms **hydrogen bonds** with nearby water molecules. This type of bonding creates a weak attraction between the water molecules. Hydrogen bonding contributes to water’s high boiling point. Water is necessary for biochemical processes like photosynthesis and cellular respiration. It is also a universal solvent, which means water dissolves many different substances.

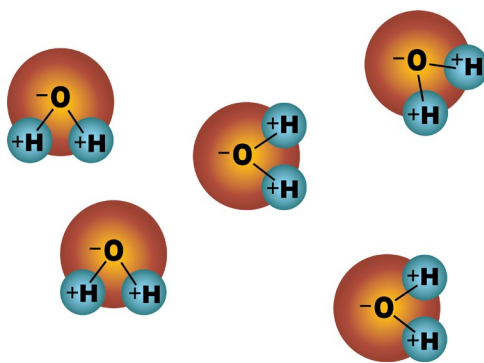

Only two water molecules are needed to show bonding. Remove the partial negative/positive signs and put a - sign next to the oxygen atom and a + sign next to each hydrogen (H) atom. Remove the solid lines between the H and O but keep the dashed line connecting one water molecule to the next.

KEEP IN MIND

It takes a lot of heat to create hot water. This is because of water's high specific heat capacity, which is the amount of heat required to raise the temperature of 1 kilogram of water by 1 degree Celsius. This property of water also makes it ideal for living things.

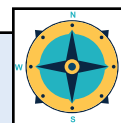

Biomolecules, or biological molecules, are found in living things. These organic molecules vary in structure and size and perform different functions. Researchers group the wide variety of molecules found in living things into four major classes for organizational purposes: proteins, carbohydrates, lipids, and nucleic acids. Each class of biomolecules has unique **monomers** and **polymers**. Monomers are molecules that covalently bond to form larger molecules or polymers. The table below lists characteristics of each class.

Biomolecule	Monomer(s)	Function	Example
Protein	Amino acid	A substance that provides the overall basic structure and function for a cell	Enzymes
Carbohydrate	Monosaccharides	A form of storage for energy	Glucose Cellulose Starch Disaccharides
Lipid	Glycerol and fatty acids	A type of fat that provides a long-term storage for energy	Fats Steroids Oils Hormones
Nucleic acid	Nucleotides	A substance that aids in protein synthesis and transmission of genetic information	DNA RNA

Example

During protein synthesis in a cell, the primary structure of the protein consists of a linear chain of monomers. What is another way to describe this structure?

- A. A linear chain of fatty acids that are hydrogen-bonded together
- B. A linear chain of nucleotides that are hydrogen-bonded together
- C. A linear chain of amino acids that are covalently bonded together
- D. A linear chain of monosaccharides that are covalently bonded together

The correct answer is C. The monomers of proteins include amino acids, which are covalently bonded together to form a protein.

The Metabolic Process

Just like water, energy is essential to life. Food and sunlight are major energy sources. Metabolism is the process of converting food into usable energy. This refers to all biochemical processes or reactions that take place in a living thing to keep it alive.

CONNECTIONS

Energy flows through living things. Energy from the sun is converted to chemical energy via photosynthesis. When living things feed on plants, they obtain this energy for survival.



A metabolic pathway is a series of several chemical reactions that take place cyclically to either build or break down molecules. An **anabolic pathway** involves the synthesis of new molecules. These pathways require an input of energy. **Catabolic pathways** involve the breakdown of molecules. Energy is released from a catabolic pathway.

Living things use several metabolic pathways. The most well-studied pathways include glycolysis, the citric acid cycle, and the electron transport chain. These metabolic pathways either release or add energy during a reaction. They also provide a continual flow of energy to living things.

1. **Glycolysis:** This is a catabolic pathway that uses several steps to break down glucose sugar for energy, carbon dioxide, and water. Energy that is released from this reaction is stored in the form of adenosine triphosphate (ATP). Two ATP molecules, two pyruvate molecules, and two NADH molecules are formed during this metabolic pathway.

BE CAREFUL!

Some of these metabolic pathways produce energy in different parts of the cell. Glycolysis takes place in the cytoplasm of the cell. But the citric acid cycle and oxidative phosphorylation occur in the mitochondria.



- 2. Citric acid cycle:** The pyruvate molecules made from glycolysis are transported inside the cell's mitochondria. In this catabolic pathway, pyruvate is used to make two ATP molecules, six carbon dioxide molecules, and six NADH molecules.
- 3. Electron transport chain and oxidative phosphorylation:** This also takes place in the cell's mitochondria. Many electrons are transferred from one molecule to another in this chain. At the end of the chain, oxygen picks up the electrons to produce roughly 34 molecules of ATP.

The following image provides an overview of **cellular respiration**. Glycolysis, the citric acid cycle, the electron transport chain, and oxidative phosphorylation collectively make up this process. Cellular respiration takes place in a cell and is used to convert energy from nutrients into ATP.

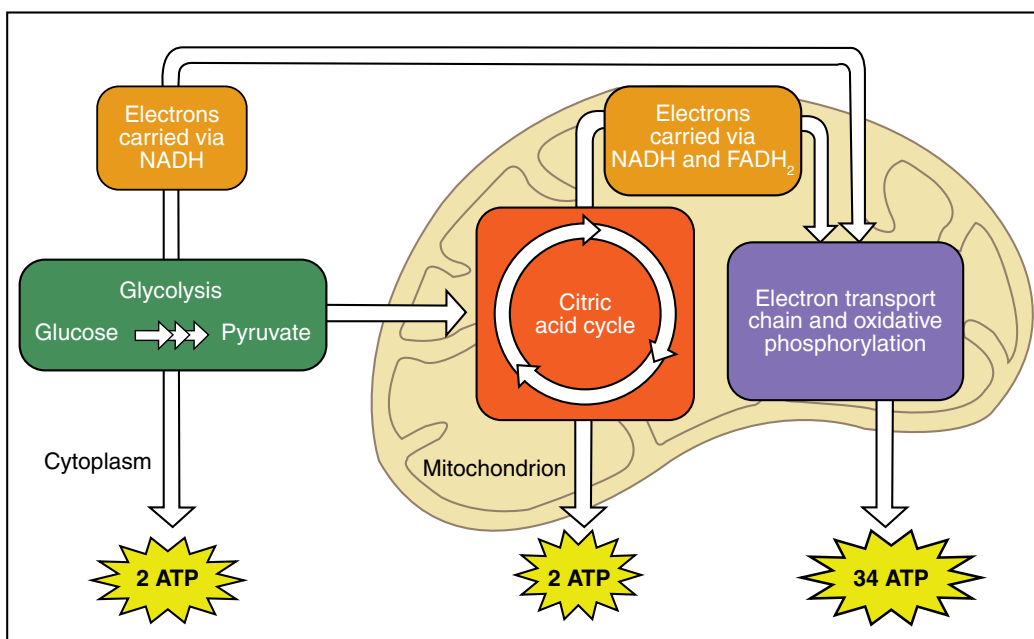

Example

Why are metabolic pathways cyclic?

- Metabolic reactions generally take place one at a time.
- All of the products created in metabolic reactions are used up.
- The reactions are continuous as long as reactants are available.
- Energy in the form of ATP is sent to different cells for various uses.

The correct answer is C. Metabolic reactions are cyclic, which means they keep occurring as long as enough starting materials are available to allow the reaction to proceed.

Let's Review!

- This lesson explored how living things are organized, what the scientific method is, and how biomolecules are classified. It also discussed how living things obtain energy via metabolism.
- Biology is the study of living things. Several characteristics distinguish living things from nonliving things.
- All living things are described, classified, and named using a taxonomic system.
- The scientific method uses seven steps to answer a question or solve a problem.
- Biomolecules are organic molecules that are organized into four classes: proteins, carbohydrates, lipids, and nucleic acids
- Living things rely on various metabolic pathways to produce energy and store it in the form of ATP.

CELL STRUCTURE, FUNCTION, AND TYPE

This lesson describes the cell structure and two different types of cells. The lesson also explores the functions of various cell parts.

Cell Theory and Types

All living things are made of cells. **Cells** are the smallest structural units and basic building blocks of living things. Cells contain everything necessary to keep living things alive. Varying in size and shape, cells carry out specialized functions. Robert Hooke discovered the first cells in the mid-eighteenth century. Many years later, after advancements in microscopy, the cell theory was formed. This theory, or in-depth explanation, about cells consists of three parts:

1. All living things are composed of one or more cells.
2. Cells are alive and represent the basic unit of life.
3. All cells are produced from preexisting cells.

DID YOU KNOW?

More than a trillion cells and at least 200 different types of cells exist in the human body!

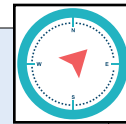

Many different types of cells exist. Because of this, cells are classified into two general types: prokaryotic cells and eukaryotic cells. The following comparison table lists key differences between prokaryotes and eukaryotes:

Characteristic	Prokaryote	Eukaryote
Cell size	Around 0.2–2.0 mm in diameter	Around 10–100 mm in diameter
Nucleus	Absent	True nucleus
Organelles	Absent	Several present, ranging from ribosomes to the endoplasmic reticulum
Flagella	Simple in structure	Complex in structure

As shown in the image, prokaryotic cells lack nuclei. Their DNA floats in the **cytoplasm**, which is surrounded by a **plasma membrane**. Very simplistic in structure, these cells lack organelles but do have cell walls. **Organelles** are specialized structures with a specific cellular function. They also may have **ribosomes** that aid in protein synthesis. Also, these cells have a **flagellum** that looks like a tail attached to the cell. Flagella aid in locomotion. The **pili**, or hair-like structures surrounding the cells, aid in cellular adhesion. Bacteria and Archaea are the most common prokaryotes. Most prokaryotes are **unicellular**, or made of a single cell, but there are a few **multicellular organisms**.

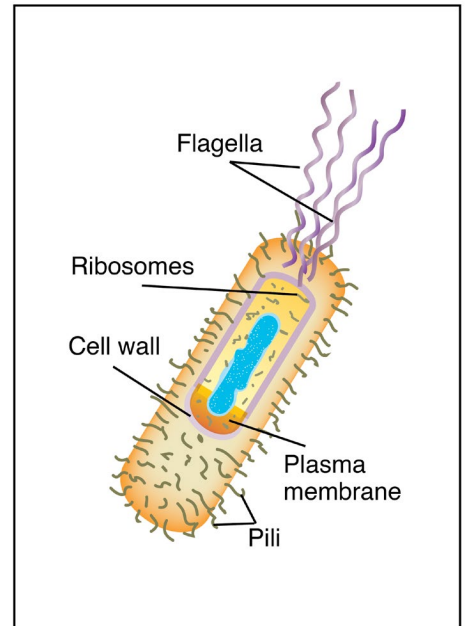

Eukaryotic cells contain a membrane-bound nucleus where DNA is stored. Membrane-bound organelles also exist in eukaryotic cells. Similar to prokaryotic cells, eukaryotic cells have cytoplasm, ribosomes, and a plasma membrane. Eukaryotic organisms can be either unicellular or multicellular. Much larger than prokaryotes, examples of eukaryotic organisms include fungi and even people.

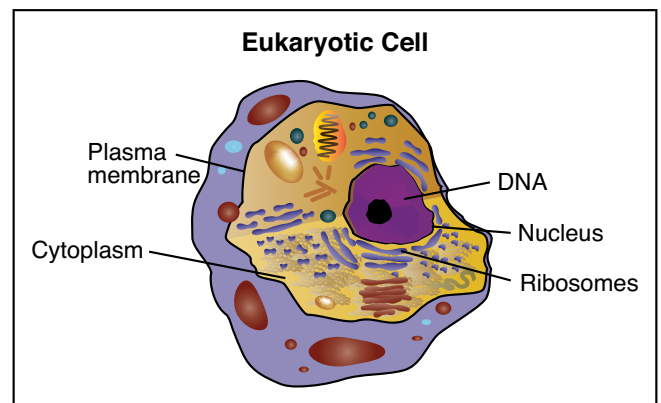

Example

What is an organelle?

- A. The building block of all living things
- B. A substance that is able diffuse inside a cell
- C. The specific receptor found on a cell's surface
- D. A membrane-bound structure with a special function

The correct answer is **D**. Organelles such as ribosomes and the nucleus are membrane-bound structures that have specific functions in a cell.

A Peek Inside the Animal Cell

Animal cells are eukaryotic cells. Cheek, nerve, and muscle cells are all examples of animal cells. Because there are many different types, each animal cell has a specialized function. But all animal cells have the same parts, or organelles. Use this image as a guide while going through following list, which describes the organelles found in a eukaryotic (or animal) cell.

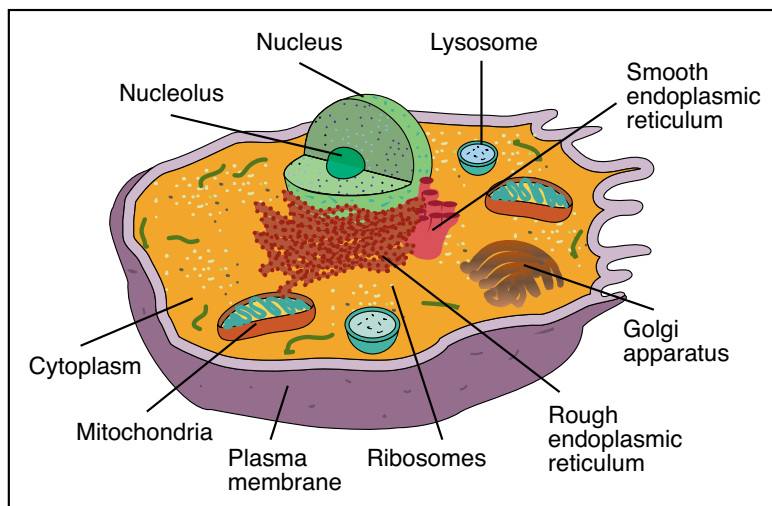

- **Cell membrane:** A double layer that separates the inside of the cell from the outside environment. It is semi-permeable, meaning it only allows certain molecules to enter the cell.
- **Nucleus:** A membrane-bound organelle that contains the genetic material, such as DNA, for a cell. Inside the nucleus is the **nucleolus** that plays a role in assembling subunits required to make ribosomes.
- **Mitochondria:** The cell's powerhouses that provide energy to the cell for it to function. Much of the energy in the form of ATP is produced here.
- **Ribosomes:** The cell's protein factories that can be found floating in the cytoplasm or attached to the endoplasmic reticulum.
- **Vacuoles:** Small sacs in a cell that store water and food for survival. This organelle also stores waste material that is mostly in the form of water.
- **Endoplasmic reticulum:** A network of membranes that functions as a cell's transportation system, shuttling proteins and other materials around the cell. The **smooth endoplasmic reticulum** lacks ribosomes, and the **rough endoplasmic reticulum** has ribosomes.
- **Lysosomes:** Sac-like structures that contain digestive enzymes that are used to break down food and old organelles.
- **Golgi apparatus:** A stack of flattened pouches that plays a role in processing proteins received from the endoplasmic reticulum. It modifies proteins from the endoplasmic reticulum and then packages them into a vesicle that can be sent to other places in the cell.

KEEP IN MIND!

Some of the organelles in animal cells are also present in plant cells. In addition, all organelles are found in the cytoplasm of the cell. The only exception is the nucleus, which it is separated from the cytoplasm because it has its own membrane.

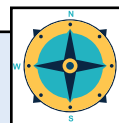

Example

Which two organelles work together to facilitate protein synthesis?

- A. Cytoplasm and lysosome
- B. Vacuole and mitochondria
- C. Nucleus and cell membrane
- D. Ribosome and endoplasmic reticulum

The correct answer is **D**. After a protein is synthesized by ribosomes, it is shuttled to the endoplasmic reticulum, where it is further modified and prepared to be transported by vesicles to other places in the cell.

Plant Cells

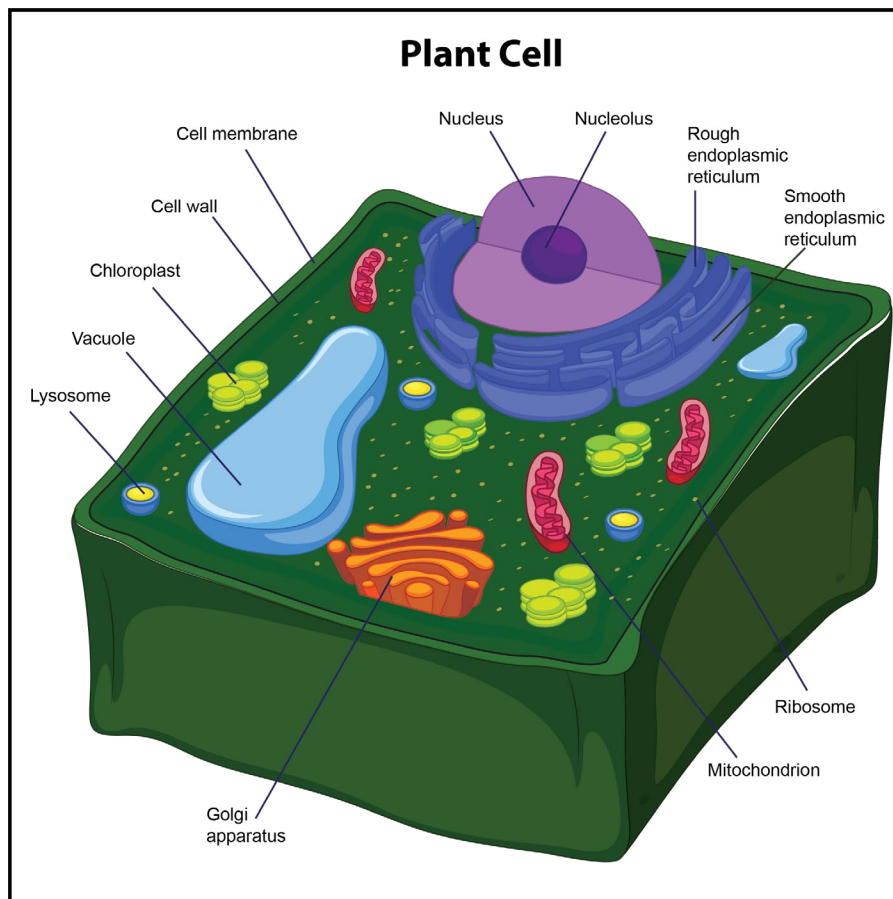

Recall that plant cells are also eukaryotic cells. Structurally, these cells are similar to animal cells because some of the parts in a plant cell are also found in an animal cell. However, there are some notable differences. The following image shows the structure of a plant cell.

First, only plant cells have a **cell wall**. The purpose of this structure is to provide protection and support to plant cells. The cell wall also enforces the overall structural integrity of the plant cell, and it is found outside the cell membrane. The next organelle is a chloroplast. It is found in the cytoplasm of only plant cells. **Chloroplasts** are photosynthetic compounds used

to make food for plant cells by harnessing energy from the sun. These organelles play a role in photosynthesis.

Chloroplasts and mitochondria are both designed to collect, process, and store energy for the cell. Thus, organisms are divided into autotrophs or heterotrophs based on how they obtain energy. **Autotrophs** are organisms that make energy-rich biomolecules from raw material in nature. They do this by using basic energy sources such as the sun. This explains why most autotrophs rely on photosynthesis to transform sunlight into usable food that can produce energy necessary for life. Plants and certain species of bacteria are autotrophs.

Animals are **heterotrophs** because they are unable to make their own food. Heterotrophs have to consume and metabolize their food sources to absorb the stored energy. Examples of heterotrophs include all animals and fungi, as well as certain species of bacteria.

DID YOU KNOW?

More than 99% of all energy for life on Earth is provided through the process of photosynthesis.

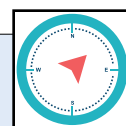

Example

Kelp use chlorophyll to capture sunlight for food. What are these organisms classified as?

- A. Autotrophs B. Chemotrophs C. Heterotrophs D. Lithotrophs

The correct answer is A. Kelp is an autotroph because it uses chlorophyll to trap energy from the sun to make food.

Let's Review!

- This lesson focused on the cell theory, different cell types, and the various cell parts found in plant and animal cells.
- The cell theory is an in-depth explanation, supported with scientific data, to prove a cell is a living thing and has unique characteristics.
- Cells are the basic building blocks of life. Coming in various sizes and shapes, cells have specialized functions.
- Two broad types of cells are prokaryotic and eukaryotic cells.
- Prokaryotes are single-celled organisms that lack a nucleus, while eukaryotes are multicellular organisms that contain a nucleus.
- Chloroplasts and cell walls are only found in plant cells.
- Both animal and plant cells have similar organelles such as ribosomes, mitochondria, and an endoplasmic reticulum.
- Living things can be classified as autotrophs or heterotrophs based on how they obtain energy.

CELLULAR REPRODUCTION, CELLULAR RESPIRATION, AND PHOTOSYNTHESIS

This lesson introduces basic processes including cellular reproduction and division, cellular respiration, and photosynthesis. These processes provide ways for cells to make new cells and to convert energy to and from food sources.

Cell Reproduction

Cells divide primarily for growth, repair, and reproduction. When an organism grows, it normally needs more cells. If damage occurs, more cells must appear to repair the damage and replace any dead cells. During reproduction, this process allows all living things to produce offspring. There are two ways that living things reproduce: asexually and sexually.

Asexual reproduction is a process in which only one organism is needed to reproduce itself. A single parent is involved in this type of reproduction, which means all offspring are genetically identical to one another and to the parent. All prokaryotes reproduce this way. Some eukaryotes also reproduce asexually. There are several methods of asexual reproduction.

Binary fission is one method. During this process, a prokaryotic cell, such as a bacterium, copies its DNA and splits in half. Binary fission is simple because only one parent cell divides into two daughter cells (or offspring) that are the same size.

Sexual reproduction is a process in which two organisms produce offspring that have genetic characteristics from both parents. It provides greater genetic diversity within a population than asexual reproduction. Sexual reproduction results in the production of **gametes**. These are reproductive cells. Gametes unite to create offspring.

Example

Binary fission is a method

- A. where one daughter cell is produced.
- B. required to produce reproductive cells.
- C. that represents a form of asexual reproduction.
- D. where two parent cells interact with each other.

The correct answer is C. Binary fission is a method organisms use to reproduce asexually. It involves a single parent cell that splits to create two identical daughter cells.

When the Cell Cycle Begins

For a cell to divide into more cells, it must grow, copy its DNA, and produce new daughter cells. The **cell cycle** regulates cellular division. This process can either prevent a cell from dividing or trigger it to start dividing.

The cell cycle is an organized process divided into two phases: **interphase** and the **M (mitotic)**

phase. During interphase, the cell grows and copies its DNA. After the cell reaches the M phase, division and of the two new cells can occur. The G_1 , S, and G_2 phases make up interphase.

- **G₁**: The first gap phase, during which the cell prepares to copy its DNA
- **S**: The synthesis phase, during which DNA is copied
- **G₂**: The second gap phase, during which the cell prepares for cell division

It may appear that little is happening in the cell during the gap phases. Most of the activity occurs at the level of enzymes and macromolecules. The cell produces things like nucleotides for synthesizing new DNA strands, enzymes for copying the DNA, and tubulin proteins for building the mitotic spindle. During the S phase, the DNA in the cell doubles, but few other signs are obvious under the microscope. All the dramatic events that can be seen under a microscope occur during the M phase: the chromosomes move, and the cell splits into two new cells with identical nuclei.

Example

For an organism, the cell cycle is needed for

- A. competition. B. dispersal. C. growth. D. parasitism.

The correct answer is **C**. The cell cycle is the process during which a cell grows, copies its own DNA, and physically separates into new cells. With help from the cell cycle, more cells can be provided to help an organism grow.

Mitosis

Mitosis is a form of cell division where two identical nuclei are produced from one nucleus. DNA contains the genetic information of the cell. It is stored in the nucleus. During mitosis, DNA in the nucleus must be copied, or replicated. Recall that this happens during the S phase of the cell cycle. During the M phase, this copied DNA is divided into two complete sets, one of which goes to a daughter cell.

KEEP IN MIND

The cell cycle is a circular process. This means after two daughter cells are made, they can participate in the cell cycle process, starting it over from the beginning.

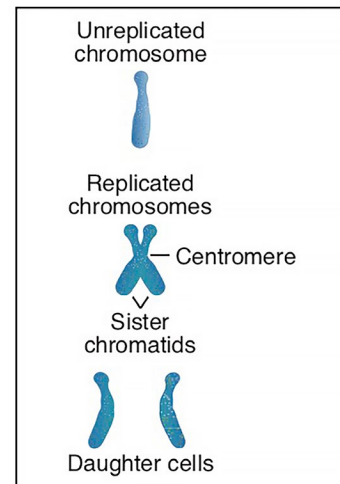
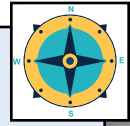

When DNA replicates, it condenses to form **chromosomes** that resemble an X. The DNA forms chromosomes by wrapping around proteins called histones. As shown below, it takes two identical sister chromatids to form a chromosome. A **centromere** holds the sister chromatids together.

Four phases take place during mitosis to form two identical daughter cells:

- 1. Prophase:** The nuclear membrane disappears, and other organelles move out of the way. The spindle, made of microtubules, begins to form. During **prometaphase**, the microtubules begin to attach to the centromeres at the center of the chromosome.
- 2. Metaphase:** Spindle fibers line the chromosomes at the center of the cell. This is because they are pulled equally by the spindle fibers, which are attached to the opposite poles of the cell.
- 3. Anaphase:** The chromosomes are pulled to the opposite poles of the cell.
- 4. Telophase:** The chromosomes de-condense, the nuclear membrane reappears, and other parts of the cell return to their usual places in the cell.

The cell divides into two daughter cells by way of **cytokinesis**. The illustration below demonstrates the process of mitosis.

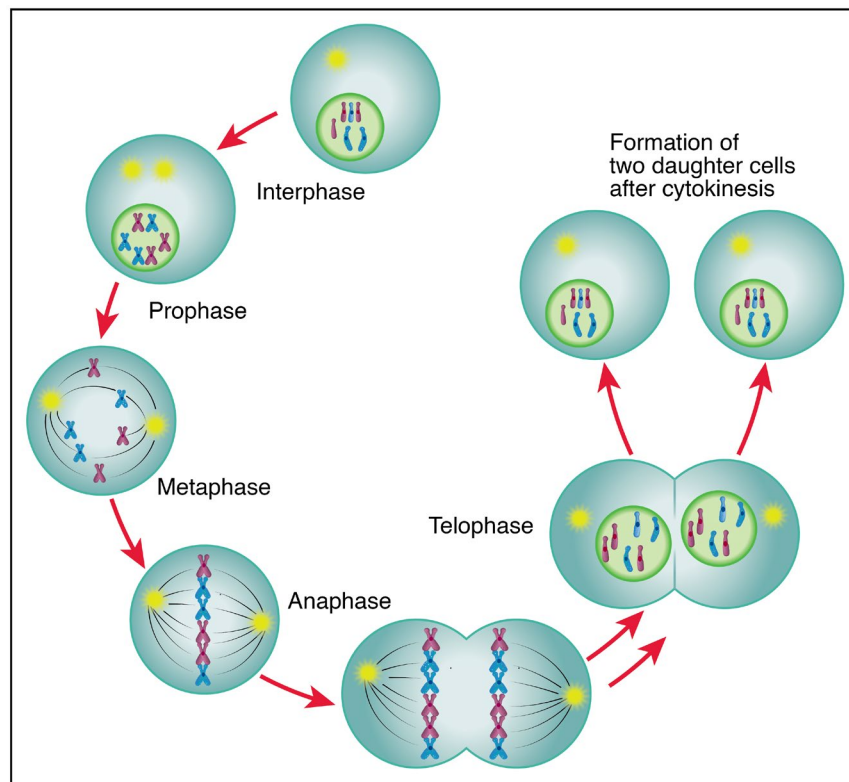

**TEST TIP**

There is a popular mnemonic to help remember the order of the phases for mitosis:

[Please] Pee on the MAT.

The “please” refers to prophase, while “pee” refers to prometaphase. MAT stands for metaphase, anaphase, and telophase, respectively.

Example

Before mitosis occurs

1. the spindle fibers must elongate.
2. DNA must wrap around histones.
3. chromosomes must split into chromatids.
4. the cell cycle process must be suspended.

The correct answer is **B**. After DNA replicates, it wraps around proteins called histones to form a chromosome. The chromosome must be formed for mitosis to occur.

Meiosis

Meiosis, sexual cell division in eukaryotes, involves two phases of mitosis that take place one after the other but without a second replication of DNA. This provides the reduction in chromosome number from $2n$ to n needed for fertilization to restore the normal $2n$ state. Diploid multicellular organisms use meiosis, which reduces the number of chromosomes by half. Then, when two haploid (n) sex cells (sperm, egg) unite, the normal number of chromosomes is restored. Diploid organisms, such as humans and oak trees, have two copies of every chromosome per cell ($2n$), as opposed to n , when one copy of every chromosome is present per cell.

DID YOU KNOW?

During prophase I of meiosis, **crossing over** occurs to increase genetic diversity. Corresponding chromosomes from the mother and the father of the organism undergoing meiosis are physically bound, and X-shaped structures called **chiasmata** form. These are where corresponding DNA from the different parental chromosomes are exchanged, resulting in increased diversity.

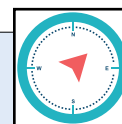

The process of meiosis is divided into two rounds of cell division: meiosis I and meiosis II. The phases that occur in mitosis (prophase, metaphase, anaphase, and telophase) also occur during each round of meiosis. Also, cytokinesis occurs after telophase during each round of cell division. However, DNA replication does not happen when meiosis I proceeds to meiosis II. The result of meiosis is one diploid cell that divides into four haploid cells, as shown in the following image.

Glycolysis takes place in the cell's cytoplasm. End product yield from this reaction per one glucose molecule is

- two molecules of ATP
- two molecules of pyruvate
- two molecules of NADH

2. Oxidation of pyruvate: Pyruvate is converted into **acetyl coA** in the mitochondrial matrix. This transition reaction must happen for pyruvate to enter the next phase of cellular respiration. Pyruvate is **oxidized**, which means it loses two electrons and a hydrogen molecule. This results in the formation of NADH and loss of CO_2 .

DID YOU KNOW?

The citric acid cycle is not identical for all organisms. Plants have some differences in terms of the enzymes used and energy carriers produced.

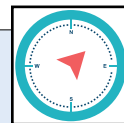

3. Citric acid cycle: Also called the **Krebs cycle**, during this cycle an acetyl group detaches from the coenzyme A in the acetyl coA molecule. This process is **aerobic**, which means it must occur in the presence of oxygen. The net yield per one glucose molecule is

- two molecules of ATP
- six molecules of NADH
- two molecules of FADH_2
- four molecules of CO_2

4. Electron transport chain: This process happens in the inner mitochondrial membrane. It consists of a series of enzymatic reactions. Both NADH and FADH_2 molecules are passed through a series of enzymes so that electrons and protons can be released from them. During this process, energy is released and used to fuel **chemiosmosis**. During chemiosmosis, protons are transported across the inner mitochondrial membrane to the outer mitochondrial compartment. This flow of protons drives the process of ATP synthesis. This step of cellular respiration creates an approximate net yield of 34 ATP per glucose molecule. Six molecules of water are also formed at the end of the electron transport chain.

KEEP IN MIND

Cellular respiration requires oxygen, but there are forms of **fermentation** that extract energy from food without using oxygen. Fermentation can be either alcoholic (makes ethanol as an end product, like yeast in the brewing of beer) or lactic acid type. Lactic acid is produced in a person's muscles during strenuous activity when the body cannot move enough oxygen to the cells.

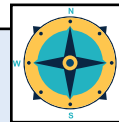

Example

Before a molecule of glucose can be run through the citric acid cycle, it must experience

- A. ATP production.
- B. NADH production.
- C. pyruvate oxidation.
- D. oxygen deprivation.

The correct answer is C. A glucose molecule must first experience pyruvate oxidation because one CO_2 molecule must be removed from each pyruvate molecule after glycolysis and before the citric acid cycle.

Photosynthesis

Photosynthesis is the process plants use to make a food source from energy. This process can be thought of as the reverse of cellular respiration. Instead of glucose being broken down into carbon dioxide to create energy-containing molecules, energy is captured from the sun and used to turn carbon dioxide into glucose (and other organic chemicals the plant needs). The energy source is the sun. The reaction for photosynthesis is shown below:

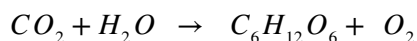

Energy is captured from the sun and used to turn carbon dioxide into glucose (and other organic chemicals). **Chloroplasts** are **organelles** in plants that contain green chlorophyll, which helps the plants absorb light from the sun.

The photosynthetic reaction involves two distinct phases: light reactions and dark reactions. Light-dependent reactions require light to produce ATP and NADPH. During dark reactions, also known as the **Calvin cycle**, light is not required. These reactions use ATP and NADPH to produce sugar molecules like glucose.

DID YOU KNOW?

Some plants skip photosynthesis! These plants are parasites. They lack chlorophyll, so they attach to nearby plants, stealing water and sugar from their hosts.

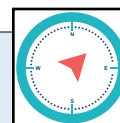

Let's Review!

- Cells are needed for growth, repair, and reproduction.
- Mitosis is a form of cell division where one parent cell divides into identical two daughter cells.
- Meiosis involves two rounds of cell division to divide two parent cells into four haploid cells.
- Cells are powered by cellular respiration and photosynthesis, which make ATP and organic chemicals.
- Cellular respiration goes from glycolysis to the citric acid cycle to the electron transport chain.
- Photosynthesis proceeds from the light reactions to the dark reactions, which are known as the Calvin cycle.

GENETICS AND DNA

The lesson introduces genetics, which is the study of heredity. Heredity is the characteristics offspring inherit from their parents. This lesson also examines Gregor Mendel's theories of heredity and how they have affected the field of genetics.

Gregor Mendel and Garden Peas

From experiments with garden peas, Mendel developed a simple set of rules that accurately predicted patterns of heredity. He discovered that plants either **self-pollinate** or **cross-pollinate**, when the pollen from one plant fertilizes the pistil of another plant. He also discovered that traits are either **dominant** or **recessive**. Dominant traits are expressed, and recessive traits are hidden.

Mendel's Theory of Heredity

To explain his results, Mendel proposed a theory that has become the foundation of the science of genetics. The theory has five elements:

1. Parents do not transmit traits directly to their offspring. Rather, they pass on units of information called **genes**.
2. For each trait, an individual has two factors: one from each parent. If the two factors have the same information, the individual is **homozygous** for that trait. If the two factors are different, the individual is **heterozygous** for that trait. Each copy of a factor, or **gene**, is called an **allele**.
3. The alleles determine the physical appearance, or **phenotype**. The set of alleles an individual has is its **genotype**.
4. An individual receives one allele from each parent.
5. The presence of an allele does not guarantee that the trait will be expressed.

Punnett Squares

Biologists can predict the probable outcomes of a cross by using a diagram called a **Punnett square**. In the Punnett square illustrated at the right, the yellow pea pods are dominant, as designated by a capital Y, and the green pea pods are recessive, as designated with a lowercase y. In a cross between one homozygous recessive (yy) parent and a heterozygous dominant parent (Yy), the outcome is two heterozygous dominant offspring (Yy) and two homozygous recessive offspring (yy), which gives a ratio of 2:2.

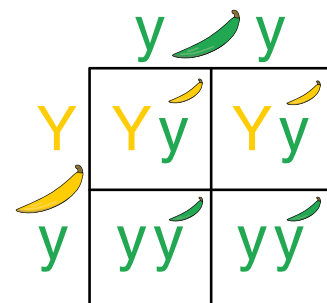

Example

In the Punnett square below, homozygous green pea pods are crossed with dominant yellow pea pods. What is the probability of a homozygous green pea pod?

- A. 25% C. 75%
 B. 50% D. 100%

The correct answer is **B**. There is a 2 out of 4, or 50%, chance of a homozygous green pea pod.

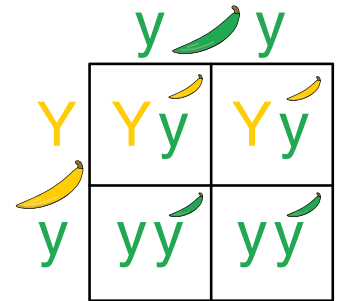

Chromosomes

A **gene** is a segment of DNA, deoxyribonucleic acid, which transmits information from parent to offspring. A single molecule of DNA has thousands of genes. A **chromosome** is a rod-shaped structure that forms when a single DNA molecule and its associated proteins coil tightly before cell division.

Chromosomes have two components:

- **Chromatids:** two copies of each chromosome
- **Centromeres:** protein discs that attach the chromatids together

Human cells have 23 sets of different chromosomes. The two copies of each chromosome are called **homologous** chromosomes, or homologues. An offspring receives one homologue from each parent. When a cell contains two homologues of each chromosome, it is termed **diploid (2n)**. A **haploid (n)** cell contains only one homologue of each chromosome. The only haploid cells humans are the sperm and eggs cells known as **gametes**.

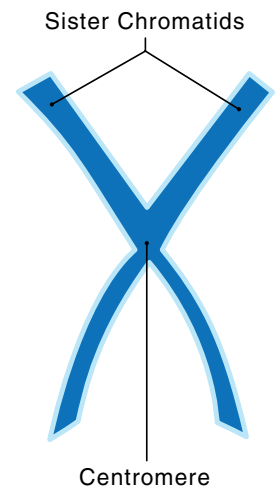

Example

What is the difference between a diploid cell and a haploid cell?

- A. A haploid cell is only found in skin cells.
 B. A diploid cell is only found in heart cells.
 C. A diploid cell has a full number of chromosomes, and a haploid cell does not.
 D. A haploid cell has a full number of chromosomes, and a diploid cell does not.

The correct answer is **C**. Diploid cells have a full number of chromosomes, and haploid cells have half the number of chromosomes.

Deoxyribonucleic Acid

The DNA molecule is a long, thin molecule made of subunits called **nucleotides** that are linked together in a **nucleic acid** chain. Each nucleotide is constructed of three parts: a **phosphate group**, **five-carbon sugar**, and **nitrogen base**.

The four nitrogenous bases are

- adenine (A);
- guanine (G);
- thymine (T); and
- cytosine (C).

Adenine and guanine belong to a class of large, organic molecules called **purines**. Thymine and cytosine are **pyrimidines**, which have a single ring of carbon and nitrogen atoms. Base pairs are formed as adenine pairs with thymine and guanine pairs with cytosine. These are the only possible combinations.

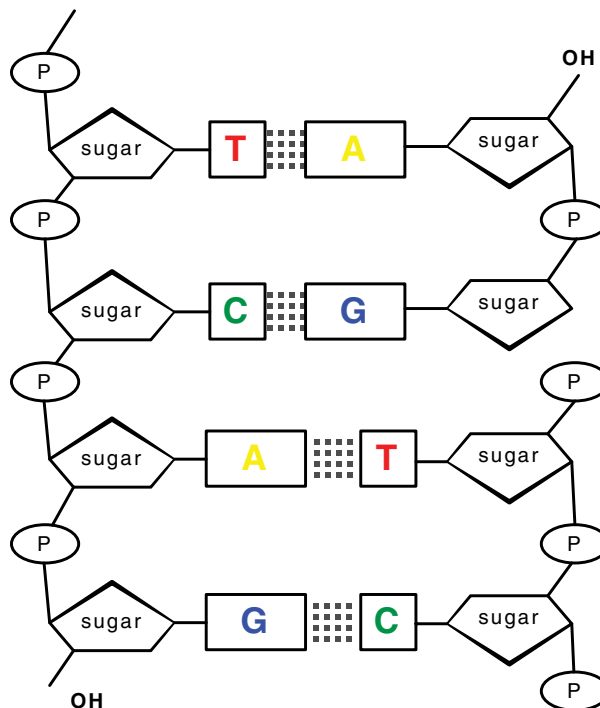

DNA Replication

The process of synthesizing a new strand of DNA is called **replication**. A DNA molecule replicates by separating into two strands, building a complementary strand, and twisting to form a double helix.

Transcription

The first step in using DNA to direct the making of a protein is **transcription**, the process that “rewrites” the information in a gene in DNA into a molecule of messenger RNA. Transcription manufactures three types of RNA:

- Messenger RNA (mRNA)
- Transfer RNA (tRNA)
- Ribosomal RNA (rRNA)

Messenger RNA is an RNA copy of a gene used as a blueprint for a protein. In eukaryotes, transcription does not produce mRNA directly; it produces a pre-mRNA molecule. **Transfer RNA** translates mRNA sequences into amino acid sequences. **Ribosomal RNA** plays a structural role in ribosomes.

Transcription proceeds at a rate of about 60 nucleotides per second until the **RNA polymerase** (an enzyme) reaches a **stop codon** on the DNA called a **terminator** and releases the RNA molecule.

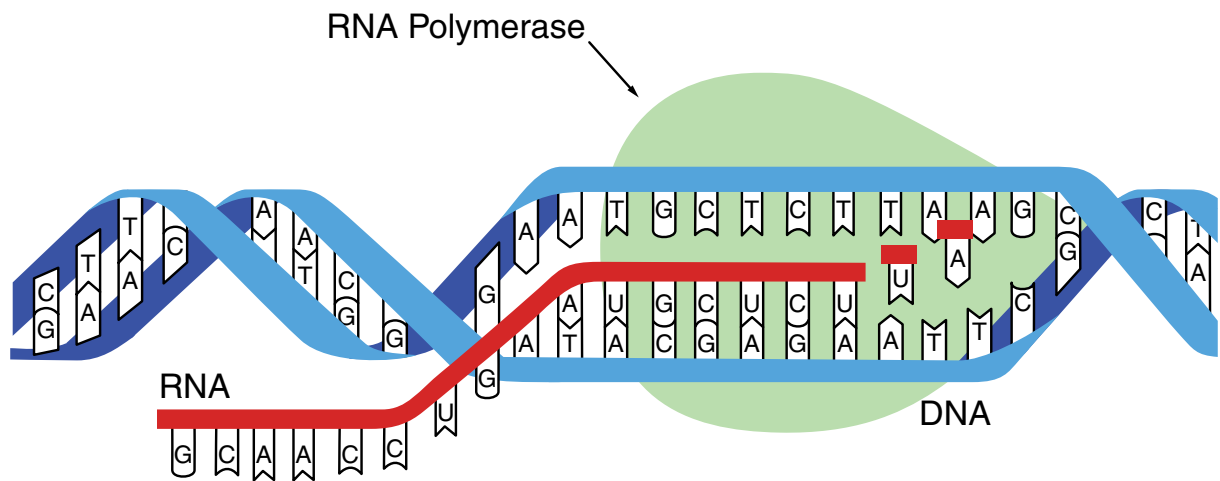

Translation

The components necessary for **translation** are located in the cytoplasm. Translation is the making of proteins by mRNA binding to a ribosome with the start codon that initiates the production of amino acids. A **peptide bond** forms and connects the amino acids together. The sequence of amino acids determines the protein's structure, which determines its function.

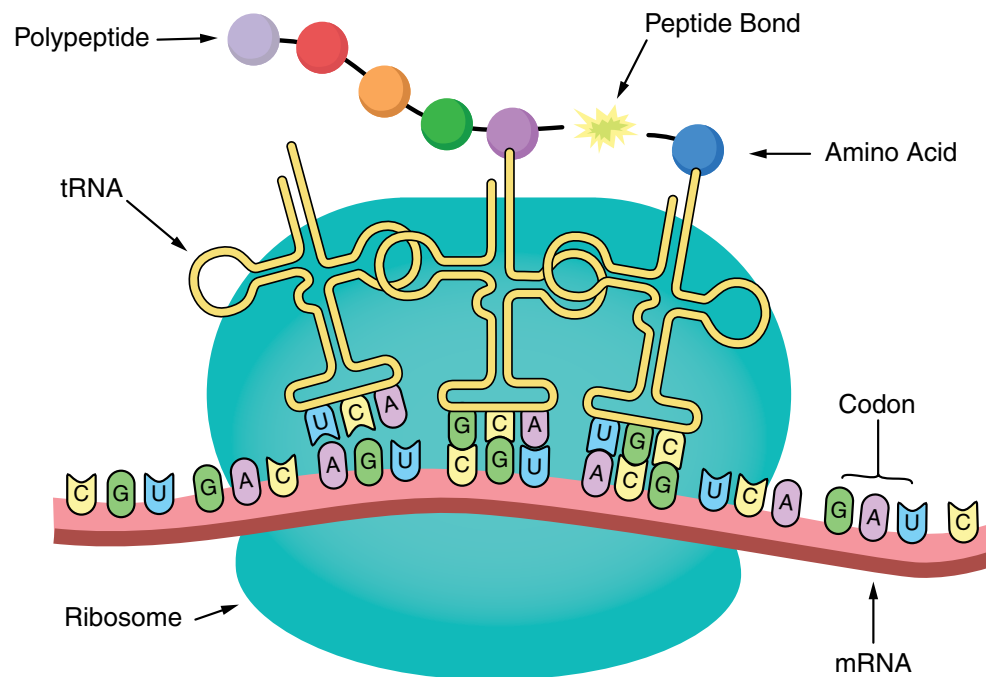

Example

Which type of RNA acts as an interpreter molecule?

- A. mRNA B. pre-mRNA C. rRNA D. tRNA

The correct answer is **D**. Transfer RNA (tRNA) acts as an interpreter molecule, translating mRNA sequences into amino acid sequences.

Let's Review!

- Gregor Mendel developed a simple set of rules that accurately predicts patterns of heredity.
- Mendel proposed a theory that has become the foundation of the science of genetics.
- Biologists can predict the probable outcomes of a cross by using a diagram called a Punnett square.
- A gene is a segment of DNA that transmits information from parent to offspring
- A chromosome is a rod-shaped structure that forms when a single DNA molecule and its associated proteins coil tightly before cell division.
- Deoxyribonucleic acid is a long, thin molecule made of subunits called nucleotides that are linked together in a nucleic acid chain.
- Replication is the process of synthesizing a new strand of DNA.
- Transcription is the first step in using DNA to direct the making of a protein.
- Translation is the process of making proteins.

CHAPTER 14 LIFE AND PHYSICAL SCIENCES

PRACTICE QUIZ

- Which of the following helps differentiate a non-living thing from a living thing?**
 - Energy processing
 - Behavior in nature
 - Occurrence in nature
 - Description of habitat
- What standard is used to make comparisons in experiments?**
 - Sample size
 - Control group
 - Dependent variable
 - Independent variable
- What is the most basic unit of structure in living things?**
 - Cell
 - Organelle
 - Oxygen
 - Pigment
- A researcher discovers a cell that is less than 0.5 millimeters in diameter. This cell has pili surrounding its cell wall. What does the researcher classify this cell as?**
 - Autotroph
 - Eukaryote
 - Heterotroph
 - Prokaryote
- A chemist decides to study reactions occurring in a cell's cytoplasm. Which of the following reactions does she observe?**
 - Mitosis
 - Cell cycle
 - Glycolysis
 - Carbon cycle
- Which process involves crossing over?**
 - Mitosis
 - Meiosis
 - Calvin cycle
 - Cell respiration
- If an organism has a total of 12 chromosomes, 12 is the _____ number of chromosomes.**
 - diploid
 - equivalent
 - haploid
 - neutral
- The sequence of amino acids in a gene determines**
 - the primary structure of a codon.
 - the primary structure of a protein.
 - the primary structure of a nucleotide.
 - the primary structure of a nucleic acid.

CHAPTER 14 LIFE AND PHYSICAL SCIENCES

PRACTICE QUIZ – ANSWER KEY

1. **A.** There are several features that scientists use to identify living things. These features include: how living things process energy, growth and development, reproduction, and homeostasis. **See Lesson: An Introduction to Biology.**
2. **B.** A control group is a factor that does not change during an experiment. Due to this, it is used as a standard for comparison with variables that do change such as a dependent variable. **See Lesson: An Introduction to Biology.**
3. **A.** The most basic unit and building block of all living things is the cell. **See Lesson: Cell Structure, Function, and Type.**
4. **D.** Common characteristics of prokaryotic cells are that they are small and have hair-like structures called pili that surround their cell wall. **See Lesson: Cell Structure, Function, and Type.**
5. **C.** The first step of cellular respiration is glycolysis. This process happens in the cell's cytoplasm, where glucose is broken down to pyruvate, yielding two molecules of ATP. **See Lesson: Cellular Reproduction, Cellular Respiration, and Photosynthesis.**
6. **B.** Meiosis is a form of cell division that occurs when DNA from homologous chromosomes is exchanged. This exchange, or crossing over, increases genetic diversity in a population. **See Lesson: Cellular Reproduction, Cellular Respiration, and Photosynthesis.**
7. **A.** Diploid refers to the full number of chromosomes. **See Lesson: Genetics and DNA.**
8. **B.** The sequence of amino acids in a gene determines the primary structure of a protein. **See Lesson: Genetics and DNA.**