

Model No.: RP-AP088 B/W

RENPHO

True HEPA Air Purifier

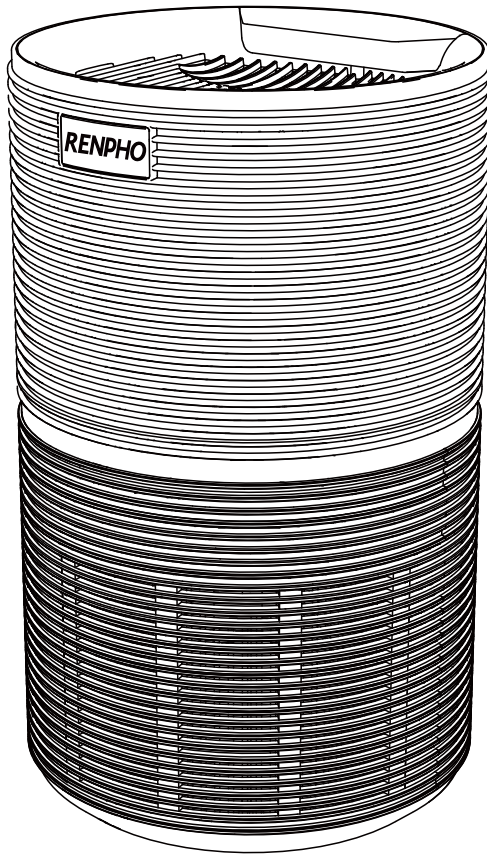

User Manual

Thank you for choosing RENPHO! This air purifier brings fresh air to you whether at home or at work. Choose from low, medium, or high fan speed. The air purifier with 4-stage filtration system(pre-filter,HEPA filter, activated carbon filter and net filter) tackle 99.97% of particles and odors. Plus the soft night light helps lull you to sleep. Enjoy a cleaner breathing space.

Contents

1. Specifications & Package	01
2. Safety Instructions.....	02
3. Product Structure	04
4. Before First Use	05
5. Using The Appliance	07
6. Filter Replacement	09
7. Clean Air Purifier	11
8. Storage	11
9. Environment	11
10. Troubleshooting	12
11. Warranty Information	13
12. Customer Service	13

Specifications

Power Supply	AC 120V 60Hz
Rated Power	32 W
Effective Range	≤ 220 ft ² (≤ 20m ²)
Operating Conditions	Temperature: 23°F~108°F(-5°C~42°C)
Noise Level	≤ 52dB
Clean Air Delivery Rate (CADR)	100CFM (170 m ³ /h)
Standby Power	<0.5W

What's Included

Your RENPHO Air Purifier box includes

- 1 RENPHO Air Purifier
- 1 User Manual
- 1 Warranty Card

Safety Information

IMPORTANT: Please read and comply with all of the instructions and warnings provided in this manual before using the product. Failure to comply with the instructions and warnings provided herein may result in inaccurate results and/or damage to the product itself.

Danger

- **Do not** let water or any other liquid or flammable detergent enter the appliance to avoid electric shock and/or a fire hazard.
- **Do not** clean the appliance with water or any other liquid or a (flammable) detergent to avoid electric shock and/or a fire hazard.

Warning

- Check if the voltage indicated on the bottom of the appliance corresponds to the local mains voltage before you connect the appliance.
- If the mains cord is damaged, you must have it replaced by distributor, or a service center authorized by distributor or similarly qualified persons in order to avoid a hazard.
- **Do not** use the appliance if the plug, the mains cord or the appliance itself is damaged.
- This appliance is not intended for use by persons (including children) with reduced physical, sensory or mental capabilities, or lack of experience and knowledge, unless they have been given supervision or instruction concerning use of the appliance by a person responsible for their safety.
- Children should be supervised to ensure that they do not play with the appliance.
- **Do not** block the air inlet and outlet, e.g. by placing items on the air outlet or in front of the air inlet.

Caution

- This appliance is not a substitute for proper ventilation, regular vacuum cleaning or use of an extractor hood or fan while cooking.
- If the wall socket used to power the appliance has poor connections, the plug of the appliance becomes hot. Make sure you plug the appliance into a properly connected wall socket.
- Always place and use the appliance on a dry, stable, level and horizontal surface.
- Leave at least 40cm free space behind and on both sides of the appliance and leave at least 40cm free space above the appliance.
- **Do not** place anything on top of the appliance and do not sit on the appliance.
- **Do not** place the appliance directly below an air conditioner to prevent condensation from dripping onto the appliance.

- Make sure all filters are properly installed before you switch on the appliance.
- Only use the original filters specially intended for this appliance. Do not use any other filters.
- Avoid knocking against the appliance (the air inlet and outlet in particular) with hard objects.
- Always lift or move the appliance by the handle at the back of the appliance.
- **Do not** insert your fingers or objects into the air outlet.
- **Do not** use this appliance when you have used indoor smoke-type insect repellents or in places with oily residues, burning incense or chemical fumes.
- **Do not** use the appliance near gas appliances, heating devices or fireplaces.
- Always unplug the appliance after use and before you clean it.
- **Do not** use the appliance in a room with major temperature changes, as this may cause condensation inside the appliance.
- The appliance is only intended for household use under normal operating conditions.
- **Do not** use the appliance in wet surroundings or in surroundings with high ambient temperatures, such as the bathroom, toilet or kitchen.
- The appliance does not remove carbon monoxide (CO) or radon (Rn). It cannot be used as a safety device in case of accidents with combustion processes and hazardous chemicals.
- To prevent radio interference, the appliance should be kept at least 2 meters away from any device that uses radio waves.



THIS APPLIANCE HAS A POLARIZED PLUG(one blade is wider than the other).To reduce the risk of electric shock,this plug is intended to fit in a polarized outlet only one way.If the plug does not fit fully in the outlet,reverse the plug.If it still does not fit,contact a qualified electrician to install the proper outlet.

DO NOT ATTEMPT TO MODIFY THIS PLUG OR DEFEAT THIS SAFETY FEATURE IN ANY WAY.

Product Structure

Welcome using our company air purifier, before use please read this manual carefully to operate the product correctly.

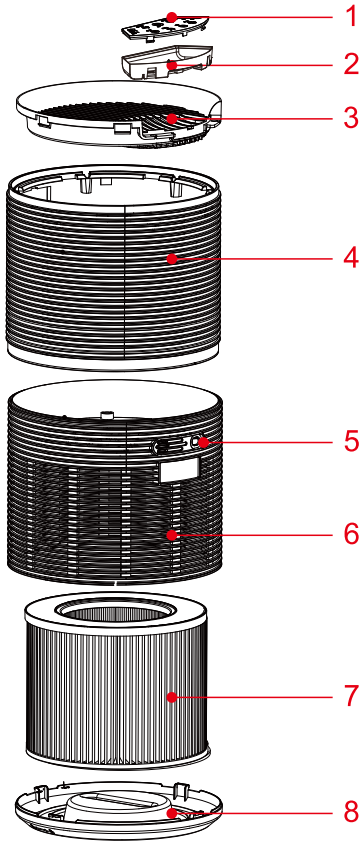

1. Touch-Control Panel
2. Night Light
3. Air Outlet
4. Upper Body
5. Power Cord
6. Air Inlet
7. True HEPA 4-stage Filter
8. Base Cover

Before First Use

Placing the filters

The appliance comes with all filters fitted inside, but you have to remove the packaging of the filters before you can use the appliance. Remove all filters, unpack them and place them back into the appliance as described below.

Note: Make sure you insert the filters in the correct position.

1. Put the appliance upside down on a soft cloth to avoid scratching, to open the base cover, you need to find an arrow point ▲ on the base cover corresponding the **LOCK** position, turn the base cover counterclockwise from **LOCK** to **OPEN** position, then the lock released.

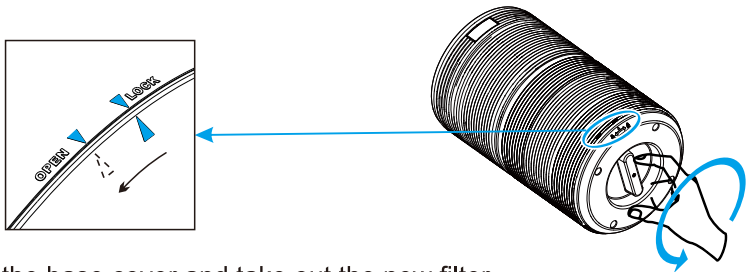

2. Remove the base cover and take out the new filter.

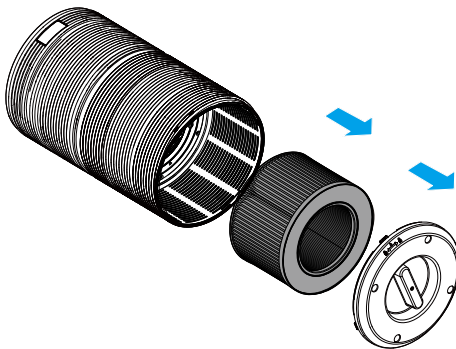

3. Remove the Plastic Packaging from the filter.

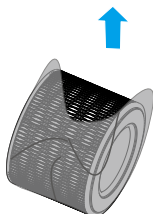

4. Put the filter back into the appliance.

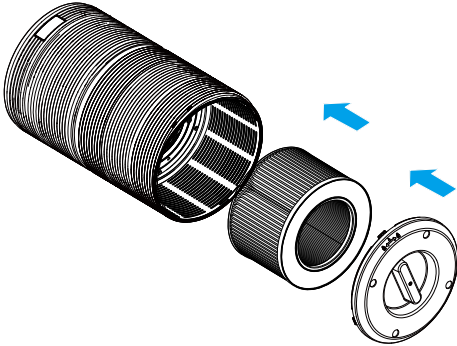

5. Turn the base cover clockwise from **OPEN** position to **LOCK** position, you will hear a "click" sound, the base cover is fastened.

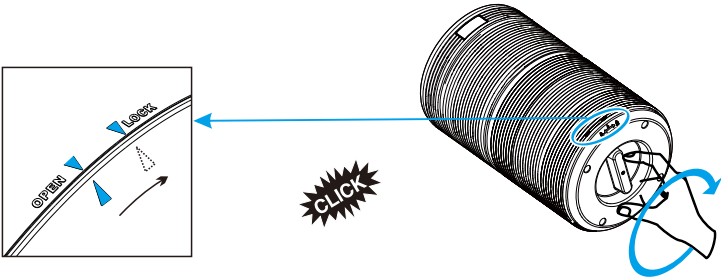

Using The Appliance

About the control panel

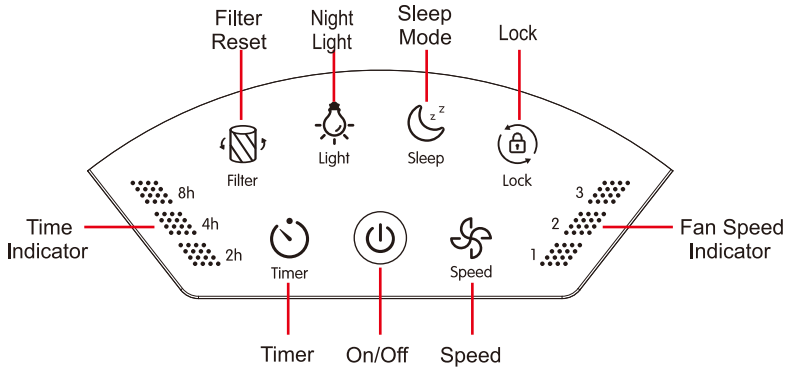

1. Put the plug in the wall socket

All lights will turn on once and you hear a beep.

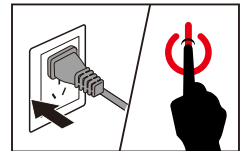

2. Press the power button to switch on the appliance.





Press  button, Night light turns on and Speed at level 2 (Med) .

3. Fan speed adjustment

The fan speed light indicates at which fan speed the appliance is operating. Press Speed button  to adjust fan speed level, there are three levels 1~3 refers to **Low, Medium, High** .

Tips: When the appliance is switched on, the fan speed is at the medium level.





4. Sleep mode

When you use the appliance in Sleep Mode, it works very quietly. Only the  and  buttons (If setting the timer) will be at half brightness, all other buttons light off. Press any other buttons(except  and  buttons) to exist the sleep mode.



5. Light

When the purifier powered on, the light display white.



>> Working status

- 1) Turn on the purifier default open the bright-white light and breathing mode.
- 2) Short press the  button, change to bright-white; then short press once, change to half-bright white; short press once, change to colorful gradient mode; and short press again, turn off the light.
- 3) Long press  button 3 seconds, turn on the breathing mode, and long press 3 seconds, turn off it.
- 4) In colorful gradient status, long press  button 3 seconds, the colors always bright(red, orange, yellow, green, cyan, blue, purple), without breathing mode.
Then long press  3 seconds, turn on color with breathing mode.



>> Standby status

Night color is orange and cold-white. Press  button turn on night light, the light is orange with half-light and you will hear a "beep" sound. Then press  button again, night light is cycle in order by fully bright → cold white, half bright → fully bright → turn off → orange, half bright...

6. Setting timer

1. Press  to turn on or off the timer, and to cycle through timer options (2 hours, 4 hours, or 8 hours).
 2. The air purifier will automatically power off once the timer is finished.
- NOTE: Pressing  or unplugging the air purifier will cancel the timer.

7. Keylock mode

- 1) Press  button to activate Keylock mode , all buttons are locked at this mode; If your house has young child, we suggest use this mode.
- 2) To cancel the keylock mode, just press and hold  button for 3 seconds.

8. Filter replacement light

When indicator  lights, it means that you should check the filter if it need to be cleaned or replaced.

Note: The filter's lifetime is based to your house air quality and using time. Using the appliance in a humid environment will reduce the lifetime of the filter.

9. Memory Function

When the air purifier is plugged in, it will remember its previous fan speed setting.

Filter Replacement

>> When Should I Replace the Air Filter?

It is recommended to change the air filter every 6–8 months. However, you may need to change your filter sooner or later depending on how often you use your air purifier and your house air quality. It is important to watch out for the following signs of expired filter:

- Increased operating noise
- Decreased airflow
- Clogged filter
- Increased presence of odors

NOTE:

- The environment in which the air purifier being used may also extend or shorten the lifetime of the the air filter. Using your air purifier in an environment of relatively high pollution may mean you will need to change the air filter more often.
- If the air pollution in your environment is very high, there is a possibility that the filters may not be completely effective and may need to be replaced before the  lights up.
- Remember to reset the air purifier after changing the air filter.
- Using the appliance in a humid environment will reduce the lifetime of activated carbon filter and HEPA filter.

Tip: Only use Official RENPHO replacement parts to maintain product performance. (Search for: RP-AP088-F1/F2)

>> How to replace the Air Filter?

1. Switch off the appliance and unplug it. (a)
2. Put the appliance upside down on a soft cloth to avoid scratching, to open the base cover, you need to find an arrow point ▲ on the base cover corresponding the **LOCK** position, turn the base cover counterclockwise from **LOCK** to **OPEN** position, then the base cover released. (b)

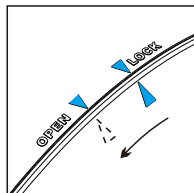
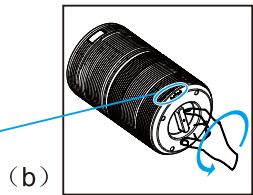
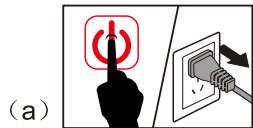

3. Remove the old filter. (c)

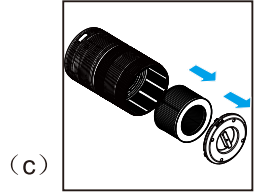

4. Remove the packaging material of the new filter. (d)

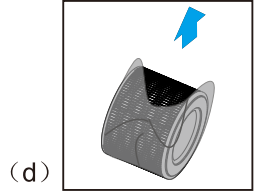

5. Put the new filter back into the appliance. (e)

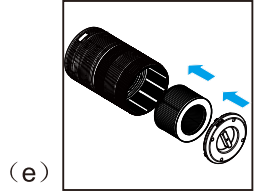

6. Turn the base cover clockwise from **OPEN** position to **LOCK** position, you will hear a "click" sound, the base cover is fastened. (f)

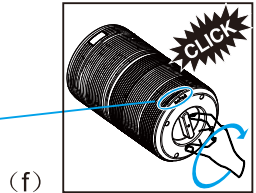
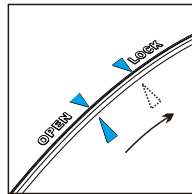

7. Put the plug in the wall socket and switch on the appliance again. (g)

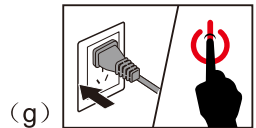

8. Reset Filter's lifetime.

After replacing the filters, when you switch on the appliance, '⏸' the replace filter light still lights up. You need to reset the filter 's lifetime sensor, so that the appliance can calculate the filters' lifetime.

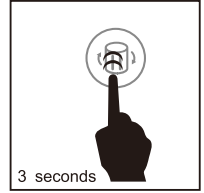

- 1). Plug in the air purifier and turn it on.
- 2). Press and hold '⏸' for 3 seconds.
- 3). Release '⏸' and the light will turn off, indicating that the reset is complete.

>> Filter Replacement Force Mode

When using the air purifier in an environment of heavy pollution, the lifespan of the air filter may be significantly reduced. You can change the filters even if '⏸' does not light up. Follow the steps below to perform a hard reset.

- 1). Replace the air filters as mentioned in the Filter Replacement section.
- 2). Plug in the air purifier and keep in standby mode.
- 3). Press and hold '⏸' for 3 seconds, and it will light up.
- 4). Press and hold '⏸' again for 3 seconds, and it will turn off. The reset is now complete.

Clean Air Purifier

In order to keep your purifier working with more efficiency and life-time, clean the filter (pre-filter side only) every 2 weeks with the Instruction Below:

- 1). Clean out any dust, hair, or furs remain on the pre-filter by using the vacuum hose.
- 2). Clean out any dust, hair, or furs remain on the bottom cover by using the vacuum hose.
- 3). DO NOT wash the filter with any water or liquid.

Storage

Unplug the power cord, then wipe the machine clean, put the appliance in the packing bag, then put it in a dry place away.

Environment

Do not throw away the appliance with the normal household waste at the end of its life, but hand it in at an official collection point for recycling. By doing this, you help to preserve the environment.

Troubleshooting

This chapter summarizes the most common problems you could encounter with the appliance. If you are unable to solve the problem with the information below, contact us directly via e-mail at: support@renpho.com or phone: 1-844-417-0149.

Problem	Cause	Solution
Air purifier does not power on.	Unit is not plugged into an electrical outlet.	Connect the plug to a powered electrical outlet.
	Outlet is not working properly.	Try plugging the air purifier into a different outlet.
	Power button has not been pressed after plugging in the air purifier.	Press '⏻' once to turn on the air purifier.
	Power cord is damaged.	Immediately discontinue use and contact Customer Support .
	Air purifier is defective or malfunctioning.	
Air purifier does not respond to button controls.	Air purifier is not plugged into an outlet.	Connect the plug to a powered electrical outlet.
	Air purifier is defective or malfunctioning.	Immediately discontinue use and contact Customer Support.
Air purifier makes an unusual noise while operating.	Filter is dirty.	Replace the air filter as instructed in the Filter RePlacemEnt section.
	Filter does not fit properly.	Properly place filter as noted in the Before first use and Filter RePlacemEnt sections.
	Foreign object inside the unit.	Immediately discontinue use and contact Customer Support . DO NOT attempt to open the air purifier.
	Filter packaging has not been removed.	Remove filter from packaging before use.
Significantly reduced airflow.	Filter packaging has not been removed.	Remove filter from packaging before use.
	Fan speed is low.	Press '🌀' to adjust fan speed.
	Filter needs to be replaced.	Replace the air filters as instructed in the Filter RePlacemEnt section.
	Not enough clearance on all sides of the purifier.	Ensure there is at least 38 cm (15 inches) of clearance on all sides of the purifier.
Poor air purification quality.	Filter needs to be replaced.	Replace the air filters as instructed in the Filter RePlacemEnt section.
	Room is too large for the air purifier's	Ensure the room is smaller than applicable area.
	Air inlet or outlet is blocked.	Remove objects blocking air inlet or outlet.
	Filter not properly placed in housing.	Properly place filters as noted in the Before first use and Filter RePlacemEnt sections.
Filter reset button is still illuminated after replacing the air filter.	The air purifier has been reset incorrectly.	See the Filter RePlacemEnt section on how to properly reset the unit.
Air purifier turns on, then suddenly turns off.	Air purifier is defective or malfunctioning.	Immediately discontinue use and contact Customer Support . DO NOT attempt to open the air purifier for self-servicing.
Air purifier beeps repeatedly after being powered on or plugged in.		

Warranty Information

RENPHO provides 2-Year warranty for all products to be of the highest quality in material, craftsmanship, and service, effective starting from the date of purchase.

>> Terms & Policy

RENPHO will replace any product found to be defective due to manufacturer flaws based on eligibility. Refunds are available within the first 30 days of purchase. Refunds are only available to the original purchaser of the product.

This warranty only to personal use and does not extend to any product that has been used for commercial, rental, or any other use in which the product is not intended for. There are no warranties other than the warranties expressly set forth with each product. This warranty is non-transferable. RENPHO is not responsible in any way for any damages, losses or inconveniences caused by equipment failure or by user negligence, abuse, or use noncompliant with the user manual or any additional safety, use, or warnings included in the product packaging and manual.

This warranty does not apply to the following:

- Damage due to abuse, accident, alteration, misuse, tampering or vandalism.
- Improper or inadequate maintenance.
- Damage in return transit.

RENPHO assumes no liability for damage caused by the use of the product other than for its intended use or as instructed in the user manual.

>> Defective Products & Returns

Should your product prove defective within the specified warranty period, please contact Customer Support via support@renpho.com with your **ORDER NUMBER**.

Customer Service

We have an award-winning warranty, exchange, and customer service team that guarantees hassle-free solutions to any issue you might have within 24 hours.

Email: support@renpho.com

Tel: 1-844-417-0149

Support Hours: 9:00 am - 4:30 pm

Web: <https://www.renpho.com>

JOICOM CORPORATION

165 E. Freedom Ave., Anaheim, California, 92801, United States