



Audiopipe®

Hwy 836, U.S.A.



User's Manual

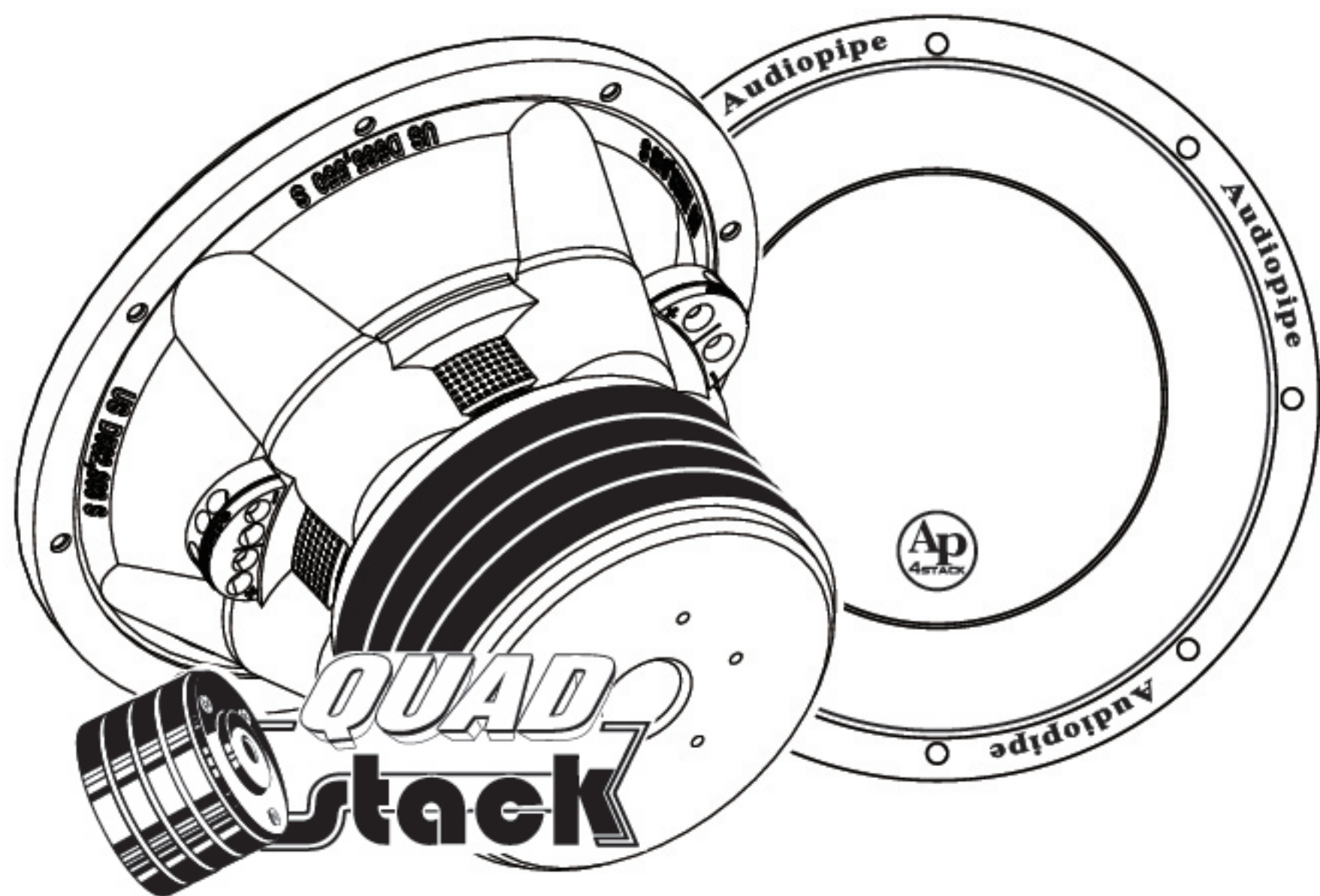

Patent No.: US D523,848 S US D565,550 S US D582,893 S

TXX-BDC4-6

TXX-BDC4-8

TXX-BDC4-10

TXX-BDC4-12

TXX-BDC4-15



MEMBER

All Audiopipe products are designed, manufactured and tested to perform in harsh environments. From our entry level products to our high end series, Audiopipe is your best choice for competition level performance. We welcome you to Team Audiopipe.

For more information, please visit your authorized Audiopipe dealer or:

WWW.AUDIOPIPE.COM

Introduction:

Congratulations on your purchase of an Audiopipe subwoofer. Your Audiopipe subwoofer has been engineered to produce the highest quality sub-bass performance in your vehicle. Audiopipe dealers have the knowledge, skills to build high-quality enclosure that will maximize the performance of your subwoofer. We highly recommend that you have your enclosure built by an Audiopipe authorized dealer. For more dealer information in your area do visit .

All Audiopipe products are designed, manufactured and tested to perform in the harsh environments. From our entry level products to our high end series, Audiopipe is your best choice for competition level performance.

We welcome you to team Audiopipe.....

Table of Contents:

Warranty _____	1
Dimensions _____	2
Specifications _____	3
Building an Enclosure _____	4
Wiring Diagrams _____	5
Sealed Applications _____	6-7
Vented Applications _____	8-9

Audiopipe Limited warranty

Audiopipe warrants this Subwoofer to be free of defects in material and workmanship for period of 1 year from the original purchase date with original receipt. Products found to be defective during the warranty period will be repaired or replaced (with a product deemed to be equivalent) at Audiopipe's discretion. Warranty replacements may have some cosmetic scratches and blemishes. This warranty only applies to the original purchaser of the product purchased from an Audiopipe authorized dealer.

Limit on Implied warranties

Any applicable implied warranties are limited in duration to the period of the express warranty as provided herein beginning with the date of the original purchase at the retail, and no warranties, whether express or implied, shall apply to this product thereafter. Some states do not allow limitations on implied warranties, therefore these exclusions may not apply to you. This warranty gives you specific legal rights and you may also have other rights which vary from state to state.

What is not covered

- The cost of shipping
- Damage due to improper installation
- Any cost or expense related to the removal or reinstallation of product
- Product which has the serial number defaced, altered or removed
- Freight damage
- Product not purchased from an unauthorized dealer
- Damage through negligence, misuse, accident or abuse, repeated returns maybe considered abuse

How to obtain service

All warranty returns should be sent to Audiopipe freight prepaid and must be accompanied by proof of purchase (a copy of the original receipt) listing the customer name, dealers name, invoice number and product purchased. Items sent freight collect or COD will be refused. Call the Audiopipe customer service number 9 am to 5pm eastern standard time at 1-877-AUDIOPIPE (1-877-283-4674) for a return authorization number (RMA). Package all defectives items in the original package or in a package that will prevent shipping damages and return to **Audiopipe 1195 NW 97th Ave Miami, Florida 33172**. Audiopipe strives to maintain a goal of 24hrs return following receipt of the goods. Delays may be incurred if lack of replacement inventory or parts is encountered.

Dimensions:

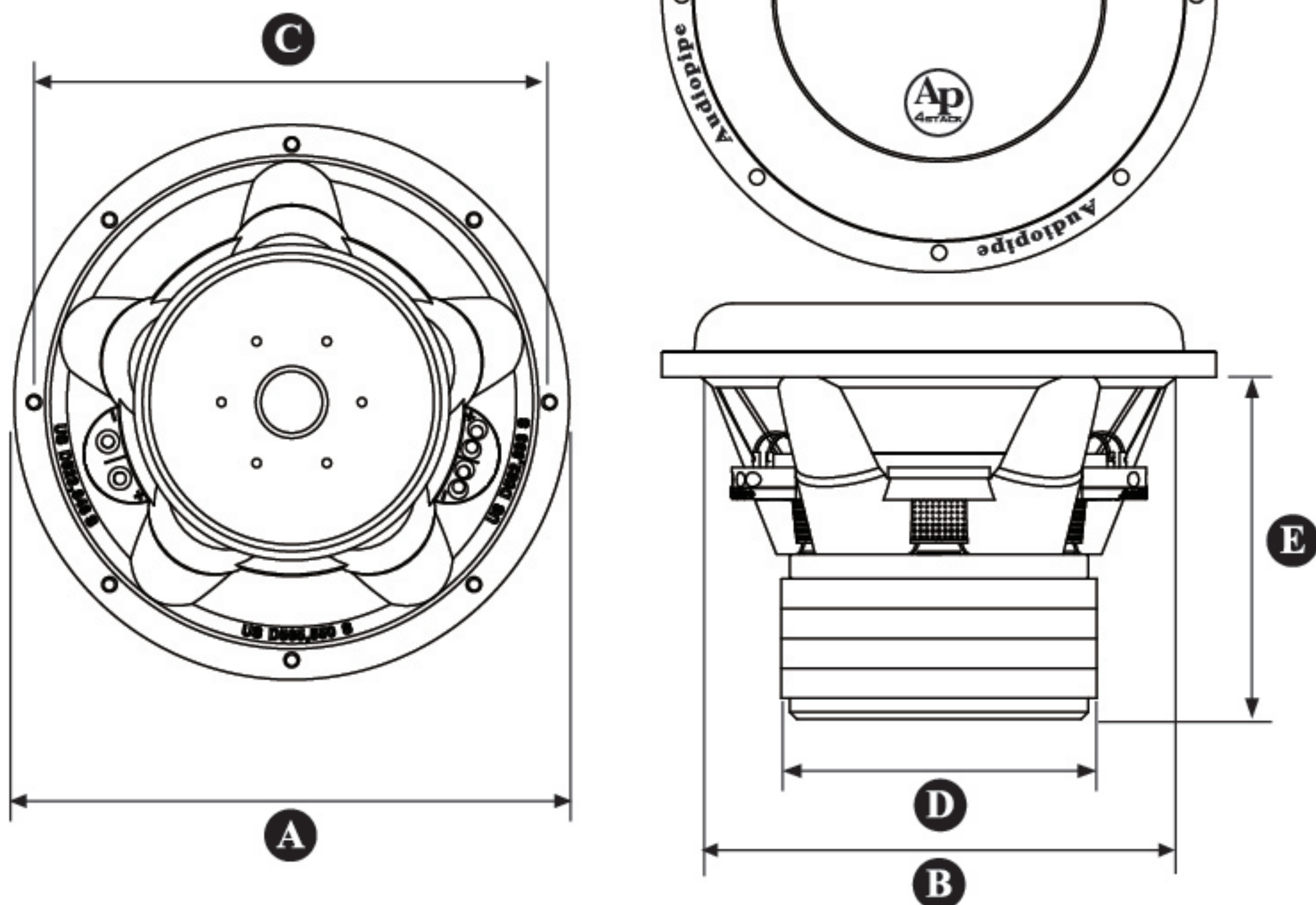

	TXX-BDC4-6	TXX-BDC4-8	TXX-BDC4-10	TXX-BDC4-12	TXX-BDC4-15
Nominal Diameter	Ø165mm 6.5"	Ø203mm 8"	Ø254mm 10"	Ø300mm 12"	Ø381mm 15"
Overall Diameter(A)	Ø180mm 7"	Ø222mm 8 3/4"	Ø266mm 10 1/2"	Ø316mm 12 7/16"	Ø393mm 15 1/2"
Mounting Hole Diameter(B)	Ø152mm 6"	Ø188mm 7 13/16"	Ø225mm 8 7/8"	Ø275mm 10 7/8"	Ø351mm 13 7/8"
Bolt Hole Circle(C)	Ø162mm 6 3/8"	Ø200mm 7 7/8"	Ø242mm 9 1/2"	Ø294mm 11 9/16"	Ø370mm 14 9/16"
Magnet Diameter(D)	Ø126mm 5"	Ø156mm 6 1/8"	Ø156mm 6 1/8"	Ø180mm 7 1/16"	Ø190mm 7 1/2"
Mounting Depth(E)	120mm 4 3/4"	148mm 5 13/16"	173mm 6 13/16"	200mm 7 7/8"	225mm 8 7/8"
Driver Displacement	2.83 L 0.1 cu ft	3.11 L 0.11 cu ft	3.40 L 0.12 cu ft	4.25 L 0.15 cu ft	4.53 L 0.16 cu ft
Net Weight	4.3kg 9.5 lb	8.1kg 17.9 lb	9kg 19.82 lb	14kg 30.9 lb	18kg 39.7 lb

Features

- Dual Voice Coil BASV
- Powdered Black Paint Aluminum Basket
- Audiopipe “EASY CONNECT” terminal allows for convenient parallel or series wiring
- Quad-stacked Magnet

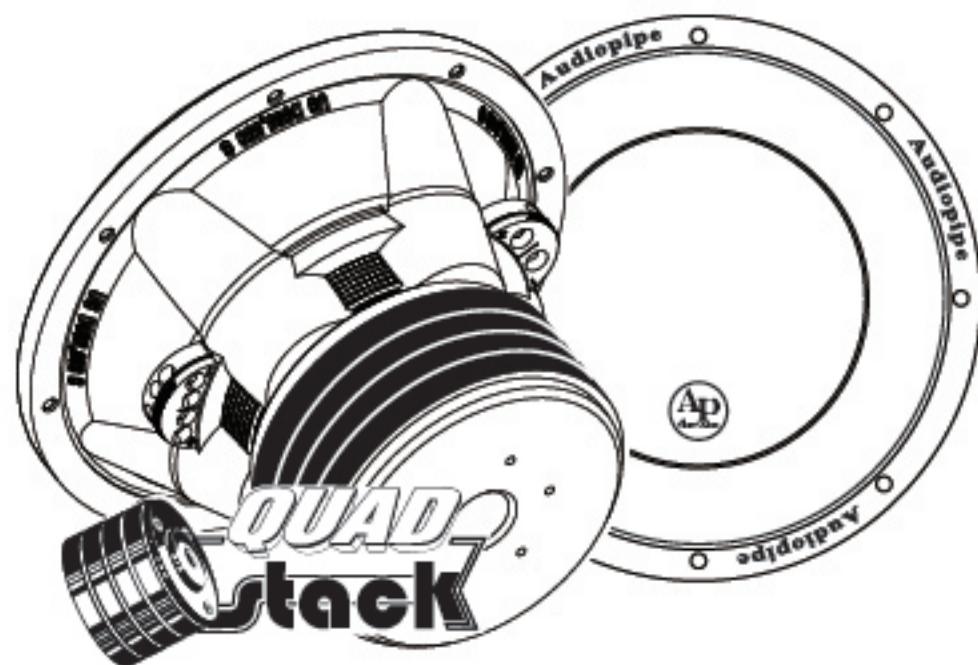

Specifications:

	TXX-BDC4-6	TXX-BDC4-8	TXX-BDC4-10	TXX-BDC4-12	TXX-BDC4-15
Fs (Hz)	60	45	38	33	30
Re (Ohms)	2x3.6	2x3.6	2x3.6	2x3.6	2x3.6
Le (mH)	2.7	2.4	5.1	5.6	5.6
Qts	0.48	0.44	0.39	0.35	0.37
Qes	0.63	0.53	0.49	0.42	0.44
Qms	2.2	2.5	2.0	2.2	2.3
Cms (m/N)	0.1	0.12	0.8	0.95	0.67
Vas (L)	3	7	14	38	69
Mms (g)	63	103	216	346	500
Mmd (g)	62	101	213	340	486
No (%)	0.12	0.1	0.15	0.21	0.31
SPL (dB-1W/1M)	84	85	85	88	90
BL (T*M)	17	20	28	34	37.5
Sd (cm ²)	137	204	346	530	850
Krm (mOhms)	18	33	40.7	64	45
Erm	0.78	0.74	0.76	0.72	0.77
Kxm (mH)	62	132	134	146	175
Exm	0.7	0.63	0.68	0.68	0.67
Frequency Response (Hz)	50-1,500Hz	35-1,200Hz	30-1,200Hz	20-900Hz	18-800Hz
Voice Coil Diameter	2"/50mm	2.5"/60mm	2.5"/65mm	3"/75.5mm	3.3"/84mm
Voice Coil Height	1"/25mm	1.18"/30mm	1.77"/45mm	1.9"/48mm	1.9"/48mm
Voice Coil Layers	4	4	4	4	4
Magnetic Gap Height	0.31"/8mm	0.39"/10mm	0.47"/12mm	0.55"/14mm	0.55"/14mm
Linear Excursion, pk-pk(X _{max})	0.33"/8.5mm	0.39"/10mm	0.65"/16.5mm	0.65"/17mm	0.65"/17mm
Maximum Excursion, pk-pk	1.5"/38mm	1.5"/38mm	2"/50mm	2"/50mm	2"/50mm
Magnet Weight	80 oz./2.3 kg	150 oz./4.3 kg	170 oz./4.8 kg	220 oz./6.4 kg	250 oz./7.1 kg
Woofer Displacement	2.83L/0.1 cubic ft.	3.11L/0.11 cubic ft.	3.39L/0.12 cubic ft.	4.25L/0.15 cubic ft.	4.53L/0.16 cubic ft.
Net Weight	9.5 lbs./4.3 kg	17.9 lbs./8.1 kg	26.5 lbs./12 kg	30.9 lbs./14 kg	39.7 lbs./18 kg
Power Rating	250/500W	500/1000W	900/1800W	1100/2200W	1400/2800W

Building an enclosure

When building an enclosure, the walls should be as rigid as possible and not flex. Flexing of the enclosure can drastically decrease your subwoofers performance. It is recommended that Enclosures be built using 3/4" MDF, be glued and secured with nails or screws. Add bracing to each of the larger unsupported panels. Your enclosures construction has a significant bearing on how well your subwoofers perform. When designing your enclosure keep in mind and account for wood thickness, port and woofer displacement.

Calculating volume

Measure the available space for the enclosure and using the formula (H X W X L divided by 1728) determine the appropriate measurements needed in order to achieve the desired cubic enclosure. If two facing sides are of uneven lengths add them together and divide by two.

Wiring subwoofers

When designing your system it is important to achieve a good power match between your subwoofer amplifier and the subwoofers capability. RMS power should be considered as a regular method of driving the subwoofer, make use of the power without drastically overdriving the amplifier. Amplifiers cannot read how many subwoofers are in the connection, they normally read the final impedance or otherwise known as ohms. It is important to properly match your amplifiers normal operating impedance with right subwoofer configuration.

Wiring options

The TXX-BDC4 series of subwoofers are available with dual 4 Ohms voice coils. Both coils must be connected to a source of amplification. A dual 4 Ohms woofer can be configured in parallel to provide a 2 Ohm load. A dual 4 Ohms woofer can be also configured in series to provide a 8 Ohms load. The terminal with the red markings is the positive while the black terminals represent the negative.

4 ohm DVC Speaker = 2 ohm Load

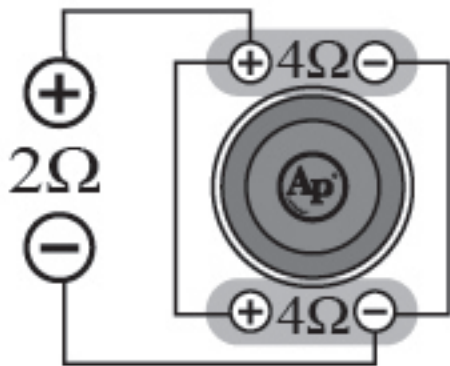

2 ohm DVC Speaker = 4 ohm Load

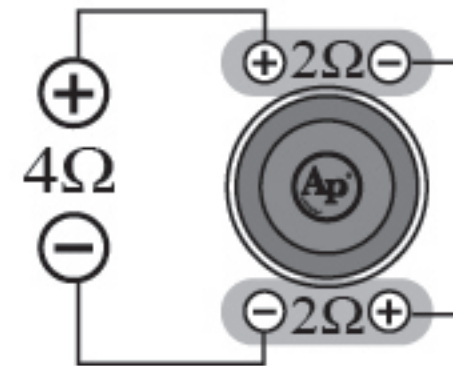

4 ohm DVC Speaker = 1 ohm Load

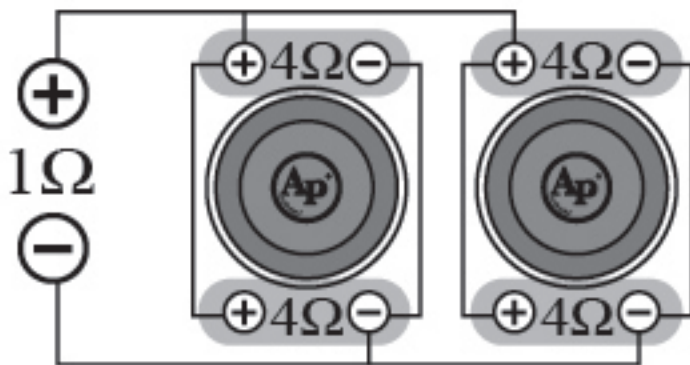

2 ohm DVC Speaker = 2 ohm Load

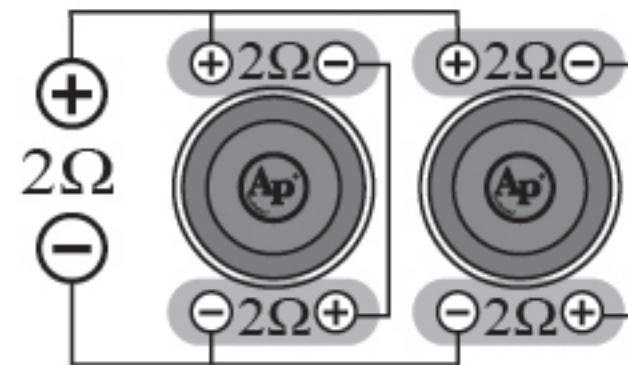

4 ohm DVC Speaker = 4 ohm Load

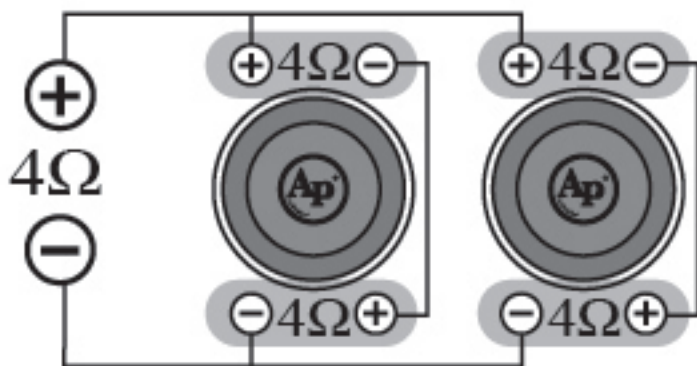

4 ohm DVC Speaker = 2.67 ohm Load

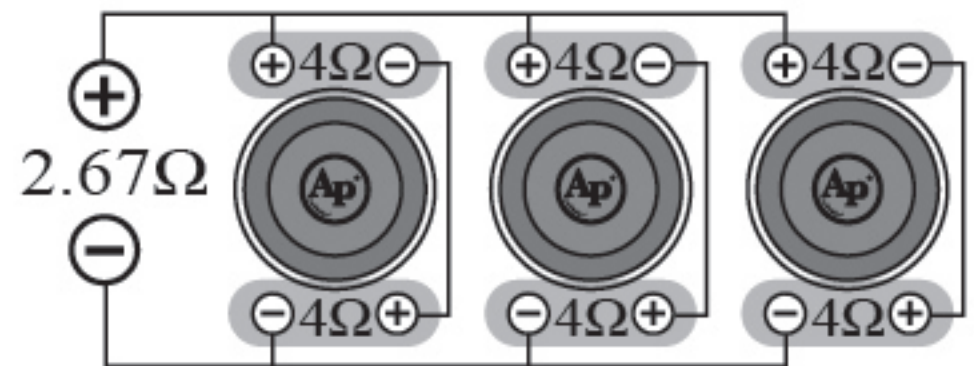

4 ohm DVC Speaker = 2 ohm Load

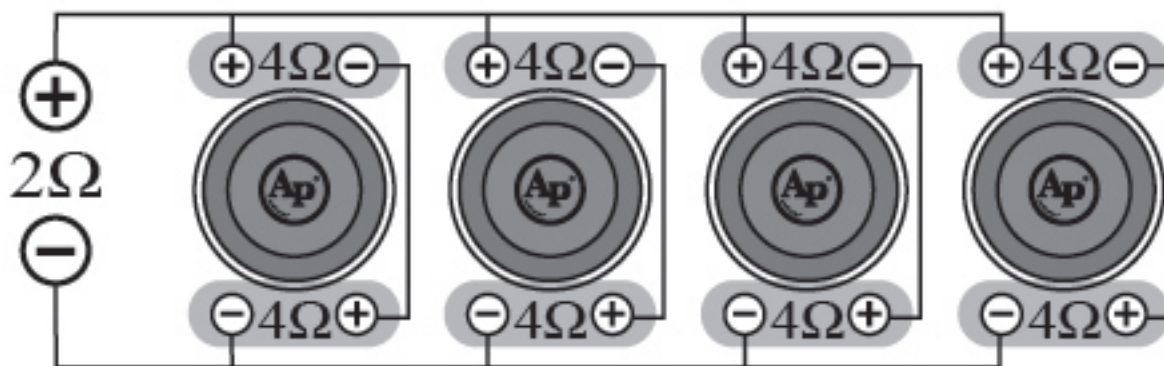

2 ohm DVC Speaker = 4 ohm Load

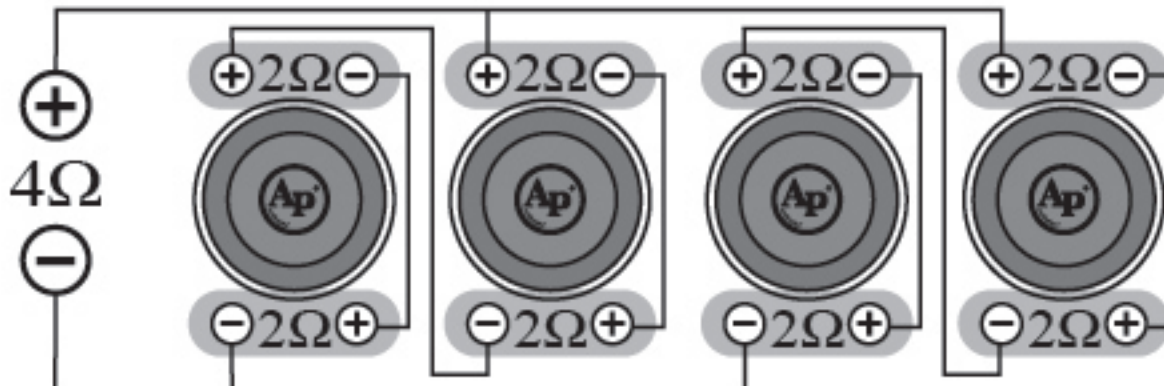

Sealed enclosure

This type of enclosure is classic and the simplest to build among most installers. The box volume will directly impact the performance of the subwoofer, it is important to make sure the enclosure is properly sealed. Use some type of sealant on the seams as this will ensure a solid construction and prevent air leaks. Larger enclosures will provide a flatter response and deeper bass where as a smaller box will provide a generally higher output for greater SPL. All sealed enclosure designs should be filled to 50% with loose ply-fill. The use of poly-fill will slightly decrease efficiency but will deepen and extend the low frequency.

Primary advantages

- Small enclosure
- Good low frequency extension and control
- Simple to build
- Excellent for sound quality

Calculating volume

Measure the available space for the enclosure and using the formula (H X W X L divided by 1728) determine the appropriate measurements needed in order to achieve the desired cubic enclosure. If two facing sides are of uneven lengths add them together and divide by two.

The enclosure recommendations listed are external dimensions using 3/4" thick wood. If you use 5/8" material subtract 1/4" from each dimension, we strongly recommend not use material less than 5/8".

****Note the enclosures listed in the manual account for the driver displacements.***

Recommended Sealed Enclosure

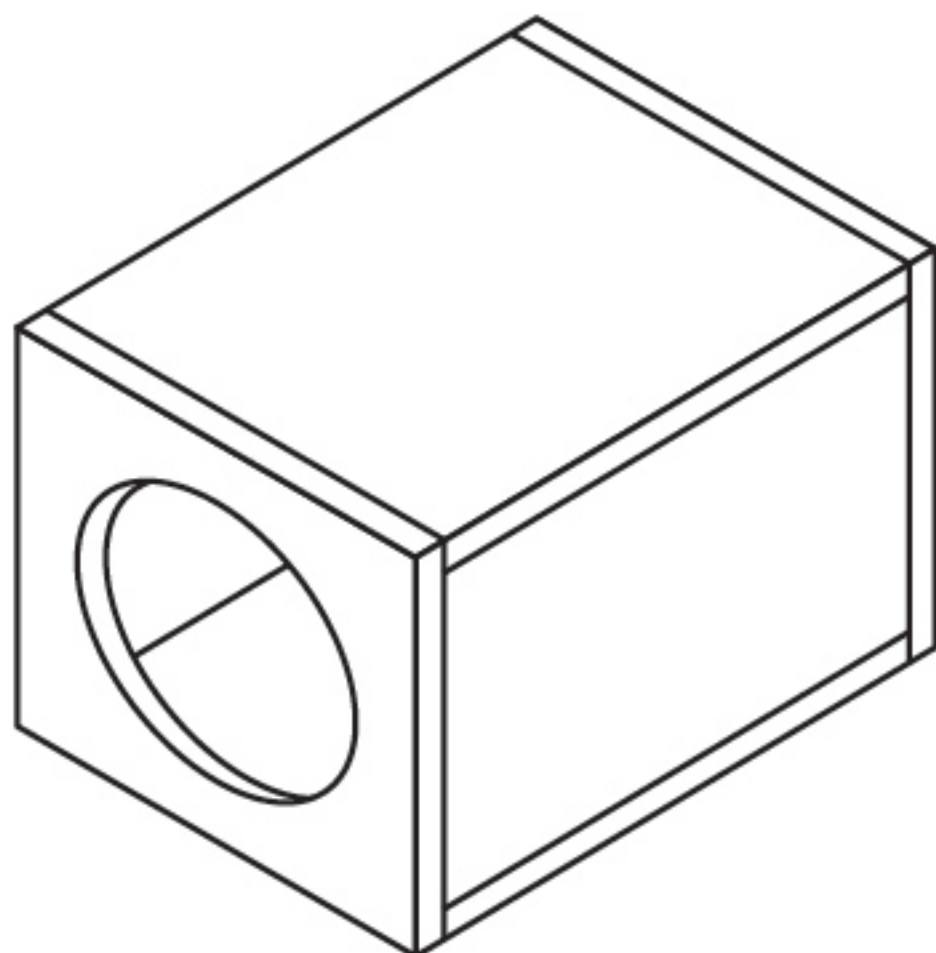

Subwoofer	Recommended Sealed Enclosure	
	Everyday Bass Performer	Competition Bass Performer
TXX-BDC4-6	0.25 cu ft.	0.35 cu ft.
TXX-BDC4-8	0.5 cu ft.	0.6 cu ft.
TXX-BDC4-10	1.0 cu ft.	1.5 cu ft.
TXX-BDC4-12	1.75 cu ft.	2.0 cu ft.
TXX-BDC4-15	3.25 cu ft.	3.93 cu ft.

Vented enclosure

This type of enclosure is the installer's top choice for high performance SPL levels and requires a deeper understanding in order to achieve maximum efficiency. The most notable difference between the sealed and vented enclosure is the port, this port is used to tune the enclosure. Larger boxes tend to be easy to tune to lower frequencies while medium and small boxes are easier to tune to higher frequencies. The vented design is less linear in response than the sealed but with noticeably more output at the tuning frequency.

Primary advantages

- Low distortion around port
- High output for SPL
- Tuning frequency can easily adjust depending on length of port

Port displacement

All of the cubic ft. provided in this manual includes the speaker displacement. For vented enclosures the port displacement must be calculated and added to your internal volume. If using 3/4" MDF wood add the thickness of the wood 1.5" to the H and the W, next use the outer dimension of the port so $(H+1.5) \times (W+1.5) \times L = (\text{result})$. Use the (result) and divide it by 1728, this new result is then added to your internal cubic enclosure.

Recommended Ported Enclosure

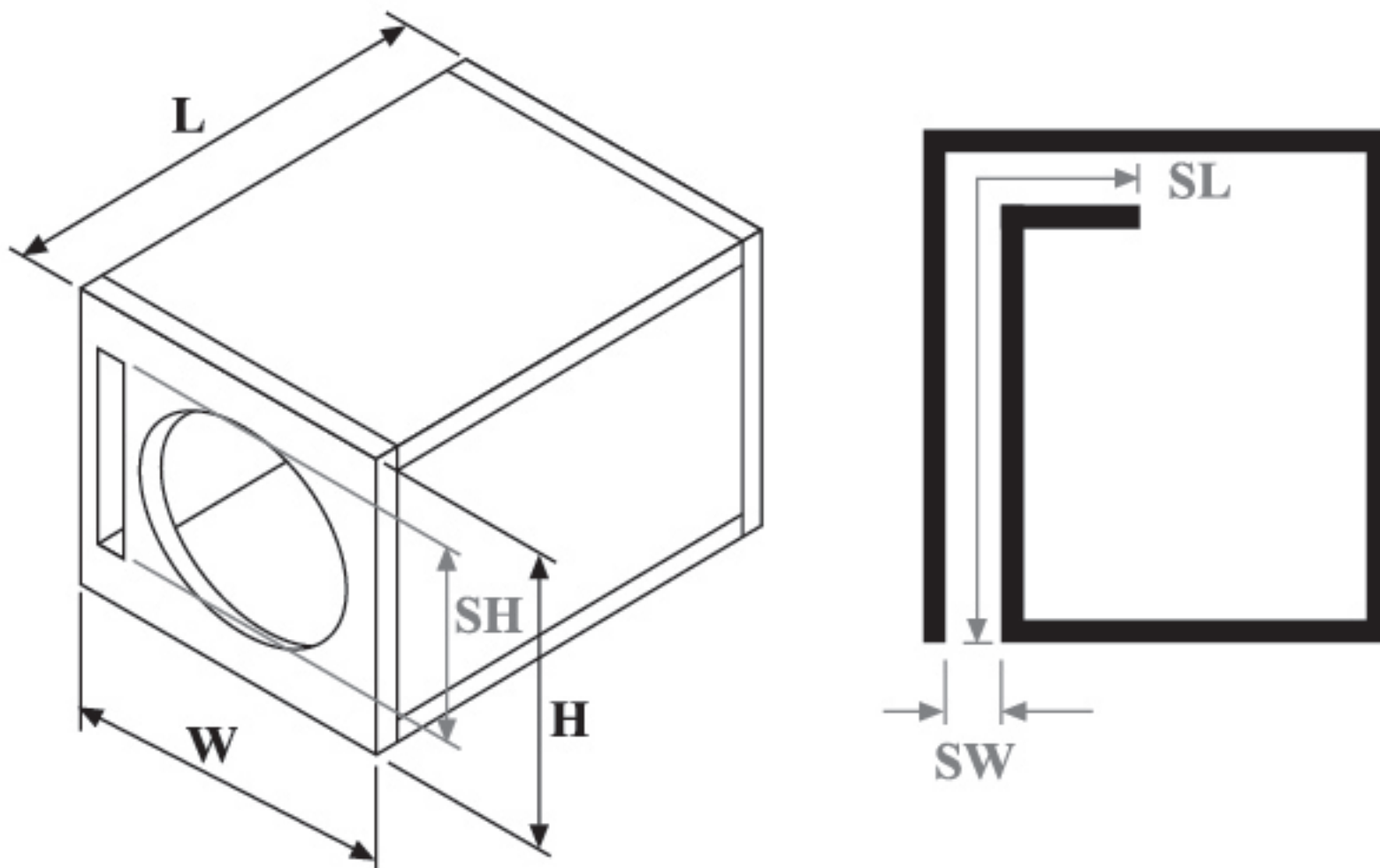

Subwoofer	Recommended Ported Enclosure				
	Vented Enclosure	Everyday Bass Performer		Competition Bass Performer	
	Dimensions Width x Height x Length	Volume	Slot Port Internal Dimensions (Slot Width x Slot Height x Slot Length)	Volume	Slot Port Internal Dimensions (Slot Width x Slot Height x Slot Length)
TXX-BDC4-8	9" x 9" x 10"	0.42 cu ft.	1.2" x 4.5" x 23"	0.53 cu ft.	1.2" x 5" x 23"
TXX-BDC4-10	13" x 13" x 15"	1.5 cu ft.	2" x 10" x 20"	2.0 cu ft.	2.5" x 11" x 20"
TXX-BDC4-12	20" x 14" x 21"	2.15 cu ft.	1.87" x 12" x 21.6"	3.25 cu ft.	1.87" x 12" x 31.6"
TXX-BDC4-15	25" x 17" x 25"	3.5 cu ft.	3" x 15" x 20"	4.6 cu ft.	3" x 15" x 20"

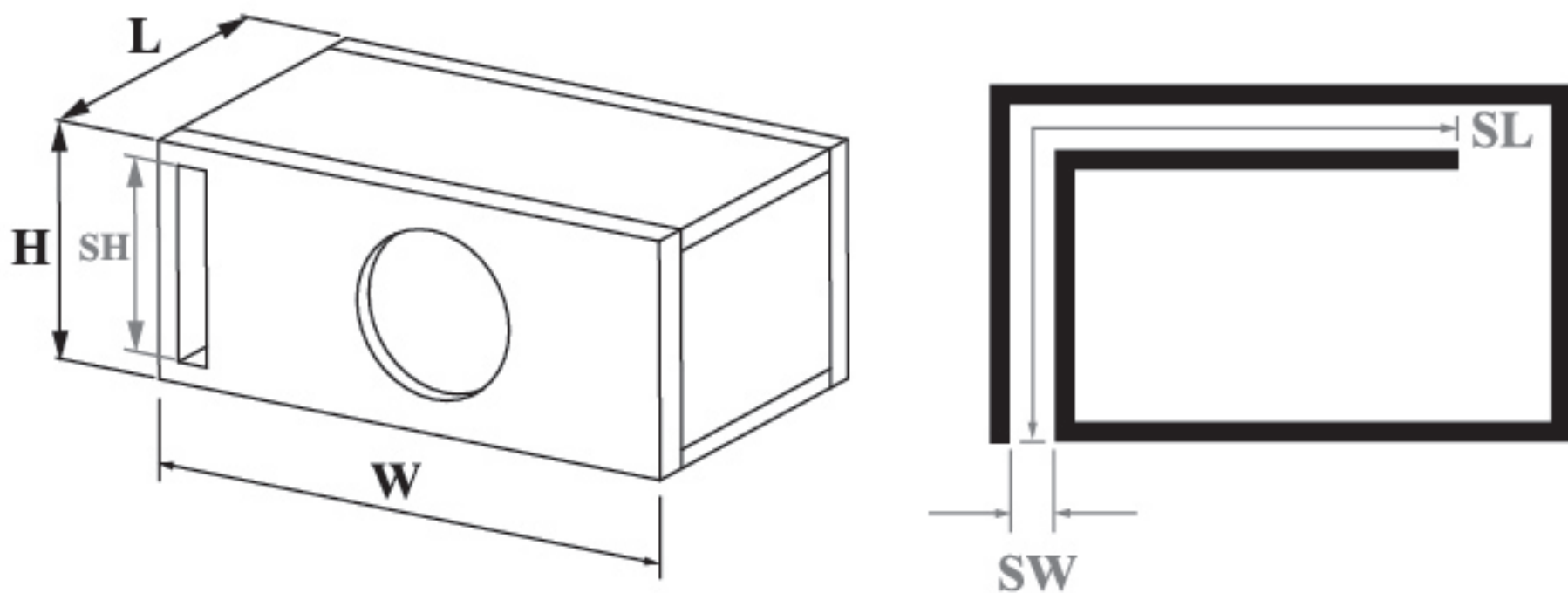

Subwoofer	Recommended Ported Enclosure	
	Vented Enclosure	Slot Port Internal Dimensions
	Dimensions Width x Height x Length	Slot Width x Slot Height x Slot Length
TXX-BDC4-6	16.4"x8.5"x19.8"	1.1"x7"x26.1"

Note:

If you're going to bend the port at 90°, you will need to add 1/2 of the port width to the length!

***** See the example we have provided for you below:

Fig. 1

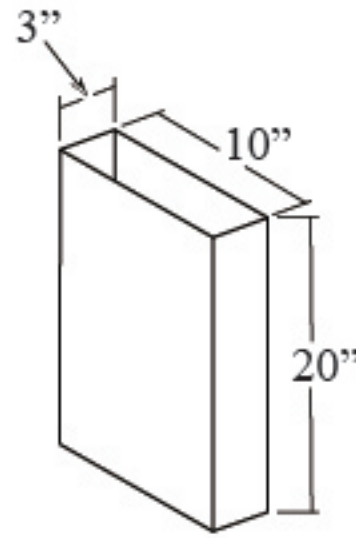
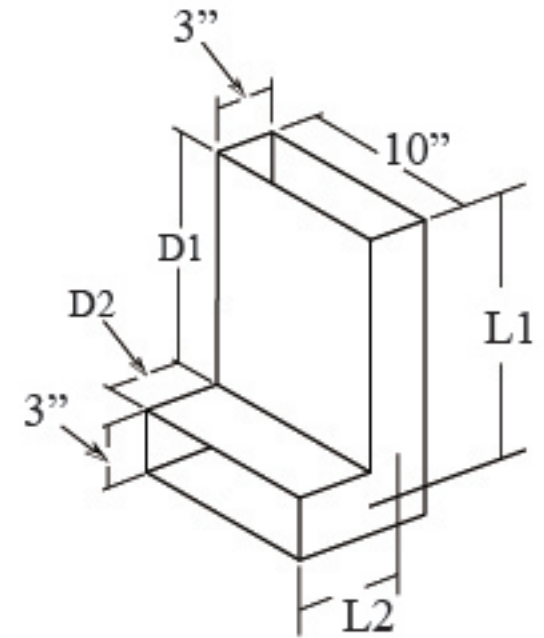

Fig. 2



Example:

(Fig. 1)

$W_{port}=3''$

$H_{port}=10''$

$L_{port}=20''$

(Fig. 2)

Since W_{port} is 3" you need to add 1.5" (1/2 of W_{port}) to L_{port} .

This means that $L1=D1+1.5''$, $L2=D2+1.5''$.

$L_{port}=L1+L2$

Always measure L1 and L2 down the center to get an accurate measurement!