



PROGRESSIVE THINKING IN DESIGN

SILVERBACK BIKES



#BORNTOBEEFAST

AN ENGINEERING MASTERCLASS.



#BORNTOBEBFAST

SLIDER

UNLOCK ANY TRAIL. ANYTIME.



SILVERBACK BIKES



OVERVIEW

Slider's Aluminium frame tubeset encompasses a solid rear triangle with a more forgiving front triangle tubeset, giving excellent ride feel, control and all day enduro riding comfort. The geometry used helps maintain a balanced posture for both uphill traction and downhill control with a medium reach and balanced head tube angle. Frame designed with short seat tube to allow for long travel dropper post use and great standover clearance.

Frame allows for two small water bottles to be carried on the frame, one inside the front triangle and one below the down tube. Single pivot design provides excellent tracking, trail feedback and longevity of pivots. Suspension kinematics uses a linear leverage ratio to make the bike less sensitive to aggressive rider movement, making the handling more consistent for performance riding.





SLIDER



SLIDER MS

KEY FEATURES: SLIDER

- 6061-T6 Alloy Trail/Enduro Frame. True single pivot design, 150mm Rear Travel, BSA Bottom Bracket, Boost 148mm thru-axle, can fit 160mm forks.
- 29" Boost 12x148mm.
- 150mm Suspension forks.
- Hydraulic disc brakes.
- Maxxis Assegai/Minion 29x2.5" Tubeless Tyres
- Custom SUNRingle/Surface wheelset, 32H Asymmetric rims, Tubeless.
- Surface Dropper on all models.
- Weight: 14.8 - 15.1 kg

SLIDER

COLOUR: PRISM SILVER

SPECIFICATION

Frame	New Slider Hydro-formed 6061-T6 Alloy Frame. 150mm travel, Boost 148mm thru-axle, tapered headtube.
Headset	Steel Semi-Integrated, ZS44/28.6 ZS56/40
Frame Axle Spacing	148x12mm
Axle Specification	181x12mm P1.75
Hanger Type	Hanger 3
Fork	Marzocchi Bomber Z2 Air, 150mm travel, 15x110mm Boost
Fork Travel	150mm
Rear Shock	SR Suntour RS18 EDGE TR LOR, 185 X 55mm, Air
Rear Suspension Travel	150mm
Shock Mounting	Body: Trunnion, M10x54mm, Shaft: Standard, 8x20mm
Eye-to-Eye x Stroke	185x55mm
Wheelset	SUNringlé Custom Wheelset
Hubs	F: 15x110mm, 6 Bolt, R: 148x12mm, 6-Bolt
Rims	SUNringlé Duroc 35, STR Tubeless, 32mm Internal Width
Tyres	Maxxis Assegai/Minion DHR11 29x2.5/2.4", 120TPI, EXO, Tubeless
Max Tyre Size	2.5"
Crankset	Alloy, 32T, 175mm, External BB
Max Chainring Size	32T
Bottom Bracket & Type	BSA73
Shifter(s)	R: Shimano Deore SL-M5100-R, 11 Speed, Rapidfire Plus
Rear Derailleur	Shimano Deore RD-M5100, 11 Speed
Cassette	Shimano Deore CS-M5100, 11 Speed, 11-51T
Chain	KMC X11-1, 11 Speed
Brakes	Shimano MT200 Hydraulic Disc, Resin Pads
Rotors	Shimano SM-RT10 180mm, 6 bolt
Handlebar	SURFACE Alloy, 31.8mm, 760mm, 9° Backsweep, 20mm Rise
Stem	SURFACE Alloy, 31.8mm, Rise 3°
Seatpost	SURFACE Dropper with Lever, 30.9mm
Bike Weight	14.8 kg



SLIDER MS

COLOUR: PRISM GREY



SPECIFICATION

Frame	New Slider Hydro-formed 6061-T6 Alloy Frame. 150mm travel, Boost 148mm thru-axle, tapered headtube.
Headset	Steel Semi-Integrated, ZS44/28.6 ZS56/40
Frame Axle Spacing	148x12mm
Axle Specification	181x12mm P1.75
Hanger Type	Hanger 3
Fork	SR Suntour Durolux 36, 150mm Travel, Boost, 29", Air
Fork Travel	150mm
Rear Shock	SR Suntour RS19 EDGE TR LOR, 185 X 55mm, Air
Rear Suspension Travel	150mm
Shock Mounting	Body: Trunnion, M10x54mm, Shaft: Standard, 8x30mm
Eye-to-Eye x Stroke	185x55mm
Wheelset	Surface Custom
Hubs	F: 15x110mm, 6 Bolt, R: 148x12mm, 6-Bolt
Rims	SUNringlé Duroc 35, STR Tubeless, 32mm Internal Width
Tyres	Maxxis Assegai/Minion DHR II 29x2.5/2.4", 120TPI, EXO, Tubeless
Max Tyre Size	2.5"
Crankset	Alloy 32T Narrow-wide
Max Chainring Size	32T
Bottom Bracket & Type	BSA73
Shifter(s)	R: Microshift Xpress Plus, 11speed
Rear Derailleur	Microshift XLE RD-M665L, 11spd, Active Motion RD+ with clutch
Cassette	Microshift Cassette, 11spd, 11-46T
Chain	KMC X11-1, 11 Speed
Brakes	Tektro MD-M275 Hydraulic Disc
Rotors	Tektro 180mm, 6 Bolt
Handlebar	SURFACE Alloy, 31.8mm, 760mm, 9° Backsweep, 20mm Rise
Stem	SURFACE Alloy, 31.8mm, Rise 3°
Seatpost	SURFACE Dropper with Lever, 30.9mm
Bike Weight	15.1 kg



POP GEOMETRY

Slacker head angles and a longer wheelbase, along with other geometry and longer-travel suspension allow for a bike that is more capable and forgiving on the downhill, without sacrificing uphill ability in the process.



1X SPECIFIC DRIVETRAIN (32T)

Slider, Shimano: 11-51T,
11-13-15-18-21-24-28-33-39-45-51T

Slider MS, Microshift: 11-46T,
11-13-15-18-21-24-28-32-36-40-46



QUALITY SUSPENSION

Designed for a 150-160mm travel fork to soak up big hits and drops.



SHOCK MOUNT INTEGRATION

Lower shock mount integrated into down tube for excellent strength and helps lower the centre of gravity for performance handling.



SINGLE PIVOT SUSPENSION

Single pivot design provides excellent tracking, trail feedback and longevity of pivots. Suspension kinematics uses a linear leverage ratio to make the bike less sensitive to aggressive rider movement, making the handling more consistent for performance riding. Offers 150mm of travel.

Single pivot frame design relies on two large 6903 maximum fill bearings, creating a stiff and accurate suspension system using two solid triangular frame structures, and also making the bike easy to maintain as there are minimal moving parts.

Trunnion shock mount pivot uses multiple 6900 bearings with maximum count fill for best durability and smoothness. Two bearings either side ensure further supple suspension action and maximum durability.



125-200mm COMPATIBLE DROPPER POSTS

Get low & stable on downhills!

Slider has a short seat tube for longer dropper posts (125-200mm).

Neat internal-routed cable management.



LONGER STROKE

The long 55mm stroke shock improves damping sensitivity and control, and together with the linear leverage ratio of the single pivot suspension system, this allows large bumps to be absorbed easily and the bike still remains upright through the mid-stroke, helping to keep on top of the terrain.



INTERNAL CABLE ROUTING

Cable routing is quick and easy, making installation a breeze. Internal routing keeps the bike neat and clutter free. It also means that cables are protected from impact damage. Full length cable housing also means less dirt contaminates the system and therefore less maintenance.



ASYMMETRIC RIMS

Better stress triangulation/balance between both sides, improves durability.

2.5" TYRE CLEARANCE

Uncompromised tyre choices, to match the terrain demands.

TUBELESS READY

All Slider models are tubeless ready

BOOST THRU-AXLE

Slider features BOOST thru-axles front & rear



TWO WATERBOTTLE MOUNTS

When it comes to water bottles, two is definitely better than one.

EXTRAS



Downtube protector included on frame to reduce rock strike damage to paint and frame in critical area and also helps to reduce noise of impacts.

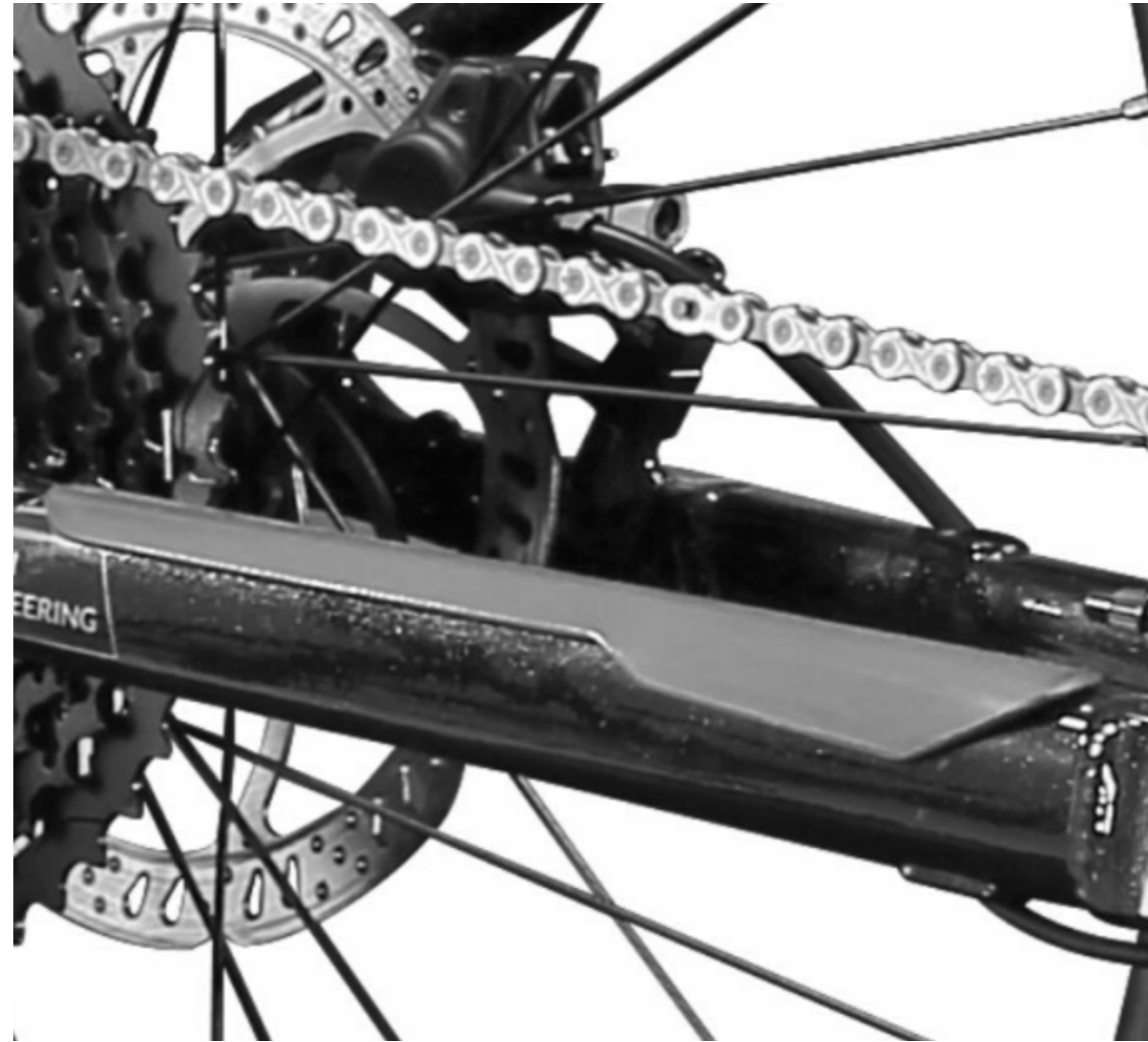

Silverback chainstay protector included to help dampen chain slap on chainstay and protect tubing.



Integrated 18mm kickstand mount for best secure attachment.

TRAIL BIKE CAPABILITIES.

SUSPENSION KINEMATICS

The linear leverage ratio ensures the long stroke shock gets to full travel on rough terrain and allows the rider to have consistent damping throughout the whole shock stroke. This linear feeling is more like a coil shock and allows the rider to tune their suspension more accurately for different course terrain as it responds very well to shock setup, helping to get the most speed on varying enduro tracks.

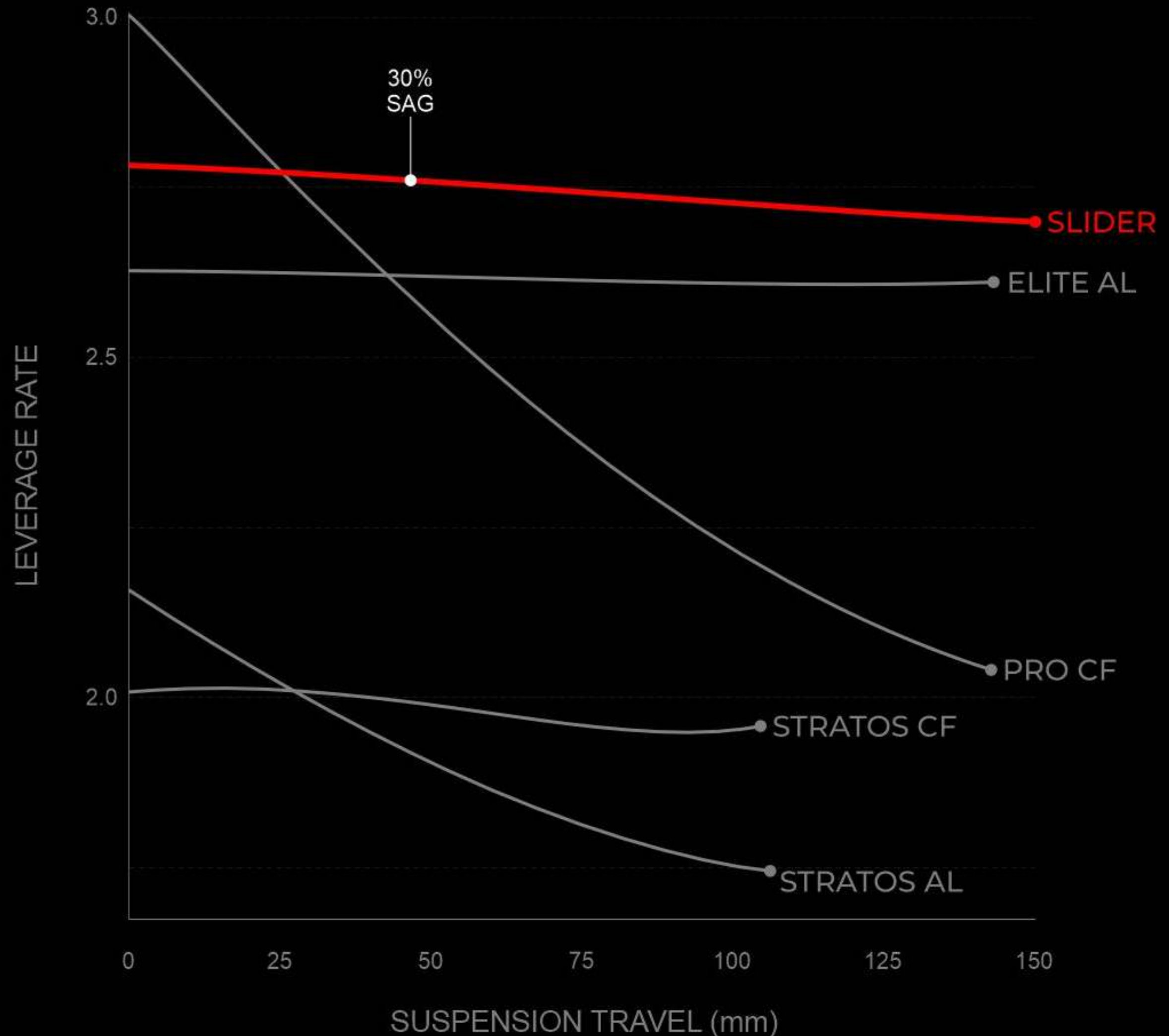

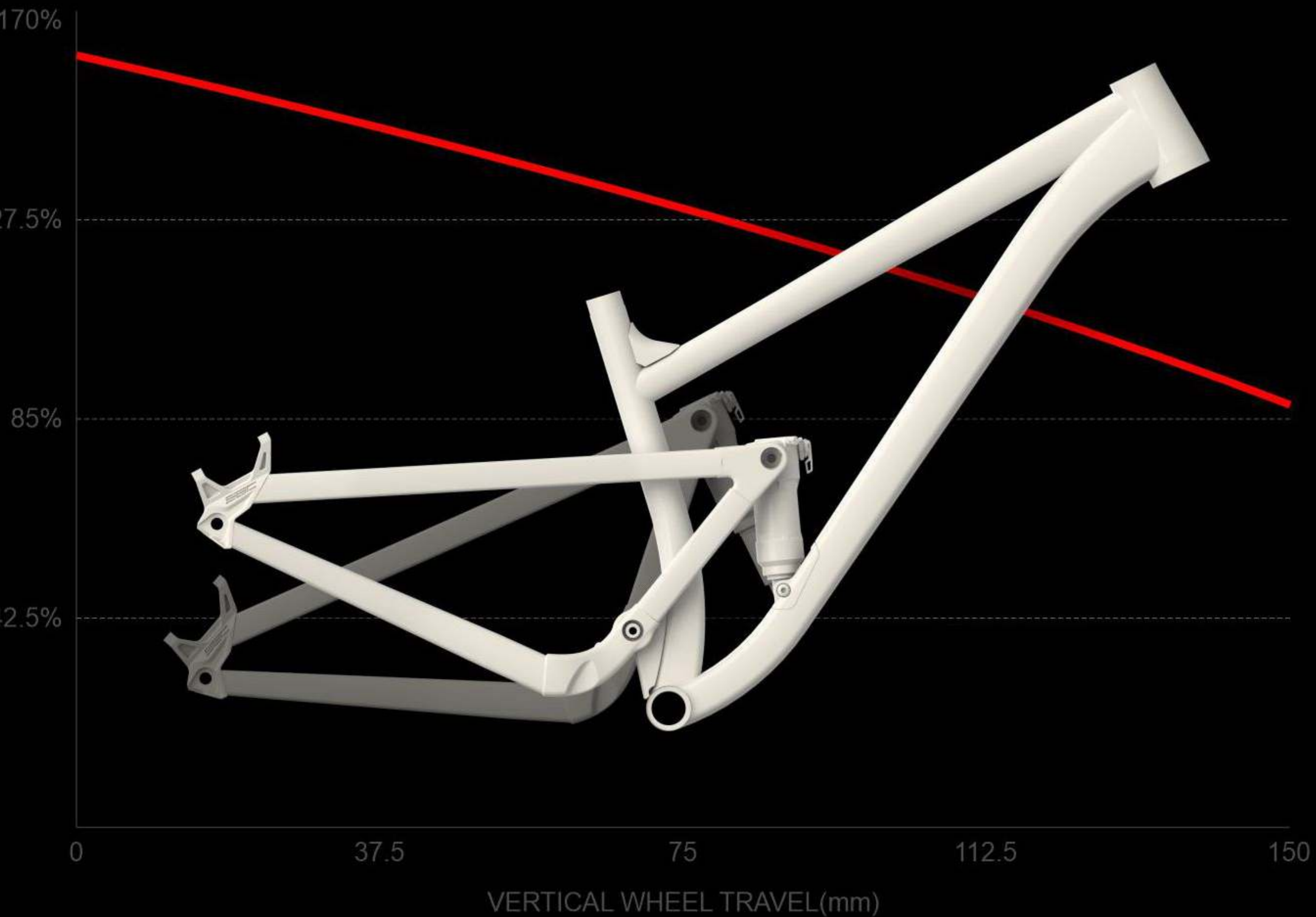

SUSPENSION ANTI-SQUAT

←

The high anti-squat start helps the bike to have a crisp and responsive feel during the climbs and flat out technical singletrack racing. It then backs off in the mid-stroke area to help the bike absorb rough terrain while pedaling, but still allowing a responsive forward motion at every crank movement, yet not so much as to overly stiffen the suspension.

GEOMETRY.

The geometry uses longer reach and slack head tube angle to improve handling stability and control in steep terrain, and feel at home on fast open flow tracks. Aimed at both enduro performance riding and to bring comfort to all day rides, we designed this single pivot suspension frame to bring a direct feeling ride to our mid travel trail bike for all occasions.

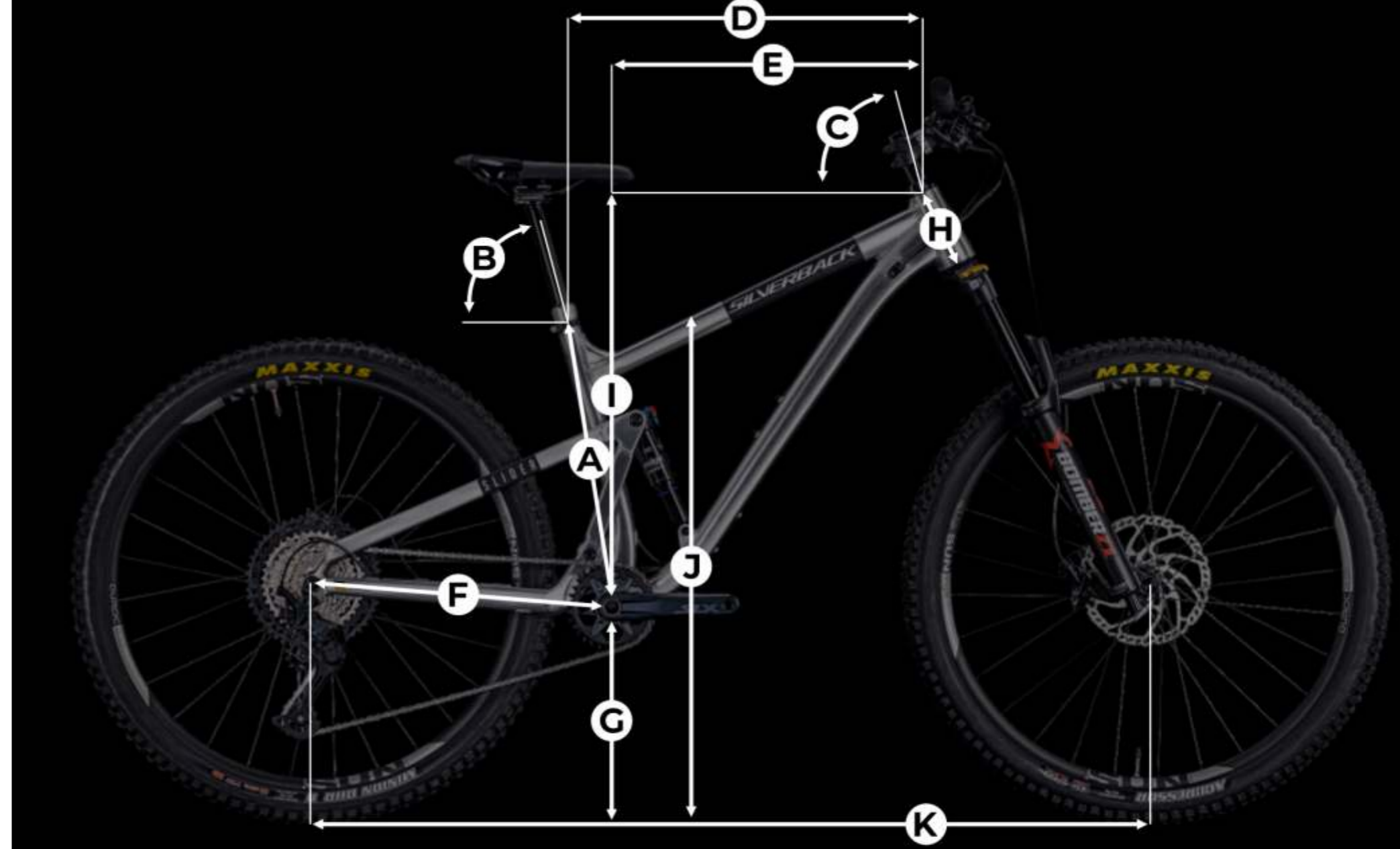

MAP	TYPE (mm unless specified)	S	M	L	XL
	RIDER HEIGHT (cm)	154-170	170-180	180-190	188-210
	RIDER INSEAM (cm)	70-77	77-82	82-86	85-95
A	SEAT TUBE C/T	390	410	435	460
B	SEAT TUBE ANGLE	78°	78°	78°	78°
C	HEAD TUBE ANGLE	64°	64°	64°	64°
D	TOP TUBE	571	586	608	631
E	REACH	440	455	475	495
F	CHAINSTAY LENGTH	455	455	455	455
G	BB HEIGHT	341	341	341	341
H	HEAD TUBE LENGTH	110	110	120	130
I	STACK	623	623	632	641
J	STANDOVER	810	822	819	850
K	WHEELBASE	1230	1245	1269	1289

AGGRESSIVE TRAIL / ENDURO.

SINGLE PIVOT ALLOY FRAME

Frame design uses two solid triangles for ultimate strength to weight to stiffness ratio, and this also allows the single pivot suspension to have great trail feedback and sensitivity to terrain undulations.

POP GEOMETRY

POP Geometry – Balanced posture to maintain traction uphill and control downhill.

150/150 MM FRONT/REAR TRAVEL

Longer travel to handle big hits, rail corners, and rip down the mountain faster.

2.5" TYRE CLEARANCE

Uncompromised tyre choices, to match the terrain demands.



Silverback Slider - Exploded view of parts

Headset: Semi-Integrated ACB 1-1/8" to 1.5"
Upper cup 44mm / Lower cup 56mm

#	Part Description	Qty
1	Solid Rear Triangle	1
2	Front Triangle - size specific	1
3	Silverback SBC Hanger	1
4	M4 Countersunk bolt	1
5	Main Pivot bolt set (M&F)	1
6	Main Pivot spacer	1
7	6903-2RS MAX bearings	2
8	Lower shock mount bolt set (M&F)	1
9	Trunnion mount bolt	2
10	6900-2RS MAX bearings	4
11	Trunnion mount washers	4
12	DT cable plug disc side	1
13	DT cable plug drive side	1
14	Double cable guide cover	2
15	12mm through axle: 181mm x 1.75TP	1
16	Chainstay protector	1
17	Down Tube protector	1

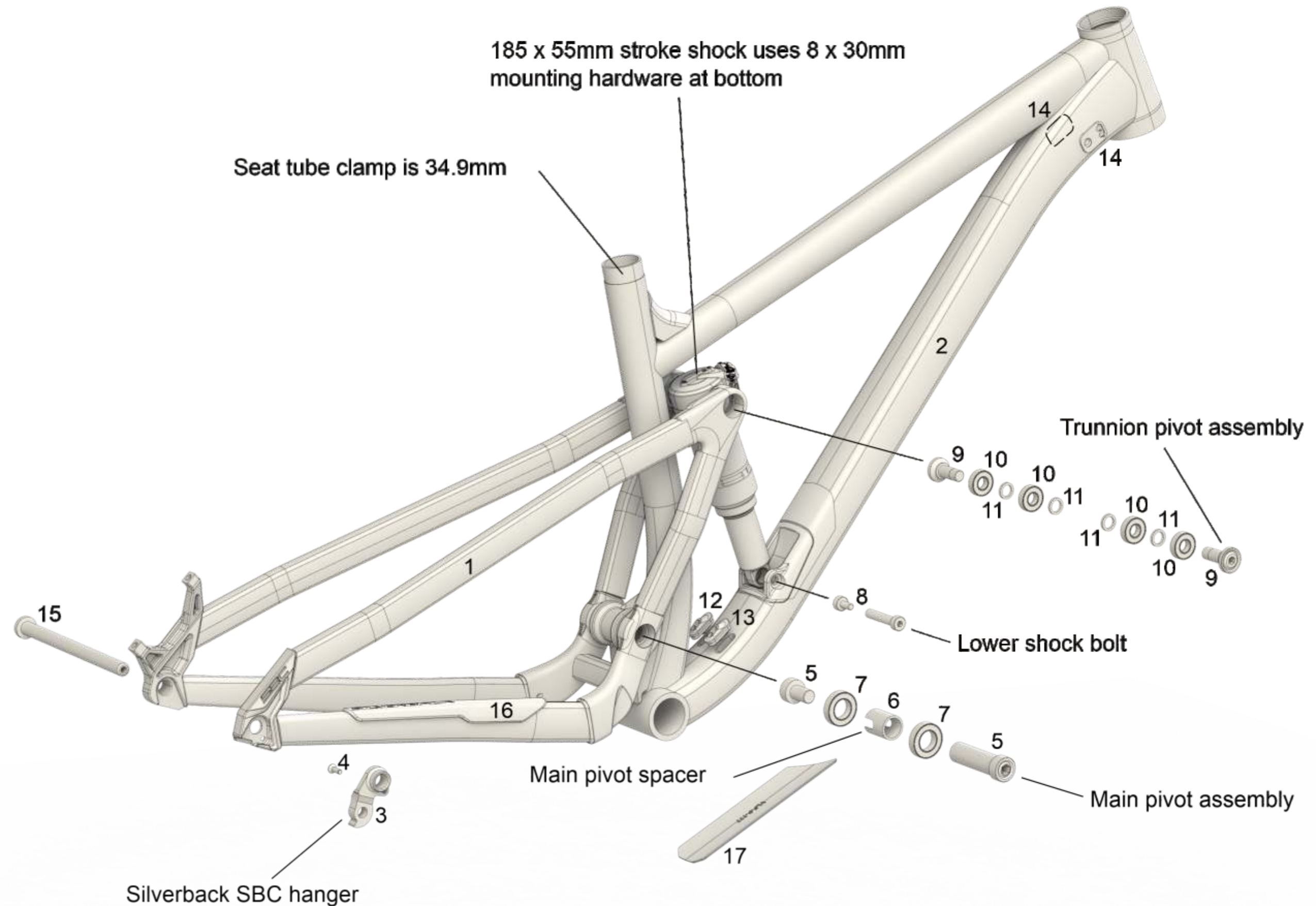

PLANET EARTH
PLEDGE



SILVERBACK
PROTECTING THE PLANET
& CARING FOR PEOPLE



DESIGN
ENGINEERING



BRAND FILMS.

[See for yourself](#)



Silverback | Slider BURST suspension kinematics - [CHECK IT OUT](#)

RIDE RATE REVIEW: Silverback Slider LT | Mountain Bike Review. [CHECK IT OUT](#)

SILVERBACK BIKES - Silverback Slider & Sprada - IDS Technology. [CHECK IT OUT](#)

RIDE RATE REVIEW: Silverback Slider LT Enduro bikecheck. [CHECK IT OUT](#)

MTBR: SILVERBACK SLIDER 27.5 FULL SUSPENSION. [CHECK IT OUT](#)

THE ONE K - Silverback Bikes SLIDER. [CHECK IT OUT](#)

[BIKE HUB Forum: Slider](#). [CHECK IT OUT](#)

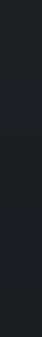
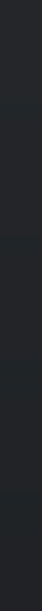

RESOURCE CENTRE:

ACCESS TO THESE AND MORE THROUGH THE B2B ITS PORTAL:

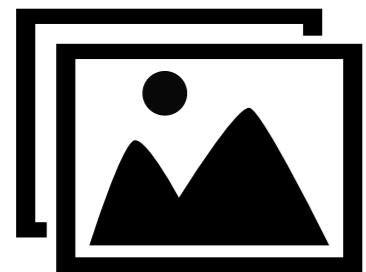

LIFESTYLE IMAGES

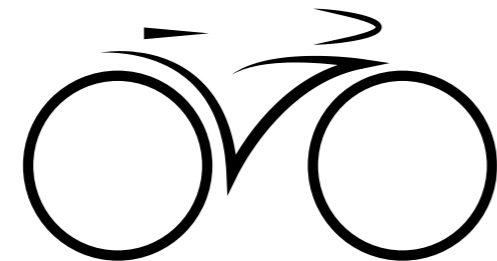

PRODUCT IMAGES

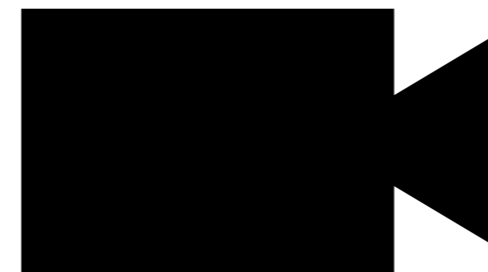

VIDEOS

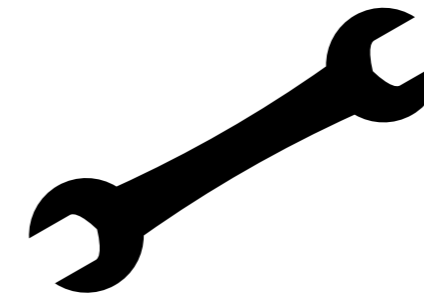

SPEC DOCUMENT

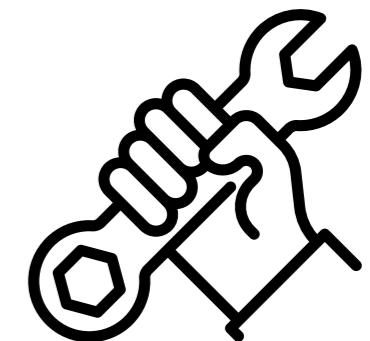

SPARE PARTS

SILVERBACK BIKES



#BORNTOBEEFAST

