



SILVERBACK BIKES



PROGRESSIVE THINKING IN DESIGN

#BORNTOBEEFAST

AN ENGINEERING MASTERCLASS.



#BORNTOBEBFAST

ELITE AL

ENGINEERED ELECTRIC DESIGN



SILVERBACK BIKES



OVERVIEW

The Elite AL e-Bike allows for riders to tackle steeper and more technical terrain with assisted power, and helps the rider stay comfortable with 29" wheels and long travel suspension to absorb the terrain.

Single pivot one-piece solid rear triangle for precise suspension movement and increased lateral stiffness is ideal for electric power assisted full suspension bikes to tackle heavy terrain with an aggressive riding style.

A powerful Shimano EP8 electric motor paired with a large 36V, 720Wh internal battery makes mole hills of mountains. The battery charges to 80% in 3 hours, and the Elite AL has a range from 30 - 100km depending on the assist levels and terrain you are riding.





ELITE AL 1



ELITE AL 2

KEY FEATURES: ELITE AL

- Alloy Dual Suspension for Shimano EP8 and 720Wh battery. Trail/Enduro E-Bike with 145mm progressive frame travel. Designed to be light, nimble and easy to maintain.
- 29" Boost 12x148mm.
- 150mm Suspension forks.
- Hydraulic disc brakes.
- Maxxis Assegai/Minion 29x2.5" Tubeless Tyres
- Custom SUNRingle wheelsets, 32H, Tubeless.
- Surface Dropper on all models.
- Weight: 24-24.6 kg

ELITE AL 1

COLOUR: PRISM SILVER



SPECIFICATION

Frame	New Slider Hydro-formed 6061-T6 Alloy Frame. Boost 148mm thru-axle, tapered headtube.
Headset	Token TK1156SP S-Box Headset (IS52/28.6 IS52/40)
Frame Axle Spacing	148x12mm
Axle Specification	181x12mm P1.75
Hanger Type	Hanger 3
Fork	Fox Performance 36 Float, GRIP, 150mm, 44mm Offset, Air
Fork Travel	150mm
Rear Shock	RockShox Deluxe Ultimate RCT Linear Air Can 0 Neg 3 Pos
Rear Suspension Travel	145mm
Shock Mounting	Air Can: Trunnion, M10x54mm, Shaft: Standard, 8x30mm
Eye-to-Eye x Stroke	185x55mm
Wheelset	SUNringlé Custom Wheelset
Hubs	F: SUNringlé SRC 110x15, 6 Bolt; R: SUNringlé SRC 148x12, 6 Bolt
Rims	SUNringlé Duroc 35, STR Tubeless, 32mm Internal Width
Tyres	Maxxis Assegai/Minion DHRII 29x2.5/2.4", 120TPi, 3C, Tubeless
Max Tyre Size	2.5"
Crankset	Shimano FC-EM600 Crank Arm Set, 170mm
Max Chainring Size	38T
Bottom Bracket & Type	Included with Mid-Drive Motor
Shifter(s)	L: NIL; R: SRAM GX Eagle Lunar
Rear Derailleur	SRAM GX Eagle Lunar
Cassette	SRAM GX Eagle 10-52T
Chain	SRAM GX Eagle, Power Lock 12 Speed
Brakes	SRAM Code R
Rotors	SRAM Centerline 200/180mm
Handlebar	SURFACE Trail 35mm Handlebar, Backsweep 6°, Rise 12mm
Stem	SURFACE Alloy, 35mm, Rise 7°
Seatpost	SURFACE Dropper with Lever, 30.9mm
Bike Weight	24 kg

ELITE AL 2

COLOUR: MILITARY GREEN



SPECIFICATION

Frame	New Slider Hydro-formed 6061-T6 Alloy Frame. Boost 148mm thru-axle, tapered headtube.
Headset	Token TK1156SP S-Box Headset (IS52/28.6 IS52/40)
Frame Axle Spacing	148x12mm
Axle Specification	181x12mm P1.75
Hanger Type	Hanger 3
Fork	Marzocchi Bomber Z2 Air, 150mm, 110mm Boost, Thru Axle
Fork Travel	150mm
Rear Shock	RockShox Deluxe Select+ RT, Linear Air Can 0 Neg 3 Pos
Rear Suspension Travel	145mm
Shock Mounting	Air Can: Trunnion, M10x54mm, Shaft: Standard, 8x30mm
Eye-to-Eye x Stroke	185x55mm
Wheelset	Surface Custom
Hubs	F: SUNringlé SRC 110x15, 6 Bolt; R: SUNringlé SRC 148x12, 6 Bolt
Rims	SUNringlé Duroc 35, STR Tubeless, 32mm Internal Width
Tyres	Maxxis Minion DHF 29x2.5", 60TPi, EXO, Tubeless Ready
Max Tyre Size	2.5"
Crankset	Shimano FC-EM600 Crank Arm Set, 170mm
Max Chainring Size	38T
Bottom Bracket & Type	Included with Mid-Drive Motor
Shifter(s)	L: NIL; R: Sram SX Eagle Trigger
Rear Derailleur	SRAM SX Eagle
Cassette	SRAM SX Eagle, 11-50T
Chain	SRAM SX Eagle Chain
Brakes	SRAM Level Disc
Rotors	SRAM Centerline 200/180mm
Handlebar	SURFACE Trail 35mm Handlebar, Backsweep 6°, Rise 12mm
Stem	SURFACE Alloy, 35mm, Rise 7°
Seatpost	SURFACE Dropper with Lever, 30.9mm
Bike Weight	24.6 kg



POP GEOMETRY

Slacker head angles and a longer wheelbase, along with other geometry and longer-travel suspension allow for a bike that is more capable and forgiving on the downhill, without sacrificing uphill ability in the process.



POWERFUL SHIMANO MOTOR

S-Electro Elite AL is designed around a Shimano Steps EP8, 85 Nm mid-drive motor. Shimano's EP8 motor offers excellent all-round performance which is perfect for E-MTB riding. With its smooth torque support, the ride feel is simply incredible.



HIGH VOLUME 720 Wh BATTERY

S-Electro Elite AL is paired to a high capacity 720Wh internal battery giving the Steps an unrivalled range of pedal assistance. This battery is easy-to-charge and is designed for maximum convenience in your day-to-day riding routine. Lock up your bike worry free – the battery is key removable only. Charging is easy on or off the bike – turn the key, pop it out, and plug in the charger delivered with your bike.



INFORMATIVE DISPLAY

Depending on S-Electro Elite AL Model, it offers a very informative display for intuitive operation as well as an ergonomic switch position especially developed for E-MTB.

CONVENIENT POWER

Easy access to engage e-bike drive

BATTERY SECURITY

Protects against theft





1X SPECIFIC DRIVETRAIN (32T)

AL 1: 10-12-14-16-18-21-24-28-32-36-42-52T

AL 2: 11-13-15-17-19-22-25-28-32-36-42-50T

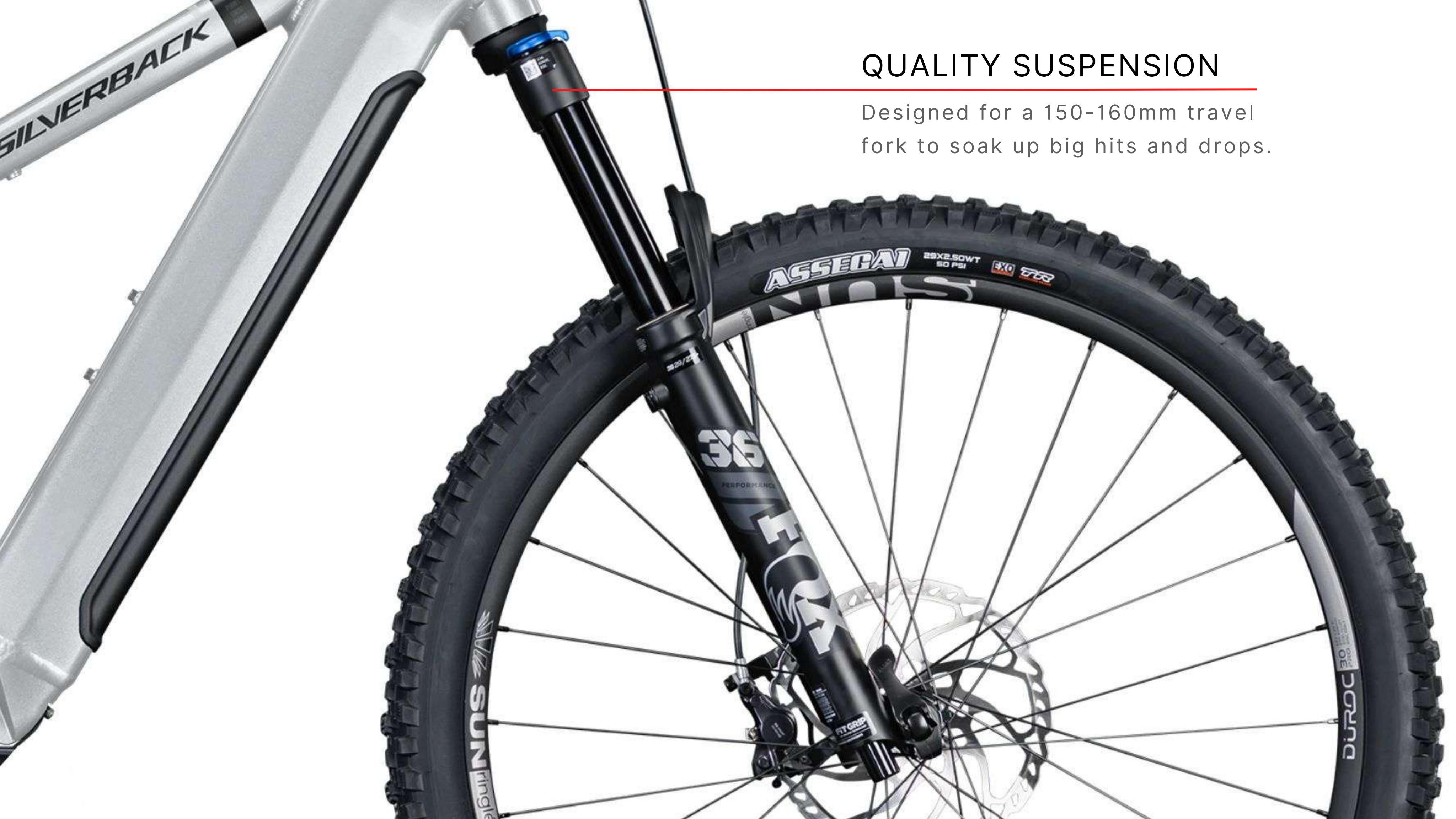

QUALITY SUSPENSION

Designed for a 150-160mm travel fork to soak up big hits and drops.



SINGLE PIVOT SUSPENSION

Single pivot design provides excellent tracking, trail feedback and longevity of pivots. Suspension kinematics uses a linear leverage ratio to make the bike less sensitive to aggressive rider movement, making the handling more consistent for performance riding. Offers 145mm of travel.

Single pivot frame design relies on two large 6903 maximum fill bearings, creating a stiff and accurate suspension system using two solid triangular frame structures, and also making the bike easy to maintain as there are minimal moving parts.

Trunnion shock mount pivot uses multiple 6900 bearings with maximum count fill for best durability and smoothness. Two bearings either side ensure further supple suspension action and maximum durability.

A close-up photograph of a bicycle's seat and seatpost assembly. The seat is black with "SURFACE" written on it. The seatpost is black and features a silver-colored clamp with "ESR" branding. The frame is a matte olive green color with "SILVERBACK" printed on the top tube. A red horizontal line is drawn across the image, starting from the left edge and ending at the seatpost. In the bottom left corner, a portion of a black tire is visible with "EXO" and "50 PSI" markings.

125-200mm COMPATIBLE DROPPER POSTS

Get low & stable on downhills!

Elite AL has a short seat tube for longer dropper posts (125-170mm).

Neat internal-routed cable management.



LONGER STROKE

The long 55mm stroke shock improves damping sensitivity and control, and together with the linear leverage ratio of the single pivot suspension system, this allows large bumps to be absorbed easily and the bike still remains upright through the mid-stroke, helping to keep on top of the terrain.

A close-up photograph of a bicycle's headset and handlebars. The frame is silver, and the handlebars are black. A black cable housing is routed internally through the frame, visible as a white braided section. The handlebars have a blue cap on the right side. The text 'INTERNAL CABLE ROUTING' is overlaid on the left side of the image.

INTERNAL CABLE ROUTING

Cable routing is quick and easy, making installation a breeze. Internal routing keeps the bike neat and clutter free. It also means that cables are protected from impact damage. Full length cable housing also means less dirt contaminates the system and therefore less maintenance.



2.5" TYRE CLEARANCE

Uncompromised tyre choices, to match the terrain demands.

TUBELESS READY

All Slider models are tubeless ready

BOOST THRU-AXLE

BOOST thru-axles front & rear

EXTRAS



S-Electro Elite AL charging port features a compact, semi-integrated design for charging the frame-integrated 720Wh battery.

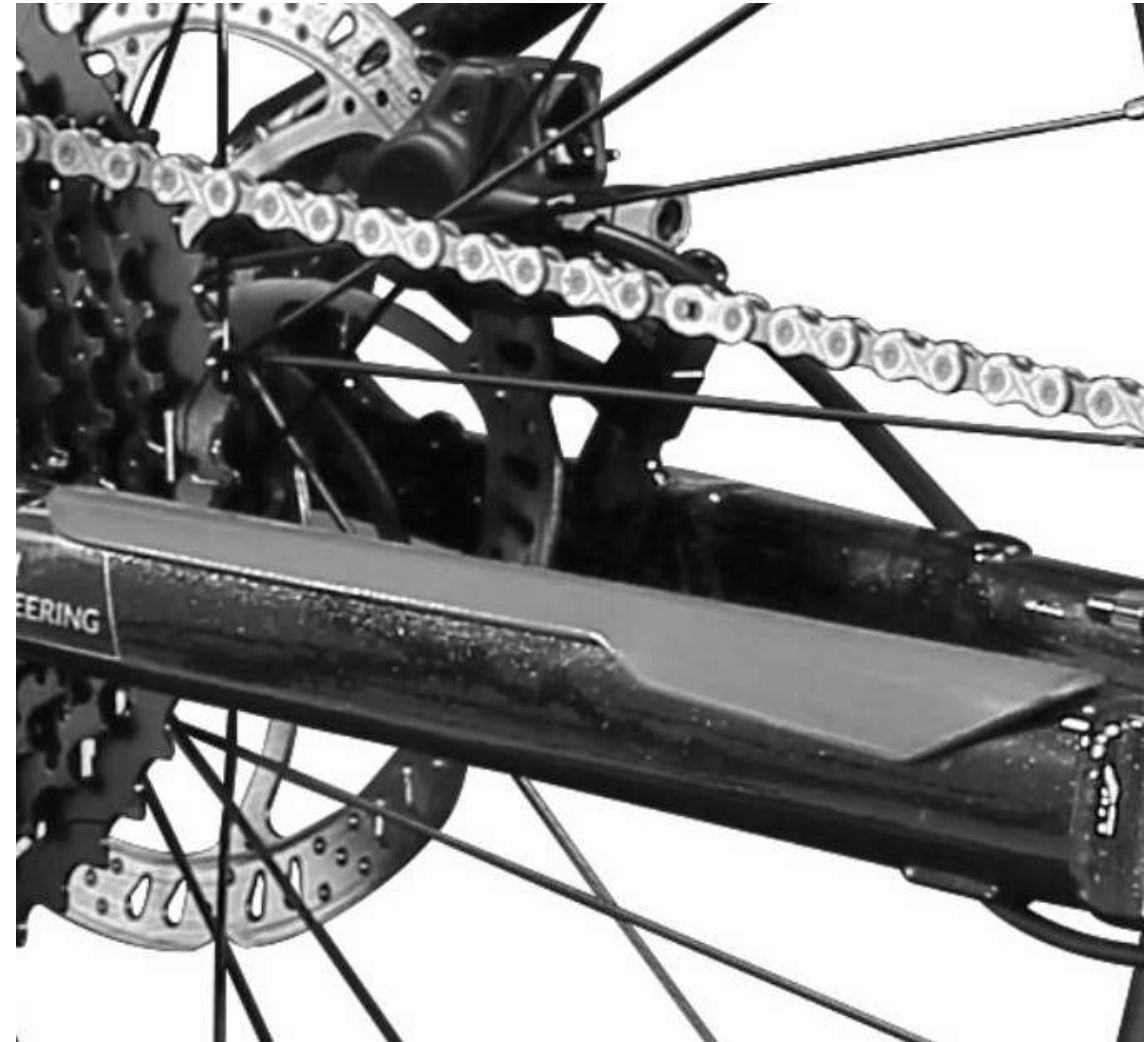

Silverback chainstay protector included to help dampen chain slap on chainstay and protect tubing.



Integrated 18mm kickstand mount for best secure attachment.

TRAIL BIKE CAPABILITIES.

SUSPENSION KINEMATICS

The linear leverage ratio ensures the long stroke shock gets to full travel on rough terrain and allows the rider to have consistent damping throughout the whole shock stroke. The linear ratio allows for a consistent feeling and when combined with the assisted motor power, it helps to give the rider a solid platform to ride with no matter the bump size.

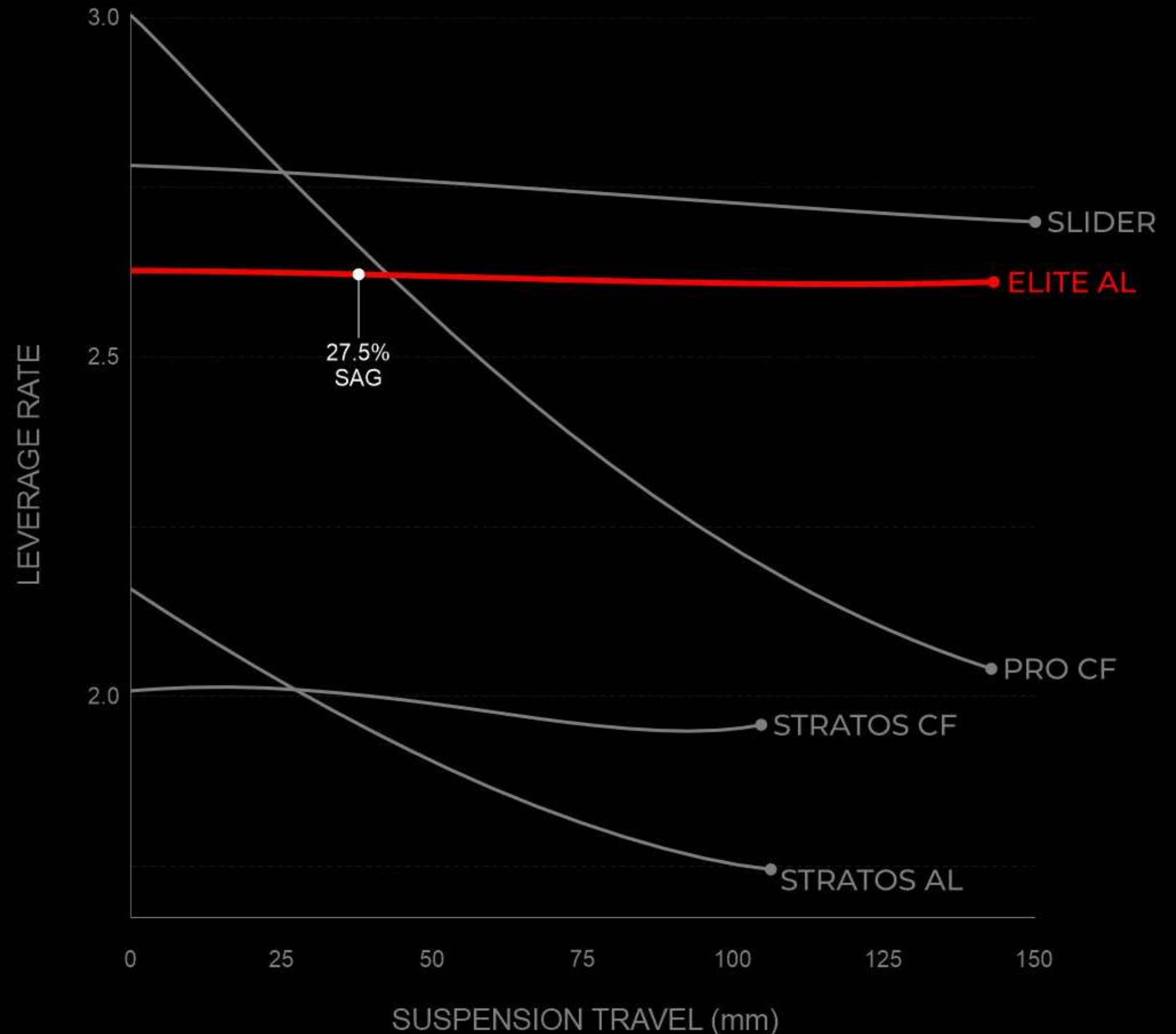

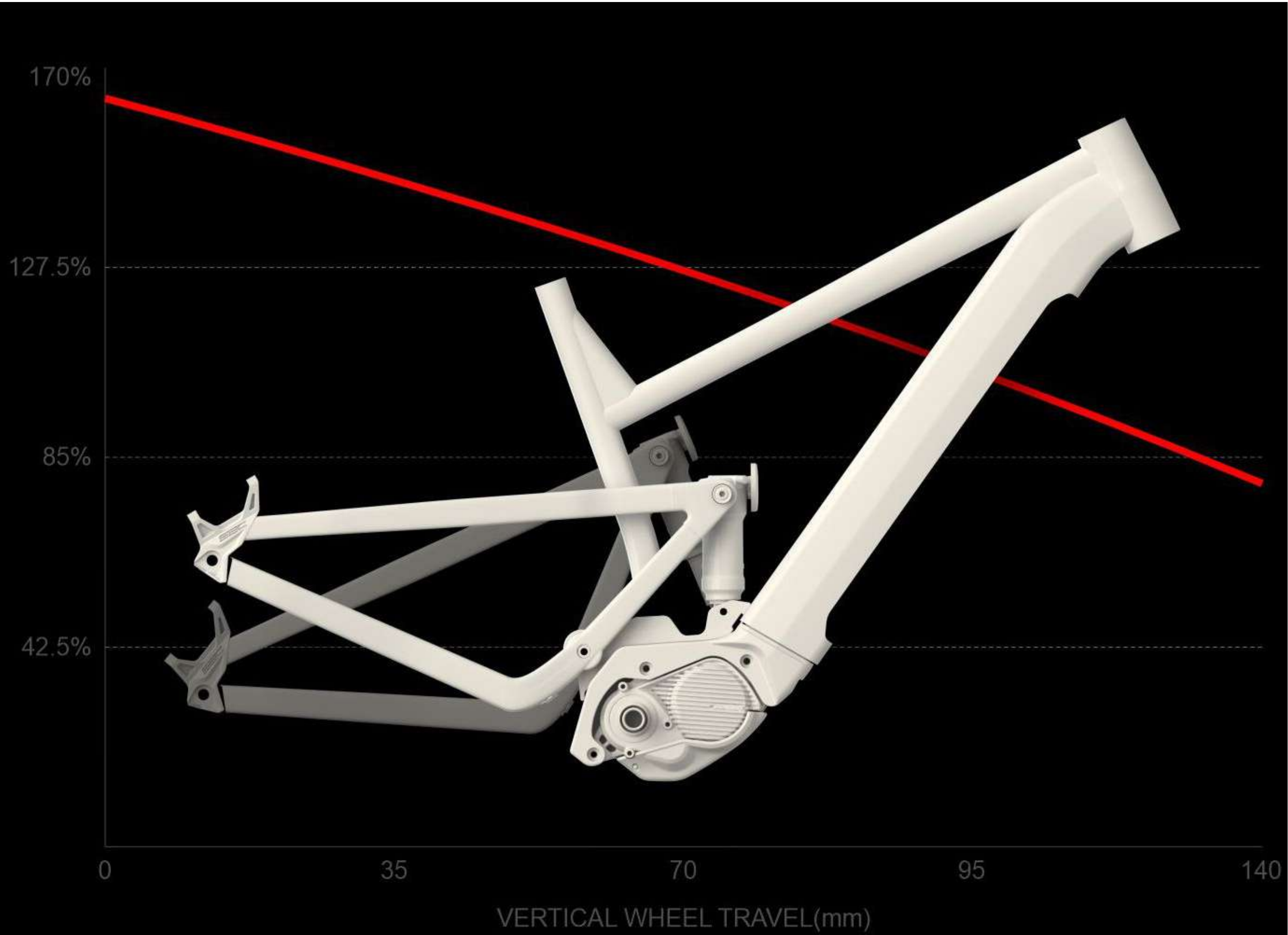

SUSPENSION ANTI-SQUAT

←

The high anti-squat figure helps to keep the bike articulate in its movements under assisted power and with soft suspension settings for all day comfort. The bike responds well to any crank movement in any gear combination and allows rider to use large front chainring without losing this responsiveness.

GEOMETRY.

The geometry uses longer reach and slack head tube angle to improve handling stability and control in steep terrain, and feel at home on fast open flow tracks. Aimed at both enduro performance riding and to bring comfort to all day rides, we designed this single pivot suspension frame to bring a direct feeling ride to our mid travel trail bike for all occasions.

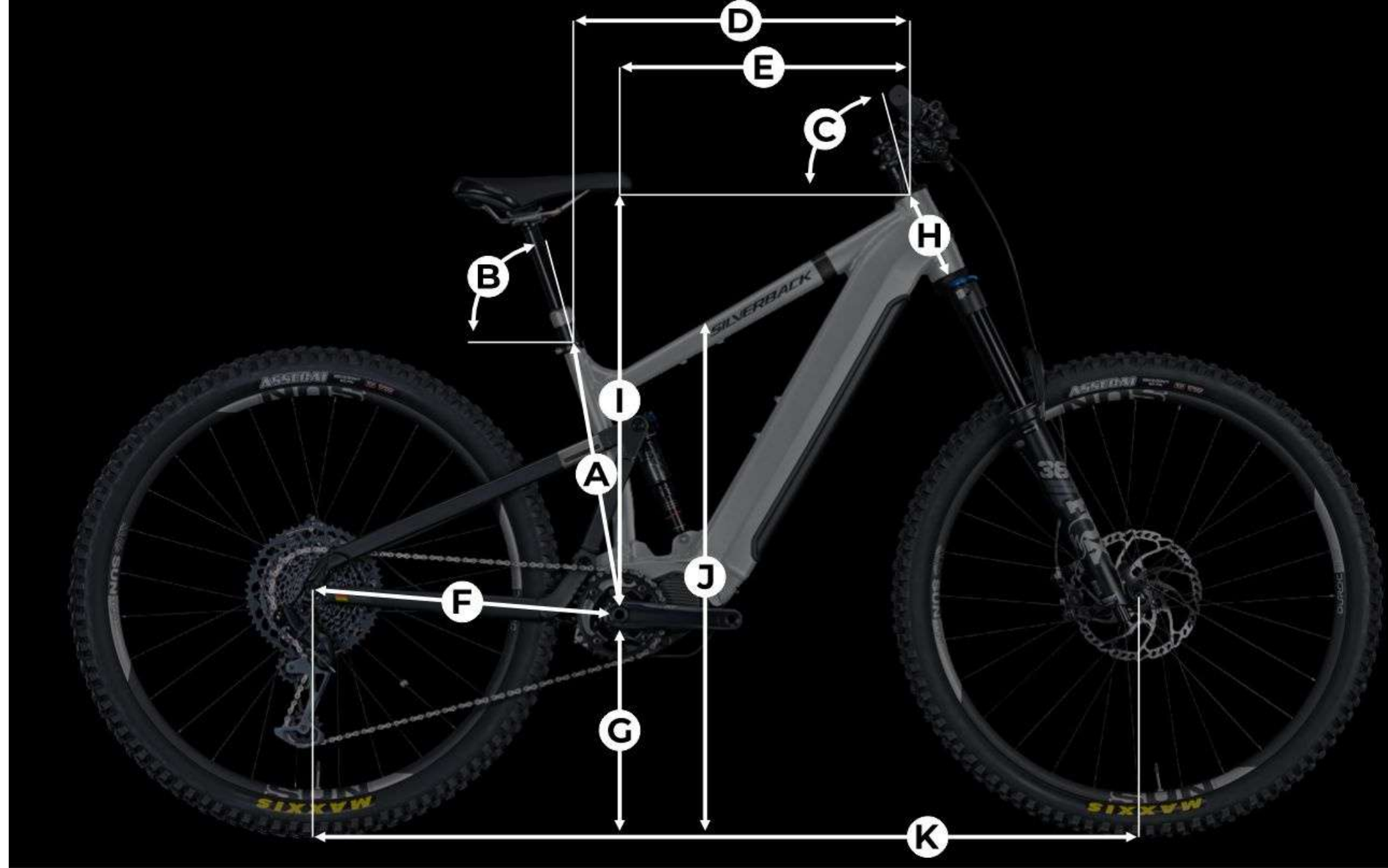

MAP	TYPE (mm unless specified)	S	M	L	XL
	RIDER HEIGHT (cm)	160-173	170-180	180-190	190-200
	RIDER INSEAM (cm)	73-79	77-82	82-86	86-91
A	SEAT TUBE C/T	390	420	450	480
B	SEAT TUBE ANGLE	76.5°	76.5°	76.5°	76.5°
C	HEAD TUBE ANGLE	64.5°	64.5°	64.5°	64.5°
D	TOP TUBE	521	548	583	612
E	REACH	430	450	478	500
F	CHAINSTAY LENGTH	467	467	467	467
G	BB HEIGHT	347	347	347	347
H	HEAD TUBE LENGTH	120	125	135	135
I	STACK	626	631	640	640
J	STANDOVER	805	825	847	866
K	WHEELBASE	1229	1251	1283	1305

AGGRESSIVE TRAIL / ENDURO

E-POWER

A powerful Shimano EP8 electric motor delivers up to 85Nm torque or up to 25km/h. Paired with a large 720Wh internal battery that delivers up to >100km or 4.8hrs of riding.

SINGLE PIVOT ALLOY FRAME

Frame design uses two solid triangles for ultimate strength to weight to stiffness ratio, and this also allows the single pivot suspension to have great trail feedback and sensitivity to terrain undulations.

POP GEOMETRY

POP Geometry – Balanced posture to maintain traction uphill and control downhill.

150/145 MM FRONT/REAR TRAVEL

Longer travel to handle big hits, rail corners, and rip down the mountain faster.

2.5" TYRE CLEARANCE

Uncompromised tyre choices, to match the terrain demands.



Silverback Selectro Elite AL- Main Exploded view

Headset: Token TK1156SP S-BOX
(IS52/28.6 / IS52/40)

#	Part Description	Qty
1	Solid Rear Triangle	1
2	Front Triangle - size specific	1
3	Silverback SBC Hanger	1
4	M4 Countersunk bolt	1
5	Main Pivot bolt set (M&F)	1
6	Main Pivot spacer	1
7	6903-2RS MAX bearings	2
8	Lower shock mount bolt set (M&F)	1
9	Trunnion mount bolt	2
10	6900-2RS MAX bearings	4
11	Trunnion mount washers	4
12	Main pivot washer	2
13	Motor mounting bolts	6
14	12mm through axle: 181mm x 1.75TP	1
15	Chainstay protector	1

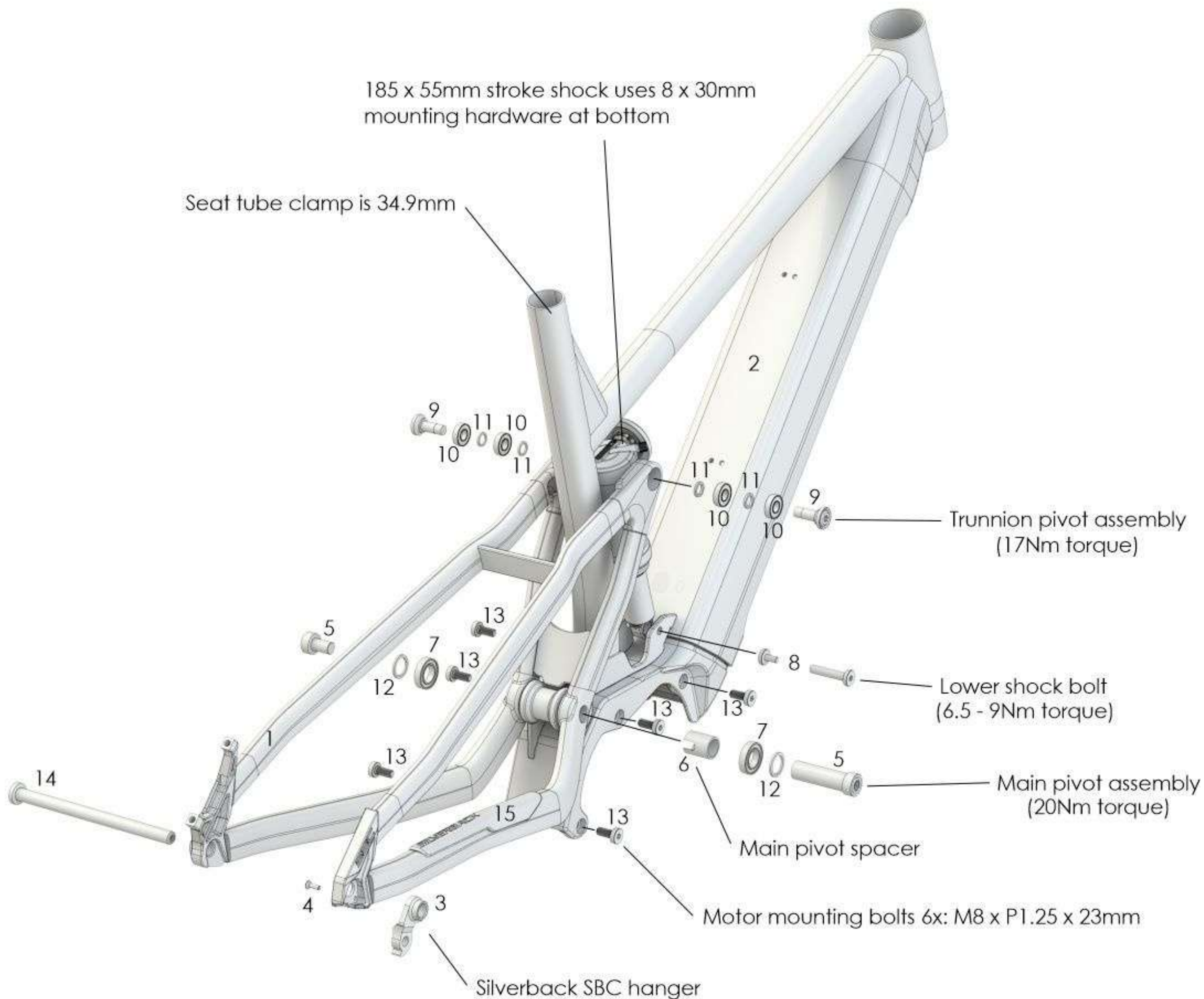

PLANET EARTH
PLEDGE



SILVERBACK
PROTECTING THE PLANET
& CARING FOR PEOPLE



DESIGN
ENGINEERING



BRAND FILMS.

[See for yourself](#)



RESOURCE CENTRE:

ACCESS TO THESE AND MORE THROUGH THE B2B ITS PORTAL:

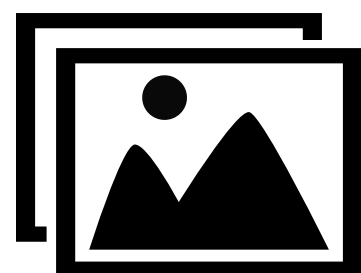

LIFESTYLE IMAGES

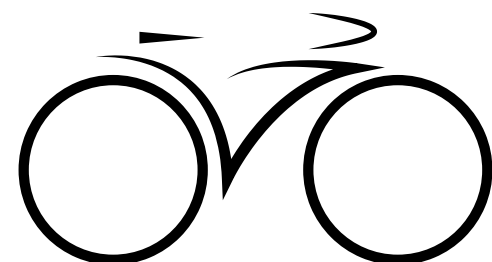

PRODUCT IMAGES

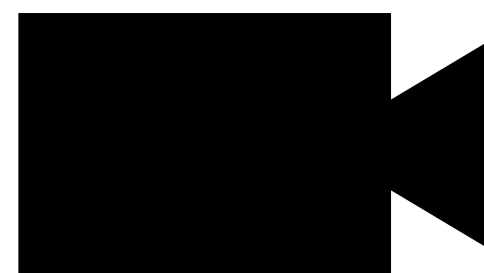

VIDEOS

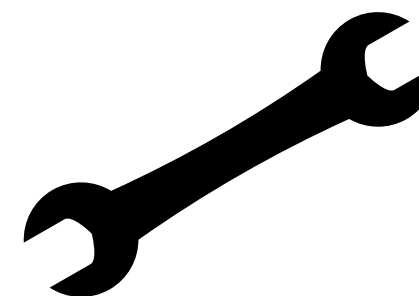

SPEC DOCUMENT

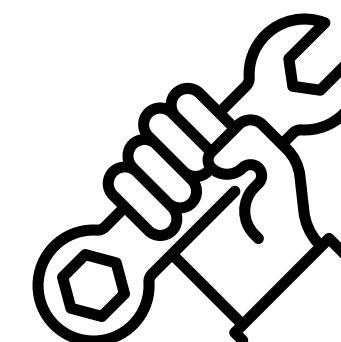

SPARE PARTS

SILVERBACK BIKES



#BORNTOBEEFAST

