

OUTLAND LIVING®

OWNER'S MANUAL

SUNSHINE COAST MODULAR OUTDOOR FURNITURE SYSTEM COMPONENT: CHAIR

OUTDOOR LIVING PERFECTED®

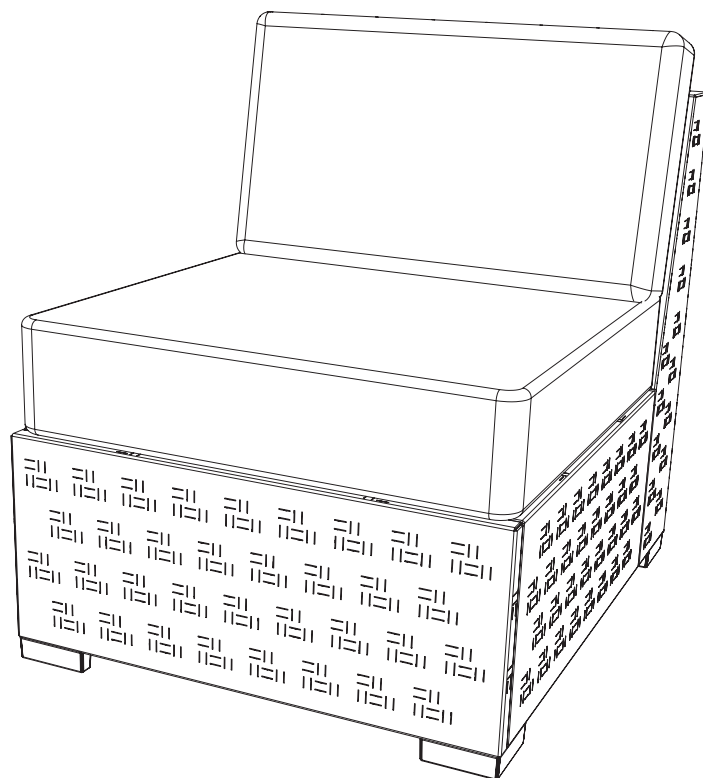

Model: OLSC-121





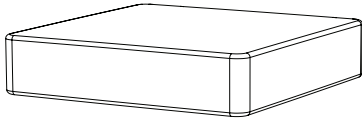
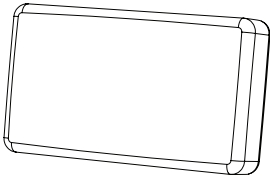
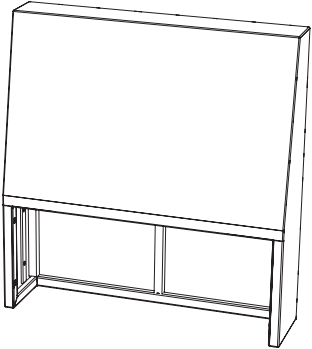
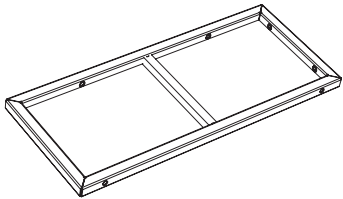
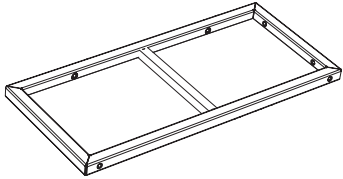
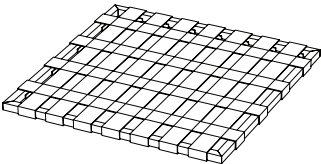

FMI BRANDS INC.

101 - 3570 194 Street, Surrey, BC Canada V3Z 1A5 • www.outlandliving.com
USA, Canada Toll Free: 1-888-514-1663 • Tel: (+1) 778-294-0988 • Email: info@outlandliving.com
Hours of Operation: 8:30AM - 4:00PM (Pacific Time) • Customer Service in English only

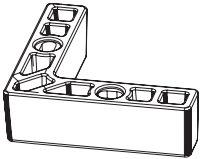
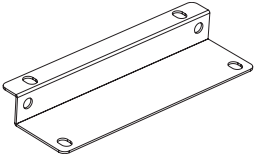
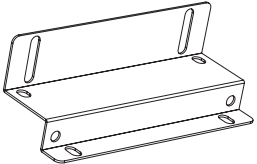
Supplied Parts & Hardware List:

PART #	DESCRIPTION	QUANTITY	PICTURE
1	Seat Cushion	1	
2	Back Cushion	1	
3	Chair Back	1	
4	Front Panel	1	
5	Side Panel	2	
6	Seat Panel	1	

PART #	DESCRIPTION	QUANTITY	PICTURE
7	Seat Support	4	
8	Foot	4	
9	Bracket-A	2	
10	Bracket-B	2	
11	3/4" Length Screws, 1/4 - 20 thread	28 +1	
12	1-1/2" Length Screws, 1/4 - 20 Thread	8 +1	
13	1/4 - 20 Flange Nut	4 +1	
14	5/32" Hex Key Tool	1	

Required Tools (Not Supplied):

Scissors

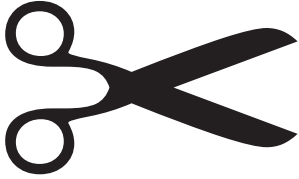

WARNING:

Improper assembly, adjustment, alteration, service or maintenance can cause injury or property damage. Read the Owner & Safety Manual instructions thoroughly before assembling or servicing this product.

INSTALLER: Leave this manual with the consumer.
CONSUMER: Retain this manual for future reference.

NOTES:

SECTION 1: ASSEMBLY

STEP 1

Unpack all parts on a level, non-marking surface.
Use scissors to open the vacuum-packed cushion bags.
Be careful not to cut the cushions.



SCISSORS



KNIFE



HANDLE WITH CARE

The Sunshine Coast modular component furniture system features high quality aluminum frames woven with 100% new all weather HDPE resin wicker and luxury cushions constructed with premium materials.

! ATTENTION:

The cushions will be wrinkled due to being vacuum-packed. DON'T WORRY! The wrinkles will naturally work themselves out. Vacuum-packing has reduced the packing box size and is a key component of the E-commerce shipping innovation.

STEP 2

On a level, non-marking surface, fasten the (2x) **Side Panels** to the **Chair Back** with (2x) **Bracket-A** and (8x) $\frac{3}{4}$ " **Length Screws**.
Use the provided $\frac{5}{32}$ " **Hex Key Tool**.

- Confirm the feet mounting holes are facing down.
- Confirm the Side Panels are mounted flush with the sides and aligned with the bottom of the Chair Back.
- After confirming A & B above, firmly tighten the (8x) bracket screws.

! **ATTENTION:**
Note the screw holes for mounting the feet on the (1x) **Front Panel** and (2x) **Side Panels**.

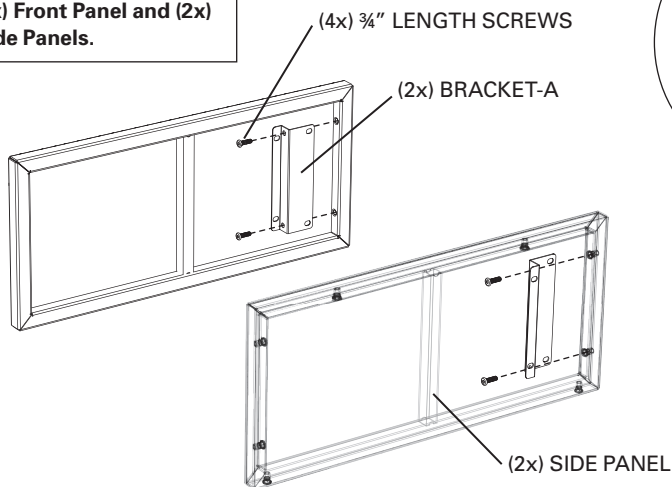

IMPORTANT: During assembly, ensure that these holes are all facing down!

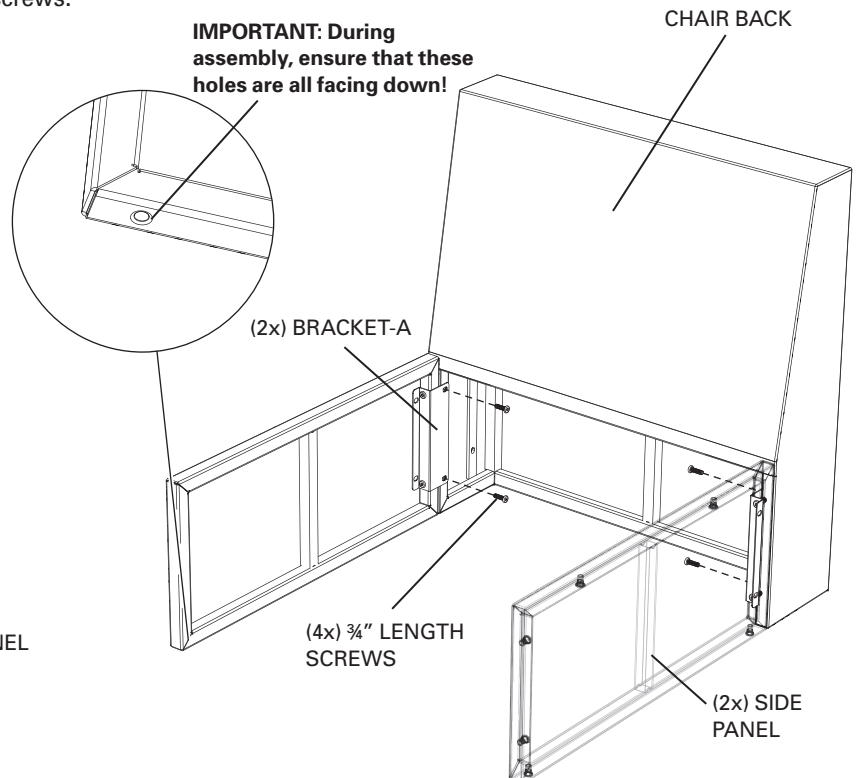

SECTION 1: ASSEMBLY (continued)

STEP 3

Fasten the (1x) Front Panel to the (2x) Side Panels with (2x) Bracket-B and (8x) 3/4" Length Screws.

- Confirm the feet mounting holes are facing down.
- Confirm the ends and bottom of the Front Panel are squarely aligned with the Side Panels.
- After confirming A & B above, firmly tighten the (8x) bracket screws.

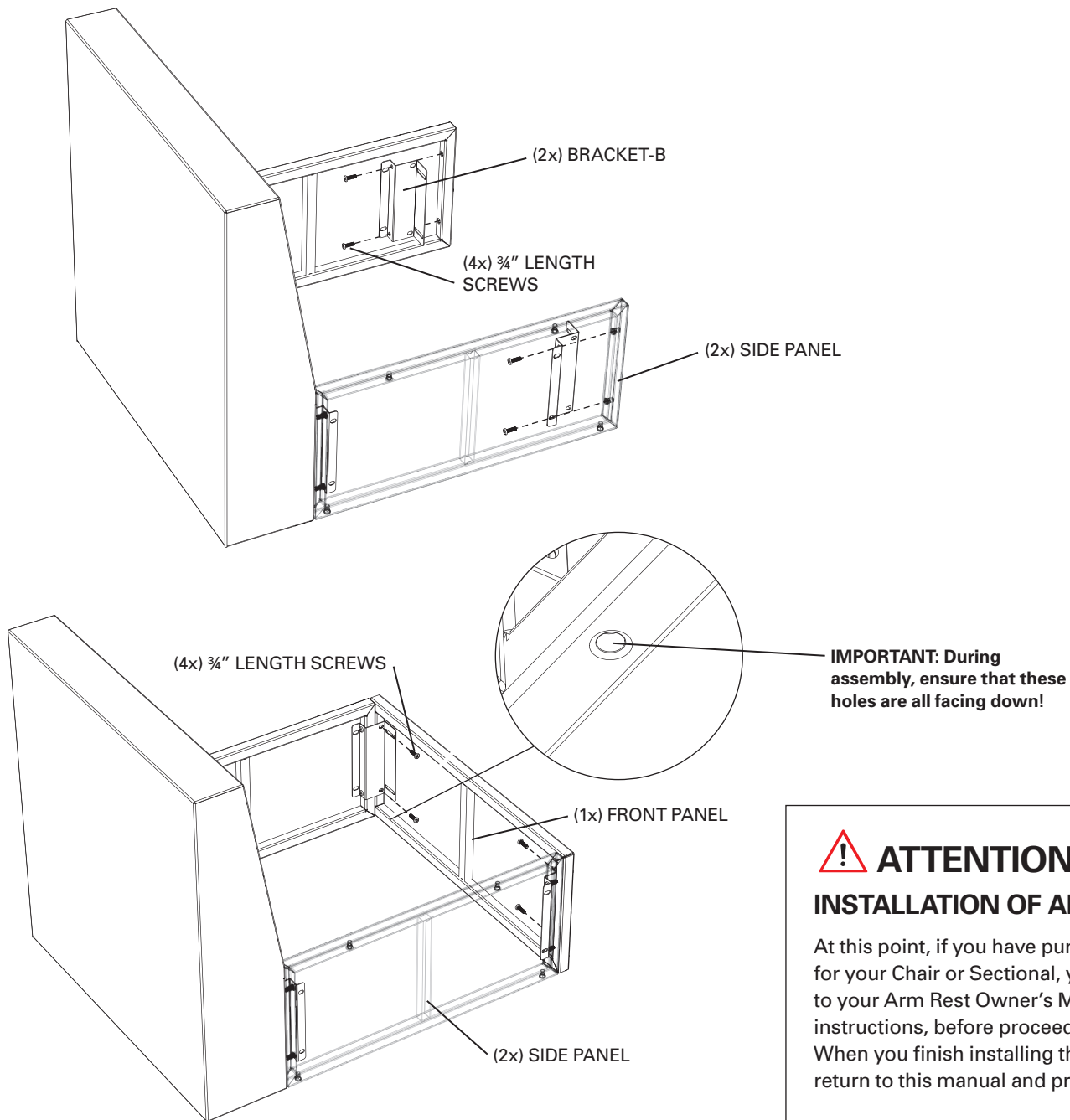

SECTION 1: ASSEMBLY (continued)

STEP 4

Flip the assembly over. Use two people to lift.
Take care not to scratch the wicker.

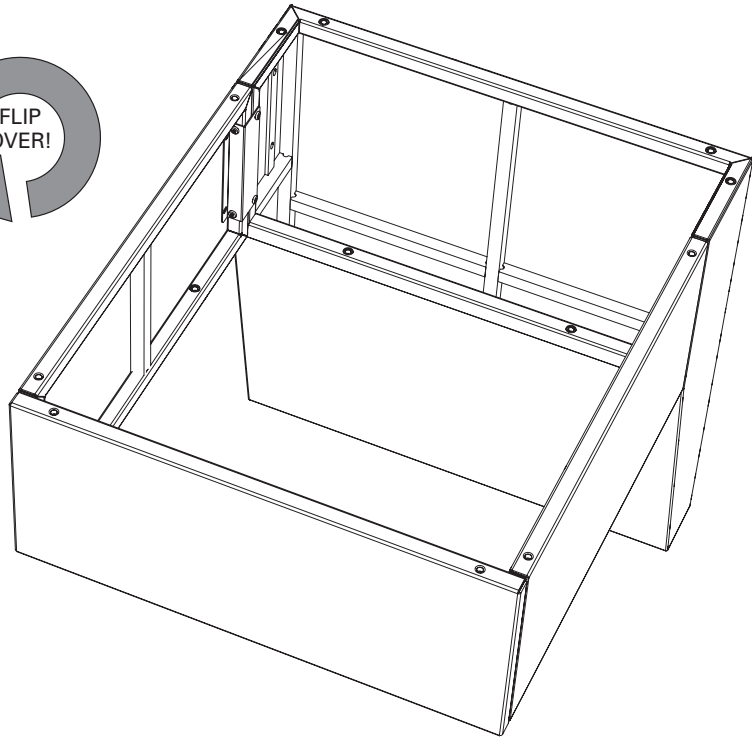

HEAVY OBJECT.
TWO PERSON LIFT REQUIRED.

STEP 5

Install the **(4x) Seat Supports** using **(8x) ¾" Length Screws**.
Ensure the ends of the wicker panels are squarely aligned.
Firmly tighten the seat support screws.

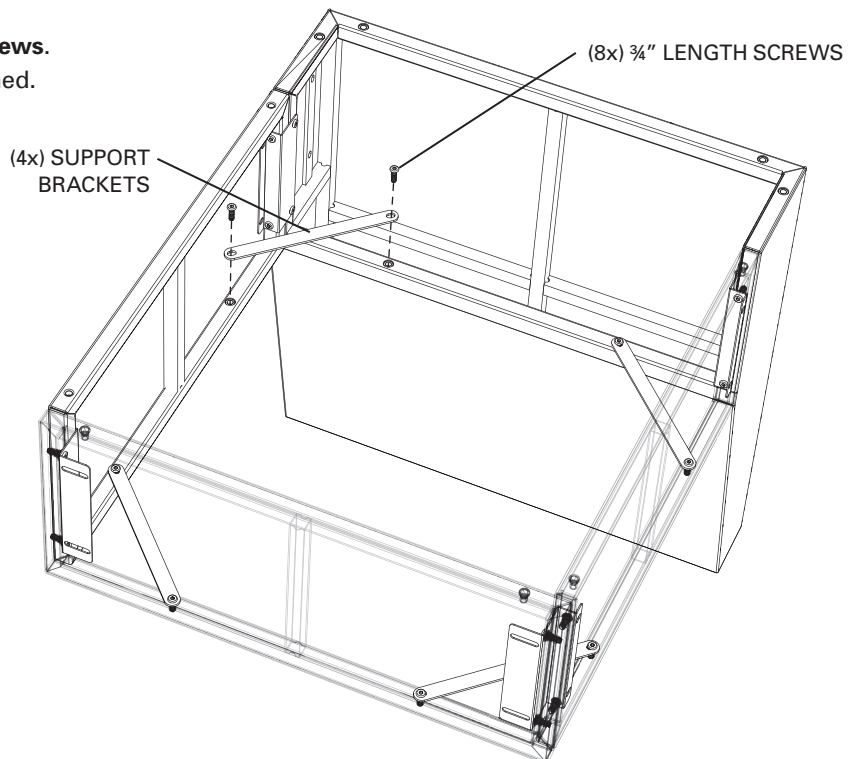

SECTION 1: ASSEMBLY (continued)

STEP 6

Install the (4x) Feet components using the (8x) 1-½" Length Screws. Ensure the ends of the wicker panels are squarely aligned. Firmly tighten the feet screws.

**Reference the installation instruction diagrams below, depending on which Chair configuration you are building. **

MIDDLE CHAIR FOR COUCH/LOVESEAT AND/OR SINGLE CHAIR WITHOUT ARMS

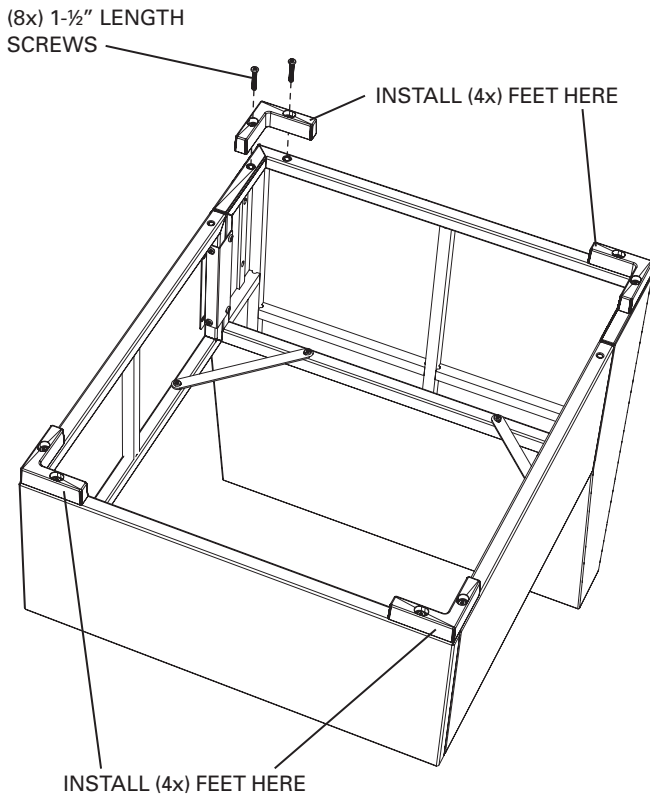

ARM CHAIR

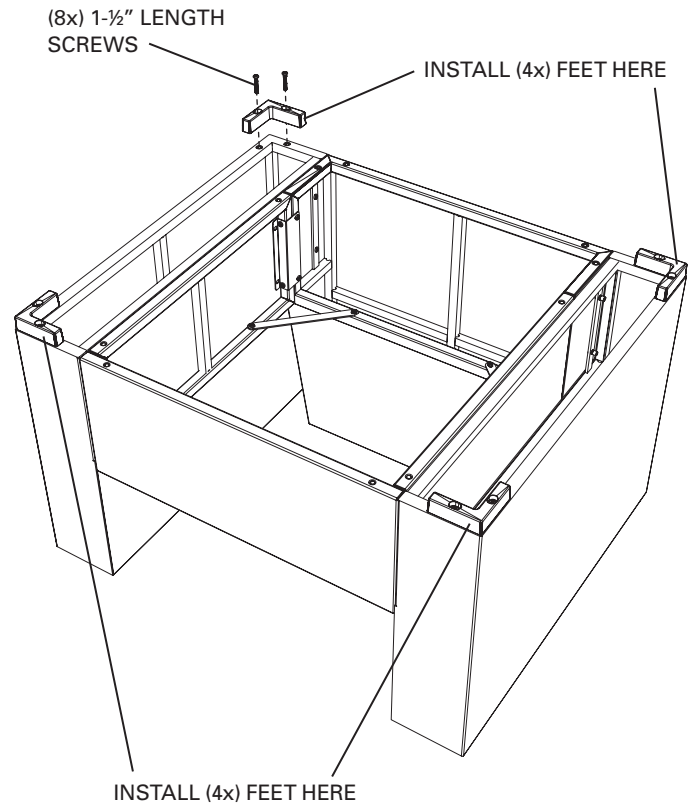

SECTION 1: ASSEMBLY (continued)

STEP 7

Confirm all wicker panels are squarely aligned.

Double-check the tightness of all screws.

Ensure all screws are firmly tightened.

Flip the assembly over so that the feet are contacting the ground.

Use two people to lift.

MIDDLE CHAIR FOR COUCH/LOVESEAT and/or SINGLE CHAIR WITHOUT ARMS

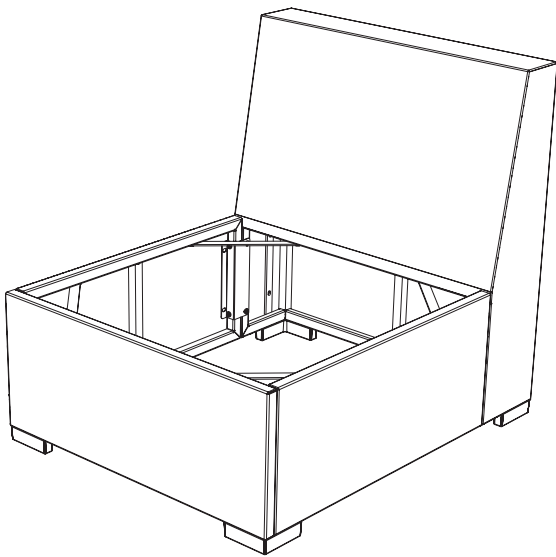

HEAVY OBJECT.
TWO PERSON LIFT REQUIRED.

ARM CHAIR

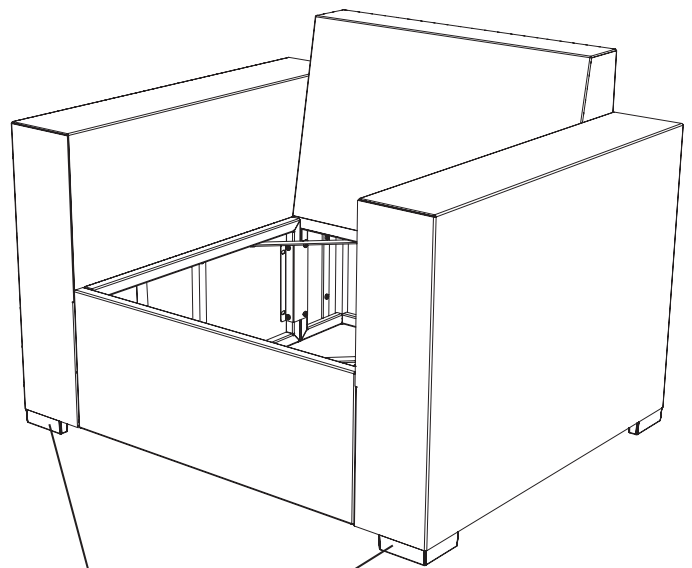

Note installation
location of feet!

SECTION 1: ASSEMBLY (continued)

STEP 8

Lay the **Seat Panel** onto the **Seat Supports**.

Note: For cushion support, the flat seat strap surface should be placed on the top side, so to be in contact with the cushion bottom.

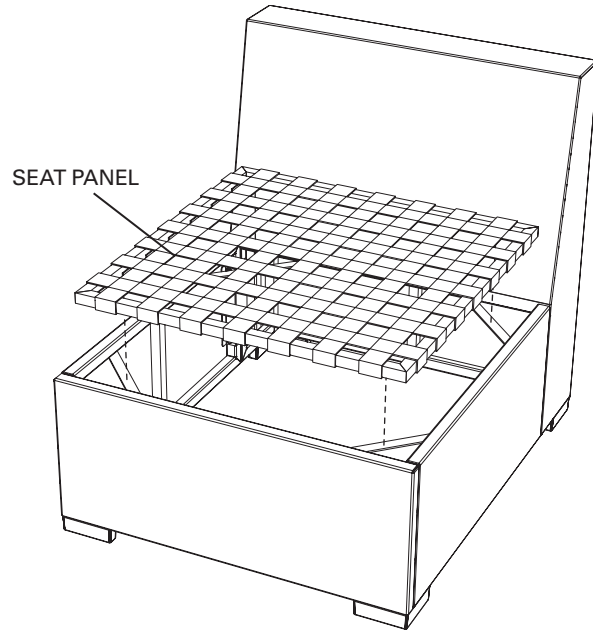

STEP 9

Place the **Seat Cushion** and **Back Cushion**.

1. The mesh seat cushion bottom should be facing down for water drainage;
2. The seat cushion zipper should face the back of the chair to remain hidden;
3. The back cushion zipper should face down to remain hidden.

Congratulations! Your chair is now assembled and ready for use. Don't worry if you have extra screws laying around, we included extra screws for you just in case.

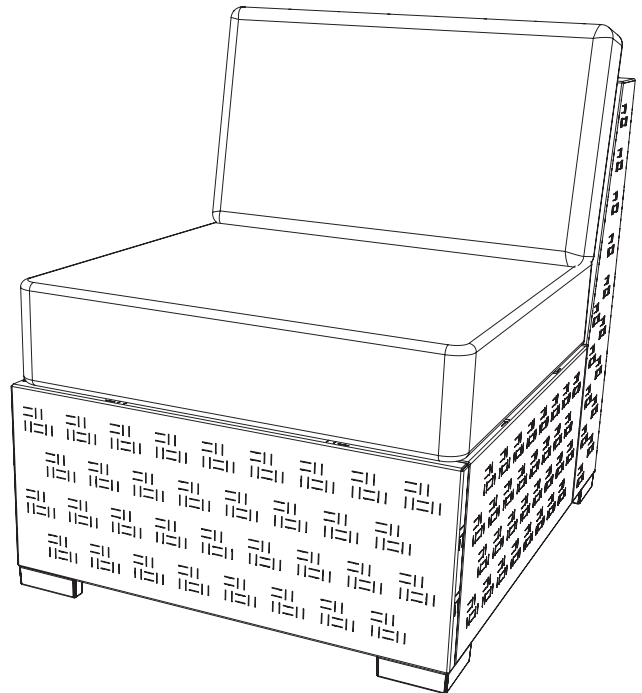

SECTION 2: SECTIONAL FASTENING

Each furniture panel has (4x) holes for assembling your modular furniture.

(4x) SECTIONAL MOUNTING HOLES

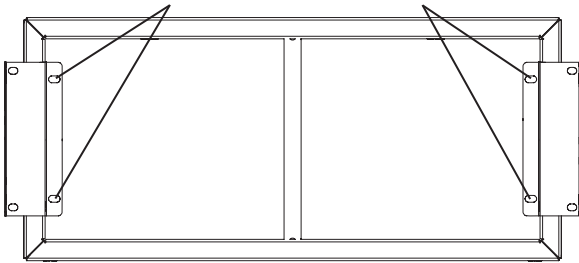

STEP 1A

To assemble one furniture component to another, use **(4x) 3/4" Long Screws** and **(4x) Flange Nuts**. Align your components. Push the screws through the holes in one panel, through the wicker, and through the holes in the panel on the opposite side.

TIP: USE THE HEX KEY TOOL AS A GUIDE FOR PUSHING THE SCREW THROUGH THE HOLES.

****See diagrams on next page.**

(4x) 3/4" LENGTH SCREW

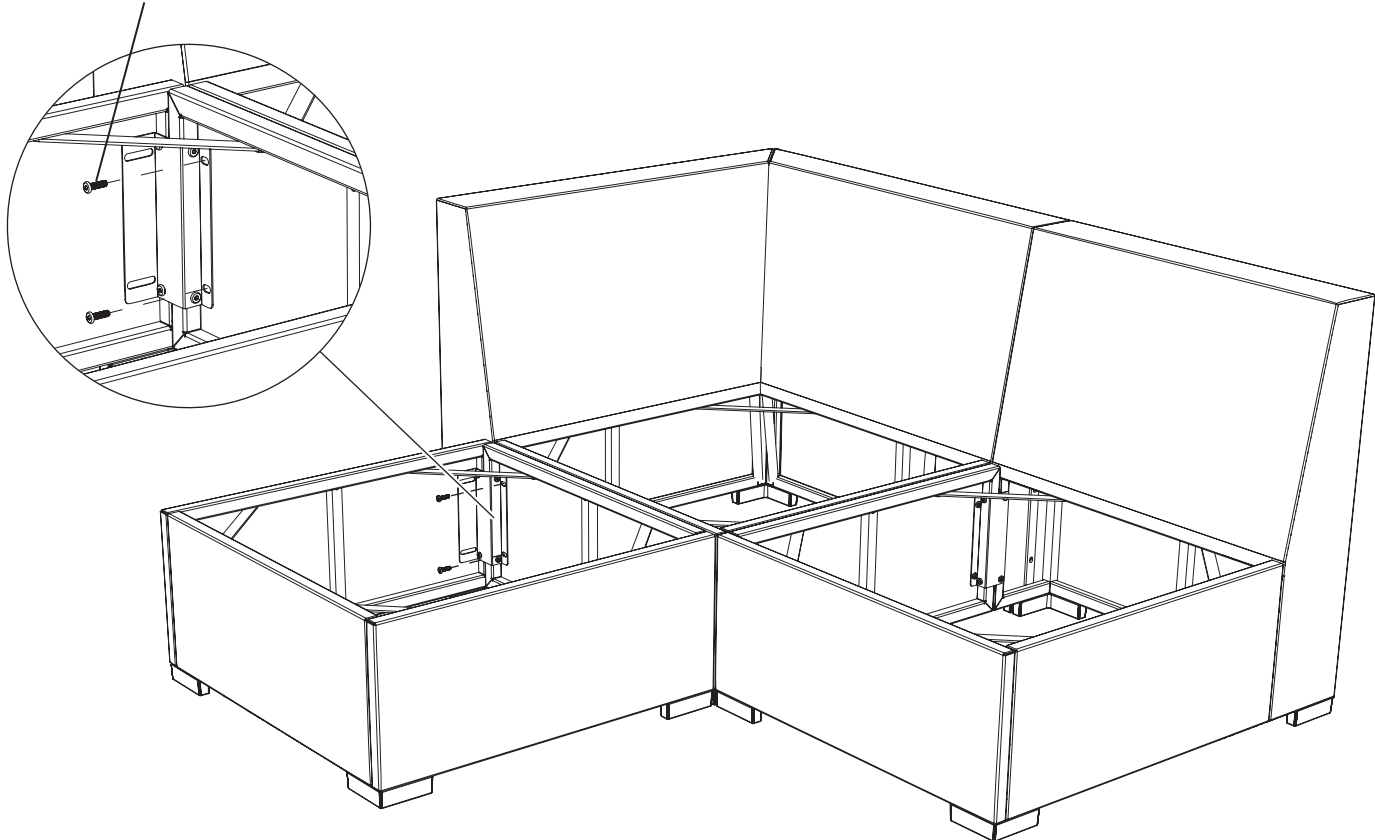

SECTION 2: SECTIONAL FASTENING (continued)

TIP: THE HEX KEY TOOL CAN BE USED AS A GUIDE TO PUSH THE SCREW THROUGH THE HOLES IN THE WICKER PANELS.

a) Wiggle the Hex Key Tool through the gaps in the wicker between both panels;

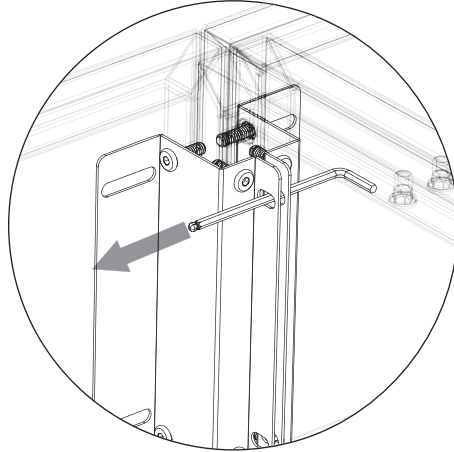

b) Align the tip of the screw with the end of the Hex Key Tool;

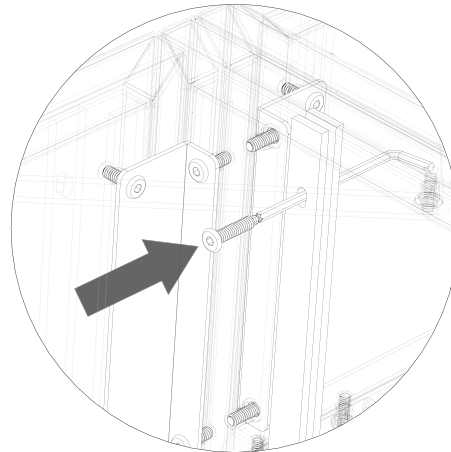

c) Keeping the two metal faces in contact, retract the Hex Key Tool and guide the screw through to the other side.

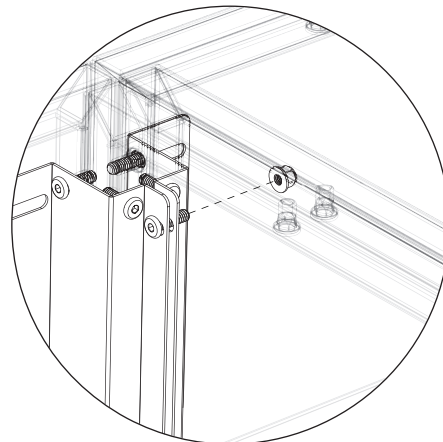
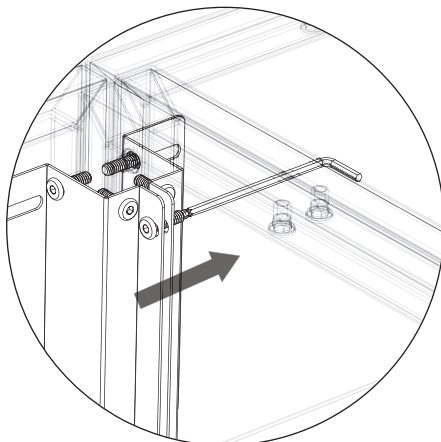

SECTION 2: SECTIONAL FASTENING (continued)

STEP 1B

Lock together using (4x) Flange Nuts.

Tighten with the Hex Key Tool.

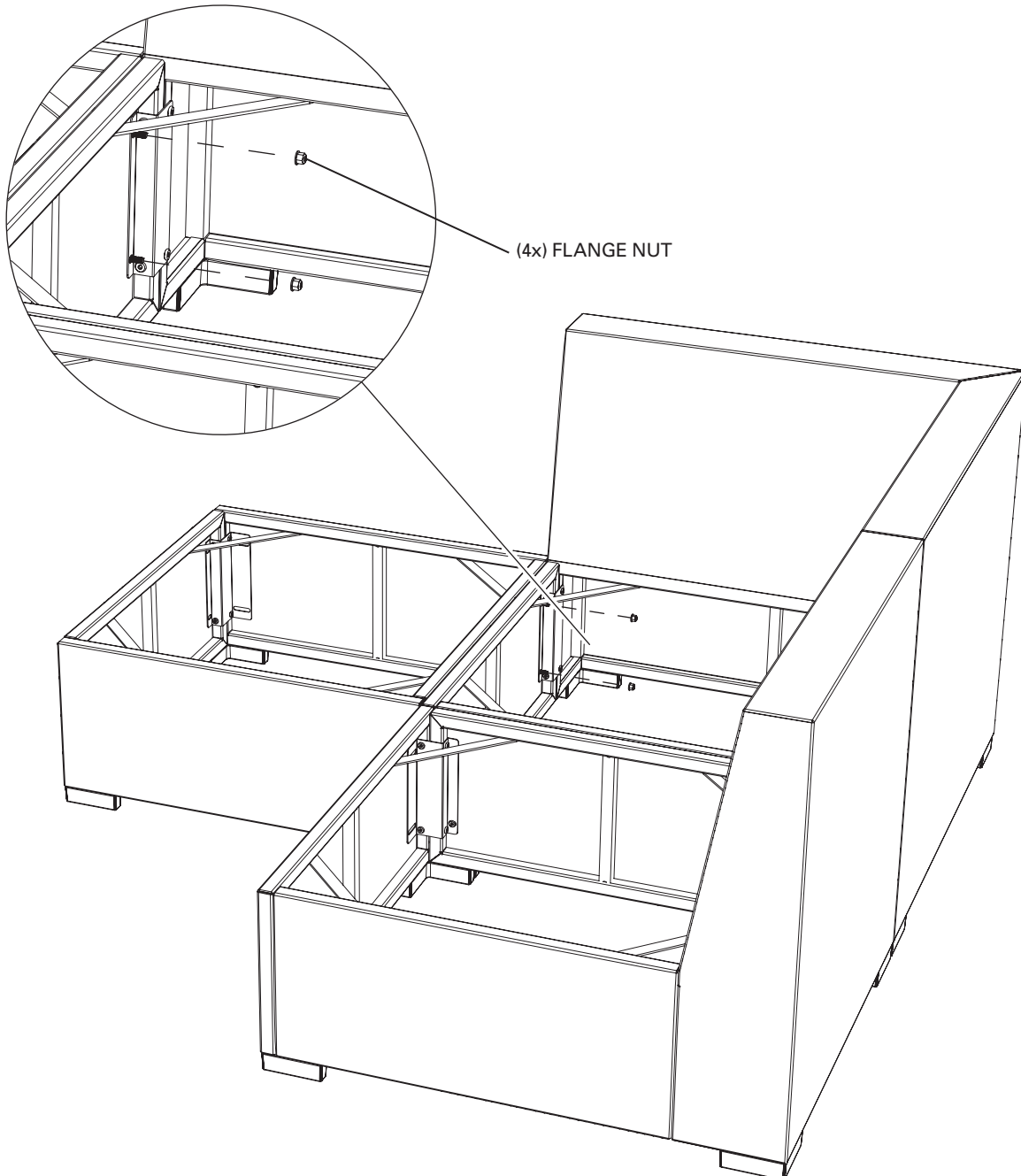

SECTION 2: SECTIONAL FASTENING (continued)

Arrange the different sections together in your preferred layout.

One such layout option is shown here. There is no limit to what you can build!

Additional modular components can be ordered from www.outlandliving.com.

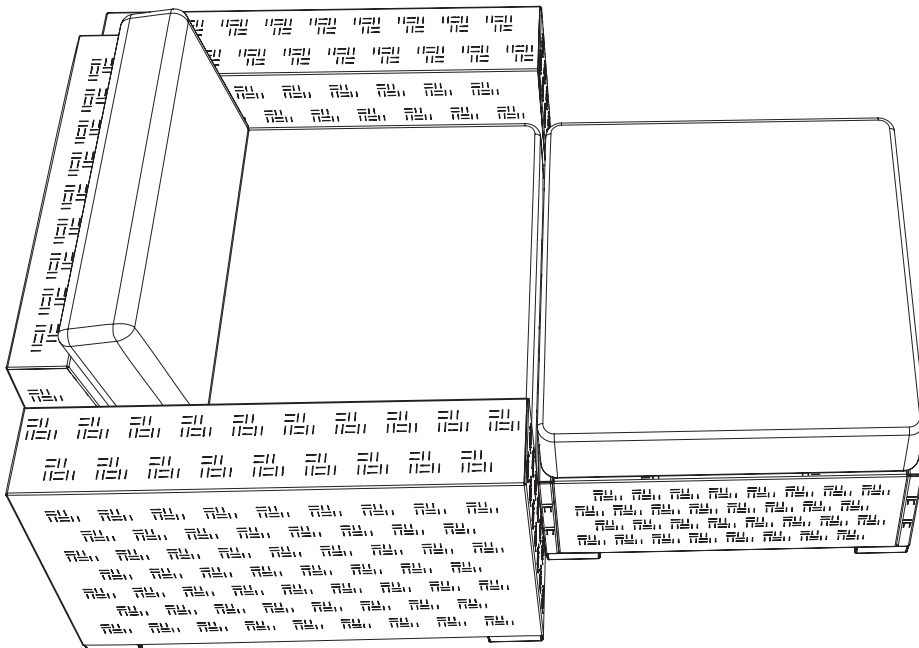
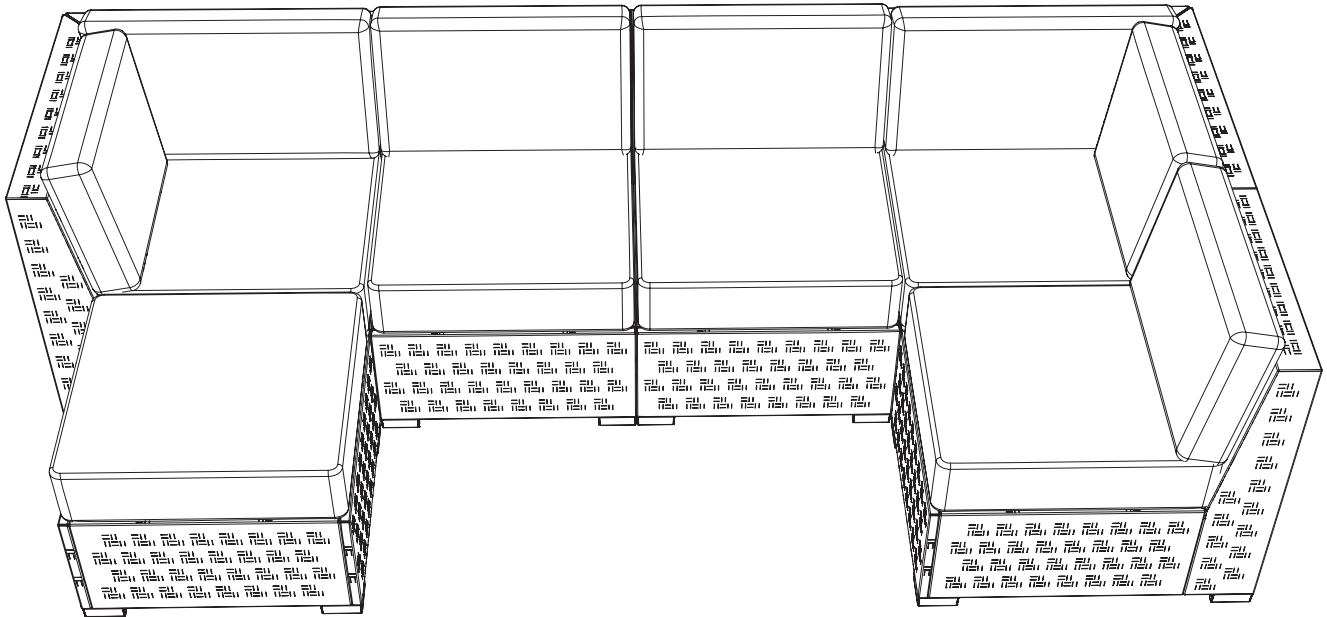

SECTION 3: MAINTENANCE

OUTLAND LIVING Outdoor Furniture is meant for outdoor use and requires periodic maintenance to keep it in good condition.

The all-weather resin wicker weave is made from 100% new high-density polyethylene. HDPE is commonly recyclable, BPA and Phthalate free and identified as the #2 plastic resin, the same material as milk jugs.

Should any part of the wicker furniture become soiled or dirty, wash down with soap and water. Use a soft brush and/or non-abrasive cloth. Use only water-based cleaners.

The furniture frame is made from durable powder coated aluminum. Rust should not be an issue.

The screw fasteners are made from 304 stainless steel. Routinely check fasteners to ensure they are firmly tightened.

Cover and/or store your furniture to protect it from the elements, between seasons, or when not in use.

Ensure the seat cushion mesh is facing down for water drainage.

ATTENTION:

The cushions will be wrinkled when freshly released from the vacuum pack bags. **DON'T WORRY!** The wrinkles will naturally disappear.

IMPORTANT!

Do NOT use petroleum based, alcohol based, flammable or corrosive cleaning products on or near the furniture. Doing so may destroy the wicker resin material! If in doubt, test a small inconspicuous section first.

ATTENTION:

The furniture cushion covers are removable and washable, but can be challenging to put back on. When replacing the covers, smooth the cushion interior batting to prevent lumps.

CUSHION CARE

- **Hand Washing (with or without the cushion cover removed):** Make a lukewarm water solution with 1/4 cup mild soap and one gallon of lukewarm water. Allow to absorb into the fabric. Lightly stir the stain with a sponge or a very soft bristle brush. Rinse thoroughly. Air dry. Heavier stains may need to be pre-soaked and machine washed.

- **Machine Washing:** Remove the covering with caution first. All zippers should be closed. Machine wash on the delicate cycle in cold water with a regular dose of mild laundry detergent. Allow the fabric to dry naturally.

WARNING NOTES:

- This product is not a toy.
- Children should always be supervised when using the furniture.
- Do not jump or climb on the furniture, as it may break or tip over, causing injury or death.
- Never allow children to climb inside the furniture interior compartments as they may become trapped, and/or injury or death could occur.
- **CAUTION:** Pinch points!
Watch out for pinching fingers when replacing the seat panel after lifting and/or accessing the inside compartment areas.
- **CAUTION:** Watch for sharp edges!
If the wicker somehow gets snagged and pulls a sharp corner, you can smooth it flat using a wooden spoon.

Our Quality Control team makes every effort to catch all the small imperfections, but sometimes something slips through. Here are some QUICK FIX Tips:

- If you happen to find a raised staple, please reset it by pushing it down.
- Exposed staples can usually be hidden by sliding the strands of wicker weave.

Periodically check under and inside the furniture compartments to clear insect or animal nests, especially after the furniture has been covered, stored, or unused for periods of time.

1 YEAR LIMITED WARRANTY **Customers in Canada and USA**

All components are warranted by the manufacturer for a period of 1 year after date of purchase by the original owner against defects in materials and workmanship under normal use.

This warranty does NOT cover normal wear and weathering, assembly and/or maintenance OR use in a commercial application. At FMI Brands Inc.'s sole discretion, products under warranty will be repaired and/or replaced at no charge to the customer.

Any returns sent back to FMI Brands Inc. must be sent via prepaid freight and in the original retail packaging.

Please register your OUTLAND Living product for proof of purchase and warranty at:

<https://outlandliving.com/register-products/>.

Registration in English only.

For more warranty information and details, please contact Customer Service at info@outlandliving.com.



If you experience ANY problems with your Outland Furniture Set, PLEASE DO NOT RETURN IT TO YOUR POINT OF PURCHASE!

Simply call us or send an email to info@outlandliving.com and we will answer all questions and/or concerns that you may have.

We take pride in our products at FMI Brands Inc. (Outland Living) and will strive to provide excellent customer support.

FMI BRANDS INC.

101 - 3570 194 Street, Surrey, BC Canada V3Z 1A5

USA, Canada Toll Free: 1-888-514-1663

Tel: (+1) 778-294-0988

Email: info@outlandliving.com

Hours of Operation: 8:30AM - 4:00PM (Pacific Time)

Customer Service in English only

**FOR REPLACEMENT PARTS AND ACCESSORIES PLEASE VISIT
WWW.OUTLANDLIVING.COM**

Replacement part orders can be sent by mail to the address on the cover of this booklet.

This Owner's Manual is available as a free download from www.outlandliving.com.