

FRONT VIEW

SIDE VIEW

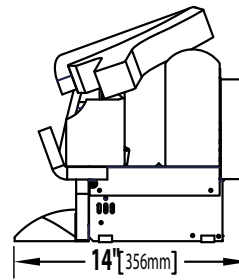

NEFI24H ILLUSTRATED

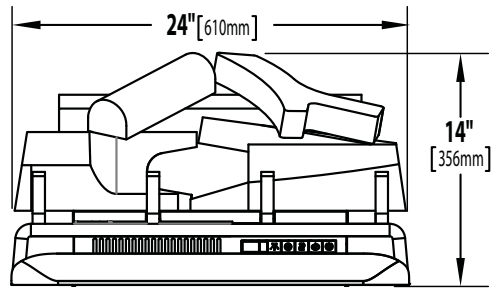
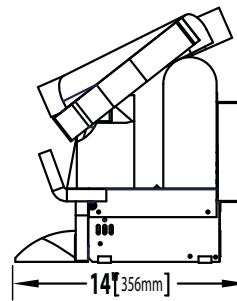
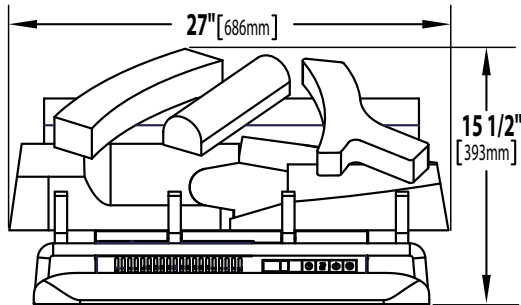

NEFI27H ILLUSTRATED

<b>Model Number</b>	NEFI24H	NEFI27H
<b>Description</b>	24" Electric Logset Insert	27" Electric Logset Insert
<b>Voltage</b>	120V AC	120V AC
<b>Watts</b>	Max 1500W	Max 1500W
<b>Amps</b>	15 AMP Grounded Circuit	15 AMP Grounded Circuit
<b>Appliance Width</b>	24" (610mm)	27" (686mm)
<b>Appliance Height</b>	14" (356mm)	15 1/2" (393mm)
<b>Appliance Depth</b>	14" (356mm)	14" (356mm)
<b>Net Weight</b>	20lbs (9.3kg)	23lbs (10.6kg)
<b>Gross Weight</b>	30lbs (14kg)	35lbs (16kg)

MINIMUM FIREPLACE CAVITY SIZE

LOG SET	HEIGHT	WIDTH	DEPTH
	A	B	C
NEFI24H	15" (381mm)	24" (610mm)	14" (356mm)
NEFI27H	16" (406mm)	27 1/2" (698mm)	14" (356mm)

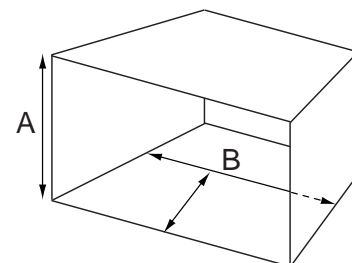

# 1. EMBER BED PLACEMENT

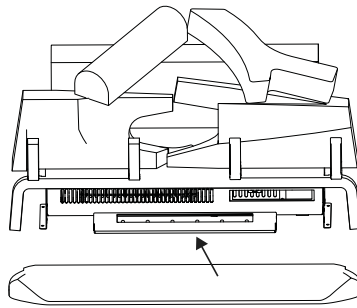

Place the ember bed over the LED tray, as shown.

## NEFI24H LOG PLACEMENT

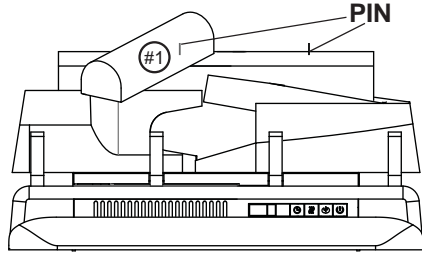

Place the log (#1) onto the pin. Ensure the log is secure onto the pin, as shown.

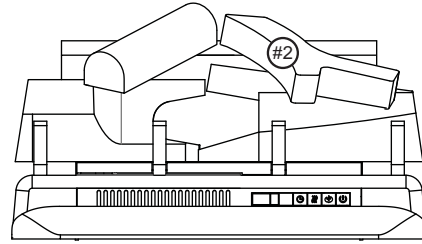

Place log (#2) onto the pin. Ensure the log is secure onto the pin, as shown.

## NEFI27H LOG PLACEMENT

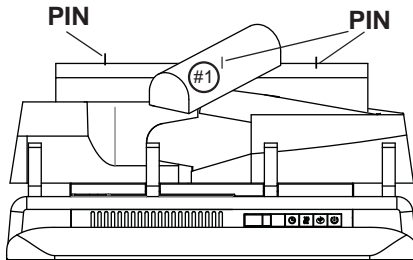

Place log (#1) onto the pin. Ensure the log is secure onto the pin, as shown.

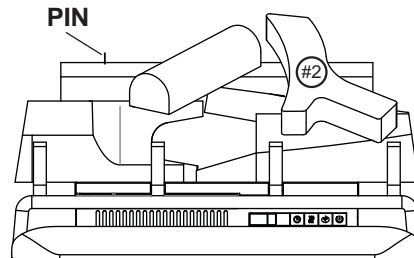

Place log (#2) onto the pin. Ensure the log is secure onto the pin, as shown.

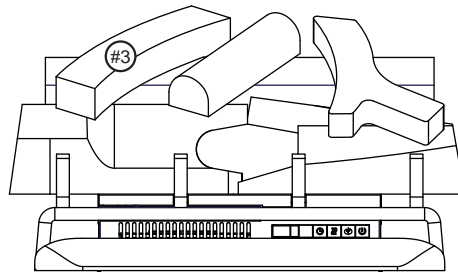

Place log (#3) onto the pin. Ensure the log is secure onto the pin, as shown.

# 2. CHARCOAL EMBER PLACEMENT

Place the charcoal ember around the front and sides of the ember bed, as indicated on the diagram below

