

# BODYRider

## DUAL TRAINER

For use under U.S. Patent numbers 6159132, D459773, D438264

BRD2835 / BRD2066  
DUAL TRAINER

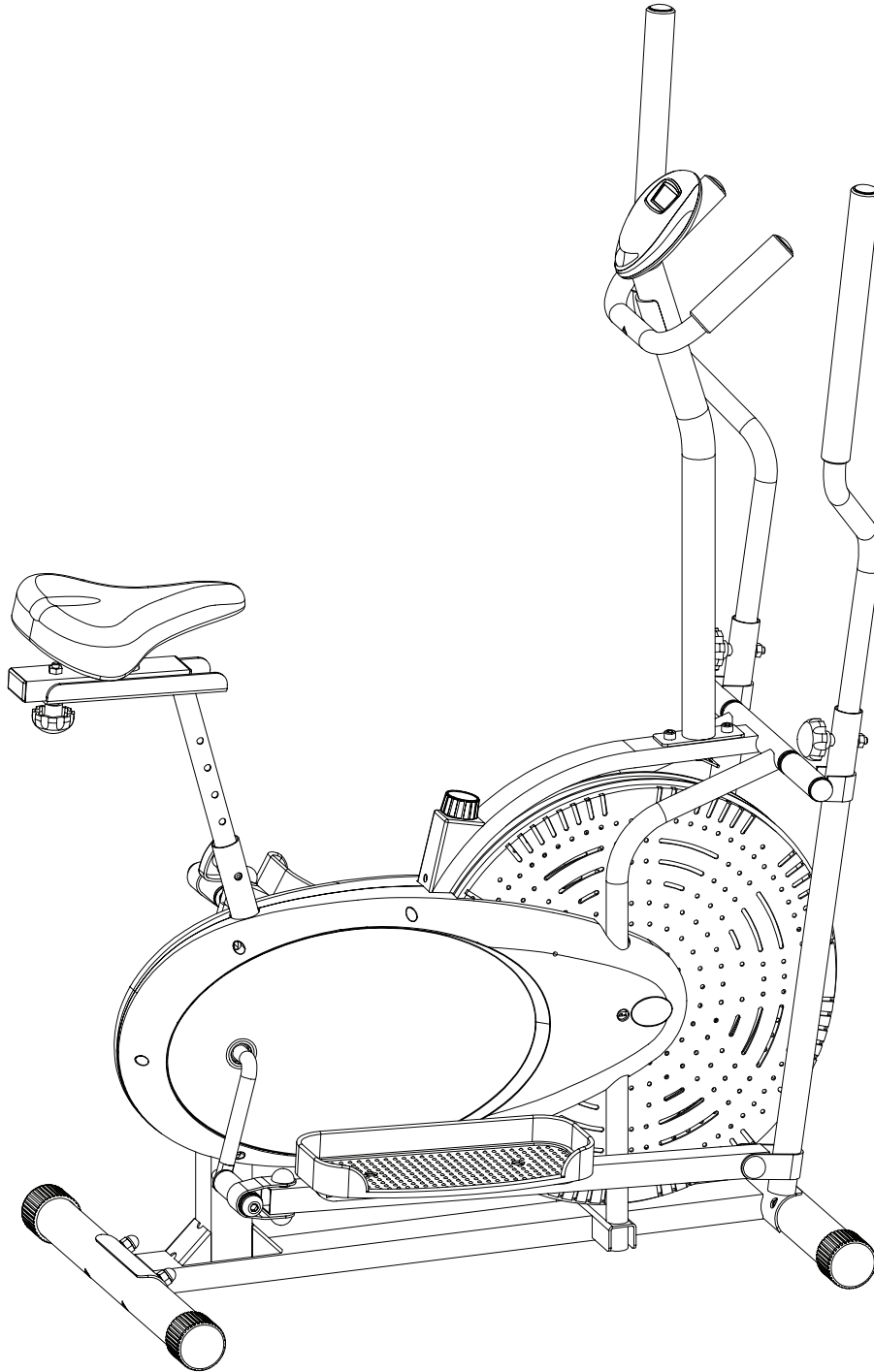

This product is intended for indoor, home use only and is not to be used in a commercial setting.

OWNER'S MANUAL

This page is left blank intentionally

**PLEASE KEEP THESE INSTRUCTIONS FOR FUTURE USE & REFERENCE.  
DO NOT DISCARD.**

**WARNING: SERIOUS INJURIES AND EVEN DEATH CAN OCCUR IF THE PROPER SAFETY PRECAUTIONS ARE NOT FOLLOWED.**

The diagram below highlights and reviews many of the important Safety and Warning labels also found on the unit. Please ensure any user of the unit familiarizes themselves with these Safety and Warning guidelines before use.

**⚠ WARNING !**

The use of this exercise equipment involves a **RISK OF PHYSICAL INJURY** as well as property damage, which can be minimized by observing the following guidelines:

1. **ALWAYS** wear comfortable clothing and shoes with good traction.
2. **ALWAYS** make sure all nuts and bolts are secured before use. **TIGHTEN PEDAL HINGE BOLTS EVERY 30 DAYS.**
3. **STOP EXERCISING** if you become dizzy, nauseous, have irregular heartbeats or breathing difficulties. Contact your physician immediately.
4. **ALWAYS** keep a large mat under the equipment to protect the floor or carpet.
5. **ALWAYS** use your equipment in a warm, dry, level, well-lit and ventilated indoor area.
6. **ALWAYS** keep body and clothing free and clear of moving parts.
7. **ALWAYS** keep your equipment clean and free of dust, moisture, debris and loose objects.
8. **NEVER** use the equipment if you are injured or have a physical condition that impairs your balance. **DO NOT** exercise under the influence of medication or alcohol.
9. **NEVER** allow small children or pets to approach the equipment. It is not a toy.
10. **NEVER** use the equipment if you exceed its weight limit of 250 lbs.
11. **NEVER** use the equipment if it does not function properly.

**⚠ WARNING !**

**DO NOT REMOVE THE SEAT FOR ANY REASON.**

Exercising on this unit without the seat installed can result in **SERIOUS INJURY**.

Ensure the seat is fully locked in place by tightening the knobs prior to use

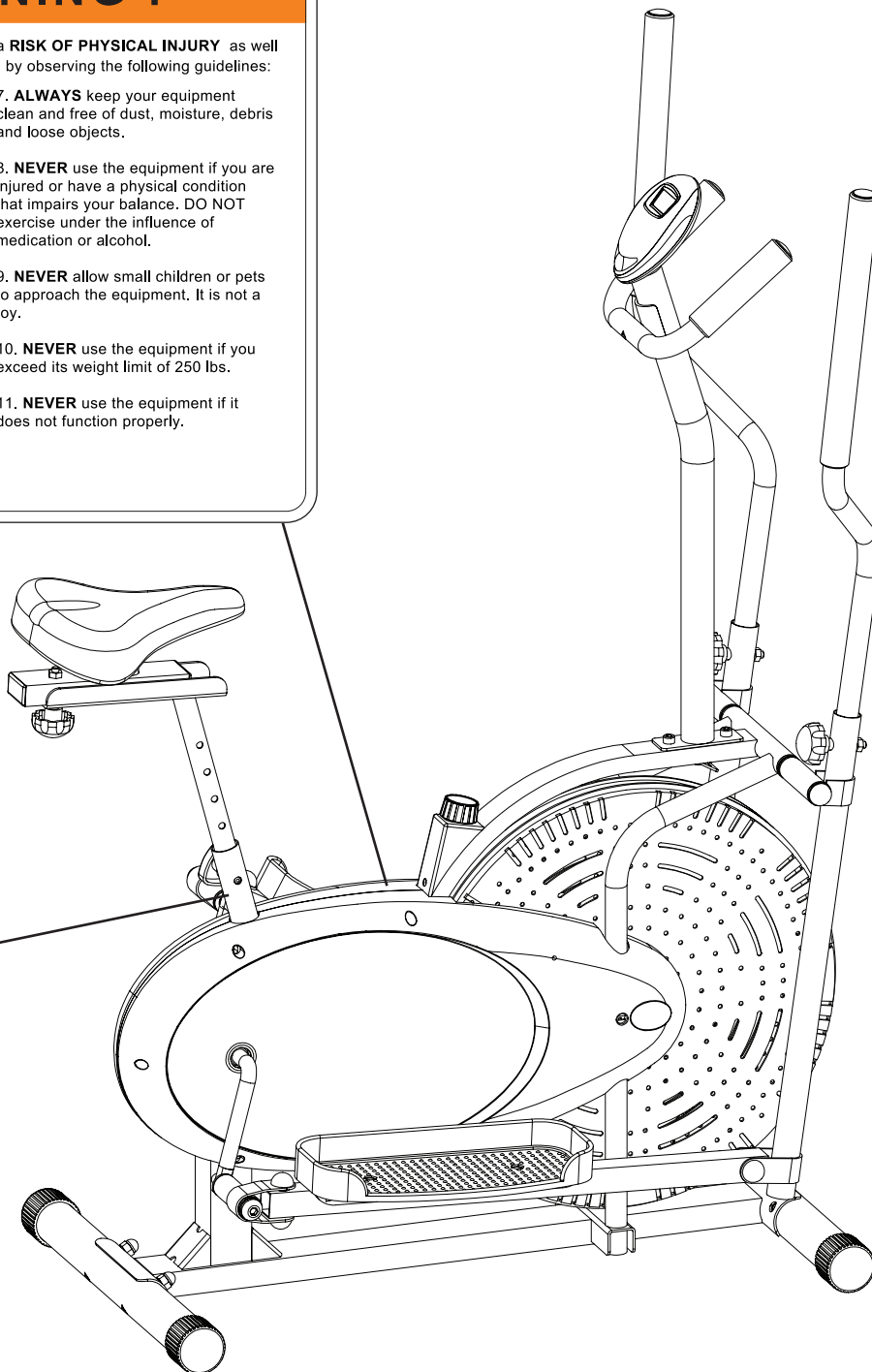

# General Information

---

## Safety

Before you undertake any exercise program, please be sure to consult with your doctor.

Frequent strenuous exercise should be approved by your doctor and proper use of your product is essential.

Excessive or incorrect training may result to health injuries.

Please read this manual carefully before commencing the assembly of your product or starting to exercise.

- Please keep all children away from this item when in use. Do not allow children to climb or play on this item when it is not in use.
- Supervise teenagers while they use this unit.
- For your own safety, always ensure that there is at least 3 feet of free space in all directions around your product while you are exercising.
- Regularly check to see that all nuts, bolts and fittings are securely tightened. Periodically check all moving parts for obvious signs of wear or damage.
- Any adjustment devices that could interfere with the user's movement on this unit should not be left projecting.
- Clean only with a damp cloth, do not use solvent cleaners. Lubricate the moving parts of your unit every 30 days with a silicone-based grease or product. If you are in any doubt, do not use your product; contact CUSTOMER SUPPORT.
- Before use, always ensure that your product is positioned on a solid, hard-flat surface.
- Do not place on carpet. If necessary, use a rubber mat underneath to reduce the possibility of slipping.
- Always wear appropriate clothing and footwear such as training shoes when exercising. Do not wear loose clothing that could become caught in moving parts during exercise.
- Do not use this unit if it is not functioning properly or if it is not fully assembled.
- Do not use this unit for commercial purposes. This unit is for home use only.
- Before use, you must read and understand all instructions & warnings stated in this Owner's Manual as well as posted on the equipment.
- It is the facility owner's responsibility to properly instruct users on the proper operation of the equipment and to warn them of the potential hazards.
- If at any time during exercise you feel faint, dizzy or experience pain, stop and consult your physician.

## Assembling Tools

- Ruler with both Metric and English measurements
- 2 x Adjustable Wrenches
- 1 x Philips ("Crosshead") Screw Driver

## Weight Limit

Your product is suitable for users weighing :  
250 pounds or less

## Storage and Use

Your product is intended for use in clean dry conditions. You should avoid storage in excessively cold or damp places as this may lead to corrosion and other related problems.

## Warranty

Body Flex Sports warrants your product for a period of 1 year for the frame and 90 days on all parts if the item is used for the intended purpose, properly maintained and not used commercially.

Any alterations or incorrect assembly of the product will void this warranty.

Proof of purchase must be presented for any warranty validation (no exceptions). This warranty applies to the original purchaser only and is not transferable.

This warranty does not cover abuse or defects caused during use, storage or assembly. During the warranty period, Body Flex Sports reserves the right to:

1. provide replacement parts to the purchaser in an effort to repair the item.
2. repair the product returned to our warehouse (at the purchaser's cost).
3. replace the product if neither of the two previously mentioned actions effect repair. This warranty does not cover normal wear and tear on upholstery.

## Questions

If you have any questions concerning the assembly of your item or if any parts are missing, please **DO NOT RETURN THE ITEM TO THE STORE OR CONTACT THE RETAILER.**

Our dedicated customer service staff can help you with any questions you may have regarding the assembly of this unit and can also mail you replacement parts.

## Customer Support

Customer Support is open 9:00 a.m. to 5:00 p.m. (Pacific Time) Monday through Friday.

Please contact us by any of the following means :

**Body Flex Sports, Inc.**  
21717 Ferrero Parkway, Walnut, CA 91789  
Telephone: 1 (888) 266 - 6789  
Fax: 1 (909) 598 - 6707  
Email: [info@bodyflexsports.com](mailto:info@bodyflexsports.com)

# Before Assembly

## ⚠ WARNING

1. Take a few minutes to familiarize yourself with the parts and hardware included with your product.
2. Assembly may require two people.
3. Check the frame for any damage and check any wiring (if present) for rips or tears. If you detect damage, rips, or tears, please contact our Customer Support Team before beginning any assembly.
4. Make sure all the hardware needed is included.
5. It is very important to follow the assembly instructions correctly and to make sure all parts are attached correctly and firmly tightened when the assembly process is complete.
6. Parts that are not tightened correctly will seem loose and can cause irritating noises and will cause damage to the equipment.

**PLEASE NOTE** : Many of the parts and hardwares listed on the parts list are already *pre-assembled* or installed on the unit.

## Nylon Lock Safety Nuts

1. It is only necessary to tighten the bolts and nuts to “finger tight” during the assembly process. This will make it easier to complete certain steps by allowing more tolerance for all the parts to fit properly.
2. Do not tighten all the nuts onto the bolts securely until after you have completed assembly of your product.
3. Use wrenches, pliers, or ratchet and sockets to tighten the bolts and nuts.
4. The Nylon Nut should thread onto the Hex Bolt until the end of the Hex Bolt has passed through the Nylon insert inside the Nut. Please follow this guideline everytime you see this *Nylon Nut icon* throughout the assembly steps.

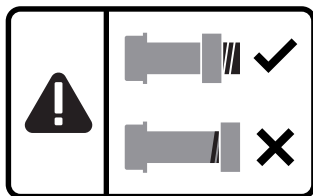

## Tools Required For Assembly

Tool	Description/Purpose
Ruler (with both Metric and English measurements) QTY: 1	Use to measure the length or size of hardware including bolts to ensure you are using the correct part.
Adjustable or flat wrenches QTY: 2	Use to securely install parts including nuts and bolts.

# Hardware and Tool List

The following hardware is used to assemble your unit. Please take a moment to familiarize yourself with these items.

**PLEASE NOTE:** Most of these parts are already *pre-assembled* on your unit. Do not be alarmed if you see parts on this page that are not included in your hardware packet.

## Bolt

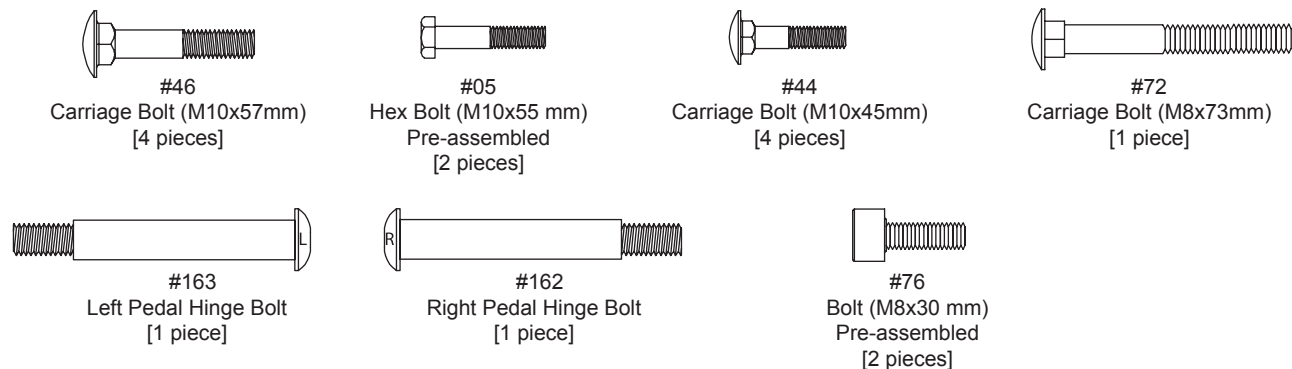

## Washer

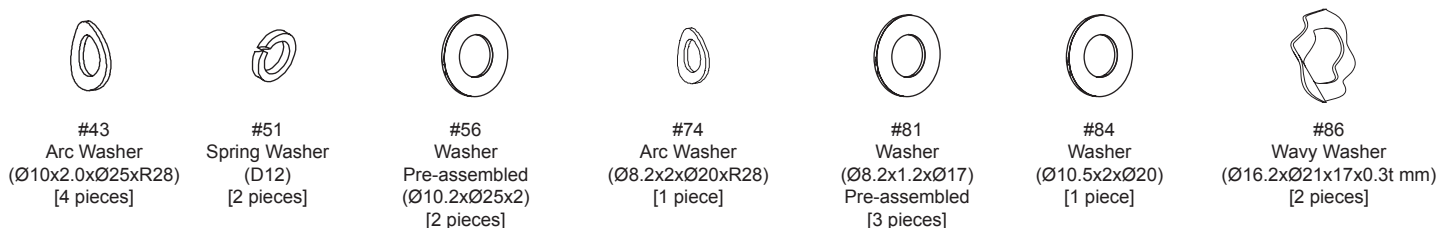

## Nut

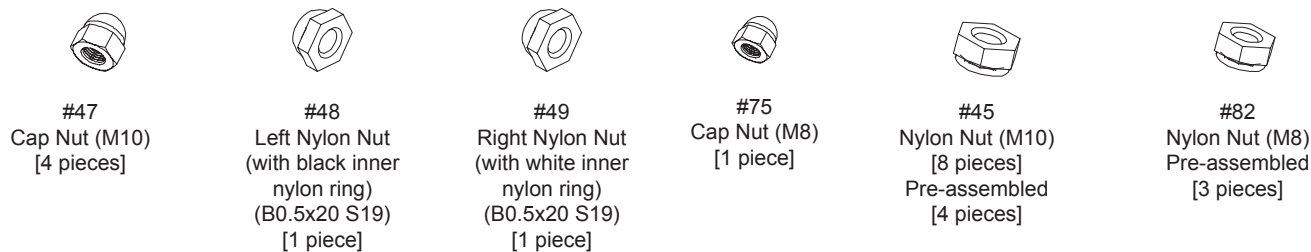

## Others

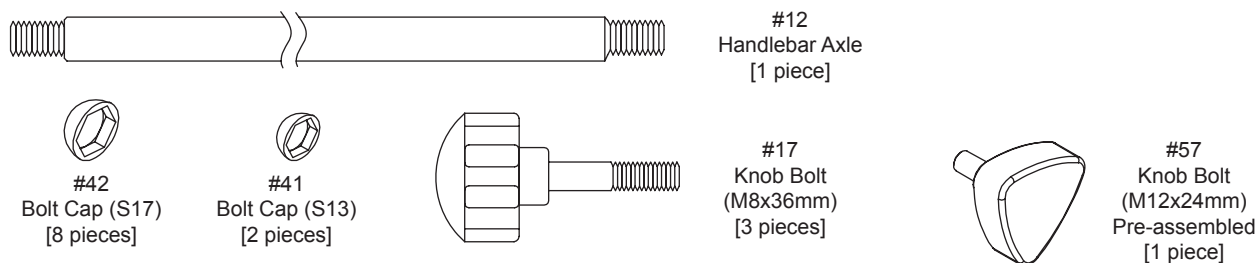

## Tools (Included)

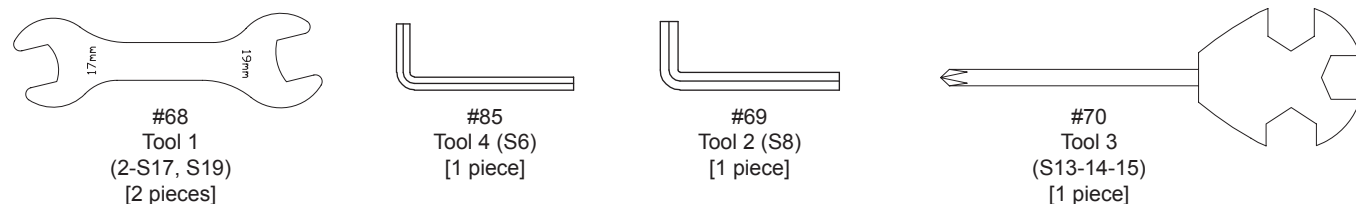

# Assembly STEP 1

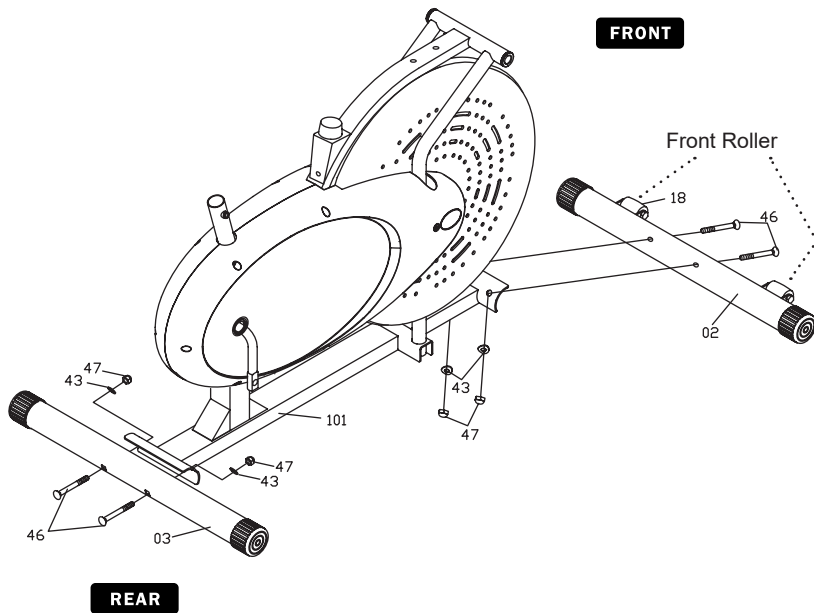

## Hardware Required

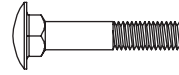

#46  
Carriage Bolt (M10x57mm)  
[4 pieces]



#43  
Arc Washer  
(Ø10x2.0xØ25xR28)  
[4 pieces]



#47  
Cap Nut (M10)  
[4 pieces]

## REAR STABILIZER ASSEMBLY

With the help of an assistant, attach the Rear Stabilizer (#03) to the rear of the Main Frame (#101). Insert two Carriage Bolts (#46) through the Rear Stabilizer (#03) to the rear of the Main Frame (#101). Secure them together using two Arc Washers (#43) and two Cap Nuts (#47).

## FRONT STABILIZER ASSEMBLY

Now, attach the Front Stabilizer (#02) to the front of the Main Frame (#101). Insert two Carriage Bolts (#46) through the Front Stabilizer (#02) to the front of the Main Frame (#101). Secure them together using two Arc Washers (#43) and two Cap Nuts (#47).

### Note:

Please note that the Front Stabilizer (#02) has Front Rollers (#18) that spin for ease of relocating the unit.

# Assembly STEP 2

Remove the Nylon Nuts (#45) and Washers (#56) that are pre-assembled on the Handlebar Axle (#12) and set them aside as they will be used later in this step.

Insert the Handlebar Axle (#12) through the main frame. Make sure the Handlebar Axle (#12) is centered. If you encounter too much friction, try using WD40 or Vaseline as a lubricant.

Please refer to the “Note:” and image below and properly attach Left Coupler Bar (#04L) and Right Coupler Bar (#04R) to the main frame via the Handlebar Axle (#12). Again, use WD40 or Vaseline to reduce friction if needed.

Once the Left Coupler Bar (#04L) and Right Coupler Bar (#04R) are correctly situated, fasten the end of the Handlebar Axle (#12) with a Washer (#56) and a Nylon Nut (#45) on each side. Then cap each end with a Bolt Cap (#42).

### Hardware Required

#56 Washer (Ø10.2xØ25x2) [2 pieces]

#45 Nylon Nut (M10) [2 pieces]

#12 Handlebar Axle [1 piece]

#42 Bolt Cap (S17) [2 pieces]

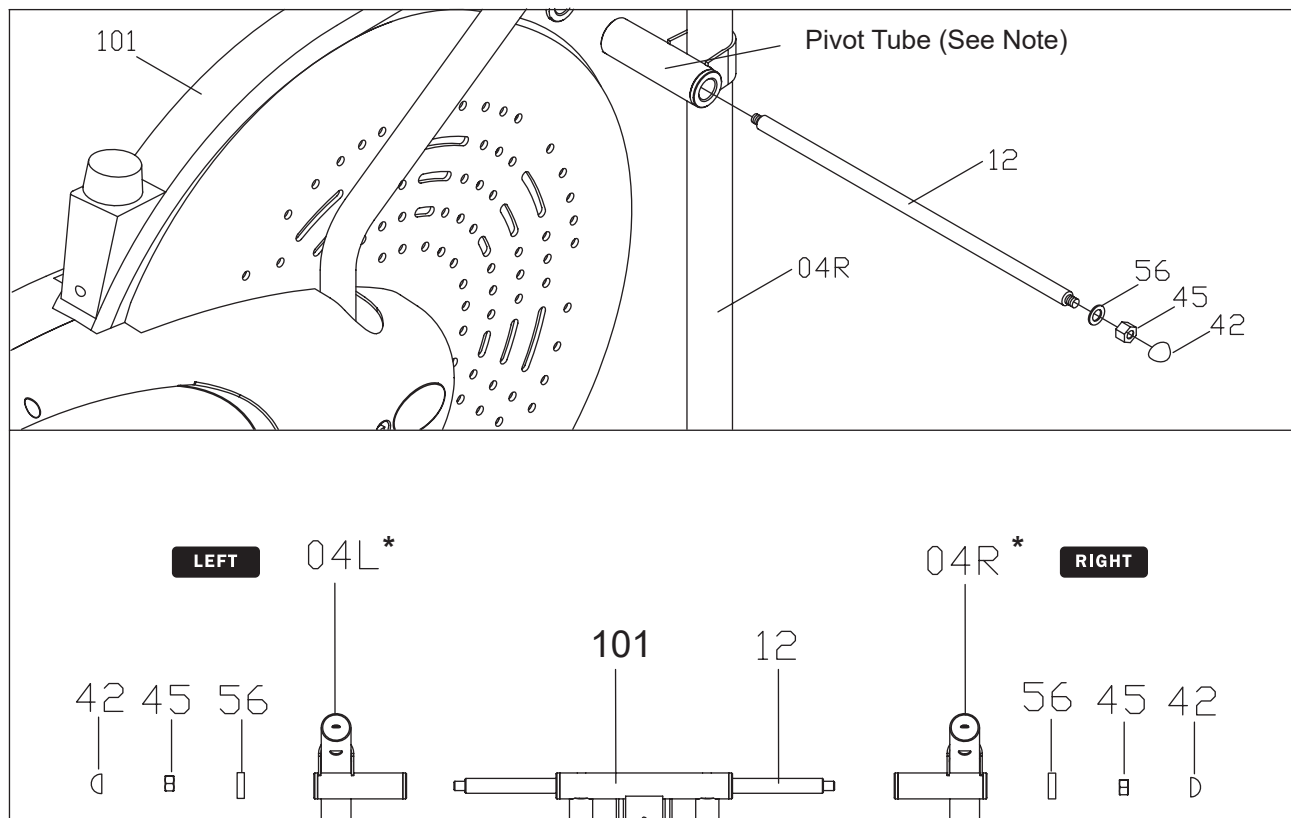

\* To avoid incorrect assembly, please use illustration above as reference and ensure #04L is installed on the LEFT side and #04R is installed on the RIGHT side.



# Assembly STEP 3

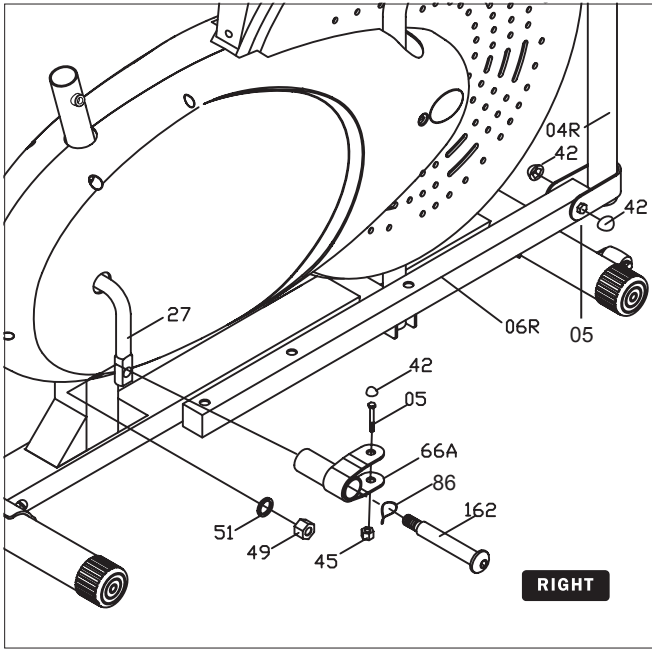

Remove Hex Bolts (#05) and Nylon Nuts (#45) that are pre-assembled on the Pedal Connection Joint (#66A) and set them aside as they will be used in a later process.

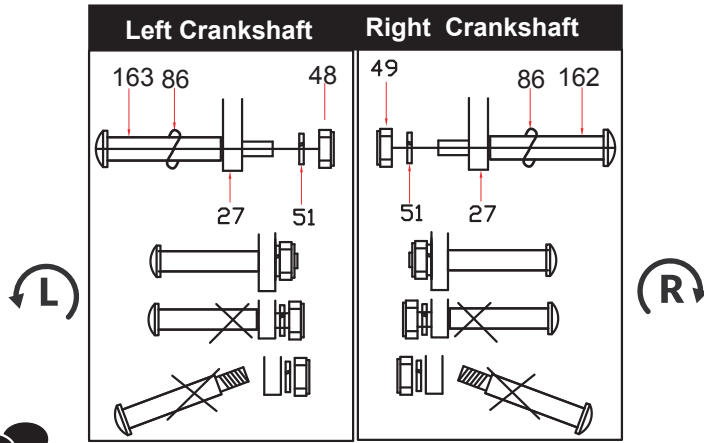

### IMPORTANT NOTES FOR THIS ASSEMBLY STEP:

1. Ensure you insert Right/Left Pedal Hinge Bolt (#163/162) straightly and aligned (not crooked) to properly engage through Right/Left Pedal Tube (#06R/06L) and Right/Left Crank (#27R/27L). If these parts do not engage properly or do not fit snugly, then damage will likely occur.
2. Pay close attention to the direction you are turning Right/Left Pedal Hinge Bolt (#162/163) as detailed in directions above. (Right Pedal Hinge Bolt (#162) = turn CLOCKWISE  
Left Pedal Hinge Bolt (#163) = turn COUNTER-CLOCKWISE).
3. Make sure to use a tool (not just hands) to fully tighten Right/Left Pedal Hinge Bolt (#162/163) to pass through Right/Left Nylon Nut (#49/48).

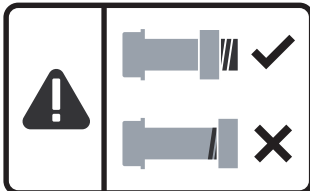

## Hardware Required

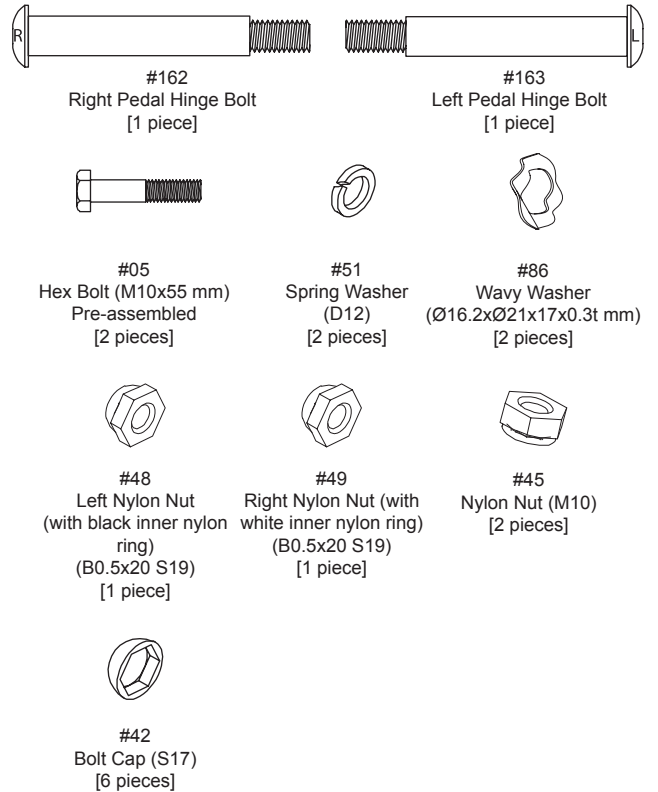

Attach the Pedal Connection Joint (#66A) to the Right Pedal Tube (#06R). Insert a Hex Bolt (#05) through the upper bracket of the Pedal Connection Joint (#66A), followed by Right Pedal Tube (#06R) then the lower bracket of the Pedal Connection Joint (#66A). Secure them with a Nylon Nut (#45).

Attach three Bolt Caps (#42) on three Hex Bolts (#05) as illustrated in the drawing. Align and attach the Pedal Connection Joint (#66A) on the Right Pedal Tube (#06R) to the right Crankshaft (#27).

Insert the Right Pedal Hinge Bolt (#162) through one Wavy Washer (#86), followed by Pedal Connection Joint (#66A) and Crankshaft (#27). Install the Right Pedal Hinge Bolt (#162) tightly into the Crankshaft (#27) by turning CLOCKWISE, then secure with a Spring Washer (#51) and a Right Nylon Nut [with white inner nylon ring] (#49).

Repeat the above process on the left side of the machine but install the Left Pedal Hinge Bolt (#163) by turning COUNTER-CLOCKWISE.

# Assembly STEP 4

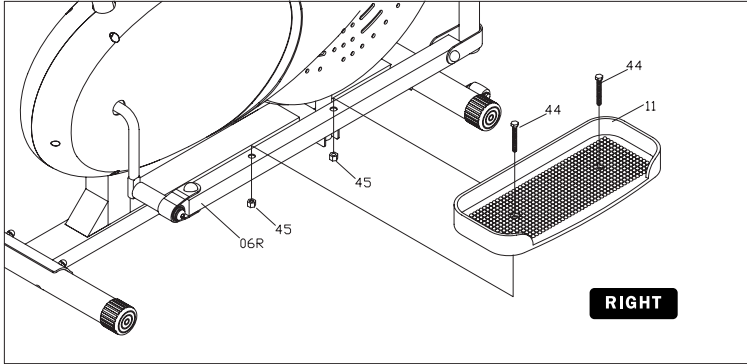

## Hardware Required

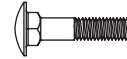

#44  
Carriage Bolt (M10x45mm)  
[4 pieces]



#45  
Nylon Nut (M10)  
[4 pieces]

Attach one Pedal (**#11**) as oriented below in diagram to the Right Pedal Tube (**#06R**) and secure them together using two Hex Bolts (**#44**) and two Nylon Nuts (**#45**).

Repeat this process on the other side using the other Pedal (**#11**) onto the Left Pedal Tube (**#06L**).

# Assembly STEP 5

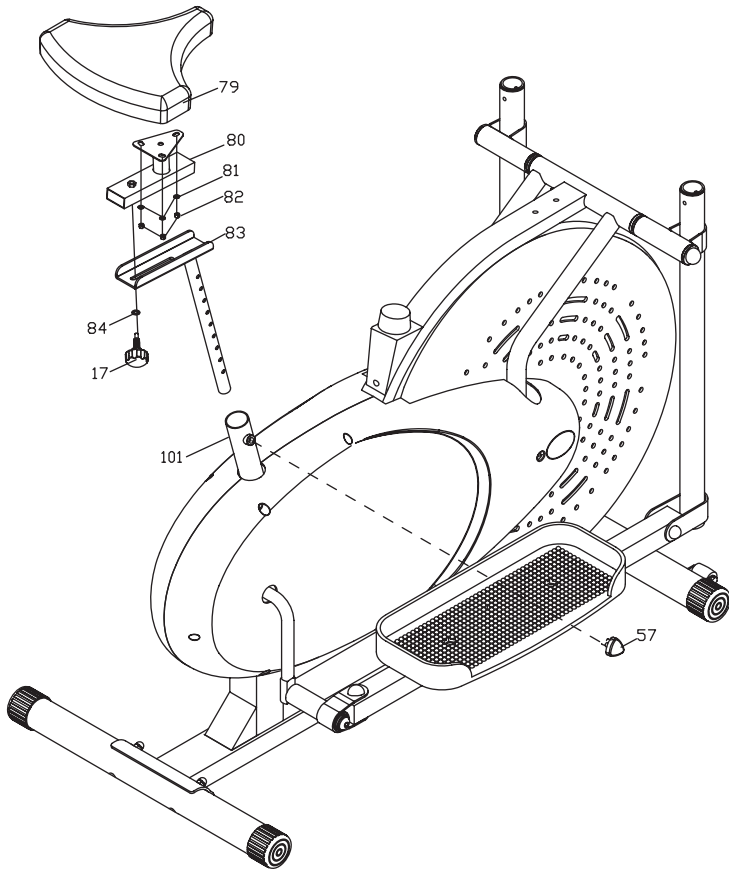

You may adjust the Seat Post (#83) to the height most comfortable for you after complete assembly. Please always check to ensure a hole has been fully engaged when you secure and tighten the Knob Bolt (#57).

## Hardware Required



#81  
Washer  
(Ø8.2x1.2xØ17)  
[3 pieces]



#84  
Washer  
(Ø10.5x2xØ20)  
[1 piece]



#82  
Nylon Nut (M8)  
Pre-assembled  
[3 pieces]

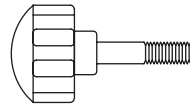

#17  
Knob Bolt  
(M8x36mm)  
[1 pieces]

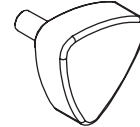

#57  
Knob Bolt  
(M12x24mm)  
Pre-assembled  
[1 piece]

Remove Washers (#81) and Nylon Nuts (#82) that are pre-assembled on the back of the Seat (#79) and set them aside as they will be used later in this step.

Attach the Seat (#79) to the Horizontal Seat Bar (#80) using a total of three Washers (#81) and three Nylon Nuts (#82).

Remove the Knob Bolt (#57) that is pre-assembled on the Main Frame (#101) and set it aside for now, as it will be used later in this step.

Insert the Horizontal Seat Bar (#80) into the Seat Post (#83). Insert a Knob Bolt (#17) through a Washer (#84), followed by the Seat Post (#83) and Horizontal Seat Bar (#80), secure them together by tightening the Knob Bolt (#17) up through the bottom of the Horizontal Seat Bar (#80).

Insert the Seat Post (#83) a minimum of 4 inches into the Main Frame (#101) to engage the lowest hole and secure by screwing in the Knob Bolt (#57). Please ensure that the hole on the Seat Post (#83) is facing the same side as the Knob Bolt (#57) so it can be aligned and fully engage through the lowest corresponding hole on the Main Frame (#101).

# Assembly STEP 6

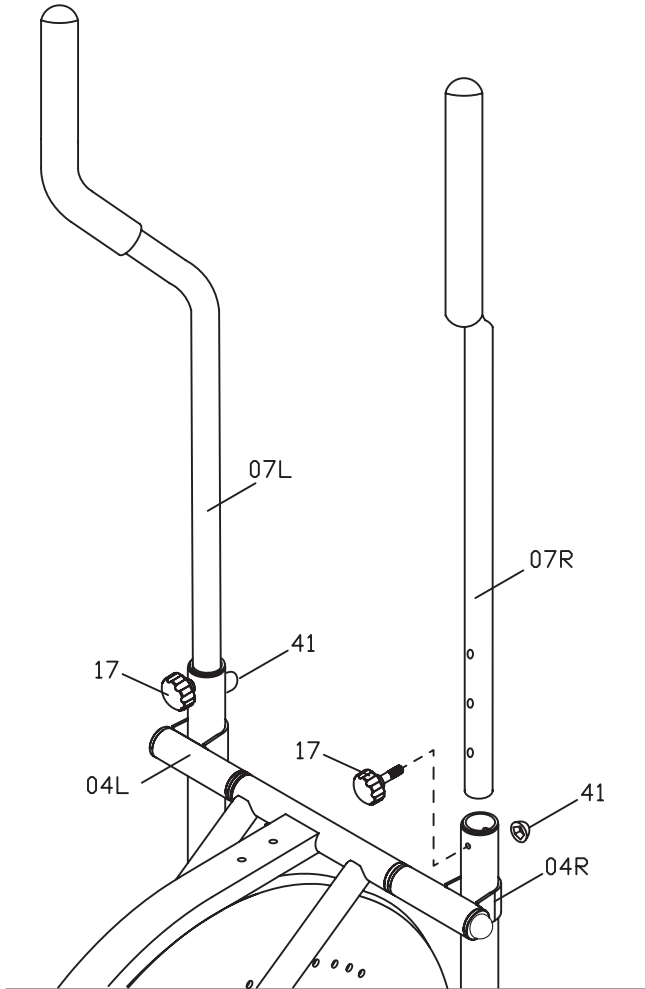

## Hardware Required

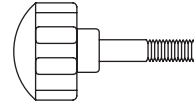

#17  
Knob Bolt  
(M8x36mm)  
[2 pieces]



#41  
Bolt Cap (S13)  
[2 pieces]

Insert the Left Handlebar (**#07L**) into the Left Coupler Bar (**#04L**) to a height setting that is comfortable to the user. You can always re-adjust the height setting after complete assembly for a better fit. Secure together using one Knob Bolt (**#17**) as shown below.

Attach one Bolt Cap (**#41**) over the end of the Knob Bolt (**#17**) as illustrated.

Making sure the settings for both Handlebars is the same, repeat this process on the other side using Right Handlebar (**#07R**), Right Coupler Bar (**#04R**), one Knob Bolt (**#17**), and one Bolt Cap (**#41**).

If you encounter too much friction, try using WD40 or Vaseline as a lubricant.

# Assembly STEP 7

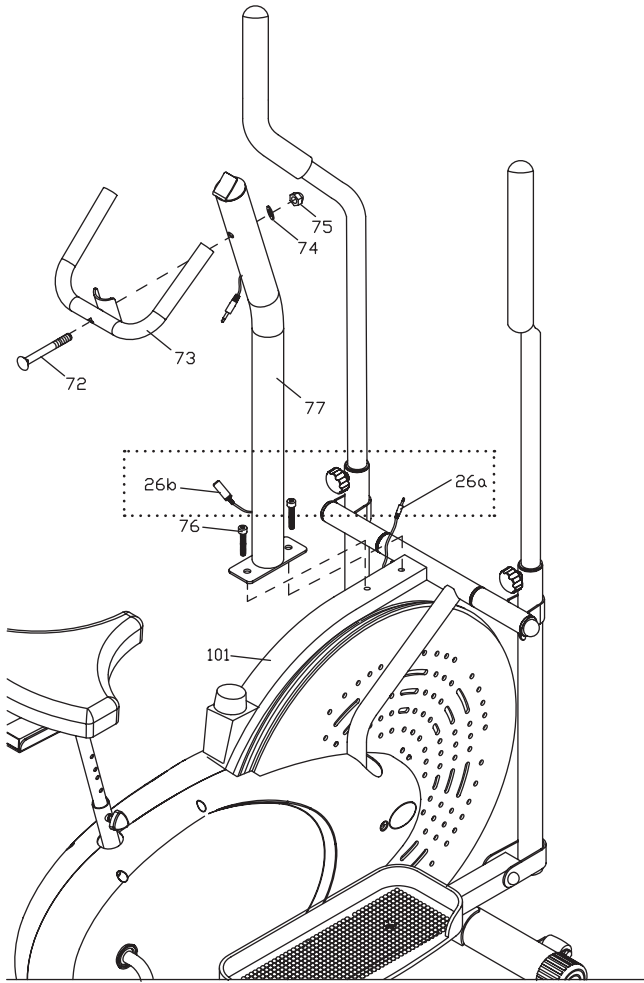

## Hardware Required

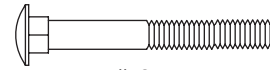

#72  
Carriage Bolt (M8x73mm)  
[1 piece]

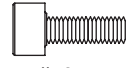

#76  
Bolt (M8x30 mm)  
Pre-assembled  
[2 pieces]



#74  
Arc Washer  
(Ø8.2x2xØ20xR28)  
[1 piece]



#75  
Cap Nut (M8)  
[1 piece]

Remove the Bolts (#76) that are pre-assembled on the Main Frame (#101) and set them aside as they will be used later in this step.

Making sure not to pinch any wires, secure the Center Post (#77) to the Main Frame (#101) using two Bolts (#76) as illustrated.

Connect the Sensor Wire (#26b) to the Sensor Wire (#26a).

Attach the Center Handle Bar (#73) to the Center Post (#77). Insert one Carriage Bolt (#72) through Center Handle Bar (#73) followed by the Center Post (#77). Secure them together using one Arc Washer (#74) and one Cap Nut (#75).

## Assembly STEP 8

Connect the pin on the tip of the Sensor Wire (#26b) to the corresponding socket of the wire end on the Electronic Monitor (#50) as shown in diagram below.

Being careful not to pinch any wires, attach the Electronic Monitor (#50) by sliding it in place onto the tip of the Center Post (#77).

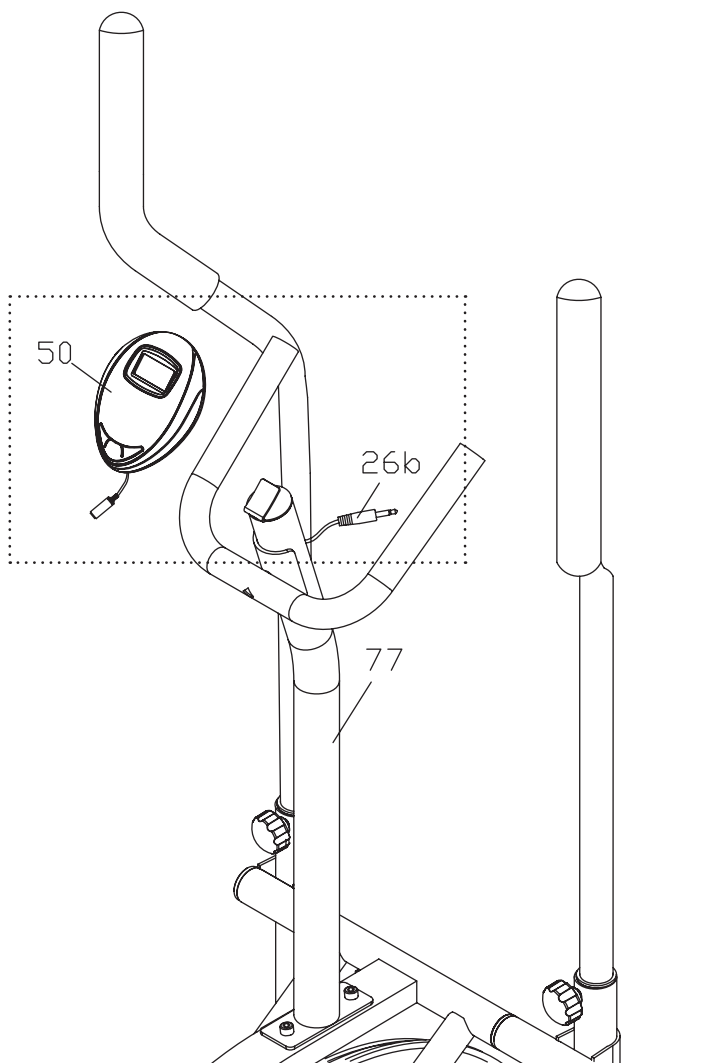

### THE ASSEMBLY PROCESS IS NOW COMPLETE.

However, for your own safety, please make sure to read this entire Owner's Manual which includes safety instructions and warnings, as well as any safety/warning labels affixed to the product before use. For your safety, please visually and functionally inspect and test the unit after assembly is complete.

# Tension Adjustment

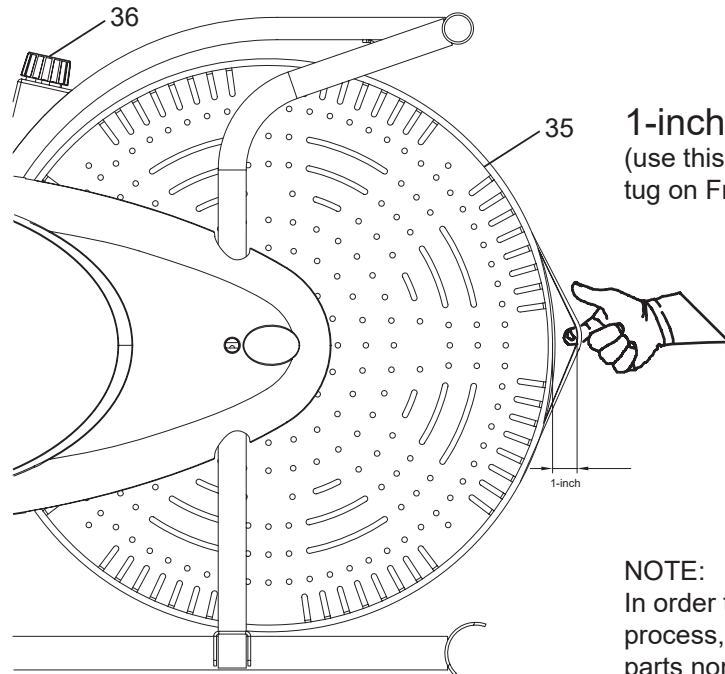

## 1-inch Distance

(use this measurement as a “test” when you gently tug on Friction Belt (#35) away from flywheel)

### NOTE:

In order to clearly show parts used in Tension Adjustment process, this drawing has been modified and does not show all parts nor full assembly.

### WARNING:

If the Friction Belt (#35) is tightened to an extremely tight/taut setting against the flywheel, you may risk damaging, over-wearing, over-stressing and/or breaking the Friction Belt (#35).

Please see below for more details to prevent damage and breakage.

### 1. FOR TENSION ADJUSTMENT:

Simply turn the Tension Adjustment Knob (#36).

- To increase tension (+ higher resistance and more difficult), turn clockwise.
- To decrease tension (- lower resistance and less difficult), turn counter-clockwise.

\*\*\*WARNING: Please turn the Tension Control (#36) gently. **DO NOT** use excess force to avoid damaging any parts of your unit.

### 2. FOR CALIBRATING TENSION ADJUSTMENT SYSTEM:

- Gently turn Tension Adjustment Knob (#36) counter-clockwise and keep turning until the knob can no longer turn (i.e. decrease the tension fully).
- Adjust the Friction Belt (#35) so that when you gently tug it out away from flywheel, there is a 1" distance of slack between the Friction Belt (#35) and the flywheel as shown in diagram.

\*\*\*WARNING: It is important you check for this minimum of 1-inch distance to avoid damaging, over-wearing, over-stressing and/or breaking the Friction Belt (#35).

### NOTE:

It is normal for the Friction Belt (#38) to periodically loosen due to regular use. Repeat the below process anytime you feel it may be necessary to recalibrate the tension adjustment system.

# Computer Operation

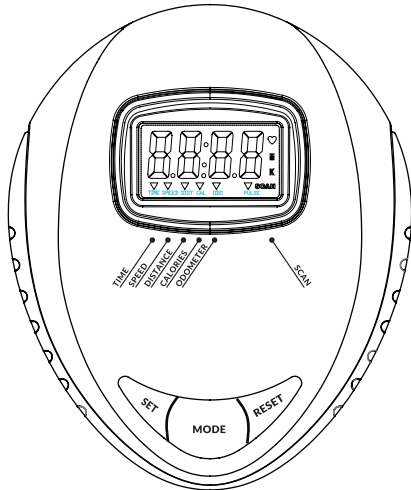

## Key Function

### MODE :

Press to select the display function of your choice.

### SET :

Press to set the display function

### RESET :

Press to reset all values

## Operation Procedures

### FUNCTION

- TIME** : Displays the total amount of time using the machine.
- SPEED** : Displays current speed.
- DISTANCE** : Displays the distance traveled.
- CALORIES** : Displays the amount of calories burned.
- ODOMETER** : Displays total accumulated distance. ODO will reset when MODE is pressed for 3 seconds or when batteries are changed.
- SCAN** : The monitor will then rotate displaying through the following functions: time,speed,distance, calories and odometer. Each function will display for 4 seconds.

### NOTE

1. If the display is faint or shows no figures ,please replace the batteries.
2. The monitor will automatically shut off if there is no signal received after 4 minutes .
3. The monitor will auto-power on when exercise and/or motion input is detected.
4. The monitor will automatically start calculating when you start to exercise and will stop calculating when you stop exercising for 4 seconds .

## Specifications

<b>FUNCTIONS</b>	AUTO SCAN	Every 4 seconds
	TIME	00:00-99:59 min
	ODOMETER	0-9999 mi.
	CALORIES	0.0-999.9 KCal
	DISTANCE	0.0-999.9 mi.
	BATTERY TYPE	2 pcs of AAA
	OPERATING TEMP	32°F - 104°F
	STORAGE TEMP	32°F - 160°F

### **\*IMPORTANT NOTE :**

Please remember that the functions in this computer are only meant to be tools to monitor your workout progress; they are not meant to provide medical information or be used for medical purposes. Please consult a physician before beginning any workout program.



# Part Listing

The following parts list describes all of the parts illustrated on the exploded diagram on the following page.

**PLEASE NOTE:** most of these parts are already pre-assembled on your unit.

#	Descriptoin	#	Descriptoin
101	Main Frame	42	Cap (S17)
02	Front Stabilizer	43	Arc Washer ( $\phi 10 \times 2.0 \times \phi 25 \times R28$ mm)
03	Rear Stabilizer	44	Hex Bolt (M10x45 mm)
04L	Left Coupler Bar	45	Nylon Nut (M10)
04R	Right Coupler Bar	46	Carriage Bolt (M10x57 mm)
05	Hex Bolt (M10x55 mm)	47	Nut (M10)
06L	Left Pedal Tube	48	Left Nylon Nut (B0.5x20 S19) (with BLACK inner nylon ring)
06R	Right Pedal Tube	49	Right Nylon Nut (B0.5x20 S19) (with WHITE inner nylon ring)
07L	Left Handle Bar	50	Electronic Monitor
07R	Right Handle Bar	51	Spring Washer (D12)
208L	Left Chain Cover	52	Nut (M6)
208R	Right Chain Cover	53	Gear Shaft ( $\phi 30.5 \times 77$ mm)
09	Fan Wheel ( $\phi 503 \times 55$ mm)	55	Chain Wheel (1/4"x $\phi 165 \times 2.6$ )
10	Spring ( $\phi 1.8 \times 32 \times \phi 10$ mm)	56	Washer ( $\phi 10.2 \times \phi 25 \times 2$ mm)
11	Pedal	57	Knob Bolt (M12x24 mm)
12	Handlebar Axle ( $\phi 16 \times 410$ mm)	58	Round Inner Plug ( $\phi 32 \times 1.5$ mm)
13	Round End Cap ( $\phi 50$ mm)	59	Hex Bolt (M6x48 mm)
14	Foam Grip ( $\phi 23 \times 5 \times 300$ mm)	60	Nylon Nut (M6)
15	Round Inner Plug ( $\phi 25 \times 2$ mm)	61	Nut (M10x1.0)
16	Handlebar Sleeve ( $\phi 28.5 \times \phi 25.4 \times 84$ mm)	162	Right Pedal Hinge Bolt
17	Knob Bolt (M8x36 mm)	163	Left Pedal Hinge Bolt
18	Front Rollers ( $\phi 23 \times 6.5 \times 32$ mm)	65	U Bracket
19	Bushing ( $\phi 24 \times 12 \times \phi 16.1$ mm)	66A	Pedal Connection Joint
20	Bushing ( $\phi 14 \times 10 \times \phi 10.1$ mm)	67	Rectangular Inner Plug (25x50 mm)
21	Bushing ( $\phi 18 \times 14 \times \phi 10.1$ mm)	68	Tool 1 (2-S17,S19)
22A	Fan Wheel Axle (M10x150 mm)	69	Tool 2 (S8)
23	Nut (M10x1xB5)	70	Tool 3 (S13-14-15)
24	Adjuster Bolt (M6x36 mm)	71	Washer ( $\phi 10.2 \times \phi 20 \times 2$ mm)
25	Nut (M10x1xB10x $\phi 20$ S15)	72	Carriage Bolt (M8x73 mm)
26	Sensor	73	Center Handle Bar
27	Crankshaft	74	Arc Washer ( $\phi 8.2 \times 2 \times \phi 20 \times R28$ mm)
28	Washer for Crankshaft	75	Nut (M8)
29	Washer for Crankshaft	76	Bolt (M8x30 mm)
30L	Left Crankshaft Bearing Collar	77	Center Post
30R	Right Crankshaft Bearing Collar	78	Foam Grip ( $\phi 23 \times 5 \times 125$ mm)
31	Crankshaft Bearing Set	79	Seat
32	Bearing Brace	80	Horizontal Seat Bar
33	Left Nut for Crankshaft	81	Washer ( $\phi 8.2 \times 1.2 \times \phi 17$ mm)
34	Chain (1/4"x204 Links)	82	Nylon Nut (M8)
35	Friction Belt (1150L mm)	83	Seat Post
36	Tension Adjustment Knob	84	Washer ( $\phi 10.5 \times 2 \times \phi 20$ mm)
37	Square Inner Plug ( $\square 30$ mm)	85	Tool 4 (S6)
38	Screw (ST4.8x20 mm)	86	Wavy Washer (16.2x $\phi 21 \times 17 \times 0.3$ t mm)
39	Screw (ST4.8x40 mm)	87	Wavy Washer
40	Screw (ST4.8x16 mm)		
41	Cap (S13)		

# Exploded View

The following diagram is provided to help you familiarize yourself with the parts and hardware that will be used during the assembly process.

**PLEASE NOTE** : Not all of the parts and hardware you see here will be used while you are assembling the machine because some of these items are already pre-installed. Please use this page only as a reference guide for parts and hardware.

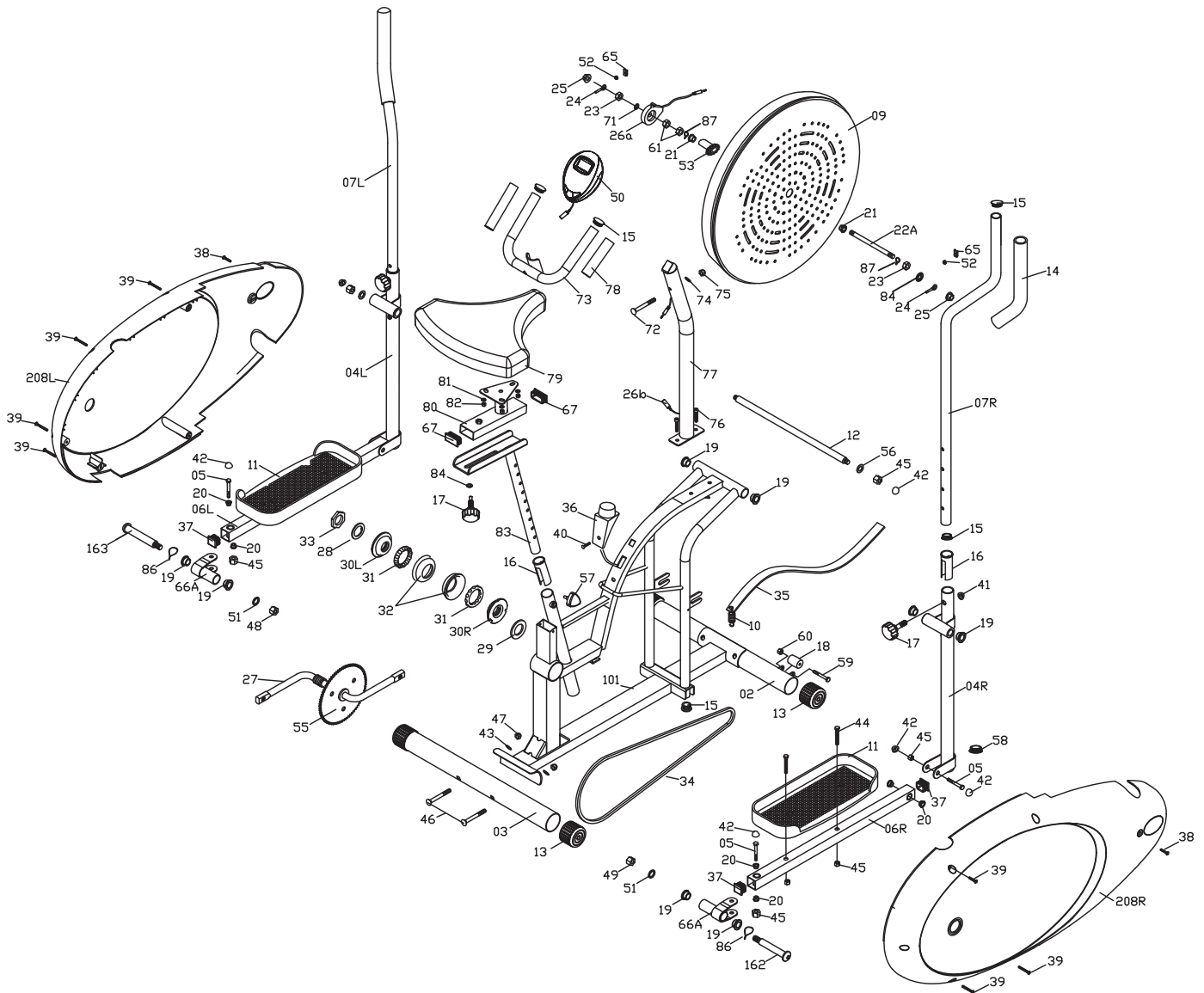

# Safety and Maintenance

## Safety & Warning

- Make sure all nuts, bolts, and screws are tightened prior to use.
- Be sure that all adjustment locking devices and safety devices are properly engaged prior to use!
- Never over-tighten the above-mentioned devices and parts to avoid damage to the unit.
- Check for loose parts and components and make proper adjustments prior to use.
- Check to see if there are any tears or bends in the welding or metal prior to use. If tears or bends are found, DO NOT use the unit and contact our CUSTOMER SUPPORT.
- Extreme care must be taken to not allow your feet, fingers, hair, clothing, and/or any loose items to be snagged into any portion of the bike when the unit is in motion. Failure to follow these instructions could result in serious injury, including the loss of fingers.
- Always wait for the pedals and other moving parts (which can gain great momentum during riding) to come to a complete stop before dismounting the unit to avoid serious injury.

## How To (Emergency) Stop

**NOTE :** Always wait for the pedals and/or any other moving parts (which can gain great momentum during riding) to come to a complete stop before dismounting the unit to avoid serious injury.

- To reduce speed on the bike, you may use the combinations of your feet on the Left/Right Pedals (#11) and your hands on the Left/Right Handlebars (#07L/#07R) to gently and safely apply counter-momentum.
- Wait for the pedals to come to a complete stop.
- Now you may safely dismount the unit

## How To Move/Transport The Bike For

### NOTE :

To safely move, transport, and/or store the unit, please seek the help of capable assistants (minimum of 2 people). The unit has integrated Front Rollers (#18) purposely intended to help ease this process.

- Position one person on each side at the front of the bike toward the handle Bar (one person on the left, and one on the right).
- Have each person use both hands to grip the corresponding Foam Grip for Handle Bar (#07). (These are the safest areas to avoid injury during this process.)
- Have both people simultaneously lift the rear end of the unit, leaving the weight and pressure into the front of the unit and onto the Front Rollers (#18) to move/transport the unit to the desired area.

## Maintenance & Care

- Please review all safety instructions and warnings in this entire Owner's Manual, as well as any safety/warning labels affixed to the product before use.
- Do not use solvent cleaners. If you are in any doubt, do not use your cleansing product; contact CUSTOMER SUPPORT.
- The specific parts on your unit which may see possible signs of wear after prolonged use are listed as follows (please check these parts before each use):  
Tension Adjustment Knob (#36); Pedals (#11); Left/Right Handlebars (#07L/#07R).
- For any replacement warning labels, please contact our CUSTOMER SUPPORT at

**1 (888) 266-6789** or **1 (909) 598-9876**, or mail in a written request to:

Body Flex Sports Inc.  
21717 Ferrero Parkway  
Walnut, CA 91789

More detailed information about how to reach our CUSTOMER SUPPORT may be found on Page 2 of the Owner's Manual under the "CUSTOMER SUPPORT" section.

# Troubleshooting

(AFTER COMPLETE ASSEMBLY)

Troubleshoot Area	Solution
<b>Calories/Distance/ Time (Etc.)</b>	<p>If the computer is <b><u>not displaying the CALORIES/DISTANCE/TIME/(ETC.) functions</u></b> (or you are getting inaccurate readings), please adjust the following:</p> <ol style="list-style-type: none"><li>1. Check to ensure all computer sensor wires are properly connected and are not damaged.</li><li>2. You may need to refer to installation/assembly directions for the sensor wires in this manual.</li></ol>
<b>Computer Display</b>	<p>If the <b><u>computer display is blank &amp; not displaying any data</u></b> (or does not appear to power on), please adjust the following:</p> <ol style="list-style-type: none"><li>1. Check to ensure all sensor wires are all properly connected and are not damaged.</li><li>2. Check to ensure the AC Adapter* or Batteries* are properly plugged in or fully charged.</li><li>3. Check your product manual to determine if your model uses either AC Adapter or batteries to power your unit.</li></ol>

# Warm-Up Instructions

Before use, you must read and understand all instructions & warnings stated in this Owner's Manual as well as posted on the equipment. Before beginning any exercise program including the following flexibility exercises, please consult with your physician.

The following flexibility exercises are provided to you as a means to prevent injury while you are exercising. A proper warm-up routine decreases the chance of injuring your muscles while you are exercising. Please take the time to do these flexibility exercises before and after each time you exercise.



## Groin Stretch

1. Sit with your knees flexed and soles of feet together.
2. Hold your ankles and bend at your hips (keep your back straight) as you press your knees toward the floor with your elbows.

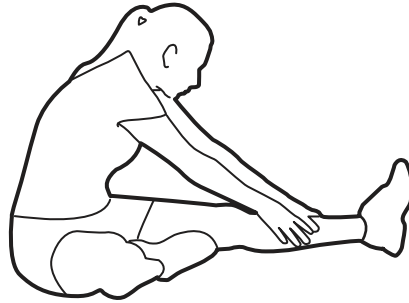

## Hamstring Stretch

1. Sit with your left leg extended and bend your right leg at the knee as you place the sole of your right foot against the inner thigh of your extended leg.
2. Flex the foot of your extended leg (toes pointed toward ceiling) and gently bend forward from your hips; keep your back straight.
3. Reach your hands on your extended leg as far as possible and then switch legs and repeat.

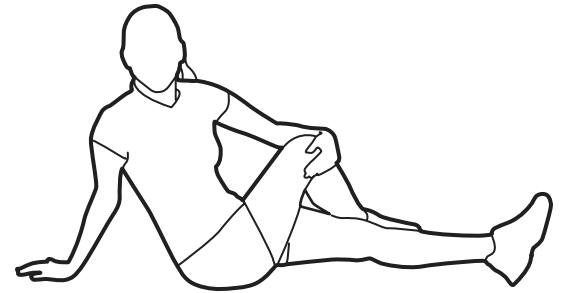

## Trunk Twister

1. Sit with your leg extended and bend your right knee as you cross your right leg over your left leg. Your right foot of your extended leg foot should be flat on the floor alongside your left knee.
2. Place your left arm on the outside of your right leg and pull against that leg while twisting your trunk as far as possible to the right. Place your right hand on the floor behind your buttocks. Reverse leg positions and repeat.

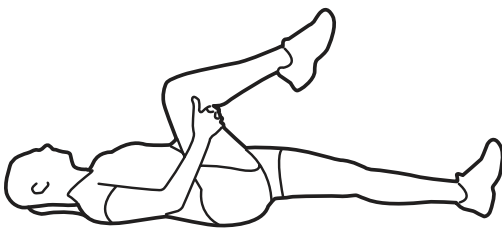

## Groin Stretch

1. Lie on your back and raise your right leg as you clasp both hands under the back of the knee. Keep your left leg straight.
2. Gently pull your right leg toward your trunk without raising your upper body. Switch leg positions and repeat.

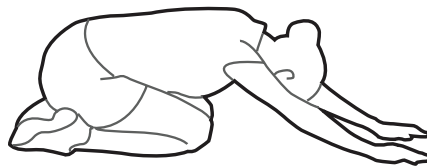

## Trunk Flexion, Prone

1. Assume the depicted position on your hands and knees. Stretch your hands out in front of you and then slowly start to pull them back in toward your body as you tuck your chin and arch your back upward.
2. Return to the starting position slowly.

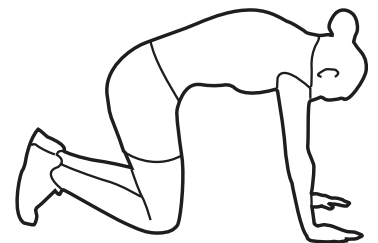

# Warm-Up Instructions

---



## Shoulder Stretch

---

1. Bring your right hand over your right shoulder to the upper back and bring your left hand under your left shoulder to the upper back.
2. Try to reach your fingertips. If you are not able to reach your fingertips, use a towel as an extension of your hands and gently pull one hand toward the other.  
Reverse arm positions and

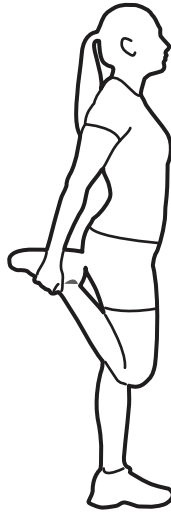

## Quadriceps Stretch

---

1. Stand on your left leg and hold onto a support with your left hand.
2. Flex your right leg behind you, grasp your ankle or foot with your right hand and pull your foot toward your buttocks. Keep your back straight and right knee pointed down.  
Repeat on the other leg.

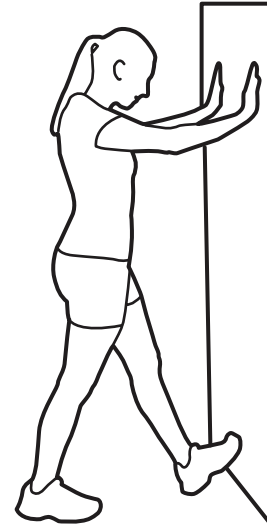

## Calf Twister

---

1. Place both hands against a wall to aid your balance. Press the ball of your left foot against the wall and keep the heel of the same foot rested on the floor (make sure your left knee is bent).
2. Slowly start to straighten your left knee and you will feel the muscles in your left calf stretch. Switch leg positions and repeat.

This page is left blank intentionally

**THANK YOU FOR YOUR PURCHASE**  
**MODEL NO.: BRD2835 / BRD2066**

Please fill in the information below and keep this manual along with your sales receipt as proof of purchase.

Serial Number :

---

Date of Purchase :

---

Retailer :

---

Body Flex Sports Inc.  
21717 Ferrero Parkway  
Walnut, CA 91789

Phone: 1 (888) 266-6789  
Fax : 1 (909) 598-6707  
Email : [info@bodyflexsports.com](mailto:info@bodyflexsports.com)