

# body power®

## PARALLETES SET Model No.: PL1000

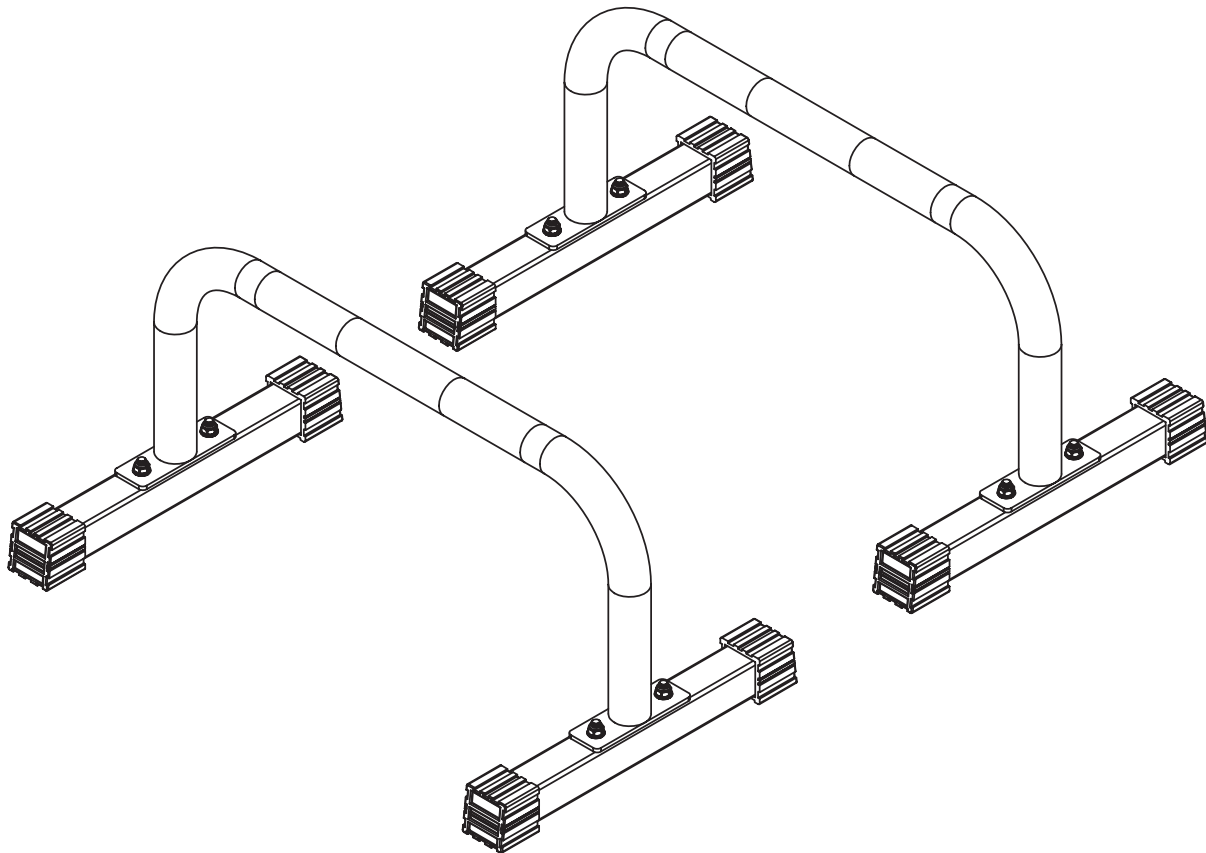

This product is intended for indoor, home use only and is not to be used in a commercial setting.

**CAUTION**

Maximum Weight Limit is 380 lbs.

**OWNER'S MANUAL**

**PLEASE KEEP THESE INSTRUCTIONS FOR FUTURE USE & REFERENCE.  
DO NOT DISCARD.**

**WARNING: SERIOUS INJURIES AND EVEN DEATH CAN OCCUR IF THE PROPER SAFETY PRECAUTIONS  
ARE NOT FOLLOWED.**

The diagram below highlights and reviews many of the important Safety and Warning labels also found on the unit. Please ensure any user of the unit familiarizes themselves with these Safety and Warning guidelines before use.

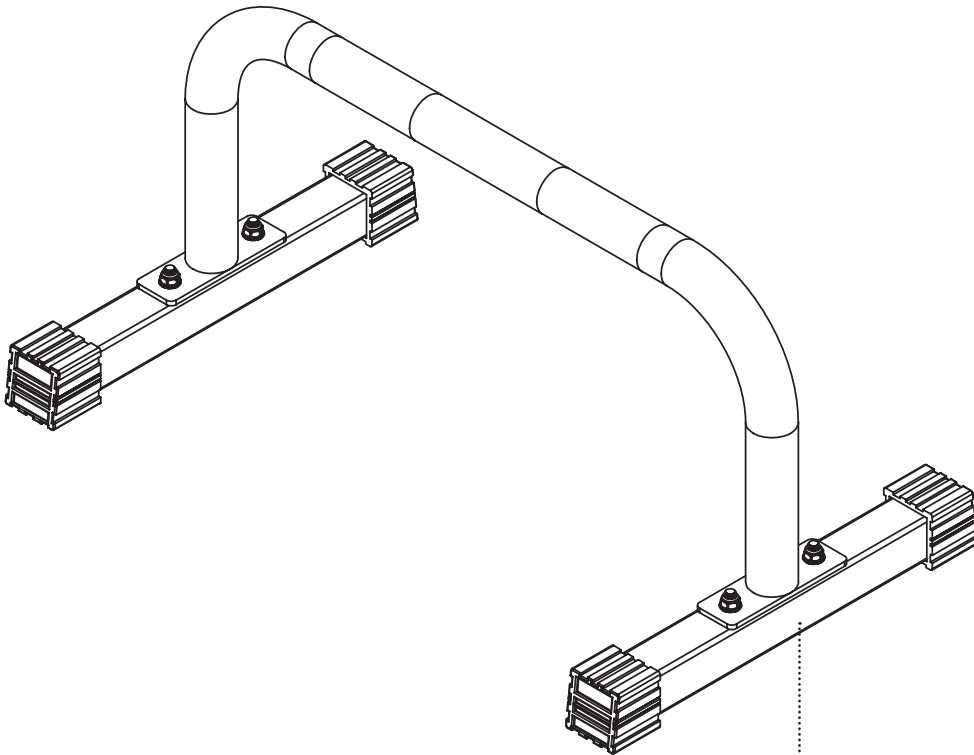

**! WARNING !**  
**DO NOT MISUSE THIS EQUIPMENT**  
Read and understand all instructions & warnings stated in the Owner's Manual before exercising. The possibility of serious injuries or death, or both (if applicable) if caution is not used. Do not allow children, minors or pets to play on or around this equipment. Before starting any exercise program, consult your physician. The equipment is not to be used in a commercial setting. This product is intended for indoor, home-use only.

# General Information

---

## Safety

Before you undertake any exercise program, please be sure to consult with your doctor.

Frequent strenuous exercise should be approved by your doctor and proper use of your product is essential.

Excessive or incorrect training may result to health injuries.

Please read this manual carefully before commencing the assembly of your product or starting to exercise.

- Please keep all children away from this item when in use. Do not allow children to climb or play on this item when it is not in use.
- Supervise teenagers while they use this unit.
- For your own safety, always ensure that there is at least 3 feet of free space in all directions around your product while you are exercising.
- Regularly check to see that all nuts, bolts and fittings are securely tightened. Periodically check all moving parts for obvious signs of wear or damage.
- Any adjustment devices that could interfere with the user's movement on this unit should not be left projecting.
- Clean only with a damp cloth, do not use solvent cleaners.  
If you are in any doubt, do not use your product; contact CUSTOMER SUPPORT.
- Before use, always ensure that your product is positioned on a solid, hard-flat surface.
- Do not place on carpet. If necessary, use a rubber mat underneath to reduce the possibility of slipping.
- Always wear appropriate clothing and footwear such as training shoes when exercising. Do not wear loose clothing that could become caught in moving parts during exercise.
- Do not use this unit if it is not functioning properly or if it is not fully assembled.
- Do not use this unit for commercial purposes. This unit is for home use only.
- Before use, you must read and understand all instructions & warnings stated in this Owner's Manual as well as posted on the equipment.
- It is the facility owner's responsibility to properly instruct users on the proper operation of the equipment and to warn them of the potential hazards.
- If at any time during exercise you feel faint, dizzy or experience pain, stop and consult your physician.

## Weight Limit

Your product has a maximum weight limit of:  
380 pounds for user weight.

## Storage and Use

Your product is intended for use in clean dry conditions. You should avoid storage in excessively cold or damp places as this may lead to corrosion and other related problems.

## Warranty

Body Power warrants your product for a period of 1 year for the frame and 90 days on all parts if the item is used for the intended purpose, properly maintained and not used commercially.

Any alterations or incorrect assembly of the product will void this warranty.

Proof of purchase must be presented for any warranty validation (no exceptions). This warranty applies to the original purchaser only and is not transferable.

This warranty does not cover abuse or defects caused during use, storage or assembly. During the warranty period, Body Power reserves the right to:

1. provide replacement parts to the purchaser in an effort to repair the item.
2. repair the product returned to our warehouse (at the purchaser's cost).
3. replace the product if neither of the two previously mentioned actions effect repair. This warranty does not cover normal wear and tear on upholstery.

## Questions

If you have any questions concerning the assembly of your item or if any parts are missing, please **CONTACT OUR CUSTOMER SUPPORT TEAM DIRECTLY FOR ACCURATE AND EXPEDITED ASSISTANCE; DO NOT RETURN** the item to the store or contact the retailer which may likely cause delays in support to you.

Our dedicated customer service staff can help you with any questions you may have regarding the assembly of this unit and can also mail you replacement parts.

## Customer Support

Customer Support is open 9:00 a.m. to 5:00 p.m. (Pacific Time) Monday through Friday.

Please contact us by any of the following methods :

**Body Power**  
21717 Ferrero Parkway  
Walnut, CA 91789

Telephone: 1 (888) 266 - 6789  
Fax: 1 (909) 598 - 6707  
Email: [info@bodyflexsports.com](mailto:info@bodyflexsports.com)

# Before Assembly

## WARNING

1. Take a few minutes to familiarize yourself with the parts and hardware included with your product.
2. Assembly may require two people.
3. Check the frame for any damage and check any wiring (if present) for rips or tears. If you detect damage, rips, or tears, please contact our Customer Support Team before beginning any assembly.
4. Make sure all the hardware needed is included.
5. It is very important to follow the assembly instructions correctly and to make sure all parts are attached correctly and firmly tightened when the assembly process is complete.
6. Parts that are not tightened correctly will seem loose and can cause irritating noises and will cause damage to the equipment.

**PLEASE NOTE** : Some of the parts and hardwares listed on the parts list may already pre-assembled or installed on the unit.

## Nylon Lock Safety Nuts

1. It is only necessary to tighten the bolts and nuts to “finger tight” during the assembly process. This will make it easier to complete certain steps by allowing more tolerance for all the parts to fit properly.
2. Do not tighten all the nuts onto the bolts securely until after you have completed assembly of your product.
3. Use wrenches, pliers, or ratchet and sockets to tighten the bolts and nuts.
4. The Nylon Nut should thread onto the Hex Bolt until the end of the Hex Bolt has passed through the Nylon insert inside the Nut. Please follow this guideline everytime you see this *Nylon Nut icon* throughout the assembly steps.

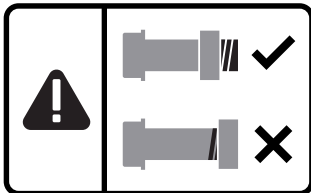

# Part Listing and Exploded View

The following parts list describes all of the parts illustrated on the exploded diagram on the following page.

**PLEASE NOTE:** Not all of the parts and hardware you see here will be used while you are assembling the unit because some of these items are already pre-installed. Please use this page only as a reference guide for parts and hardware.

No.	Description	Q'TY
01	Handrail	2
02	Bottom Base	4
03	End Cap	8
04	Cup Head Square Neck Bolt M8*55	8
05	Washer $\Phi 8$	8
06	Nylon Lock Nut M8	8
07	Screw Driver	1

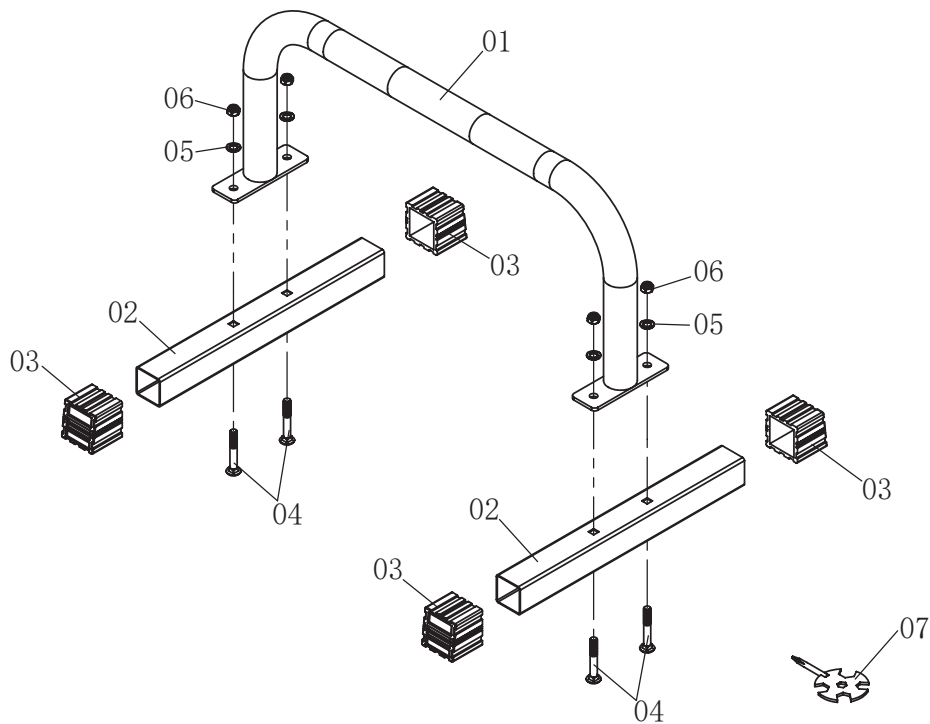

# Hardware and Tool List

---

## Bolts

---

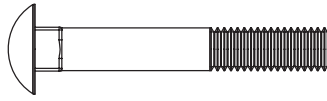

#04 Carriage Bolt (M8X55)  
[8 Pieces]

## Washers

---



#05 Washer (M8)  
[8 Pieces]

## Nuts

---



#06 Nylon Nut (M8)  
[8 Pieces]

## Others

---

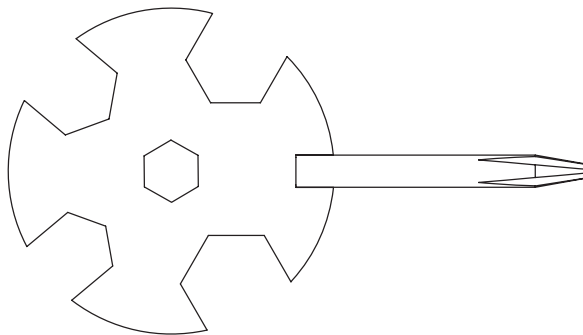

#07 Tool  
[1 Piece]

# Assembly STEP 1

**NOTE:**

*To avoid misalignment due to over-tightening, please do not use a wrench at this time. Hand-tightening for now will help ensure easy assembly.*

*Wrench-tightening should be performed after all parts are assembled to ensure all nuts, bolts, and parts are tightly secured before use.*

Attach both Bottom Bases (#02) to the Handrail (#01) by inserting four Carriage Bolts (#04) up through the Bottom Bases (#02) and secure with four Washers (#05) and four Nylon Nuts (#06).

## Hardware Required

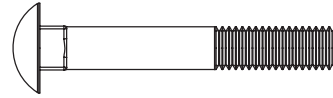

#04 Carriage Bolt (M8X55)  
[8 Pieces]



#05 Washer (M8)  
[8 Pieces]



#06 Nylon Nut (M8)  
[8 Pieces]

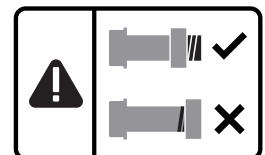
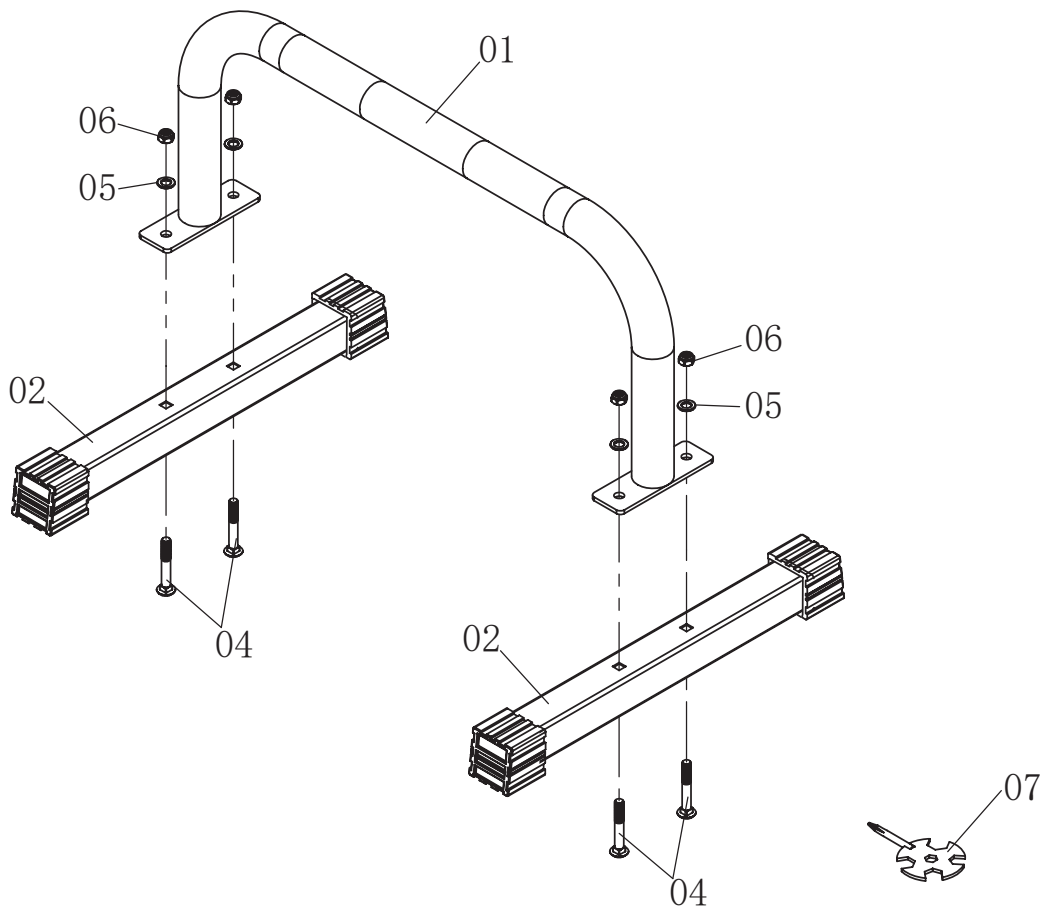

# Safety and Maintenance

---

## Safety & Warning

- Make sure all nuts, bolts, and screws are tightened prior to use.
- Be sure that all adjustment locking devices and safety devices are properly engaged prior to use!
- Never over-tighten the above-mentioned devices and parts to avoid damage to the unit.
- Check for loose parts and components and make proper adjustments prior to use.
- Check to see if there are any tears or bends in the welding or metal prior to use. If tears or bends are found, DO NOT use the unit and contact our CUSTOMER SUPPORT.
- Extreme care must be taken to not allow your feet, fingers, hair, clothing, and/or any loose items to be snagged into any portion of the unit when the unit is in use. Failure to follow these instructions could result in serious injury.

## Maintenance & Care

- Please review all safety instructions and warnings in this entire Owner's Manual, as well as any safety/warning labels affixed to the product before use.
- To avoid rust or corrosion to the metal parts caused by moisture and sweat, we advise wiping and drying the unit with a dry absorbent towel after each workout session.
- Do not use solvent cleaners. If you are in any doubt, do not use your cleansing product; contact CUSTOMER SUPPORT.
- For any replacement warning labels, please contact our CUSTOMER SUPPORT at :

**1 (888) 266-6789** or **1 (909) 598-9876**, or mail in a written request to:

**Body Power**  
21717 Ferrero Parkway  
Walnut, CA 91789

More detailed information about how to reach our CUSTOMER SUPPORT may be found on the General Information page of this manual.



# Warm-Up Instructions

Before use, you must read and understand all instructions & warnings stated in this Owner's Manual as well as posted on the equipment. Before beginning any exercise program including the following flexibility exercises, please consult with your physician.

The following flexibility exercises are provided to you as a means to prevent injury while you are exercising. A proper warm-up routine decreases the chance of injuring your muscles while you are exercising. Please take the time to do these flexibility exercises before and after each time you exercise.



## Groin Stretch

1. Sit with your knees flexed and soles of feet together.
2. Hold your ankles and bend at your hips (keep your back straight) as you press your knees toward the floor with your elbows.

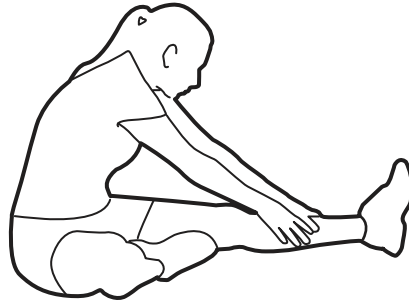

## Hamstring Stretch

1. Sit with your left leg extended and bend your right leg at the knee as you place the sole of your right foot against the inner thigh of your extended leg.
2. Flex the foot of your extended leg (toes pointed toward ceiling) and gently bend forward from your hips; keep your back straight.
3. Reach your hands on your extended leg as far as possible and then switch legs and repeat.



## Trunk Twister

1. Sit with your leg extended and bend your right knee as you cross your right leg over your left leg. Your right foot of your extended leg foot should be flat on the floor alongside your left knee.
2. Place your left arm on the outside of your right leg and pull against that leg while twisting your trunk as far as possible to the right. Place your right hand on the floor behind your buttocks. Reverse leg positions and repeat.

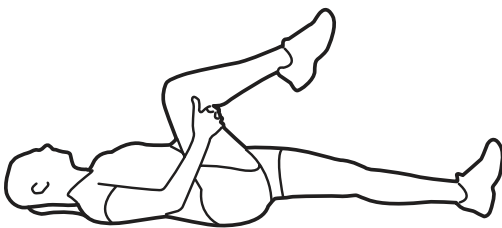

## Groin Stretch

1. Lie on your back and raise your right leg as you clasp both hands under the back of the knee. Keep your left leg straight.
2. Gently pull your right leg toward your trunk without raising your upper body. Switch leg positions and repeat.

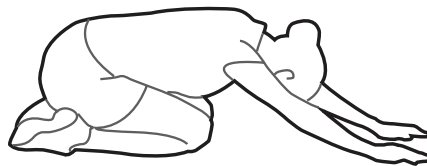

## Trunk Flexion, Prone

1. Assume the depicted position on your hands and knees. Stretch your hands out in front of you and then slowly start to pull them back in toward your body as you tuck your chin and arch your back upward.
2. Return to the starting position slowly.

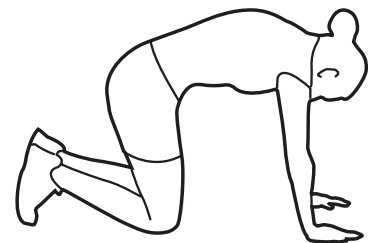

# Warm-Up Instructions

---



## Shoulder Stretch

---

1. Bring your right hand over your right shoulder to the upper back and bring your left hand under your left shoulder to the upper back.
2. Try to reach your fingertips. If you are not able to reach your fingertips, use a towel as an extension of your hands and gently pull one hand toward the other.  
Reverse arm positions and

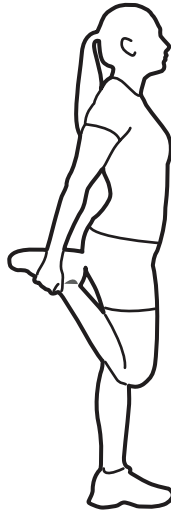

## Quadriceps Stretch

---

1. Stand on your left leg and hold onto a support with your left hand.
2. Flex your right leg behind you, grasp your ankle or foot with your right hand and pull your foot toward your buttocks. Keep your back straight and right knee pointed down.  
Repeat on the other leg.

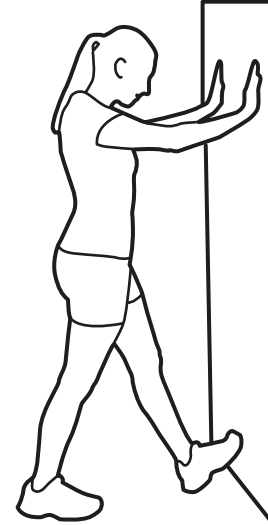

## Calf Twister

---

1. Place both hands against a wall to aid your balance. Press the ball of your left foot against the wall and keep the heel of the same foot rested on the floor (make sure your left knee is bent).
2. Slowly start to straighten your left knee and you will feel the muscles in your left calf stretch. Switch leg positions and repeat.

This page is left blank intentionally

**THANK YOU FOR YOUR PURCHASE**  
**MODEL NO.: PL1000**

Please fill in the information below and keep this manual along with your sales receipt as proof of purchase.

Serial Number :

---

Date of Purchase :

---

Retailer :

---

Body Power  
21717 Ferrero Parkway  
Walnut, CA 91789

Phone: 1 (888) 266-6789  
Fax : 1 (909) 598-6707  
Email : [info@bodyflexsports.com](mailto:info@bodyflexsports.com)